





A	—	B	
ABRASIVES:			
BANDS.....	102	BACK-UP PADS .....100, 102, 284	
CARTRIDGE ROLLS.....	103	BALL KEY WRENCHES .....376-377	
CUT-OFF WHEELS .....	98-99	BALL JOINT ASSEMBLIES .....	85
DRUMS.....	102	BALL PAINT MARKERS .....	172
FLAP DISCS.....	100	BALL VALVES .....	319, 340
FLAP WHEELS.....	102	BALLASTS .....	246
GRINDING WHEELS.....	97-100	BANDING .....	229
HAND PADS.....	103	BANDING CUTTERS .....	344
HAND STONES.....	99	BANDSAW BLADES .....	133-137
MOUNTED STONES.....	99	BANDSAW MACHINES .....	287
SANDING BELTS.....	101	BAR CLAMPS.....	393
SANDING DISCS.....	100-102	BARREL BOLTS .....	234
SANDING SHEETS, ROLLS.....	100-101	BARREL PUMPS .....	331
SURFACE CONDITIONING .....	103-104	BARRICADES, ROAD .....	215
ABSORBENTS .....	257	BATTERIES .....	240, 242-244
ACETONE .....	183	BATTERY CHARGERS .....	256
ACID BRUSHES .....	184	BATTERY CLEANER .....	197
ADHESIVE SPRAY.....	175	BATTERY PROTECTORS .....	196
ADHESIVE, WOOD .....	189	BATTERY TERMINALS .....	256
ADJUSTABLE WRENCHES.....	353, 372	BATTERY TESTER .....	256
AIR BRAKE ANTI-FREEZE.....	196	BATTERY TOOLS .....	381
AIR BRAKE TUBING.....	314, 327	BEAM CLAMPS .....	339
AIR FRESHENERS.....	179	BEARING PACKER.....	329
AIR HAMMER .....	296	BEARING SPLITTER .....	383
AIR MUFFLERS.....	325	BELTS:	
AIR TOOLS .....	294-296	SUPPORT .....	212
AIR TOOL OILS .....	193	V-BELTS.....	316
AIRLINE FILTERS & REGULATORS.....	313	WORK .....	204
AIRLINE FITTINGS.....	311-312	BELT DRESSING .....	174
ALLEN WRENCHES.....	375-377	BELT SANDER .....	292
ALLEN SOCKETS.....	354, 357-358, 362, 366, 369-370	BENCH GRINDER .....	287-288
ALLIGATOR CLIPS .....	165	BERNZOMATIC TORCHES .....	277
ALLTHREAD ROD.....	56, 78-79	BESSEY CLAMPS .....	393-394
ANCHORS, MASONRY.....	92-96	BINS, STORAGE .....	413-414
ANCHOR SHACKLES.....	226	BIT HOLDERS .....	350
ANGLES:		BITS, POWER .....	349
IRON/BRACES.....	236	BLADES:	
SLOTTED .....	235	BANDSAW .....	133-137
ANNULAR CUTTERS/PINS .....	113, 309	CIRCULAR SAW .....	141
ANTI-BACTERIAL HAND SOAP.....	198	DEBURRING .....	125
ANTI-FREEZE .....	196-197	HACKSAW .....	140
ANTI-FREEZE TESTERS.....	256	JIGSAW .....	140
ANTI-SEIZE .....	174, 191	PORTABLE BAND .....	137
ANTI-SPLATTER.....	175	POWER HACKSAW .....	140
APRONS.....	204-205, 211, 281	RECIPROCATING SAW .....	140
ARBORS:		UTILITY KNIFE .....	149
HOLESAW.....	139	BLASTER PRODUCTS .....	180, 193
SHAFT.....	88	BLEACH .....	181
TAPER.....	283	BLOW GUNS .....	310
WHEEL.....	98, 102-103, 276	BOLT CUTTERS .....	233
ASPHALT RAKES.....	406	BOLT EXTRACTORS .....	124
ASPHALT ROLLER .....	408	BOLTS:	
AUTOMATIC TRANSMISSION FLUID.....	197	A325 STRUCTURAL .....	14
AVIATION SNIPS.....	344	BRASS .....	53-54
AWLS.....	153	CARRIAGE, GRADE 2.....	13
AXES.....	384-385	CARRIAGE, GRADE 5 .....	15
		CARRIAGE, STAINLESS.....	47

<b>B</b>	<b>B</b>
<b>BOLTS (CONTINUED):</b>	<b>BULBS (CONTINUED):</b>
ELEVATOR .....15	ROUGH SERVICE .....246
FULL THREAD, GRADE 2, 5, 8.....3-4	SPOTLIGHT .....246
HANGER .....25	BUNGEE CORDS .....220
HEX FLANGE.....15	BURS, CARBIDE .....147-148
HEX HEAD, GRADE 2.....1-2	BUSHINGS-SHAFT .....87-88
HEX HEAD, GRADE 5 .....5-8	
HEX HEAD, GRADE 8.....9-12	<b>C</b>
HEX HEAD STAINLESS.....42-43	C-CLAMPS .....392
METRIC.....57-63	C-CLAMP PLIERS .....343, 374
METRIC, STAINLESS.....73-74	CABINETS, STORAGE .....414
NYLON, HEX HEAD.....56	CABLE, WIRE ROPE .....221
PLOW, GRADE 8.....15	CABLE CLAMPS .....222, 255
SQUARE HEAD .....15	CABLE CUTTERS .....221, 342
T-SLOT.....394	CABLE TIES, NYLON .....255
<b>BOOTS .....211</b>	CALCIUM CHLORIDE .....183
<b>BOW SAW .....407</b>	CALIPERS .....154, 158-159, 161
<b>BRAKE CLEANERS .....196</b>	CARBURETOR CLEANER .....196
<b>BRAKE FLUID .....196</b>	CARBIDE BURS .....147-148
<b>BRASS FITTINGS .....318-322, 324-327</b>	CARBIDE END MILLS .....129
<b>BRASS HAMMERS .....386</b>	CARBIDE DRILL BITS .....111, 114
<b>BRASS TAGS .....170</b>	CARPET CLEANER .....181
<b>BRAZING ROD .....280</b>	CARRIAGE BOLTS .....SEE "BOLTS"
<b>BROOM HANDLES .....272</b>	CARTON CUTTERS .....149
<b>BROOMS .....270-272</b>	CARTRIDGE ROLLS .....103
<b>BRUSH ARBOR ADAPTERS .....275</b>	CARTS, UTILITY .....259, 399
<b>BRUSHES:</b>	CASTERS .....399
ACID .....184, 273	CAULKING GUNS .....186
FENDER .....273	CAULKS & SEALANTS .....186
HAND WIRE .....184, 273	CEMENT TROWELS .....151
PAINT .....273-274	CENTER DRILL - INDEXABLE .....130
PARTS CLEANING .....273	CENTER HEAD .....160
SASH .....273	CHAIN & FITTINGS .....224-228, 231-232
SCRUB .....273	CHAIN BINDERS .....228
SNOW .....256	CHAIN (ROLLER) BREAKERS .....228
TOILET .....273	CHAIN CLAMP PLIERS .....343
TRUCK WASH .....273	CHAIN SNAPS .....231
TUBE .....276	CHAIN WRENCHES .....378
WHITEWASH .....274	CHALK .....168, 172
WIRE.....184, 273, 275-276	CHALK BOXES .....168
WIRE CUP .....275-276	CHALK LINE.....218
WIRE END .....275	CHANNELLOCK TOOLS .....341-342
WIRE SCRATCH .....184	CHEST HANDLES .....234
WIRE WHEEL .....275	CHECK VALVES .....340
<b>BUCKET HOOKS .....227</b>	CHIPPING HAMMER .....280
<b>BUCKETS .....261, 411</b>	CHIPPING HAMMER, AIR .....296
<b>BLUFF &amp; BLEND PRODUCTS .....103-104</b>	CHISEL HOLDER .....383, 389
<b>BUFFING ROLLS .....103</b>	<b>CHISELS:</b>
<b>BUFFING WHEEL .....99</b>	AIR.....296
<b>BULBS:</b>	ROTO-HAMMER .....114
AUTOMOTIVE .....246	CHISELS & SETS .....389-391
FLASHLIGHT .....240	CHOP SAW .....292
FLUORESCENT.....246-247	CIRCLE CUTTER .....153
HALOGEN .....245	CIRCUIT TESTER .....165
HIGH-PRESSURE SODIUM.....246	CIRCULAR SAW .....285
METAL HALIDE.....246	

C

C

CLAMPS:

BAR .....393  
 BESSEY.....393-394  
 "C" .....374, 392  
 CONDUIT .....339  
 HOLD DOWN .....394  
 HOSE .....314  
 PIPE FIXTURE .....392  
 SPRING .....392  
 TOGGLE .....394  
 TUBING .....255  
 WELDING .....280, 393

CLAMP ON LIGHTS .....247

CLEANERS:

DEGREASERS.....175-176, 180, 196  
 DRAIN .....183  
 FLOOR .....181  
 GENERAL PURPOSE .....179, 181, 182  
 PRESSURE WASHER .....180  
 PVC .....184  
 STAINLESS STEEL .....179, 182  
 TILE .....179, 182  
 TOILET BOWL .....179  
 WINDOW .....179

CLEANSER .....181

CLEAR ACRYLIC SPRAY .....175

CLEAVES .....226

CLEVIS PINS .....85

COAT HOOK .....235

COIL AIR HOSE .....310

COLLARS, SPLIT .....87

COLLETS, R8 .....130

COMBINED DRILLS & COUNTERSINKS .....125

CONCRETE ANCHORS .....92-95

CONDUIT CLAMPS .....339

CONES .....215, 260

CONSTRUCTION ADHESIVE .....188

CONSTRUCTION BARRELS .....215

CONTACT CEMENT .....190

CONTACT CLEANERS .....176, 192

CONTINUITY TESTER .....165

COOLANT HOSE & ACCESSORIES .....315

COOLANT UNITS .....310

COOLANTS - MACHINE .....194

COPPER TUBING .....323, 327

CORDLESS TOOLS .....290-291

CORNER BRACES .....234, 236

COTTER PINS .....47, 85

COUNTERBORE, CAP SCREW .....125

COUNTERSINKS .....125

COUPLING SHAFT .....87-88

CRACK DETECTOR .....176

CRAZY GLUE (CYANOACRYLATES) .....189

CRC LUBRICANT .....192

CREEPERS .....289

CRESCENT TYPE WRENCHES.....351-353  
 ECONOMY .....372

CROWBARS .....391

CROWFOOT COUPLERS .....312

CROWFOOT WRENCHES .....353

CUP DISPENSERS .....412

CUP HOOKS .....231

CUPS:

PAPER .....412

STYROFOAM .....262

CUT OFF WHEELS .....SEE "ABRASIVES"

CUTTING FLUID:

METAL .....194-195

CUTTING LUBE .....174, 191

D

DEBURRING TOOLS.....125

DEGREASERS .....175-176, 180, 196, 306

DENATURED ALCOHOL .....183

DESTACO TYPE CLAMPS .....394

DIAL INDICATORS & ACCESSORIES .....158

DIAL CALIPERS .....159

DIAMOND BLADES .....99

DIE GRINDERS .....284, 295

DIE SETTERS BAR .....391

DIE STOCK .....123

DIELECTRIC GREASE .....188, 192

DIES:

HEX .....121

PIPE .....379

ROUND .....121

DIESEL FUEL CONDITIONER .....196

DIGITAL CALIPERS .....161

DISINFECTANTS .....179, 181, 182

DISPOSABLE COVERALLS .....211

DOO-HATS .....281

DOOR PULLS .....235

DOWEL PINS .....40, 48, 66

DRAIN COCKS .....319

DRAIN CLEANERS .....183, 285, 380

DRAIN PANS .....411

DREMEL ENGRAVER .....171

DRILL ARBORS .....283

DRILL BIT EXTENSIONS .....115

DRILL BITS:

CARBIDE TIP .....111

COBALT .....110

EXTRA LENGTH .....109

JOBBER .....105

LEFT HAND .....110

MASONRY .....114

MECHANICS LENGTH .....110

**D**

DRILL BITS (CONTINUED):  
 REDUCED SHANK .....107  
 SETS .....113  
 SOLID CARBIDE .....111  
 STEP .....113  
 STUB LENGTH .....106  
 TAPER SHANK .....108  
 TITANIUM COATED .....110  
 TWIN DRILLS .....110  
 WOOD BORING .....115  
 DRILL CHUCKS & KEYS .....282-283, 308  
 DRILL DRIFTS .....113  
 DRILL GAUGES .....112,157  
 DRILL INDEXES .....112  
 DRILL PRESSES .....287  
 DRILL ROD .....80  
 DRILL SHARPENER .....112, 154  
 DRILL SLEEVES/SOCKETS .....113  
 DRILL STOP SET .....112, 155  
 DRILLS, AIR .....294  
 DRILLS, CORDLESS.....290-291  
 DRILLS, ELECTRIC .....282, 286  
 DROP CLOTHS .....268  
 DRUM:  
 CRADLES .....398  
 DEHEADERS .....331  
 DOLLIES .....398  
 FAUCETS .....331  
 LIFTERS .....226  
 PLUG WRENCH .....331  
 PUMPS .....331  
 DRY GRAPHITE .....174  
 DRY LUBE MOLY .....174  
 DRYWALL SCREWS .....SEE "SCREWS"  
 DUCK BUTTER .....185  
 DUCT TAPE .....258  
 DUPLEX SLEEVES .....221  
 DUST MASKS .....209  
 DUST MOP.....270  
 DUST PANS .....259, 270  
 DYKEM PRODUCTS .....173

**E**

E-CLIPS .....83  
 EAR PLUGS .....210  
 EASY-OUTS.....124  
 EDGE FINDER .....153  
 ELECTRODE HOLDER .....280  
 END MILLS .....126-130  
 ENGINE DEGREASER .....175  
 ENGINE PULLER .....223  
 ENGRAVER .....171  
 EPOXIES .....189-190  
 EXTENSION CORDS & ACCESSORIES .....248-250

**E**

EXTRACTORS.....124  
 EYE BOLTS .....230-232  
 E-ZOUTS.....124

**F**

FACE SHIELDS .....205  
 FANS.....400-401  
 FAUCET, HOSE .....339  
 FEELER GAUGE .....156-157  
 FENCE, ORANGE SAFETY .....215  
 FILES & ACCESSORIES .....144-146  
 FILES - THREAD REPAIR .....122  
 FILTERS, AIRLINE.....313  
 FIRE EXTINGUISHERS .....217  
 FIRST AID KITS .....206  
 FLANGE NUT - TABLE CLAMPING .....394  
 FLAGS & PENNANTS .....212, 216  
 FLAP DISCS .....SEE "ABRASIVES"  
 FLARES .....214  
 FLARING TOOLS .....380  
 FLASHERS, BARRICADE .....216  
 FLASHLIGHTS .....240-244  
 FLAT GROUND STOCK .....80  
 FLAT WASHERS .....SEE "WASHERS"  
 FLEXANGLE .....235  
 FLINTS .....277  
 FLOOR CLEANERS .....181  
 FLOOR COATINGS .....181  
 FLOOR DRY .....257  
 FLOOR PATCH COMPOUNDS .....190  
 FLOOR SCRAPER .....405  
 FLUX .....184  
 FLUX CHIPPER .....296  
 FOAM SEALANT .....186  
 FOLD-UP KEY SETS .....375, 377  
 FOOT GUARDS .....211  
 FORM-A-GASKET .....188  
 FORM STRIPPING BAR .....391  
 FUEL STABILIZER .....197  
 FUNNELS .....411  
 FURNACE FILTERS .....402  
 FURNITURE POLISH .....181  
 FUSES, AUTOMOTIVE .....254

**G**

GALVANIZING SPRAY .....175  
 GARDEN HOSE.....264  
 GARDEN HOSE FITTINGS .....321  
 GAS CANS .....410  
 GAS LEAK DETECTOR.....185  
 GAS LINE ANTIFREEZE .....196  
 GAS VALVES .....340  
 GASKET MATERIAL .....187-188  
 GASKET REMOVER .....175

**G**

GASKET SCRAPER .....382  
 GASKET SEALANTS .....187-188  
 GATE VALVES .....340  
 GAUGES:  
     DRILL .....112, 157  
     PRESSURE .....317  
     RADIUS .....157  
     SHEET METAL .....157  
     TELESCOPING .....161  
     THICKNESS .....156-158  
     THREAD .....157  
     TIRE .....310  
     WIRE .....157  
 GEAR LUBE .....191  
 GEAR PULLERS .....383  
 GFCI CORDS .....249  
 GLOVES .....200-202, 281  
 GLUE GUN .....189  
 GLUES .....189  
 GOGGLES .....207  
 GORILLA GLUE .....189  
 GREASE .....188, 191, 192, 328  
 GREASE FITTINGS .....330  
 GREASE FITTING REMOVER .....329, 382  
 GREASE GUNS & ACCESSORIES .....328-329  
 GRINDERS, ANGLE .....284-286, 292  
 GRINDERS, BENCH .....287-288  
 GRINDING WHEELS .....SEE "ABRASIVES"  
 GROMMETS .....253  
 GROUND CLAMPS .....280

**H**

HACKSAW BLADES .....140  
 HACKSAWS .....140  
 HAIRPIN COTTERS .....85  
 HALOGEN WORKLIGHTS .....245  
 HAMMERS .....384-386  
     ECONOMY .....374  
 HAMMERS, WELDING CHIPPING .....280  
 HAMMER DRILLS .....282, 285-286, 290-291  
 HAMMER HOLDER .....204  
 HAND CLEANERS / DISPENSERS .....188, 198-199  
 HANDPADS .....103  
 HAND TRUCKS .....398-399  
 HANDLES:  
     CHEST & DRAWER .....234-235  
     FILE .....144, 146  
     REPLACEMENT TOOL .....387-388  
 HANGER STRAP .....229  
 HARDHAT LIGHT .....243  
 HARDHAT LINERS .....210  
 HARDHATS .....205

**H**

HARNESS, BODY .....212  
 HASPS .....234  
 HEARING PROTECTION .....210  
 HEAT ABSORBING PASTE .....184  
 HEAT CABLE .....279  
 HEAT GUNS .....279  
 HEAT SHRINK TUBING .....253  
 HEATER HOSE .....314  
 HEATERS .....402  
 HEDGE TRIMMER .....407  
 HELICOILS .....90  
 HEX KEYS & SETS .....162, 375-377  
 HINGES .....234-235  
 HI-SPOT BLUE .....173  
 HITCH PINS .....86  
 HOES .....406, 408  
 HOLE CUTTERS .....113, 309  
 HOLE PUNCHERS .....171  
 HOLESAWS & ACCESSORIES .....138-139  
 HOISTS .....223  
 HONES, CYLINDER .....382  
 HOOKS:  
     CHAIN / SNAP .....224-228, 231-232  
     STORAGE .....233  
 HOSE:  
     AIRLINE .....314  
     COIL .....310  
     DISCHARGE .....264  
     PNEUMATIC .....305  
     WATER .....264  
     WELDING .....280  
 HOSE BARBS .....305, 318  
 HOSE CLAMPS .....314  
 HOSE FAUCET .....339  
 HOSE HANGER .....264  
 HOSE NOZZLE .....264  
 HOSE REELS .....314  
 HYDRAULIC JACKS .....289  
 HYDRAULIC OIL .....197  
 HYDRAULIC SEALANT .....185

**I**

ICE MELTERS .....183, 197  
 IMPACT DRIVER .....348  
 IMPACT WRENCH, AIR .....294  
 IMPACT WRENCH, CORDLESS .....290-291  
 IMPACT WRENCH, ELECTRIC .....286  
 INSECT REPELLENT .....175  
 INSERTS, CARBIDE & CERAMIC .....131-132  
 INSULATING VARNISH .....175  
 INVISIBLE GLOVE .....199

**J**

JACKS, HYDRAULIC .....289  
 JANITORIAL CHEMICALS .....179-182  
 JEWELER'S SCREWDRIVERS .....348  
 JIGSAW BLADES .....140  
 JIGSAWS .....284  
 JUMPER CABLES .....256

**K**

KEY CADDY .....168  
 KEY RINGS .....168, 170  
 KEYSTOCK .....81  
 KNEE PADS .....204  
 KNIVES .....149-150  
 KNOCKOUT PUNCHES .....380

**L**

LACQUER THINNER .....183  
 LADDERS .....396-397  
 LAG BOLTS .....SEE "SCREWS"  
 LANDSCAPE RAKES .....406  
 LANYARDS .....212  
 LAYOUT FLUID .....173, 177  
 LEAK DETECTOR .....185  
 LEAK REPAIR PRODUCTS .....189-190  
 LENS CLEANING PRODUCTS .....205  
 LEVELS .....161, 168-169  
 LIFTER'S BELTS .....212  
 LIFTING CLAMPS .....226  
 LIGHTBULBS .....SEE "BULBS"  
 LIME REMOVER .....180, 182, 183  
 LINE REELS .....168  
 LINERS, WINTER .....210  
 LIGHTS:  
     12V SPOTLIGHT .....247  
     BARRICADE .....216  
     HALOGEN.....245  
     PORTABLE WORK .....245-248  
     TEMPORARY .....245  
     WORKBENCH .....247  
 LOAD BINDERS .....228  
 LOCKOUTS & TAGS .....239  
 LOCKS .....237-239  
 LOCKWIRE .....156  
 LOCTITE .....SEE "THREAD SEALANTS"  
 LOPPING SHEARS .....408  
 LPS PRODUCTS .....192  
 LUBRICANTS.....191-195  
 LUMBER CRAYONS .....172  
 LUTE RAKES .....406  
 LYSOL .....181

**M**

MACHINE SCREWS .....SEE "SCREWS"  
 MACHINERY BUSHINGS .....87  
 MAG DRILL .....307-308  
 MAG DRILL CUTTERS .....113, 309  
 MAGIC MARKERS .....172  
 MAGNETS:  
     PICKUP TOOL / LIFTING .....154, 226, 381  
     POT .....154  
 MAGNETIC BASE .....158  
 MAGNIFYING GLASSES .....154, 247  
 MARKERS .....172-173  
 MARKING PAINTS .....177  
 MARKING WAND .....177  
 MASONRY ANCHORS .....92-96  
 MASONRY DRILL BITS .....114  
 MATTOCKS .....391  
 MEASURING WHEELS .....169  
 MECHANIC'S STETHOSCOPE .....381  
 MECHANICS'S WIRE .....229  
 MENDING BRACES .....234-236  
 METATARSAL GUARDS .....211  
 METERS .....163-165  
 METRIC FASTENERS .....57-77  
 MICROMETERS .....159-160  
 MIRRORS, INSPECTION .....381  
 MIST COOLANT UNIT .....310  
 MOLD RELEASE .....176  
 MOP BUCKET .....261  
 MOPS .....261, 270  
 MORTAR HOES .....406, 408  
 MOTOR ARBORS .....88  
 MOTOR COUPLINGS .....88  
 MOUNTED POINTS .....99  
 MURIATIC ACID .....183  
 MURPHY'S OIL SOAP .....181  
 MUSIC WIRE .....156

**N**

NAIL PULLERS .....391  
 NAILS/STAPLES.....302-304  
 NAILERS/STAPLERS.....296-301  
 NAILERS/STAPLERS ACCESSORIES.....305-306  
 NORD-LOCK WASHERS.....18  
 NUT CRACKER .....382  
 NUT DRIVER .....348  
 NUT DRIVER SET ECONOMY .....374  
 NUTS:  
     A325.....21  
     BRASS.....54-55  
     CAP (ACORN) .....20, 41, 55  
     HEX .....19-22, 41, 54-56  
     LOCK .....21-22, 41, 54  
     METRIC .....68  
     METRIC, STAINLESS .....73



N

NUTS (CONTINUED):  
 MISCELLANEOUS .....21-23  
 NYLON .....56  
 ROD COUPLING .....23, 41  
 SQUARE .....22  
 STAINLESS .....41  
 T-SLOT .....394  
 TEE PRONG .....22  
 WING .....22, 41, 55  
 NUT SETTERS .....350  
 NUTSERTS .....91  
 NYLON AIR BRAKE FITTINGS .....327  
 NYLON FASTENERS .....56

O

OETIKER CLAMPS .....314  
 OIL DISPENSING CANS .....410  
 OIL DRI .....257  
 OIL FILTER WRENCHES .....382  
 O-RINGS .....83  
 OILS:  
 3-IN-1 .....193  
 AIR TOOL .....193  
 CUTTING .....193-195, 379  
 HYDRAULIC .....197  
 JACK .....289  
 LPS .....192  
 MARVEL MYSTERY OIL .....196  
 MOTOR .....196  
 PNEUMATIC.....305  
 TRI-FLOW .....193  
 WD-40 .....193  
 WATER SOLUBLE .....194-195  
 OILERS, PUMP .....410  
 OPEN GEAR/CHAIN LUBE .....174  
 OVERSIZE/WIDE LOAD BANNER .....216

P

PAINT .....177-178  
 PAINT CAN, EMPTY.....178  
 PAINT MIXER.....178  
 PAINT ROLLERS/TRAYS .....274  
 PAINT REMOVER .....175  
 PAINT THINNER .....183  
 PAINTSTICK MARKERS .....172  
 PALLET JACK .....289  
 PALLET PULLER .....221  
 PAPER CUPS .....412  
 PAPER TOWELS /WIPERS.....262-263  
 PARTS WASHER SOLVENT .....183  
 PEDESTAL, GRINDER .....287-288  
 PEGBOARD HOOKS .....233  
 PENCIL, CARPENTER .....172  
 PENETRANTS .....174, 191-193

P

PENNANTS .....212  
 PERMATEx PRODUCTS .....185, 188  
 PHONE .....105  
 PIANO HINGE .....235  
 PICKINGTOOL.....162,347,382  
 PICKS .....391  
 PICK-UP TOOLS .....154, 381  
 PIN VISE .....154, 162, 283  
 PINESOL .....181  
 PINS:  
 CLEVIS .....85  
 COTTER .....47, 85  
 DOWEL .....40, 48, 66  
 HITCH .....86  
 POWDER ACTUATED .....96  
 SPRING.....47,71-72,86  
 TAPER .....87  
 PIPE CLAMP FIXTURE .....392  
 PIPE CLAMPS .....339  
 PIPE CUTTERS .....378  
 PIPE FITTINGS:  
 BRASS .....320-321  
 STAINLESS STEEL .....337-338  
 STEEL .....332-337  
 PIPE HANGERS .....339  
 PIPE JOINT COMPOUND .....185  
 PIPE REAMERS .....378  
 PIPE THREADERS .....378-379  
 PIPE VISE .....379  
 PIPE WRENCHES .....378  
 ECONOMY .....372  
 PITCHFORKS .....407  
 PLATE LIFTING CLAMPS .....226  
 PLATES, STYROFOAM .....262  
 PLEDGE .....181  
 PLIERS .....314, 341-345  
 ECONOMY .....374  
 PLIERS, WIRE STRIPPING .....254, 342  
 PLUMB BOBS .....153  
 POLYFILM .....268  
 POP RIVETS & TOOLS .....82  
 PORTABAND SAW .....285  
 POSTHOLE DIGGERS .....407  
 POWDER ACTUATED TOOLS & ACCESSORIES .....96  
 POWER BITS & HOLDERS .....349-350  
 POWER STRIP.....250  
 POWER TOOLS:  
 AIR .....294-296  
 CORDLESS .....290-291  
 ELECTRIC .....282, 284-286, 292  
 PNEUMATIC.....297-302  
 PROPANE TORCHES .....277  
 PROTRACTORS .....154-155, 160-161  
 PRUNING TOOLS .....408  
 PRUSSIAN BLUE .....173

**P**

PRY BARS .....391  
 PULLEYS, ROPE & CABLE .....219  
 PUMPS .....265-266  
 PUNCH & CHISEL HOLDER .....383  
 PUNCHES:  
   CENTER .....153, 389  
   HOLE .....171  
   LINING .....389  
   PIN.....153, 389  
   TRANSFER .....171  
   PUNCHES & SETS .....389-390  
 PUSH-IN FITTINGS .....326  
 PUTTY KNIVES .....151  
 PVC CEMENT .....184

**R**

RADIATOR FILLER .....411  
 RADIATOR SEALANT .....197  
 RAGS .....262  
 RAINSUITS .....210  
 RAKES .....406  
 RATCHET SLINGS .....220  
 RATCHETING BOX WRENCHES .....353  
 RATCHETS, AIR .....296  
 RATCHETS & ACCESSORIES.355,360,364-365,367-368  
 RATCHETS, ECONOMY .....373  
 RAWHIDE HAMMERS .....384, 386  
 RAZOR BLADES .....149  
 REAMER, PIPE .....378  
 REAMERS .....125  
 RECIPROCATING BLADES .....140  
 RECTOR SEAL .....185  
 REEL LIGHTS .....248  
 REFERENCE BOOK .....381  
 REFERENCE GAUGE .....154  
 REFLECTORS .....213  
 REGULATORS, AIRLINE.....313  
 RESPIRATORS .....209  
 RETHREAD DIES .....121, 122  
 RIVETS & TOOLS .....82  
 ROAD SAFETY .....215-216  
 ROCK SALT .....183  
 ROLL PINS .....47, 71-72, 86  
 ROLL TOWEL DISPENSER .....262  
 ROLLER, PAVING .....408  
 ROLLER CHAIN .....228  
 ROPE .....218  
 ROUND BAR .....81  
 ROUTER BITS .....142-143  
 RUBBERDRUM.....102  
 RUBBER REPAIR PRODUCTS .....189  
 RULES .....155, 166-169  
 RUST CONVERTER .....178  
 RUST PREVENTER .....174

**S**

S-HOOKS .....170, 224, 233  
 SAFETY EQUIPMENT .....205-217  
 SAFETY FENCE .....215  
 SAFETY GLASSES .....207-208  
 SAFETY HARNESS & ACCESSORIES .....212  
 SALT, ROCK.....183  
 SANDERS, AIR .....295  
 SANDING BANDS .....SEE "ABRASIVES"  
 SANDING DISCS .....SEE "ABRASIVES"  
 SANDING PAPER .....SEE "ABRASIVES"  
 SANDINGBELTS .....101  
 SAW BLADES - CIRCULAR .....141  
 SAWS:  
   BOW .....407  
   CIRCULAR .....285  
   CHOP .....292  
   FOLDING .....140  
   HACK .....140  
   HAND CROSSCUT .....140  
   METAL CUTTING .....292  
   PVC .....140  
   PORTABAND .....285  
 SAWZALL BLADES .....140  
 SAWZALL TOOL .....285  
 SCALER, AIR .....296  
 SCISSORS .....152  
 SCRAPERS:  
   FLOOR .....405  
   GASKET .....382  
   HAND .....151  
   RAZOR BLADE .....149  
 SCREW EXTRACTOR & SETS.....124  
 SCREW GUN .....286  
 SCREW PITCH GAUGES .....157  
 SCREW STARTERS .....348  
 SCREWDRIVERS .....162, 346-348, 350  
   ECONOMY .....374  
 SCREWDRIVER SOCKETS .....358, 365  
 SCREWS:  
   CABINET .....24  
   DECK/DRYWALL .....24  
   DRILL POINT .....26  
   DRIVE .....24, 82  
   FLOORBOARD .....25  
   LAG .....24, 46  
   LICENSE PLATE .....24  
   MACHINE .....28-31, 49-52, 56  
   METRIC, MACHINE .....70  
   METRIC, SOCKET .....64-66  
   METRIC, STAINLESS .....74-77  
   SHEET METAL .....26-28, 48-49  
   SOCKET HEAD .....32-34, 44-46  
   SOCKET BUTTON HEAD .....35, 45, 65, 75-76  
   SOCKET FLAT HEAD .....36, 45, 64-65, 75  
   SOCKET LOW HEAD .....37, 66

S

SCREWS (CONTINUED):

- SOCKET SET .....37-39, 67, 76—
- SOCKET SHOULDER.....39-40
- SQUARE HEAD SET .....39
- TAMPERPROOF .....28
- THREAD CUTTING .....24
- THUMB .....24
- WOOD .....24-26, 55

SCRIBERS .....153, 162

SEALANTS .....186-190

SHAFT:

- ARBORS.....88
- BUSHINGS .....87-88
- COLLARS .....87
- COUPLINGS .....88
- KEY.....88

SHEET METAL SCREW .....SEE "SCREWS"

SHEET METAL VISE GRIPS .....343

SHELF BINS .....413

SHELLAC .....178

SHELVING .....235

SHIM STOCK .....156

SHOP ROLLS .....101

SHOP VACS .....269

SHOVELS .....403-405, 408

SHRINK WRAP .....268

SIGNS .....213-216, 260

SILICONE SEALANTS .....186-188

SILICONE SPRAY .....176

SIMPLE GREEN.....182

SLEDGE HAMMERS .....385

SLIDING ARM CLAMPS .....393

SLINGS .....220-221

SMOKERS RECEPTACLE.....259

SNAP RING PLIERS .....345

SNAP RINGS & KITS .....84

SNAPS .....231-232

SNOW BRUSHES/SCRAPERS .....256

SNOW SHOVELS .....405

SOAP, HAND.....188, 198-199

- LAVA BAR.....198

SOAPSTONE.....172

SOCKET CAP SCREWS .....SEE "SCREWS"

SOCKET HOLDERS .....371

SOCKET SET SCREWS .....SEE "SCREWS"

SOCKETS & SETS .....354-371

- ECONOMY .....373

SOLDER PRODUCTS .....184

SOLDERING TOOLS .....278

SPANNER WRENCHES .....100, 284, 371

SPONGES .....260

SPRAY BOTTLES .....260

SPRAY GUN, HYDRO BLAST .....310

S

SPRAY PRODUCTS:

- ADHESIVE .....175
- AIR FRESHENERS .....179
- ANTI-SEIZE .....174
- ANTI-SPLATTER .....175
- BATHROOM DISINFECTANT.....179, 181
- BELT DRESSING .....174
- CARPET CLEANER .....181
- CHAIN LUBE .....174
- CLEAR ACRYLIC .....175
- CONTACT CLEANER .....176
- CRACK DETECTOR .....176
- CUTTING OIL .....174
- DEGREASER.....175, 180, 196
- DE-ICER .....197
- DRY GRAPHITE .....174
- DRY MOLY .....174
- GALVANIZE .....175
- GEAR/ROPE LUBE .....174
- INSECTICIDE .....175
- LAYOUT FLUID .....173, 177
- LUBRICANTS .....174, 191-193
- MAGNUM GREEN.....180
- MOLD RELEASE .....176
- MOP & CLOTH TREATMENT .....181
- PAINT .....177-178
- PENETRANTS .....174, 192-193
- PAINT/GASKET REMOVER .....175
- RUST PREVENTATIVE .....174, 192
- SILICONE .....176
- STENCIL INKS .....177
- STRIPING PAINT .....177
- TEFLON LUBE .....174
- UNDERCOAT .....187
- VARNISH .....175
- WHITE GREASE .....174, 191
- WINDOW CLEANER .....179

SPRAYERS, TANK .....267

SPREADERS .....183, 408

SPRING CLAMPS .....392

SPRING PINS .....47, 71-72, 86

SPRINGS .....89

SPUD BARS .....391

SQUARES .....155, 160-161, 169

SQUEEGEES .....260

STAINLESS STEEL FASTENERS .....41-52, 73-77

STAIR GAUGES .....154

STAMPS .....170

STAPLES/NAILS.....302-304

STAPLERS / NAILERS .....296-301

STAPLERS/NAILERS ACCESSORIES.....305-306

STARTING FLUID .....196

STEEL WOOL .....103

STENCIL INK - AEROSOL .....177

**S**

STENCILS .....170  
 STEP DRILLS .....113  
 STETHOSCOPE, MECHANICS .....381  
 STODDARD SOLVENT .....183  
 STONES, ABRASIVE .....99, 100  
 STOP PADDLES .....215  
 STORAGE BINS .....413-414  
 STORAGE HOOKS.....233  
 STP OIL ADDITIVE .....196  
 STRAP WRENCHES .....378  
 STRAPPING .....229  
 STRETCH WRAP .....268  
 STRIKERS .....277, 280  
 STRIKING BOX WRENCHES .....353  
 STRIP DOORS .....402  
 STRIPING PAINTS & MACHINES .....177  
 STROBE LIGHT .....216  
 STRUCTURAL ADHESIVES .....189  
 STRUT & FITTINGS .....339  
 STUDS, THREADED .....81  
 SUCTION GUN .....328  
 SUMP PUMPS .....265-266  
 SUPERKNIFE .....149  
 SUPPORT BELTS .....212  
 SURFACE CONDITIONING PRODUCTS .....103-104  
 SUSPENDERS .....204  
 SWAGER TOOL, WIRE ROPE .....221  
 SWEATBANDS .....210  
 SWEEPING COMPOUND .....257  
 SWIVELS, AIRLINE .....310

**T**

T-BEVEL, SLIDING .....154  
 T-SLOT NUTS, BOLTS .....394  
 TAGS .....170  
 TAMPERPROOF SCREWS .....28  
 TAMPERPROOF TOOLS .....349-350  
 TAMPERS .....407  
 TAP & DIE SETS .....117, 120  
 TAP EXTENSIONS .....117, 123  
 TAP EXTRACTORS .....123  
 TAP WRENCHES .....123  
 TAPCONS.....96  
 TAPE:  
 ANTI-SKID .....212  
 CARTON SEALING .....258  
 CAUTION .....213  
 DISPENSER .....258  
 DOUBLE-FACED .....258  
 DUCT .....258  
 ELECTRICAL .....253  
 FOAM .....258  
 FILAMENT .....258  
 GAFFERS .....258

**T**

TAPE (CONTINUED):  
 HAZARD STRIPE .....212  
 MASKING .....258  
 REFLECTIVE.....212  
 RULES .....166-167  
 SURVEYORS .....213  
 TEFLON .....185  
 TAPFREE PRODUCTS .....195  
 TAPER PINS .....87  
 TAPS .....116-120  
 TARP STRAPS .....220  
 TARPS, POLY .....268  
 TEFLON LUBE .....174  
 TEFLON PIPE SEALANT .....185  
 TEFLON TAPE .....185  
 TEMPERATURE STICKS .....172  
 TEST EQUIPMENT .....163-165  
 THERMOMETERS.....163  
 THIMBLES, WIRE ROPE .....222  
 THINNER .....173, 183  
 THREAD CUTTING OIL, RIDGID .....193, 379  
 THREAD REPAIR INSERTS .....90-91  
 THREAD REPAIR TOOLS .....122  
 THREAD SEALANTS:  
 LOCKING .....186, 188  
 PIPE .....185  
 THREADED ROD .....56, 78-79  
 TIE DOWNS .....220  
 TIE MOUNTS .....255  
 TIE WIRE .....229  
 TIN CANS, EMPTY.....178, 411  
 TIN SNIPS .....344  
 TIP CLEANER .....277  
 TIRE GAUGES & CHUCKS .....310  
 TIRE SEALANTS .....197  
 TOGGLE CLAMPS .....394  
 TOILET BOWL CLEANERS .....179  
 TOILET PLUNGER .....261  
 TOILET TISSUE .....262  
 TOOL BALANCER.....308  
 TOOL BITS .....131  
 TOOL BOXES .....413  
 TOOL DIP .....178  
 TOOL POUCHES .....203-204  
 TORCHES:  
 BUTANE .....278  
 PROPANE .....277  
 TORQUE WRENCHES .....371  
 TORX:  
 FOLD-UP KEY SET .....375  
 INSERT BIT .....349  
 SCREWDRIVER SET .....347  
 SECURITY WRENCH .....350  
 SOCKET SET .....348

T

TOTETRAY.....259  
 TRAMMELPOINTS.....153  
 TRANSFERPUNCHES.....171  
 TRASH BAGS.....268  
 TRASH CANS.....259  
 TREE TRIMMER.....408  
 TRIANGLE WARNING KIT.....215  
 TRI-FLOW LUBRICANT.....193  
 TROUBLE LIGHTS.....247-248  
 TROWELS.....151  
 TUBE BRUSHES.....276  
 TUBING BENDERS.....380  
 TUBING CLAMPS.....255  
 TUBING CUTTERS & WHEELS.....379  
 TUBING:  
     AIR BRAKE.....327  
     COPPER.....323, 327  
     NYLON.....323  
     POLY.....323  
     VINYL.....323  
 TURNBUCKLES.....222  
 TWINE.....218

U

U-BOLTS.....233  
 UNDERCOAT SPRAY.....187  
 UNIBITS.....113  
 UNISTRUT & FITTINGS.....339  
 UNTHREADED ROD.....81  
 URINAL BLOCKS.....262  
 UTILITY KNIVES/BLADES.....149-150

V

V-BELTS.....316  
 VACUUMS.....269  
 VARNISH.....175  
 VALVES.....310, 319, 340  
 VELCRO.....255  
 VESTS, SAFETY.....216  
 VISE GRIP TOOLS.....343  
 VISES:  
     BENCH.....395  
     DRILL PRESS.....287, 395  
     PIN.....283  
     PIPE.....379  
 VISQUEEN.....268  
 VOLTAGE TESTER.....165

W

WARNING TRIANGLE KIT.....215  
 WASHERS:  
     BELLEVILLE.....18  
     BEVEL (SQUARE).....18  
     BRASS.....54  
     COPPER.....54  
     EXTRA THICK.....16  
     FENDER.....16, 42  
     FINISHING.....16, 42, 54  
     FLAT.....16, 42, 54, 69  
     LOCK.....17, 42, 54, 69  
     METRIC.....69  
     METRIC, STAINLESS.....73  
     NORD-LOCK.....18  
     NYLON.....56  
     SEALING.....26, 42  
     STAINLESS.....42  
 WASP & HORNET SPRAY.....175  
 WASTE BASKETS.....259  
 WATER COOLERS & JUGS.....412  
 WATER SOLUBLE.....194-195  
 WAY LUBRICANT.....194  
 WAX STICK (EDGE LUBE).....191  
 WD-40 PRODUCTS.....191, 193  
 WEATHERSTRIP ADHESIVE.....187  
 WEDGES, STEEL.....385  
 WEED TRIMMER.....407  
 WELDING CLAMPS.....280, 393  
 WELDING SUPPLIES:  
     CABLE.....280  
     CLOTHING.....205, 281  
     CYLINDER TRUCKS.....398  
     GLOVES.....201, 280  
     GOGGLES.....280  
     HAMMERS.....280  
     HOSE.....280  
     HELMETS.....207, 280  
     LENSES.....207, 280  
     MAGNETIC SQUARES.....280, 394  
     ROD.....280  
 "WET FLOOR" SIGNS.....260  
 WHEEL CHOCK.....216  
 WHEEL DRESSER.....98  
 WHEEL GUARDS.....284-285  
 WHEELBARROWS.....409  
 WHISK BROOMS.....270  
 WHITE GREASE.....174, 191  
 WIGGY TESTER.....165  
 WINDOW CLEANERS.....179  
 WINDSHIELD WASHER FLUID.....197  
 WINTER LINERS.....210

**W**

WIRE:

- AUTO PRIMARY .....254—
- ELECTRICAL .....250
- LOCK .....156
- MECHANICS .....229
- PIANO .....156
- TIE .....229

WIRE BRUSHES, HAND .....184, 273

WIRE END BRUSHES .....275

WIRE LOOM .....253

WIRE MARKERS .....253

WIRE NUTS .....251

WIRE ROPE / SLINGS.....221

WIRE STRIPPERS / CRIMPERS .....254

WIRE TERMINAL PLIERS .....254

WIRE TERMINALS .....251-252

WIRE WHEELS .....275-276

WOODRUFF KEYS .....88

WOOD SCREWS .....”SEE SCREWS”

WRENCHES:

- OIL FILTER .....256, 382
- TAP .....123
- WRENCHES & SETS .....351-353
- ECONOMY .....372

WRINGERS .....261

**X**

XYLENE .....183

**Y**

YOKE ENDS .....85

**Z**

ZOOM SPOUT OILER .....192

**TRADE PRACTICES**

- ORDERS:** PLEASE SPECIFY COMPLETE INFORMATION ON QUANTITY, SIZE, PART NUMBERS, DESCRIPTIONS, SHIPPING INFORMATION, AND REQUIRED DELIVERY DATES.
- PRICES:** WE HAVE OMITTED PRICES FROM THIS CATALOG. CURRENT PRICES WILL BE FURNISHED UPON REQUEST.
- QUOTATIONS:** QUOTATIONS ARE MADE FOR PROMPT ACCEPTANCE AND SUBJECT TO CHANGE WITHOUT NOTICE UNLESS A SPECIFIED DATE IS GIVEN.
- TAXES:** SALES AND USE TAX WILL BE ADDED TO THE INVOICE UNLESS WE HAVE ON FILE THE PROPER TAX EXEMPTION CERTIFICATE.
- CANCELLATIONS:** ORDERS FOR SPECIAL OR NON-STANDARD MERCHANDISE CANNOT BE CANCELLED WITHOUT THE PERMISSION OF THE MANUFACTURER. CANCELLATION CHARGES MAY BE ASSESSED TO STANDARD TRADE PRACTICE.

**RESPONSIBILITY**

IT IS OUR POLICY TO REPRESENT RELIABLE MANUFACTURERS. THE GUARANTEES AGAINST DEFECTIVE MATERIALS PROVIDED BY THESE MANUFACTURERS WILL PREVAIL. WE LIMIT OUR LIABILITY TO THESE GUARANTEES. WE ASSUME NO LIABILITY FOR DAMAGE TO PERSON OR PROPERTY CAUSED BY MERCHANDISE BOUGHT FROM OR THROUGH US. STATISTICAL INFORMATION CONTAINED IN THIS CATALOG IS DERIVED FROM MANUFACTURERS' DATA AND PRINTED SOLELY FOR OUR CUSTOMERS' CONVENIENCE. SELECTION OF ITEMS FOR A PARTICULAR USE IS AT THE SOLE DISCRETION AND RISK OF THE PURCHASER.

**TO HAVE AN OPEN ACCOUNT**

WE REQUIRE THAT ALL CUSTOMERS MUST SUBMIT AT LEAST THREE (3) REFERENCES, PLUS A BANK REFERENCE. THERE IS A \$15.00 SERVICE CHARGE FOR ALL NSF CHECKS.

- ◆ OUR TERMS: NET 30 DAYS
- ◆ ANY PAST DUE INVOICES OR RETURNED CHECKS MAY CAUSE YOUR OPEN ACCOUNT TO BE CHANGED TO C.O.D.
- ◆ IF ANY ACCOUNT IS PAST 30 DAYS PAST DUE, NO SHIPMENTS WILL BE MADE, AND ALL FUTURE PURCHASES MAY BE C.O.D.
- ◆ WE ACCEPT MASTER CARD AND VISA CREDIT CARDS.
- ◆ THE MINIMUM CHARGE FOR A CREDIT CARD TRANSACTION IS \$10.00.







**GRADE 2 LOW CARBON  
HEX HEAD CAP SCREWS**  
NATIONAL COARSE (USS)



STOCK NO.	LENGTH	BOX QTY.	STOCK NO.	LENGTH	BOX QTY.	STOCK NO.	LENGTH	BOX QTY.
<b>1/4-20 NATIONAL COARSE</b>			<b>5/16-18 NATIONAL COARSE</b>			<b>3/8-16 NATIONAL COARSE</b>		
H2001	3/8	100	H2021	1/2	100	-	1/2	-
H2002	1/2	100	H2022	5/8	100	H2040	5/8	100
H2003	5/8	100	H2023	3/4	100	H2041	3/4	100
H2004	3/4	100	H20235	7/8	100	H20415	7/8	100
H2005	7/8	100	H2024	1"	100	H2042	1"	100
H2006	1"	100	H2025	1-1/4	100	H2043	1-1/4	100
H2007	1-1/4	100	H2026	1-1/2	100	H2044	1-1/2	100
H2008	1-1/2	100	H2027	1-3/4	100	H2045	1-3/4	50
H2009	1-3/4	100	H2028	2"	100	H2046	2"	50
H2010	2"	100	H2029	2-1/4	100	H2047	2-1/4	50
H2011	2-1/4	100	H2030	2-1/2	50	H2048	2-1/2	50
H2012	2-1/2	100	H2031	2-3/4	50	H2049	2-3/4	50
H2013	2-3/4	100	H2032	3"	50	H2050	3"	50
H2014	3"	100	H2033	3-1/4	50	H2051	3-1/4	50
-	3-1/4	-	H2034	3-1/2	50	H2052	3-1/2	25
H2015	3-1/2	50	-	3-3/4	-	-	3-3/4	-
-	3-3/4	-	H2035	4"	50	H2053	4"	25
H2016	4"	50	H2036	4-1/2	50	H2054	4-1/2	25
H2017	4-1/2	50	H2037	5"	50	H2055	5"	25
H2018	5"	50	H2038	5-1/2	50	H2056	5-1/2	25
-	5-1/2	50	H2039	6"	50	H2057	6"	25
H2020	6"	50	-	7"	-	H20572	7"	25
H20205	7"	50	-	8"	-	-	7-1/2	-
						-	8"	-
						-	9"	-
						-	10"	-
						-	11"	-
						-	12"	-

STOCK NO.	LENGTH	BOX QTY.	STOCK NO.	LENGTH	BOX QTY.	STOCK NO.	LENGTH	BOX QTY.
<b>1/2-13 NATIONAL COARSE</b>			<b>5/8-11 NATIONAL COARSE</b>			<b>3/4-10 NATIONAL COARSE</b>		
H2058	3/4	50	H2079	1"	25	H2096	1"	25
H2059	1"	50	H2080	1-1/4	25	H2097	1-1/4	25
H2060	1-1/4	50	H2081	1-1/2	25	H2098	1-1/2	25
H2061	1-1/2	50	H2082	1-3/4	25	H2099	1-3/4	20
H2062	1-3/4	50	H2083	2"	25	H2100	2"	20
H2063	2"	50	H2084	2-1/4	25	H2101	2-1/4	20
H2064	2-1/4	25	H2085	2-1/2	25	H2102	2-1/2	20
H2065	2-1/2	25	H2086	2-3/4	25	H2103	2-3/4	20
H2066	2-3/4	25	H2087	3"	25	H2104	3"	20
H2067	3"	25	H20875	3-1/4	25	H2105	3-1/4	20
H2068	3-1/4	25	H2088	3-1/2	25	H2106	3-1/2	20
H2069	3-1/2	25	H2089	4"	25	H2107	3-3/4	20
H2070	3-3/4	25	H2090	4-1/2	25	H2108	4"	20
H2071	4"	25	H2091	5"	25	H2109	4-1/2	15
H2072	4-1/2	25	H2092	5-1/2	25	H2110	5"	15
H2073	5"	25	H2093	6"	25	H2111	5-1/2	15
H2074	5-1/2	25	H20935	6-1/2	25	H2112	6"	15
H2075	6"	25	-	7"	-	H2113	6-1/2	15
H20751	6-1/2	25	-	7-1/2	-	H2114	7"	15
H2076	7"	25	-	8"	-	-	8"	-
H2077	8"	25	-	9"	-	-	9"	-
H20772	9"	25	-	10"	-	-	10"	-
H20774	10"	25	-	12"	-	-	12"	-
-	11"	25						
H20776	12"	25						



**GRADE 2 LOW CARBON  
HEX HEAD CAP SCREWS**  
NATIONAL COARSE (USS)



STOCK NO.	LENGTH	BOX QTY.	STOCK NO.	LENGTH	BOX QTY.	STOCK NO.	LENGTH	BOX QTY.
<b>7/8-9 NATIONAL COARSE</b>			<b>1"-8 NATIONAL COARSE</b>					
H2116	2	-	H2124	2"	-	<b>1-1/8-7 NATIONAL COARSE</b>  <b>1-1/4-7 NATIONAL COARSE</b>  <b>1-1/2-6 NATIONAL COARSE</b>  LIMITED SIZES ON GRADE 2. CALL FOR AVAILABILITY OR SEE GRADE 5 SIZES		
-	2-1/4	-	H2125	2-1/4	-			
H21162	2-1/2	-	H2126	2-1/2	-			
H21163	2-3/4	-	H2128	3"	-			
H2117	3	-	H2130	3-1/2	-			
H21171	3-1/4	-	H2131	4"	-			
H21174	3-1/2	-	H2132	4-1/2	-			
H211745	3-3/4	-	H2133	5"	-			
H21175	4	-	H2134	5-1/2	-			
H2118	4-1/2	-	H2135	6"	-			
-	5	-	H2136	7"	-			
H2120	5-1/2	-	H2137	7-1/2	-			
-	6	-	H2138	8"	-			
-	7	-	-	9"	-			
H21205	7-1/2	-	H2142	10"	-			
			-	12"	-			

ADDITIONAL SIZES AVAILABLE UPON REQUEST

**SERVICE WITH A SMILE.**





**GRADE 2 LOW CARBON  
FULLY THREADED HEX HEAD TAP BOLTS**  
NATIONAL COARSE (USS)



STOCK NO.	LENGTH	BOX QTY.	STOCK NO.	LENGTH	BOX QTY.	STOCK NO.	LENGTH	BOX QTY.
<b>1/4-20 NATIONAL COARSE</b>			<b>5/16-18 NATIONAL COARSE</b>			<b>3/8-16 NATIONAL COARSE</b>		
TB2001	1-1/4	100	TB2031	1-1/4	100	TB2061	1-1/4	100
TB2002	1-1/2	100	TB2032	1-1/2	100	TB2062	1-1/2	100
TB2003	1-3/4	100	TB2033	1-3/4	100	TB2063	1-3/4	100
TB2004	2"	100	TB2034	2"	100	TB2064	2"	50
2005	2-1/4	-	2035	2-1/4	-	TB2065	2-1/4	50
TB2006	2-1/2	100	TB2036	2-1/2	100	TB2066	2-1/2	50
2007	2-3/4	-	2037	2-3/4	-	2067	2-3/4	-
TB2008	3"	100	TB2038	3"	50	TB2068	3"	50
2009	3-1/4	-	2039	3-1/4	-	2069	3-1/4	-
2010	3-1/2	-	TB2040	3-1/2	50	TB2070	3-1/2	50
2011	3-3/4	-	2041	3-3/4	-	2071	3-3/4	-
TB2012	4"	100	TB2042	4"	50	TB2072	4"	50
2014	4-1/2	-	2044	4-1/2	-	2074	4-1/2	-
2016	5"	-	TB2046	5"	50	TB2076	5"	50
2018	5-1/2	-	2048	5-1/2	-	2078	5-1/2	-
2020	6"	-	2050	6"	-	TB2080	6"	50
STOCK NO.	LENGTH	BOX QTY.	STOCK NO.	LENGTH	BOX QTY.	STOCK NO.	LENGTH	BOX QTY.
<b>1/2-13 NATIONAL COARSE</b>			<b>5/8-11 NATIONAL COARSE</b>			<b>3/4-10 NATIONAL COARSE</b>		
2091	1-3/4	-	2121	2"	-	2151	2-1/4	-
TB2092	2"	50	2122	2-1/4	-	2152	2-1/2	-
2093	2-1/4	-	TB2123	2-1/2	25	TB2153	3"	20
TB2094	2-1/2	50	2124	2-3/4	-	TB2154	3-1/4	20
2095	2-3/4	-	TB2125	3"	25	2155	3-1/2	-
TB2096	3"	50	2126	3-1/4	-	2156	3-3/4	-
2097	3-1/4	-	2127	3-1/2	-	TB2157	4"	20
TB2098	3-1/2	25	2128	3-3/4	-	2159	4-1/2	-
2099	3-3/4	-	TB2129	4"	25	TB2161	5"	20
TB2100	4"	25	2131	4-1/2	-	2163	5-1/2	-
2102	4-1/2	-	TB2133	5"	25	TB2165	6"	20
TB2104	5"	25	2135	5-1/2	-			
TB2106	5-1/2	25	TB2137	6"	25			
TB2108	6"	25						

**ADDITIONAL SIZES AVAILABLE UPON REQUEST**



**GRADE 5 HI CARBON  
FULLY THREADED HEX HEAD TAP BOLTS**  
NATIONAL COARSE (USS)



STOCK NO.	LENGTH	BOX QTY.	STOCK NO.	LENGTH	BOX QTY.	STOCK NO.	LENGTH	BOX QTY.
<b>5/16-18 NATIONAL COARSE</b>			<b>3/8-16 NATIONAL COARSE</b>			<b>1/2-13 NATIONAL COARSE</b>		
TB5040	3-1/2	100	TB5072	4"	-	TB5094	2-1/2	25
						TB5096	3"	25
						TB5098	3-1/2	50
						TB5100	4"	25
						TB5104	5"	25
						TB5108	6"	25

STOCK NO.	LENGTH	BOX QTY.	STOCK NO.	LENGTH	BOX QTY.	ADDITIONAL SIZES AVAILABLE UPON REQUEST
<b>3/4-10 NATIONAL COARSE</b>			<b>1"-8 NATIONAL COARSE</b>			
TB5153	3"	20	TB975	6"	-	ADDITIONAL SIZES AVAILABLE UPON REQUEST
TB5155	3-1/2	20				
TB5157	4"	20				
TB5161	5"	20				
TB5165	6"	25				

**GRADE 8 HI CARBON  
FULLY THREADED HEX HEAD TAP BOLTS**  
NATIONAL COARSE (USS)

STOCK NO.	LENGTH	BOX QTY.	ADDITIONAL SIZES AVAILABLE UPON REQUEST	ADDITIONAL SIZES AVAILABLE UPON REQUEST
<b>5/8-11 NATIONAL COARSE</b>				
TB8123	2-1/2	25		

**SEE WHY WE MAKE THE  
DIFFERENCE!**





**GRADE 5 HI CARBON  
HEX HEAD CAP SCREWS**  
NATIONAL COARSE (USS)

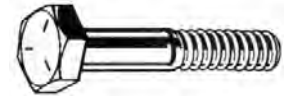

STOCK NO.	LENGTH	BOX QTY.	STOCK NO.	LENGTH	BOX QTY.	STOCK NO.	LENGTH	BOX QTY.
<b>1/4-20 NATIONAL COARSE</b>			<b>5/16-18 NATIONAL COARSE</b>			<b>3/8-16 NATIONAL COARSE</b>		
H50009	3/8	100	H5021	1/2	100	H5039	1/2	100
H5001	1/2	100	H50215	5/8	100	H50395	5/8	100
H5002	5/8	100	H5022	3/4	100	H5040	3/4	100
H5003	3/4	100	H50225	7/8	100	H50405	7/8	100
H5004	7/8	100	H5023	1"	100	H5041	1"	100
H5005	1"	100	H5024	1-1/4	100	H5042	1-1/4	100
H5006	1-1/4	100	H5025	1-1/2	100	H5043	1-1/2	100
H5007	1-1/2	100	H5026	1-3/4	100	H5044	1-3/4	50
H5008	1-3/4	100	H5027	2"	100	H5045	2"	50
H5009	2"	100	H5028	2-1/4	100	H5046	2-1/4	50
H5010	2-1/4	100	H5029	2-1/2	100	H5047	2-1/2	50
H5011	2-1/2	100	H5030	2-3/4	50	H5048	2-3/4	50
H5012	2-3/4	100	H5031	3"	50	H5049	3"	50
H5013	3"	100	H5032	3-1/4	50	H5050	3-1/4	25
H50135	3-1/4	100	H5033	3-1/2	50	H5051	3-1/2	25
H5014	3-1/2	50	-	3-3/4	-	H5052	3-3/4	25
H5015	4"	50	H5034	4"	50	H5053	4"	25
H5016	4-1/2	50	H5035	4-1/2	50	H5054	4-1/2	25
H5017	5"	50	H5036	5"	50	H5055	5"	25
H5018	5-1/2	50	H5037	5-1/2	50	H5060	5-1/2	25
H5019	6"	50	H5038	6"	50	H5061	6"	25
-	6-1/2	-	-	6-1/2	-	H5062	6-1/2	-
H5020	7"	-	-	7"	-	H50625	7"	-
						H50626	7-1/2	-
						H506265	8"	-
						-	8-1/2	-
						H50628	9"	-
						H50629	10"	-

STOCK NO.	LENGTH	BOX QTY.	STOCK NO.	LENGTH	BOX QTY.	STOCK NO.	LENGTH	BOX QTY.
<b>7/16-14 NATIONAL COARSE</b>			<b>1/2-13 NATIONAL COARSE</b>			<b>9/16-12 NATIONAL COARSE</b>		
H5063	3/4	100	H5081	3/4	50	H5103	1"	25
H5064	1"	50	H5082	1"	50	H5104	1-1/4	25
H5065	1-1/4	50	H5083	1-1/4	50	H5105	1-1/2	25
H5066	1-3/8	50	H5084	1-1/2	50	H5106	1-3/4	25
H5067	1-1/2	50	H5085	1-3/4	50	H5107	2"	25
H5068	1-3/4	50	H5086	2"	50	H51075	2-1/4	25
H5069	2"	50	H5087	2-1/4	25	H5108	2-1/2	25
H5070	2-1/4	25	H5088	2-1/2	25	H5109	2-3/4	25
H5071	2-1/2	25	H5089	2-3/4	25	H5110	3"	25
H5072	2-3/4	25	H5090	3"	25	H5111	3-1/4	25
H5073	3"	25	H5091	3-1/4	25	H5112	3-1/2	25
H50731	3-1/4	25	H5092	3-1/2	25	H5113	4"	25
H5074	3-1/2	25	H5093	3-3/4	25	H5114	4-1/2	25
-	3-3/4	-	H5094	4"	25	H5115	5"	25
H5075	4"	25	-	4-1/4	-	H51151	5-1/2	25
H5076	4-1/2	25	H5095	4-1/2	25	H51152	6"	25
H5077	5"	25	H5096	5"	25			
H5078	5-1/2	25	H5097	5-1/2	25			
H5079	6"	25	H5098	6"	25			
H50795	6-1/2	25	H5099	6-1/2	-			
H5080	7"	-	H5100	7"	-			
-	8"	-	H5101	7-1/2	-			
			H5102	8"	-			
			H51022	9"	-			
			H51024	10"	-			
			H51026	11"	-			
			H51028	12"	-			

**CALL US  
FOR ALL YOUR NEEDS**

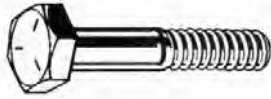
**GRADE 5 HI CARBON  
HEX HEAD CAP SCREWS**  
NATIONAL COARSE (USS)

STOCK NO.	LENGTH	BOX QTY.	STOCK NO.	LENGTH	BOX QTY.	STOCK NO.	LENGTH	BOX QTY.
<b>5/8-11 NATIONAL COARSE</b>			<b>3/4-10 NATIONAL COARSE</b>			<b>7/8-9 NATIONAL COARSE</b>		
H5116	1"	25	H5135	1"	25	-	1-1/2	-
H5117	1-1/4	25	H5136	1-1/4	25	H51558	1-3/4	-
H5118	1-1/2	25	H5137	1-1/2	25	H5156	2"	-
H5119	1-3/4	25	H5138	1-3/4	20	H51566	2-1/4	-
H5120	2"	25	H5139	2"	20	H5157	2-1/2	-
H5121	2-1/4	25	H5140	2-1/4	20	-	2-3/4	-
H5122	2-1/2	25	H5141	2-1/2	20	H5159	3"	-
H5123	2-3/4	25	H5142	2-3/4	20	H51595	3-1/4	-
H5124	3"	25	H5143	3"	20	H5160	3-1/2	-
H51245	3-1/4	25	H51435	3-1/4	20	H5161	4"	-
H5125	3-1/2	25	H5144	3-1/2	20	H5162	4-1/2	-
H5126	4"	25	H51445	3-3/4	20	H5163	5"	-
H5127	4-1/2	25	H5145	4"	20	H5164	5-1/2	-
H5128	5"	25	H51455	4-1/4	15	H5165	6"	-
H5129	5-1/2	20	H5146	4-1/2	15	H5166	6-1/2	-
H5130	6"	20	-	4-3/4	-	H5167	7"	-
H5131	6-1/2	-	H5147	5"	15	H5168	7-1/2	-
H5132	7"	-	H5148	5-1/2	15	H5169	8"	-
H5133	7-1/2	-	H5149	6"	10	H5170	9"	-
H5134	8"	-	H5150	6-1/2	-	-	10"	-
H51341	8-1/2	-	H5151	7"	-	-	11"	-
H51342	9"	-	H5152	7-1/2	-	-	12"	-
H51344	10"	-	H5153	8"	-	<b>1-1/4-7 NATIONAL COARSE</b>		
H51345	11"	-	H5154	9"	-	H51911	2-1/2	-
H51346	12"	-	H5155	10"	-	H5192	3"	-
H513467	15"	-	H51552	11"	-	H5193	3-1/2	-
			H51554	12"	-	H5194	4"	-
			H51555	13"	-	H51945	4-1/2	-
			H51556	14"	-	H5195	5"	-
			H51557	15"	-	H5196	5-1/2	-
						H5197	6"	-
						H5198	6-1/2	-
						H5199	7"	-
						H5200	7-1/2	-
						H5201	8"	-
						H52011	8-1/2	-
						H52012	9"	-
						H52014	10"	-
						H52017	13"	-
						H52018	14"	-
						<b>1-1/2-6 NATIONAL COARSE</b>		
						H5202	3"	-
						-	3-1/2	-
						H5203	4"	-
						H52035	4-1/2	-
						H5204	5"	-
						H52045	5-1/2	-
						H5205	6"	-
						-	6-1/2	-
						H5206	7"	-
						H5208	8"	-
						H5209	9"	-
						H5212	10"	-
						H5214	11"	-
						H5216	12"	-
STOCK NO.	LENGTH	BOX QTY.	STOCK NO.	LENGTH	BOX QTY.	STOCK NO.	LENGTH	BOX QTY.
<b>1"-8 NATIONAL COARSE</b>			<b>1-1/8-7 NATIONAL COARSE</b>					
H51708	1-1/2	-	-	2-1/2	-			
H5171	2"	-	H5184	3"	-			
-	2-1/4	-	H5185	3-1/2	-			
H5172	2-1/2	-	H5186	4"	-			
H51725	2-3/4	-	H5187	4-1/2	-			
H5173	3"	-	H5188	5"	-			
H51735	3-1/4	-	H5189	5-1/2	-			
H5174	3-1/2	-	H5190	6"	-			
H51745	3-3/4	-	H519005	7"	-			
H5175	4"	-	-	8"	-			
H5176	4-1/2	-	-	9"	-			
H5177	5"	-	-	10"	-			
H5178	5-1/2	-	-	11"	-			
H5179	6"	-	H5191	12"	-			
H51795	6-1/2	-						
H5180	7"	-						
H51805	7-1/2	-						
H5181	8"	-						
-	8-1/2	-						
H5182	9"	-						
H5183	10"	-						
-	11"	-						
H51834	12"	-						



**GRADE 5 HI CARBON  
HEX HEAD CAP SCREWS**  
NATIONAL FINE (SAE)



STOCK NO.	LENGTH	BOX QTY.	STOCK NO.	LENGTH	BOX QTY.	STOCK NO.	LENGTH	BOX QTY.
<b>1/4-28 NATIONAL FINE</b>			<b>5/16-24 NATIONAL FINE</b>			<b>3/8-24 NATIONAL FINE</b>		
H5500	1/2	100	H5518	1/2	100	H5536	1/2	100
-	5/8	-	-	5/8	-	H5537	5/8	100
H5501	3/4	100	H5519	3/4	100	H5538	3/4	100
-	7/8	100	H5520	1"	100	H5539	7/8	100
H5503	1"	100	H5521	1-1/4	100	H5540	1"	100
H5504	1-1/4	100	H5522	1-1/2	100	H5541	1-1/4	100
H5505	1-1/2	100	H5523	1-3/4	100	H5542	1-1/2	100
H5506	1-3/4	100	H5524	2"	100	H5543	1-3/4	100
H5507	2"	100	H5525	2-1/4	100	H5544	2"	100
H5508	2-1/4	100	H5526	2-1/2	100	H5545	2-1/4	100
H5509	2-1/2	100	H5527	2-3/4	100	H5546	2-1/2	100
H5510	2-3/4	100	H5528	3"	100	H5547	2-3/4	100
H5511	3"	100	-	3-1/4	-	H5548	3"	100
H5512	3-1/2	100	H5529	3-1/2	50	-	3-1/4	-
H5513	4"	100	H5530	4"	50	H5549	3-1/2	50
-	4-1/2	-	H5531	4-1/2	50	H5550	3-3/4	50
-	5"	-	H5532	5"	50	H5551	4"	50
-	5-1/2	-	-	5-1/2	-	H5552	4-1/2	50
-	6"	-	-	6"	-	H5553	5"	50
						H5554	5-1/2	50
						H5555	6"	50

STOCK NO.	LENGTH	BOX QTY.	STOCK NO.	LENGTH	BOX QTY.	STOCK NO.	LENGTH	BOX QTY.
<b>7/16-20 NATIONAL FINE</b>			<b>1/2-20 NATIONAL FINE</b>			<b>9/16-18 NATIONAL FINE</b>		
H5556	3/4	100	H5571	3/4	50	H5593	1"	25
H5557	1"	100	H5572	7/8	50	H5594	1-1/4	25
H5558	1-1/4	50	H5573	1"	50	H5595	1-1/2	25
H5559	1-1/2	50	H5574	1-1/4	50	H5596	1-3/4	25
H5560	1-3/4	50	H5575	1-1/2	50	H5597	2"	25
H5561	2"	50	H5576	1-3/4	50	H5598	2-1/4	25
H5562	2-1/4	50	H5577	2"	50	H5599	2-1/2	25
H5563	2-1/2	50	H5578	2-1/4	50	-	2-3/4	-
H55635	2-3/4	50	H5579	2-1/2	50	H5600	3"	25
H5564	3"	50	H5580	2-3/4	50	H5601	3-1/2	25
H5565	3-1/2	25	H5581	3"	50	H5602	4"	25
H5566	4"	25	H5582	3-1/4	25	H56021	4-1/2	25
H5567	4-1/2	25	H5583	3-1/2	25	-	5"	-
H5568	5"	25	H5584	4"	25	-	6"	-
-	5-1/2	-	H5585	4-1/2	25			
H5570	6"	25	H5586	5"	25			
			H5587	5-1/2	25			
			H5588	6"	25			
			H5589	6-1/2	-			
			H5590	7"	-			
			H5591	7-1/2	-			
			-	8"	-			

**ADDITIONAL SIZES  
AVAILABLE PER REQUEST**



**GRADE 5 HI CARBON  
HEX HEAD CAP SCREWS  
NATIONAL FINE (SAE)**



STOCK NO.	LENGTH	BOX QTY.	STOCK NO.	LENGTH	BOX QTY.	STOCK NO.	LENGTH	BOX QTY.
<b>5/8-18 NATIONAL FINE</b>			<b>3/4-16 NATIONAL FINE</b>			<b>7/8-14 NATIONAL FINE</b>		
H5603	1"	25	H5622	1-1/2	20	-	2"	-
H5604	1-1/4	25	H5629	1-3/4	20	H5636	2-1/2	15
H5605	1-1/2	25	H5624	2"	20	H5637	3"	15
H5606	1-3/4	25	H5625	2-1/4	20	H5638	3-1/2	15
H5607	2"	25	H5626	2-1/2	20	H5639	4"	15
H5608	2-1/4	25	-	2-3/4	-	H5640	4-1/2	15
H5609	2-1/2	25	H5627	3"	20	H5641	5"	15
H5610	2-3/4	25	H5628	3-1/2	20	H5642	5-1/2	15
H5611	3"	25	H5629	3-3/4	20	H5643	6"	15
-	3-1/4	-	H5630	4"	20	H5644	6-1/2	-
H5612	3-1/2	25	H5631	4-1/2	20	H5645	7"	-
H56125	3-3/4	25	H5632	5"	20	H5646	8"	-
H5613	4"	25	H5633	5-1/2	20			
H5614	4-1/2	25	H5634	6"	20			
H5615	5"	25	H5635	6-1/2	-			
H5616	5-1/2	25	H56352	7"	-			
H5617	6"	25	-	7-1/2	-			
H5618	6-1/2	-	H56354	8"	-			
H5619	7"	-						
H5620	7-1/2	-						
H5621	8"	-						

STOCK NO.	LENGTH	BOX QTY.	STOCK NO.	LENGTH	BOX QTY.	STOCK NO.	LENGTH	BOX QTY.
<b>1"-14 NATIONAL FINE</b>			<b>1-1/8-12 NATIONAL FINE</b>			<b>1-1/4-12 NATIONAL FINE</b>		
H5647	2"	10						
-	2-1/4	-						
H5648	2-1/2	10						
H5649	3"	10						
-	3-1/2	-						
H5651	4"	10						
-	5"	-						
-	6"	-						
-	7"	-						
-	8"	-						
H5661	9"	-						
H5662	10"	-						
			<b>AVAILABLE UPON REQUEST</b>					

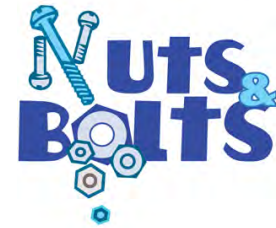

# LET OUR INVENTORY SERVE AS YOUR INVENTORY







**GRADE 8 HI CARBON  
HEX HEAD CAP SCREWS**  
NATIONAL COARSE (USS)



STOCK NO.	LENGTH	BOX QTY.	STOCK NO.	LENGTH	BOX QTY.	STOCK NO.	LENGTH	BOX QTY.
<b>1/4-20 NATIONAL COARSE</b>			<b>5/16-18 NATIONAL COARSE</b>			<b>3/8-16 NATIONAL COARSE</b>		
H8001	1/2	100	H8012	1/2	100	H80268	1/2	100
H80015	5/8	100	H80125	5/8	100	H80269	5/8	100
H8002	3/4	100	H8013	3/4	100	H8027	3/4	100
H80025	7/8	100	H8014	1"	100	H80275	7/8	100
H8003	1"	100	H8015	1-1/4	100	H8028	1"	100
H8004	1-1/4	100	H8016	1-1/2	100	H8029	1-1/4	100
H8005	1-1/2	100	H8017	1-3/4	100	H8030	1-1/2	100
H8006	1-3/4	100	H8018	2"	100	H8031	1-3/4	50
H8007	2"	100	H8019	2-1/4	100	H8032	2"	50
H80075	2-1/4	100	H8020	2-1/2	50	H8033	2-1/4	50
H8008	2-1/2	100	H8021	2-3/4	50	H8034	2-1/2	50
H80085	2-3/4	100	H8022	3"	50	H8035	2-3/4	50
H8009	3"	100	H80225	3-1/4	50	H8036	3"	50
H80095	3-1/4	50	H8023	3-1/2	50	H80365	3-1/4	50
H8010	3-1/2	50	H8024	4"	50	H8037	3-1/2	25
H8011	4"	50	H8025	4-1/2	50	H80378	3-3/4	25
H80111	4-1/2	50	H8026	5"	50	H8038	4"	25
H80112	5"	50	H80261	5-1/2	50	H80381	4-1/2	25
H80114	6"	50	H80262	6"	50	H80382	5"	25
						H80383	5-1/2	25
						H80384	6"	25
						H80386	7"	25
						H80388	8"	25

STOCK NO.	LENGTH	BOX QTY.	STOCK NO.	LENGTH	BOX QTY.	STOCK NO.	LENGTH	BOX QTY.
<b>7/16-14 NATIONAL COARSE</b>			<b>1/2-13 NATIONAL COARSE</b>			<b>9/16-12 NATIONAL COARSE</b>		
H8039	3/4	100	H80478	3/4	50	H80628	1"	25
H8040	1"	100	H8048	1"	50	H80629	1-1/4	25
H8041	1-1/4	50	H8049	1-1/4	50	H80630	1-1/2	25
H8042	1-1/2	50	H8050	1-1/2	50	H80631	1-3/4	25
H8043	1-3/4	50	H8051	1-3/4	50	H80632	2"	25
H8044	2"	50	H8052	2"	50	H80633	2-1/4	25
H80445	2-1/4	50	H8053	2-1/4	25	H80634	2-1/2	25
H8045	2-1/2	50	H8054	2-1/2	25	H80635	2-3/4	25
H80455	2-3/4	50	H80545	2-3/4	25	H806351	3"	25
H8046	3"	25	H8055	3"	25	H806352	3-1/4	25
H80465	3-1/2	25	H80555	3-1/4	25	H806353	3-1/2	25
H8047	4"	25	H8056	3-1/2	25	H806355	4"	25
H80471	4-1/2	25	H80565	3-3/4	25	H806359	4-1/2	25
H80472	5"	25	H8057	4"	25	H806361	5"	25
H80473	5-1/2	25	H8058	4-1/2	25	H806364	6"	25
H80474	6"	25	H8059	5"	25			
			H80595	5-1/2	25			
			H8060	6"	25			
			H8061	6-1/2	-			
			H8062	7"	-			
			H80621	7-1/2	-			
			H80622	8"	-			

ADDITIONAL SIZES AVAILABLE UPON REQUEST



**GRADE 8 HI CARBON  
HEX HEAD CAP SCREWS**  
NATIONAL COARSE (USS)



STOCK NO.	LENGTH	BOX QTY.	STOCK NO.	LENGTH	BOX QTY.	STOCK NO.	LENGTH	BOX QTY.
<b>5/8-11 NATIONAL COARSE</b>			<b>3/4-10 NATIONAL COARSE</b>			<b>7/8-9 NATIONAL COARSE</b>		
H8065	1"	25	H807988	1"	25	H808969	2"	-
H8066	1-1/4	25	H807989	1-1/4	25	H80897	2-1/4	-
H8067	1-1/2	25	H80799	1-1/2	25	H80898	2-1/2	-
H8068	1-3/4	25	H8080	1-3/4	25	H80899	2-3/4	-
H8069	2"	25	H8081	2"	25	H8090	3"	-
H8070	2-1/4	25	H80815	2-1/4	25	H80901	3-1/2	-
H8071	2-1/2	25	H8082	2-1/2	25	H80902	4"	-
H80715	2-3/4	25	H8083	2-3/4	25	H809021	4-1/2	-
H8072	3"	25	H8084	3"	25	H809022	5"	-
H80725	3-1/4	25	H80845	3-1/4	25	H809023	5-1/2	-
H8073	3-1/2	25	H8085	3-1/2	25	H809024	6"	-
H80735	3-3/4	25	H8086	4"	25	H809025	6-1/2	-
H8074	4"	25	H8087	4-1/2	25	H809026	7"	-
H8075	4-1/2	25	H8088	5"	25	-	7-1/2	-
H8076	5"	25	H80885	5-1/2	25	H809028	8"	-
H80761	5-1/2	25	H8089	6"	25	H809031	9"	-
H8077	6"	25	H80891	6-1/2	-	H809033	10"	-
H80775	6-1/2	-	H80892	7"	-	-	11"	-
H8078	7"	-	H80893	7-1/2	-	H809035	12"	-
H80785	7-1/2	-	H80894	8"	-			
H8079	8"	-	H808945	8-1/2	-			
H80791	8-1/2	-	H80895	9"	-			
H80792	9"	-	H80896	10"	-			
H80793	9-1/2	-	H808966	11"	-			
H80794	10"	-	H808967	12"	-			
H80795	11"	-	H808968	13"	-			
H80796	12"	-						
H807981	15"	-						

STOCK NO.	LENGTH	BOX QTY.	STOCK NO.	LENGTH	BOX QTY.	STOCK NO.	LENGTH	BOX QTY.
<b>1"-8 NATIONAL COARSE</b>			<b>1-1/8-7 NATIONAL COARSE</b>			<b>1-1/2-6 NATIONAL COARSE</b>		
H809047	1-1/2	-	-	3"	-	-	3"	-
H809049	2"	-	H809082	3-1/2	-	H809256	3-1/2	-
H809050	2-1/4	-	-	4"	-	H809258	4"	-
H809051	2-1/2	-	-	5"	-	H809260	4-1/2	-
H809052	2-3/4	-	-	6"	-	H809261	5"	-
H809053	3"	-	H809089	7"	-	-	5-1/2	-
H809054	3-1/4	-	H809091	8"	-	H809264	6"	-
H809055	3-1/2	-	H809092	9"	-	H809266	7"	-
H809056	4"	-				H809268	8"	-
H809057	4-1/2	-	<b>1-1/4-7 NATIONAL COARSE</b>			H809270	9"	-
H809058	5"	-	H809116	3"	-	H809271	10"	-
H809059	5-1/2	-	H809118	3-1/2	-			
H809060	6"	-	H809119	4"	-			
H809061	6-1/2	-	H809120	4-1/2	-			
H809062	7"	-	H809121	5"	-			
H809063	7-1/2	-	H809125	5-1/2	-			
H809064	8"	-	H809127	6"	-			
H809065	8-1/2	-	H809131	7"	-			
H809066	9"	-	H809135	8"	-			
H809068	10"	-	H809137	8-1/2	-			
H809069	11"	-	H809139	9"	-			
H809070	12"	-	H809143	10"	-			
H809072	14"	-	H8091442	11"	-			



**ADDITIONAL SIZES AVAILABLE UPON REQUEST**



**GRADE 8 HI CARBON  
HEX HEAD CAP SCREWS**  
NATIONAL FINE (SAE)



STOCK NO.	LENGTH	BOX QTY.	STOCK NO.	LENGTH	BOX QTY.	STOCK NO.	LENGTH	BOX QTY.
<b>1/4-28 NATIONAL FINE</b>			<b>5/16-24 NATIONAL FINE</b>			<b>3/8-24 NATIONAL FINE</b>		
H80929	1/2	100	H809468	1/2	100	H809598	1/2	100
H809295	5/8	100	H80947	3/4	100	H8096	3/4	100
H809298	3/4	100	H80948	1"	100	H8097	1"	100
H8093	1"	100	H80949	1-1/4	100	H8098	1-1/4	100
H80931	1-1/4	100	H8095	1-1/2	100	H8099	1-1/2	100
H8094	1-1/2	100	H80951	1-3/4	100	H80995	1-3/4	100
H809402	1-3/4	100	H80952	2"	100	H8100	2"	100
H80941	2"	100	H809525	2-1/4	100	H81005	2-1/4	100
H80942	2-1/4	100	H80953	2-1/2	100	H8101	2-1/2	100
H80943	2-1/2	100	H809535	2-3/4	100	H8102	2-3/4	100
H809435	2-3/4	100	H80954	3"	100	H8103	3"	100
H80944	3"	100	H80955	3-1/2	50	H81032	3-1/2	50
H80945	3-1/2	50	H80956	4"	50	H81034	4"	50
H809451	4"	50	H80958	5"	50	H81036	5"	50
H809463	5-1/2	50				H81037	5-1/2	50
						H81038	6"	50

STOCK NO.	LENGTH	BOX QTY.	STOCK NO.	LENGTH	BOX QTY.	STOCK NO.	LENGTH	BOX QTY.
<b>7/16-20 NATIONAL FINE</b>			<b>1/2-20 NATIONAL FINE</b>			<b>9/16-18 NATIONAL FINE</b>		
H8104	1"	100	H81069	1"	50	H81151	1-1/2	-
H8105	1-1/4	50	H8107	1-1/4	50	H811515	1-3/4	-
H8106	1-1/2	50	H8108	1-1/2	50	H81152	2"	-
H81061	1-3/4	50	H81085	1-3/4	50	H811525	2-1/4	-
H81062	2"	50	H8109	2"	50	H81153	2-1/2	-
H81063	2-1/4	50	H8110	2-1/4	50	H81154	3"	-
H81064	2-1/2	50	H8111	2-1/2	50	H8115405	3-1/2	-
H81065	2-3/4	50	H81115	2-3/4	25	H811541	4"	-
H81066	3"	50	H8112	3"	25	H811542	4-1/2	-
H810665	3-1/4	25	H81125	3-1/2	25	H81155	5"	-
H81067	3-1/2	25	H8114	4"	25	H81156	5-1/2	-
H81068	4"	25	H81144	4-1/2	25	H81157	6"	-
H810682	4-1/2	25	H81145	5"	25			
H810683	5"	25	H81146	5-1/2	25			
H810684	5-1/2	25	H81147	6"	25			
H810685	6"	25	H81148	6-1/2	20			
			H8115	7"	-			
			H811502	8"	-			

ADDITIONAL SIZES AVAILABLE UPON REQUEST



**GRADE 8 HI CARBON  
HEX HEAD CAP SCREWS**  
NATIONAL FINE (SAE)



STOCK NO.	LENGTH	BOX QTY.	STOCK NO.	LENGTH	BOX QTY.	STOCK NO.	LENGTH	BOX QTY.
<b>5/8-18 NATIONAL FINE</b>			<b>3/4-16 NATIONAL FINE</b>			<b>7/8-14 NATIONAL FINE</b>		
H81158	1"	25	H81265	1-1/2	25	-	1-1/2	-
H81159	1-1/4	25	H81266	1-3/4	25	H8141	2"	-
H8116	1-1/2	25	H81267	2"	25	H8142	2-1/2	-
H8117	1-3/4	25	H81268	2-1/4	25	H8143	3"	-
H8118	2"	25	H8127	2-1/2	25	H8144	3-1/2	-
H8119	2-1/4	25	H8128	2-3/4	25	H8145	4"	-
H8120	2-1/2	25	H8129	3"	20	H8146	4-1/2	-
H81205	2-3/4	25	H8131	3-1/2	15	H8147	5"	-
H8121	3"	25	H8132	4"	15	H81475	5-1/2	-
H81215	3-1/4	25	H8133	4-1/2	15	H8148	6"	-
H8122	3-1/2	25	H8134	5"	10			
H8123	4"	25	H81345	5-1/2	10			
H81232	4-1/2	25	H8135	6"	10			
H8124	5"	25	H8137	7"	-			
H8125	5-1/2	25	H81372	8"	-			
H81251	6"	25						
H81252	6-1/2	-						
H81255	7"	-						
H81257	7-1/2"	-						
H8126	8"	-						

STOCK NO.	LENGTH	BOX QTY.	STOCK NO.	LENGTH	BOX QTY.	STOCK NO.	LENGTH	BOX QTY.
<b>1"-14 NATIONAL FINE</b>			<b>1-1/8-12 NATIONAL FINE</b>			<b>1-1/4-12 NATIONAL FINE</b>		
H8150	2"	-						
H8151	2-1/2	-						
H8152	3"	-						
H8153	3-1/2	-						
H8154	4"	-						
H8155	4-1/2	-						
H8156	5"	-						
H8157	5-1/2	-						
H8158	6"	-						
H8159	6-1/2	-						
			<b>AVAILABLE UPON REQUEST</b>			<b>AVAILABLE UPON REQUEST</b>		



STOCK NO.	LENGTH	BOX QTY.
<b>1-1/2-12 NATIONAL FINE</b>		
<b>AVAILABLE UPON REQUEST</b>		



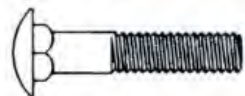

**CARRIAGE BOLTS**  
ROUND HEAD - SQUARE NECK

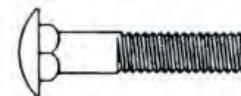

STOCK NO.	LENGTH	BOX QTY.	STOCK NO.	LENGTH	BOX QTY.	STOCK NO.	LENGTH	BOX QTY.
<b>(3/16) 10-24 NATIONAL COARSE</b>			<b>1/4-20 NATIONAL COARSE</b>			<b>5/16-18 NATIONAL COARSE</b>		
-	1/2	-	CB0379	1/2	100	CB168	3/4	100
CB01	3/4	100	CB038	5/8	100	CB17	1"	100
CB02	1"	100	CB039	3/4	100	CB18	1-1/4	100
CB025	1-1/4	100	CB04	1"	100	CB19	1-1/2	100
CB03	1-1/2	100	CB05	1-1/4	100	CB20	1-3/4	100
-	1-3/4	-	CB06	1-1/2	100	CB21	2"	100
CB035	2"	100	CB07	1-3/4	100	CB22	2-1/4	100
-	2-1/4	-	CB08	2"	100	CB23	2-1/2	100
-	2-1/2	-	CB085	2-1/4	100	-	2-3/4	-
-	3"	-	CB09	2-1/2	100	CB24	3"	50
			-	2-3/4	-	CB25	3-1/2	50
			CB10	3"	100	CB255	3-3/4	50
			-	3-1/4	-	CB26	4"	50
			CB11	3-1/2	50	CB27	4-1/2	50
			CB115	3-3/4	50	CB28	5"	50
			CB12	4"	50	-	5-1/2	-
			CB13	4-1/2	50	CB282	6"	50
			CB14	5"	50	CB283	7"	50
			CB145	5-1/2	50	-	8"	-
			CB15	6"	50	-	9"	-
			CB16	7"	50	CB286	10"	-
			-	8"	-			



STOCK NO.	LENGTH	BOX QTY.	STOCK NO.	LENGTH	BOX QTY.	STOCK NO.	LENGTH	BOX QTY.
<b>3/8-16 NATIONAL COARSE</b>			<b>7/16-14 NATIONAL COARSE</b>			<b>5/8-11 NATIONAL COARSE</b>		
CB288	3/4	100	CB501	1-1/4	50	CB65	1-1/2	25
CB29	1"	100	<b>AVAILABLE TO 8" - PER REQUEST</b>			-	1-3/4	-
CB30	1-1/4	100				CB66	2"	25
CB31	1-1/2	100	<b>1/2-13 NATIONAL COARSE</b>			CB67	2-1/2	25
CB32	1-3/4	100	CB503	1"	50	CB68	3"	25
CB33	2"	50	CB505	1-1/2	50	CB69	4"	25
CB34	2-1/4	50	CB51	2"	25	CB695	4-1/2	25
CB35	2-1/2	50	CB53	2-1/2	25	CB70	5"	25
CB36	2-3/4	50	CB54	3"	25	CB71	6"	25
CB37	3"	50	CB55	3-1/2	25	-	7"	-
CB38	3-1/4	50	CB56	4"	25	-	8"	-
CB39	3-1/2	25	CB57	4-1/2	25	-	9"	-
CB40	4"	25	CB58	5"	25	-	10"	-
CB41	4-1/2	25	CB59	5-1/2	25	<b>3/4-10 NATIONAL COARSE</b>		
CB42	5"	25	CB60	6"	25	CB72	2"	-
CB43	5-1/2	25	CB61	7"	25	-	3"	-
CB44	6"	25	CB62	8"	25	CB76	4"	-
CB45	6-1/2	25	CB625	9"	25	-	5"	-
CB46	7"	25	CB63	10"	15	CB80	6"	-
CB47	7-1/2	25	-	11"	-			
CB48	8"	25	CB64	12"	15			
CB49	9"	25						
CB495	10"	25						
CB50	12"	25						

ADDITIONAL SIZES AVAILABLE UPON REQUEST

### STRUCTURAL BOLTS



A-325 STRUCTURAL BOLTS - PLAIN  
NUTS MUST BE ORDERED SEPARATELY

STOCK NO.	SIZE	BOX QTY.
STB04	1/2-13 x 1-1/4	-
STB041	1/2-13 x 1-1/2	-
STB042	1/2-13 x 1-3/4	-
STB043	1/2-13 x 2"	-
STB044	1/2-13 x 2-1/4	-
STB045	1/2-13 x 2-1/2	-
STB046	1/2-13 x 2-3/4	-
STB047	1/2-13 x 3"	-
STB048	1/2-13 x 3-1/4	-
-	1/2-13 x 3-1/2	-
STB07	1/2-13 x 7"	-
STB08	5/8-11 x 1-1/2	-
STB09	5/8-11 x 1-3/4	-
STB10	5/8-11 x 2"	-
STB11	5/8-11 x 2-1/4	-
STB111	5/8-11 x 2-1/2	-
STB112	5/8-11 x 2-3/4	-
STB113	5/8-11 x 3"	-
STB114	5/8-11 x 3-1/4	-
STB115	5/8-11 x 3-1/2	-
STB116	5/8-11 x 3-3/4	-
STB117	5/8-11 x 4"	-
STB119	5/8-11 x 4-1/2	-
STB15	3/4-10 x 1-1/2	-
STB16	3/4-10 x 1-3/4	-
STB17	3/4-10 x 2"	-
STB18	3/4-10 x 2-1/4	-
STB19	3/4-10 x 2-1/2	-
STB20	3/4-10 x 2-3/4	-
STB21	3/4-10 x 3"	-
STB22	3/4-10 x 3-1/4	-
STB23	3/4-10 x 3-1/2	-
STB231	3/4-10 x 3-3/4	-
STB232	3/4-10 x 4"	-
STB233	3/4-10 x 4-1/4	-
STB234	3/4-10 x 4-1/2	-
STB235	3/4-10 x 4-3/4	-
STB236	3/4-10 x 5"	-
-	3/4-10 x 5-1/4	-
STB238	3/4-10 x 5-1/2	-
STB240	3/4-10 x 6"	-

**WE ARE  
YOUR  
ONE-STOP  
SOURCE FOR  
INDUSTRIAL  
SUPPLIES**

A-325 STRUCTURAL BOLTS - PLAIN  
NUTS MUST BE ORDERED SEPARATELY  
(CONTINUED)

STOCK NO.	SIZE	BOX QTY.
STB26	7/8-9 x 2"	-
STB27	7/8-9 x 2-1/4	-
STB28	7/8-9 x 2-1/2	-
STB29	7/8-9 x 2-3/4	-
STB30	7/8-9 x 3"	-
STB305	7/8-9 x 3-1/4	-
STB31	7/8-9 x 3-1/2	-
STB315	7/8-9 x 3-3/4	-
STB32	7/8-9 x 4"	-
STB325	7/8-9 x 4-1/4	-
STB33	7/8-9 x 4-1/2	-
STB34	7/8-9 x 4-3/4	-
STB35	7/8-9 x 5"	-
STB352	7/8-9 x 5-1/2	-
STB354	7/8-9 x 6"	-
STB39	1"-8 x 2-1/4	-
STB40	1"-8 x 2-1/2	-
STB41	1"-8 x 2-3/4	-
STB42	1"-8 x 3"	-
STB43	1"-8 x 3-1/4	-
STB435	1"-8 x 3-1/2	-
STB44	1"-8 x 3-3/4	-
STB45	1"-8 x 4"	-
STB46	1"-8 x 4-1/4	-
STB47	1"-8 x 4-1/2	-
STB48	1"-8 x 4-3/4	-
STB481	1"-8 x 5"	-
STB483	1"-8 x 5-1/2	-
STB493	1"-8 x 6"	-
STB495	1"-8 x 6-1/2	-
STB73	1-1/4-7 x 3-1/4	-
STB87	1-1/4-7 x 8"	-

**ADDITIONAL SIZES AVAILABLE  
UPON REQUEST**

TWO EXECUTIVES IN EXPENSIVE SUITS STOPPED OFF AT A SMALL COUNTRY BAR. AS THE BARTENDER SERVED THEM, HE HEARD A MUFFLED *BEEP BEEP* SOUND AND WATCHED AS ONE OF THE MEN CALMLY REMOVED A PEN FROM HIS INSIDE COAT POCKET AND BEGAN CARRYING ON A CONVERSATION. WHEN HE WAS DONE TALKING, THE EXEC NOTICED THE BARTENDER AND OTHER CUSTOMERS GIVING HIM PUZZLED LOOKS. "I WAS JUST ANSWERING A CALL ON MY STATE-OF-THE-ART CELLULAR PEN," HE EXPLAINED.

A SHORT WHILE LATER ANOTHER ODD TONE WAS HEARD. THIS TIME THE SECOND EXECUTIVE PICKED UP HIS FANCY HAT, FIDDLED WITH THE LINING AND STARTED TALKING INTO IT. AFTER A FEW MINUTES HE PUT THE HAT BACK ON THE BAR. "THAT WAS JUST A CALL ON MY STATE-OF-THE-ART CELLULAR HAT," HE SAID MATTER-OF-FACTLY.

A FEW STOOLS DOWN ONE OF THE LOCALS SUDDENLY LET OUT A LOUD BURP. "QUICK!" HE EXCLAIMED. "ANYBODY GOT A PIECE OF PAPER? I HAVE A FAX COMIN' IN!"



A-325 STRUCTURAL BOLTS - GALVANIZED  
NUTS MUST BE ORDERED SEPARATELY

STOCK NO.	SIZE	BOX QTY.
STB9101	3/4-10 x 1-3/4	-
STB9102	3/4-10 x 2"	-
STB9103	3/4-10 x 2-1/4	-
STB9104	3/4-10 x 2-1/2	-
STB9105	3/4-10 x 2-3/4	-
STB9118	7/8-9 x 2"	-
STB9119	7/8-9 x 2-1/4	-
STB9121	7/8-9 x 2-3/4	-
STB9122	7/8-9 x 3"	-

**ADDITIONAL SIZES AVAILABLE  
UPON REQUEST**

**CALL  
IN  
YOUR  
ORDER  
FOR  
PROMPT,  
COURTEOUS  
ASSISTANCE**



**CALL US FOR ALL YOUR NEEDS  
855-785-TOOL**

**MISCELLANEOUS BOLTS**  
**(SHAKER-SCREEN, MACHINE, ELEVATOR AND PLOW)**

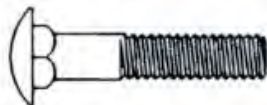

**GRADE 5 SHAKER-SCREEN (CARRIAGE) BOLTS**

STOCK NO.	SIZE	BOX QTY.
CB906	1/2-13 x 1-1/2	-
907	1/2-13 x 1-3/4	-
908	1/2-13 x 2"	-
910	1/2-13 x 2-1/2	-
CB912	1/2-13 x 3"	-
CB914	1/2-13 x 3-1/2	-
CB915	1/2-13 x 4"	-
916	1/2-13 x 4-1/2	-
917	1/2-13 x 5"	-
-	5/8-11 x 2-1/2	-
SSB50*	5/8-11 x 2-1/2	-
CB931	5/8-11 x 3"	-
933	5/8-11 x 3-1/2	-
CB934	5/8-11 x 4"	-
CB936	5/8-11 x 5"	-
-	3/4-10 x 2"	-
-	3/4-10 x 2-1/2	-
-	3/4-10 x 3"	-
CB949	3/4-10 x 3-1/2	-
CB950	3/4-10 x 4"	-
CB951	3/4-10 x 4-1/2	-
CB952	3/4-10 x 5"	-
953	3/4-10 x 5-1/2	-
CB954	3/4-10 x 6"	-

\*GRADE 8

**ELEVATOR BOLTS**

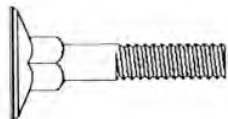

STOCK NO.	SIZE	BOX QTY.
EB12	1/4-20 x 1"	100
EB13	1/4-20 x 1-1/4	100
EB14	1/4-20 x 1-1/2	100
EB15	1/4-20 x 1-3/4	100
EB16	1/4-20 x 2"	100
-	1/4-20 x 2-1/2	-
EB18	1/4-20 x 3"	100
-	5/16-18 x 1"	-
EB23	5/16-18 x 1-1/2	-
EB24	5/16-18 x 2"	-
EB25	5/16-18 x 2-1/2	-
-	3/8-16 x 1-1/4	-
EB28	3/8-16 x 1-1/2	50
-	3/8-16 x 2"	-
EB31	3/8-16 x 3"	50

**MANY ADDITIONAL SIZES AVAILABLE  
UPON REQUEST**

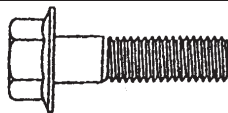

**GR. 8 HEX FLANGE BOLTS**

STOCK NO.	SIZE	BOX QTY.
HFB8094	1/2-13 x 1-1/2	50
HFB8095	1/3-13 x 1-3/4	50
HFB8096	1/2-13 x 2"	50
-	1/2-13 x 2-1/4	-
HFB8098	1/2-13 x 2-1/2	-
HFB8100	1/2-13 x 3"	50
HFB8122	5/8-11 x 1-1/4	25
-	5/8-11 x 1-1/2	-
HFB8124	5/8-11 x 1-3/4	25
HFB8125	5/8-11 x 2"	25
HFB8127	5/8-11 x 2-1/2	25
-	5/8-11 x 3"	-
HFB8155	3/4-10 x 2"	25
HFB8157	3/4-10 x 2-1/2	-
-	3/4-10 x 3"	-

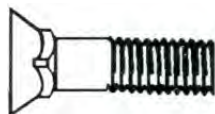

**PLOW BOLTS - PLAIN - GRADE 8**

STOCK NO.	SIZE	BOX QTY.
PLB58212	5/8-11 x 2-1/2	-
PLB58312	5/8-11 x 3-1/2	-
PLB342	3/4-10 x 2"	-
PLB34214	3/4-10 x 2-1/4	-
PLB34312	3/4-10 x 3-1/2	-
PLB34334	3/4-10 x 3-3/4	-
PLB783	7/8-9 x 3"	-
PLB1314	1"-8 x 3-1/4	-
PLB1334	1"-8 x 3-3/4	-
PLB1412	1"-8 x 4-1/2	-
PLB114418	1-1/4 x 4-1/8	-
PLB114412	1-1/4 x 4-1/2	-

THE ZOO BUILT A SPECIAL EIGHT-FOOT-HIGH ENCLOSURE FOR ITS NEWLY ACQUIRED KANGAROO, BUT THE NEXT MORNING THE ANIMAL WAS FOUND HOPPING AROUND OUTSIDE. THE HEIGHT OF THE FENCE WAS INCREASED TO 15 FEET, BUT THE KANGAROO GOT OUTSIDE AGAIN. EXASPERATED, THE ZOO DIRECTOR HAD THE HEIGHT INCREASED TO 30 FEET, BUT THE KANGAROO STILL ESCAPED. A GIRAFFE ASKED THE KANGAROO, "HOW HIGH DO YOU THINK THEY'LL BUILD THE FENCE?" "I DON'T KNOW," SAID THE KANGAROO. "MAYBE A THOUSAND FEET IF THEY KEEP LEAVING THE GATE UNLOCKED."

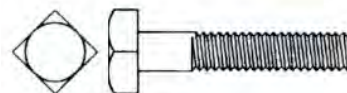

**MACHINE BOLTS - SQUARE HEAD  
PLAIN**

STOCK NO.	SIZE	BOX QTY.
-	1/4-20 x 1"	-
-	1/4-20 x 1-1/4	-
-	1/4-20 x 1-1/2	-
-	1/4-20 x 2"	-
-	1/4-20 x 2-1/2	-
-	1/4-20 x 3"	-
MB08	1/4-20 x 3-1/2	-
-	1/4-20 x 4"	-
MB11	5/16-18 x 1"	-
MB13	5/16-18 x 1-1/2	-
MB15	5/16-18 x 2"	-
MB21	3/8-16 x 1"	-
MB22	3/8-16 x 1-1/4	-
MB23	3/8-16 x 1-1/2	-
MB29	3/8-16 x 3"	-
MB31	1/2-13 x 1"	-
MB32	1/2-13 x 1-1/4	-
MB33	1/2-13 x 1-1/2	-
MB34	1/2-13 x 1-3/4	-
MB35	1/2-13 x 2"	-
MB36	1/2-13 x 2-1/2	-
MB37	1/2-13 x 3"	-
MB38	1/2-13 x 3-1/2	-
MB39	1/2-13 x 4"	-
MB40	1/2-13 x 4-1/2	-
MB41	1/2-13 x 5"	-
-	5/8-11 x 1-1/2	-
MB50	5/8-11 x 2"	-
MB52	5/8-11 x 2-1/2	-
MB53	5/8-11 x 3"	-
MB54	5/8-11 x 4"	-
MB55	5/8-11 x 5"	-
MB555	5/8-11 x 5-1/2	-
MB57	5/8-11 x 7"	-
MB62	3/4-10 x 2-1/2	-
MB63	3/4-10 x 3"	-
MB64	3/4-10 x 4"	-
MB642	3/4-10 x 4-1/2	-
MB643	3/4-10 x 5"	-

**YOUR  
ONE-STOP  
SOURCE FOR  
INDUSTRIAL  
SUPPLIES**

## STEEL FLAT WASHERS

### USS FLAT WASHERS

#### ZINC PLATED



STOCK NO.	SIZE	OUTSIDE DIA.	INSIDE DIA.	BOX QTY.
FW040	#10 (#12)	9/16	1/4	100
FW041	1/4	3/4	5/16	100
FW042	5/16	7/8	3/8	100
FW043	3/8	1"	7/16	100
FW044	7/16	1-1/4	1/2	100
FW045	1/2	1-3/8	9/16	100
FW046	9/16	1-1/2	5/8	50
FW047	5/8	1-3/4	11/16	50
FW048	3/4	2"	13/16	50
FW049	7/8	2-1/4	15/16	25
FW050	1"	2-1/2	1-1/16	25
FW051	1-1/8	2-3/4	1-1/4	25
FW052	1-1/4	3"	1-3/8	25
FW053	1-3/8	3-1/4	1-1/2	25
FW054	1-1/2	3-1/2	1-5/8	25
FW055	2"	4-1/2	2-1/8	-

#### USS PLAIN FINISH

STOCK NO.	SIZE	OUTSIDE DIA.	INSIDE DIA.	BOX QTY.
FW080	1/4	3/4	5/16	100
FW081	5/16	7/8	3/8	100
FW082	3/8	1"	7/16	100
FW083	7/16	1-1/4	1/2	100
FW084	1/2	1-3/8	9/16	100
-	9/16	1-1/2	5/8	-
FW086	5/8	1-3/4	11/16	50
FW087	3/4	2"	13/16	50
FW088	7/8	2-1/4	15/16	25
FW089	1"	2-1/2	1-1/16	25
FW090	1-1/8	2-3/4	1-1/4	25
FW091	1-1/4	3"	1-3/8	25
FW092	1-1/2	3-1/2	1-5/8	25
FW0925	1-5/8	3-3/4	1-3/4	-
FW093	1-3/4	4"	1-7/8	-
-	1-7/8	4-1/2	2"	-
FW094	2"	4-1/2	2-1/8	-
FW095	2-1/4	4-3/4	2-3/8	-
FW096	2-1/2	5"	2-5/8	-
FW097	2-3/4	5-1/4	2-7/8	-
FW098	3"	5-1/2	3-1/8	-

### GALVANIZED FLAT WASHERS

STOCK NO.	SIZE	OUTSIDE DIA.	INSIDE DIA.	BOX QTY.
FW217	3/8	1"	7/16	-
FW219	1/2	1-3/8	9/16	-
FW222	3/4	2"	13/16	-

### FINISHING WASHERS NICKEL PLATED



STOCK NO.	SIZE	BOX QTY.
FW126	#6	100
FW127	#8	100
FW128	#10	100
FW129	#12	100
FW130	#14	100

### SAE FLAT WASHERS

#### ZINC PLATED



STOCK NO.	SIZE	OUTSIDE DIA.	INSIDE DIA.	BOX QTY.
FW0008	#4	5/16	1/8	100
FW0001	#6	3/8	5/32	100
FW0002	#8	7/16	3/16	100
FW0003	#10	1/2	7/32	100
FW0004	1/4	5/8	9/32	100
FW0005	5/16	11/16	11/32	100
FW0006	3/8	13/16	13/32	100
FW0007	7/16	59/64	15/32	100
FW0008	1/2	1-1/16	17/32	100
FW0009	9/16	1-3/16	19/32	100
FW0010	5/8	1-5/16	21/32	100
FW0011	3/4	1-1/2	13/16	50
FW0012	7/8	1-3/4	15/16	25
FW0013	1"	2"	1-1/16	25
FW0014	1-1/8	2-1/4	1-3/16	25
FW0015	1-1/4	2-1/2	1-5/16	25
-	1-3/8	2-3/4	1-7/16	-
FW0016	1-1/2	3"	1-9/16	25

### FENDER WASHERS

#### ZINC PLATED



STOCK NO.	SIZE	BOX QTY.
FW141	1/8 x 3/4	100
FW143	5/32 x 7/8	100
FW145	3/16 x 3/4	100
FW146	3/16 x 1"	100
FW147	3/16 x 1-1/4	100
FW149	1/4 x 1"	100
FW150	1/4 x 1-1/4	100
FW151	1/4 x 1-1/2	100
FW152	1/4 x 2"	100
FW153	5/16 x 1-1/4	100
-	5/16 x 1-1/2	100
FW156	3/8 x 1-1/4	100
FW157	3/8 x 1-1/2	100
FW158	3/8 x 2"	100
FW160	1/2 x 2"	100

### EXTRA HEAVY FENDER WASHERS

STOCK NO.	SIZE	BOX QTY.
FW161	3/16 x 1"	100
FW165	1/4 x 1-1/2	100
FW167	5/16 x 1-1/4	100
FW169	3/8 x 1-1/4	100
FW170	3/8 x 1-1/2	100

### STRUCTURAL (A325) FLAT WASHERS

#### HARDENED - PLAIN FINISH

STOCK NO.	SIZE	OUTSIDE DIA.	INSIDE DIA.	BOX QTY.
FW180	1/2	1-1/16	17/32	100
FW181	5/8	1-5/16	21/32	50
FW182	3/4	1-1/2	13/16	50
FW183	7/8	1-3/4	15/16	50
FW184	1"	2"	1-1/16	50
FW185	1-1/8	2-1/4	1-3/16	-
FW186	1-1/4	2-1/2	1-5/16	50
-	1-1/2	3"	1-9/16	-
-	2"	-	-	-

### GRADE 8 USS FLAT WASHERS

#### ZINC YELLOW



STOCK NO.	SIZE	OUTSIDE DIA.	INSIDE DIA.	BOX QTY.
FW265	1/4	3/4	5/16	100
FW266	5/16	7/8	3/8	100
FW267	3/8	1"	7/16	100
FW268	7/16	1-1/4	1/2	100
FW269	1/2	1-3/8	9/16	100
FW270	9/16	1-1/2	5/8	50
FW271	5/8	1-3/4	11/16	50
FW272	3/4	2"	13/16	50
FW273	7/8	2-1/4	15/16	25
FW274	1"	2-1/2	1-1/16	25
FW275	1-1/8	2-3/4	1-1/4	25
FW276	1-1/4	3"	1-3/8	25
FW277	1-1/2	3-1/2	1-5/8	25

### GRADE 8 SAE FLAT WASHERS

#### ZINC YELLOW

STOCK NO.	SIZE	OUTSIDE DIA.	INSIDE DIA.	BOX QTY.
FW176	1/4	5/8	9/32	100
FW177	5/16	11/16	11/32	100
FW178	3/8	13/16	13/32	100
FW179	7/16	59/64	15/32	100
FW1795	1/2	1-1/16	17/32	100
FW1796	9/16	1-3/16	19/32	100
FW1797	5/8	1-5/16	21/32	100
FW1798	3/4	1-1/2	13/16	50
FW17985	7/8	1-3/4	15/16	25
FW1799	1"	2"	1-1/16	25
-	1-1/8	2-1/4	1-3/16	-
FW17991	1-1/4	2-1/2	1-5/16	-
FW17993	1-1/2	3"	1-9/16	-
FW17994	1-3/4	3-3/8	1-7/8	-
FW17995	2"	3-3/4	2-1/8	-

### EXTRA-THICK HARDENED FLAT WASHERS

#### ZINC PLATED



STOCK NO.	SIZE	OUTSIDE DIA.	INSIDE DIA.	BOX QTY.
FW230	3/16	1/2	13/64	100
FW231	1/4	5/8	9/32	100
FW232	5/16	11/16	11/32	100
FW233	3/8	13/16	13/32	100
FW2335	7/16	59/64	15/32	100
FW234	1/2	1-1/16	17/32	100
-	9/16	1-3/16	19/32	-
FW236	5/8	1-5/16	21/32	100
FW237	3/4	1-1/2	13/16	50
FW238	7/8	1-3/4	15/16	25
FW239	1"	2"	1-1/16	25
FW240	1-1/8	2-1/4	1-1/8	25
FW241	1-1/4	2-1/2	1-3/8	25
FW242	1-1/2	3"	1-9/16	-

### STRUCTURAL (A325) FLAT WASHERS

#### HARDENED - GALVANIZED

STOCK NO.	SIZE	OUTSIDE DIA.	INSIDE DIA.	BOX QTY.
FW194	3/4	1-1/2	13/16	50
FW195	7/8	1-3/4	15/16	50



**LOCK WASHERS**

**SPLIT LOCK WASHERS**



STOCK NO.	SIZE	FINISH	BOX QTY.
-	#2	ZINC	-
-	#3	ZINC	-
LW01	#4	ZINC	100
LW02	#6	ZINC	100
LW03	#8	ZINC	100
LW04	#10	ZINC	100
LW05	#12	ZINC	100
LW06	1/4	ZINC	100
LW07	5/16	ZINC	100
LW08	3/8	ZINC	100
LW09	7/16	ZINC	100
LW10	1/2	ZINC	100
LW11	9/16	ZINC	100
LW12	5/8	ZINC	100
LW13	3/4	ZINC	100
LW14	7/8	PLAIN	50
LW141	7/8	ZINC	50
LW15	1"	PLAIN	-
LW151	1"	ZINC	-
LW16	1-1/8	PLAIN	-
LW17	1-1/4	PLAIN	-
LW175	1-3/8	PLAIN	-
LW18	1-1/2	PLAIN	-
LW185	1-3/4	PLAIN	-
LW19	2"	PLAIN	-
LW20	2-1/4	PLAIN	-
LW22	2-1/2	PLAIN	-
-	2-3/4	PLAIN	-
-	3"	PLAIN	-

**HI-COLLAR LOCK WASHERS\***



STOCK NO.	SIZE	FINISH	BOX QTY.
LW60	#10	PLAIN	100
LW61	1/4	PLAIN	100
LW62	5/16	PLAIN	100
LW63	3/8	PLAIN	100
LW635	7/16	PLAIN	100
LW64	1/2	PLAIN	100
-	9/16	PLAIN	-
LW65	5/8	PLAIN	50
LW66	3/4	PLAIN	50
LW67	7/8	PLAIN	25
LW68	1"	PLAIN	25
-	1-1/8	PLAIN	-
LW69	1-1/4	PLAIN	-
-	1-3/8	PLAIN	-
LW70	1-1/2	PLAIN	-
LW71	1-3/4	PLAIN	-
LW72	2"	PLAIN	-

\*FOR USE WITH SOCKET HEAD CAP SCREWS IN A COUNTERBORE APPLICATION

**INTERNAL / EXTERNAL LOCK WASHERS**



STOCK NO.	SIZE	FINISH	BOX QTY.
LW852	#10	ZINC	100
LW854	1/4	ZINC	100
LW856	3/8	ZINC	100

**GRADE 8 LOCK WASHERS**



STOCK NO.	SIZE	FINISH	BOX QTY.
LW75	1/4	ZINC YEL.	100
LW76	5/16	" "	100
LW77	3/8	" "	100
LW78	7/16	" "	100
LW79	1/2	" "	100
LW80	9/16	" "	50
LW81	5/8	" "	50
LW82	3/4	" "	50
LW83	7/8	" "	50
LW84	1"	" "	50
LW85	1-1/8	" "	25
LW8501	1-1/4	" "	25
LW8503	1-1/2	" "	25

**EXTERNAL TOOTH LOCK WASHERS**



STOCK NO.	SIZE	FINISH	BOX QTY.
LW25	#4	ZINC	100
-	#5	ZINC	-
LW26	#6	ZINC	100
LW27	#8	ZINC	100
LW28	#10	ZINC	100
LW29	#12	ZINC	100
LW30	1/4	ZINC	100
LW31	5/16	ZINC	100
LW32	3/8	ZINC	100
LW33	7/16	ZINC	100
LW34	1/2	ZINC	100
LW35	9/16	ZINC	100
LW36	5/8	ZINC	100
LW37	3/4	ZINC	100
-	7/8	ZINC	-
LW39	1"	ZINC	-

**INTERNAL TOOTH LOCK WASHERS**



STOCK NO.	SIZE	FINISH	BOX QTY.
LW43	#2	ZINC	100
LW45	#4	ZINC	100
LW46	#6	ZINC	100
LW47	#8	ZINC	100
LW48	#10	ZINC	100
LW49	#12	ZINC	100
LW50	1/4	ZINC	100
LW51	5/16	ZINC	100
LW52	3/8	ZINC	100
LW53	7/16	ZINC	100
LW54	1/2	ZINC	100
LW55	9/16	ZINC	100
LW56	5/8	ZINC	100
LW57	3/4	ZINC	100
LW58	7/8	ZINC	-
-	1"	ZINC	-

THIS IS A COMPREHENSIVE CATALOG OF OUR MAJOR LINES AND SERVICES, BUT IT DOES NOT SHOW ALL AVAILABLE PRODUCT LINES. IF THERE IS SOMETHING YOU NEED THAT IS NOT SHOWN, WE EITHER CARRY IT OR CAN GET IT. PLEASE CALL US FOR INFORMATION.



CALL US FOR ALL YOUR NEEDS  
**855-785-TOOL**



A LEADING AUTHORITY IS ANYONE WHO HAS GUESSED RIGHT MORE THAN ONCE.  
--FRANK A. CLARK

## SPECIALTY WASHERS

### BEVEL WASHERS

#### MALLEABLE

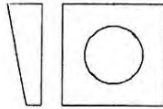

STOCK NO.	SIZE	FINISH	BOX QTY.
CHD11	5/16	PLAIN	100
CHD12	3/8	PLAIN	50
CHD13	1/2	PLAIN	50
CHD14	5/8	PLAIN	50
CHD15	3/4	PLAIN	50
CHD16	7/8	PLAIN	-
CHD17	1"	PLAIN	-

#### STRUCTURAL A-325

STOCK NO.	SIZE	FINISH	BOX QTY.
FW201	5/8	PLAIN	50
FW202	3/4	PLAIN	25

### BELLEVILLE WASHERS



BELLEVILLE (DISC SPRING) WASHERS ARE USED TO MAINTAIN LOAD OR TENSION IN BOLTED ASSEMBLIES. PRESSURE BEGINS AT THE OUTER RADIUS AND FLATTENS GRADUALLY TOWARD THE BOLT AS DEFLECTION PROGRESSES. BELLEVILLE WASHERS EXERT A UNIFORM PRESSURE THAT REMAIN LINEAR, DESPITE TENSION LOSSES CAUSED BY THERMAL EXPANSION AND CONTRACTION.

STOCK NO.	SIZE	FINISH	BOX QTY.
FW967	5/16	PLAIN	-
FW970	1/2	PLAIN	-
FW997	5/8	PLAIN	-
FW999	3/4	PLAIN	-

**CALL FOR  
COMPLETE  
SPECIFICATIONS  
AND PRICES**

### NORD-LOCK WASHERS

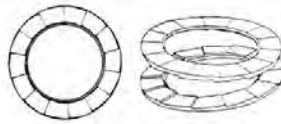

VIBRATION-PROOF LOCK WASHERS HAVE CAMS OR WEDGES ON ONE SIDE AND RADIAL TEETH OR RIBS ON THE OTHER. THE TWO WASHERS ARE INSTALLED CAM FACE TO CAM FACE, AND WHEN A NUT OR SCREW ATTEMPTS TO TURN LOOSE, THE MATING WASHER SLIDES UP THE CAMS OF THE OTHER. THUS, BOLT TENSION IS MAINTAINED. SOLD AS A PAIR. ZINC-PLATED.

#### FRACTIONAL

STOCK NO.	SIZE
NLW01	#6 (M3.5)
NLW02	#8 (M4)
NLW03	#10 (M5)
NLW04	1/4"
NLW05	5/16" (M8)
NLW06	3/8"
07	7/16" (M11)
NLW08	1/2"
09	9/16" (M14)
NLW10	5/8" (M16)
NLW11	3/4"
12	7/8" (M22)
13	1"
NLW14	1-1/8" (M30)
15	1-1/4" (M33)
16	1-3/8" (M36)
17	1-1/2" (M39)
18	1-3/4" (M45)
19	2" (M52)

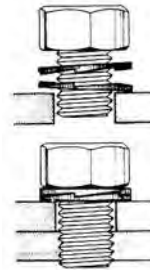

(CONTINUED NEXT COLUMN)

### NORD-LOCK WASHERS

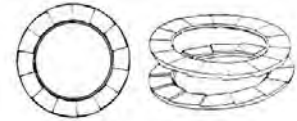

STOCK NO.      SIZE

#### METRIC

STOCK NO.      SIZE

NLWM03	M3 (#5)
NLWM04	M4 (#8)
NLWM05	M5 (#10)
NLWM06	M6
NLWM08	M8 (5/16")
NLWM10	M10
NLWM11	M11 (7/16")
NLWM12	M12
NLWM14	M14 (9/16")
NLWM16	M16 (5/8")
M18	M18
NLWM20	M20
NLWM22	M22 (7/8")
M24	M24
M27	M27
NLWM30	M30 (1-1/8")
NLWM33	M33 (1-1/4")
NLWM36	M36 (1-3/8")
NLWM39	M39 (1-1/2")
M42	M42
NLWM45	M45 (1-3/4")
M48	M48 (1-7/8")
NLWM52	M52 (2")

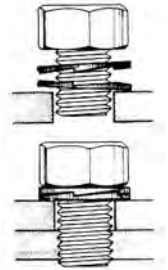

#### SP - SPECIAL SERIES\*

STOCK NO.	SIZE	O.D.
NLWM12SP	M12	1.00
NLWM20SP	M20	1.54
NLWM24SP	M24	1.91

\*LARGER O.D.



**YOUR COMPLETE SOURCE  
FOR INDUSTRIAL SUPPLIES**

**HEX NUTS**

**HEX MACHINE SCREW NUTS**

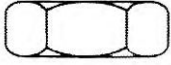

STOCK NO.	SIZE	FINISH	BOX QTY.
HN001	2-56	ZINC	100
HN002	3-48	ZINC	100
HN0029*	4-40	ZINC	100
HN003	4-40	ZINC	100
-	4-48	ZINC	-
HN004	5-40	ZINC	100
HN005	6-40	ZINC	100
HN006	6-32	ZINC	100
HN0069**	6-32	ZINC	100
HN007	8-32	ZINC	100
HN008	10-24	ZINC	100
HN009	10-32	ZINC	100
HN010	12-24	ZINC	100

\*(3/16 WIDTH ACROSS FLATS)  
\*\*(1/4 WIDTH ACROSS FLATS)

**USS COARSE THREAD HEX NUTS**



STOCK NO.	SIZE	FINISH	BOX QTY.
HN014	1/4-20	PLAIN	100
HN015	1/4-20	ZINC	100
HN016	5/16-18	ZINC	100
HN0165	3/8-16	PLAIN	100
HN017	3/8-16	ZINC	100
HN018	7/16-14	ZINC	100
HN0185	1/2-13	PLAIN	100
HN019	1/2-13	ZINC	100
HN020	9/16-12	ZINC	50
HN0205	5/18-11	PLAIN	50
HN021	5/8-11	ZINC	50
HN0215	3/4-10	PLAIN	50
HN022	3/4-10	ZINC	50
HN023	7/8-9	PLAIN	25
HN024	7/8-9	ZINC	25
HN025	1"-8	PLAIN	20
HN026	1"-8	ZINC	20
HN027	1-1/8-7	ZINC	-
HN0275	1-1/4-7	PLAIN	-
HN028	1-3/8-6	PLAIN	-
HN0282	1-5/8-5-1/2	PLAIN	-
HN0285	1-3/4-5	PLAIN	-
HN029	2"-4-1/2	PLAIN	-

**SAE FINE THREAD HEX NUTS**



STOCK NO.	SIZE	FINISH	BOX QTY.
HN030	1/4-28	ZINC	100
HN031	5/16-24	ZINC	100
HN032	3/8-24	ZINC	100
HN033	7/16-20	ZINC	100
HN034	1/2-20	ZINC	100
HN035	9/16-18	ZINC	50
HN036	5/8-18	ZINC	50
HN037	3/4-16	ZINC	25
HN038	7/8-14	ZINC	25

(CONTINUED NEXT COLUMN)

**SAE FINE THREAD HEX NUTS**



STOCK NO.	SIZE	FINISH	BOX QTY.
HN039	1"-14	ZINC	20
HN040	1"-12	PLAIN	20
HN041	1-1/8-12	PLAIN	-
HN042	1-1/4-12	PLAIN	-
HN042	1-3/8-12	PLAIN	-
HN043	1-1/2-12	PLAIN	-
-	1-5/8-12	PLAIN	-
HN0435	1-3/4-12	PLAIN	-
-	1-7/8-12	PLAIN	-
HN044	2"-12	PLAIN	-
-	2-1/4-12	PLAIN	-
HN045	2-1/2-12	PLAIN	-
HN046	3"-12	PLAIN	-

**USS COARSE THREAD GRADE 8 HEX NUTS**

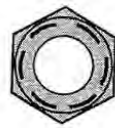

STOCK NO.	SIZE	FINISH	BOX QTY.
HN250	1/4-20	ZINC YEL.	100
HN251	5/16-18	ZINC YEL.	100
HN252	3/8-16	ZINC YEL.	100
HN253	7/16-14	ZINC YEL.	100
HN254	1/2-13	ZINC YEL.	100
HN255	9/16-12	ZINC YEL.	50
HN256	5/8-11	ZINC YEL.	50
HN257	3/4-10	ZINC YEL.	50
HN258	7/8-9	ZINC YEL.	25
HN259	1"-8	ZINC YEL.	20
HN260	1-1/8-7	PLAIN	-
HN261	1-1/4-7	PLAIN	-
HN263	1-1/2-6	PLAIN	-
HN265	1-3/4-5	PLAIN	-

**SAE FINE THREAD GRADE 8 HEX NUTS**



STOCK NO.	SIZE	FINISH	BOX QTY.
HN267	1/4-28	ZINC YEL.	100
HN268	5/16-24	ZINC YEL.	100
HN269	3/8-24	ZINC YEL.	100
HN270	7/16-20	ZINC YEL.	100
HN271	1/2-20	ZINC YEL.	100
HN272	9/16-18	ZINC YEL.	50
HN273	5/8-18	ZINC YEL.	50
HN274	3/4-16	ZINC YEL.	50
HN275	7/8-14	ZINC YEL.	25
HN276	1"-14	ZINC YEL.	25
HN277	1-1/8-12	PLAIN	-
HN278	1-1/4-12	PLAIN	-
HN279	1-1/2-12	PLAIN	-

**HEX HIGH NUT GRADE 8**



STOCK NO.	SIZE	WAF	LONG
HN445	5/8-18	15/16	27/32
HN446	3/4-16	1-1/8	1"
HN447	7/8-14	1-1/4	15/32

**USS COARSE LEFT-HAND HEX NUTS**



STOCK NO.	SIZE	FINISH	BOX QTY.
HN325	1/4-20	PLAIN	-
HN326	5/16-18	PLAIN	-
HN327	3/8-16	PLAIN	-
HN3285	7/16-14	PLAIN	-
HN329	1/2-13	PLAIN	-
HN331	5/8-11	PLAIN	-
HN333	3/4-10	PLAIN	-
HN334	7/8-9	PLAIN	-
HN335	1"-8	PLAIN-GRADE 5	-
HN336	1-1/8-7	PLAIN	-
HN337	1-1/4-7	PLAIN	-
HN339	1-1/2-6	PLAIN	-
-	1-3/4-5	PLAIN	-
HN341	2"-4-1/2	PLAIN	-

**SAE FINE LEFT-HAND HEX NUTS**



STOCK NO.	SIZE	FINISH	BOX QTY.
HN345	1/4-28	PLAIN	-
HN346	5/16-24	PLAIN	-
HN347	3/8-24	PLAIN	-
-	7/16-20	PLAIN	-
HN349	1/2-20	PLAIN	-
-	9/16-18	PLAIN	-
HN351	5/8-18	PLAIN	-
HN352	3/4-16	PLAIN	-
HN353	7/8-14	PLAIN	-
HN354	1"-14	PLAIN	-
-	1"-12	PLAIN	-
HN355	1-1/8-12	PLAIN	-
HN356	1-1/4-12	PLAIN	-
HN358	1-1/2-12	PLAIN	-
HN360	2"-12	PLAIN	-

**ADDITIONAL SIZES AVAILABLE UPON REQUEST**

### HEX NUTS

#### USS COARSE THREAD SLOTTED HEX NUTS

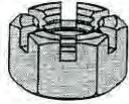

STOCK NO.	SIZE	FINISH	BOX QTY.
HN197	1/4-20	PLAIN	100
HN198	5/16-18	PLAIN	100
HN199	3/8-16	PLAIN	100
HN200	7/16-14	PLAIN	100
HN201	1/2-13	PLAIN	100
HN202	9/16-12	PLAIN	50
HN203	5/8-11	PLAIN	50
HN204	3/4-10	PLAIN	25
HN206	1"-8	PLAIN	25
-	1-1/8-7	PLAIN	-
HN208	1-1/4-7	PLAIN	-
HN209	1-1/2-6	PLAIN	-
HN2092	1-3/4-5	PLAIN	-
-	2"-4-1/2	PLAIN	-

#### USS FINE THREAD SLOTTED HEX NUTS

STOCK NO.	SIZE	FINISH	BOX QTY.
HN213	1/4-28	PLAIN	100
HN214	5/16-24	PLAIN	100
HN215	3/8-24	PLAIN	100
HN216	7/16-20	PLAIN	100
HN217	1/2-20	PLAIN	100
HN218	9/16-18	PLAIN	50
HN219	5/8-18	PLAIN	50
HN220	3/4-16	PLAIN	50
HN221	7/8-14	PLAIN	25
HN222	1"-14	PLAIN	25
-	1-1/8-12	PLAIN	-
HN224	1-1/4-12	PLAIN	-
HN225	1-3/8-12	PLAIN	-
HN226 (HVY)	1-1/2-12	PLAIN	-

#### GALVANIZED HEX NUTS



STOCK NO.	SIZE	FINISH	BOX QTY.
HN454	3/8-16	GALV.	100
HN455	1/2-13	GALV.	50
HN458	3/4-10	GALV.	25
-	1"-8	GALV.	-

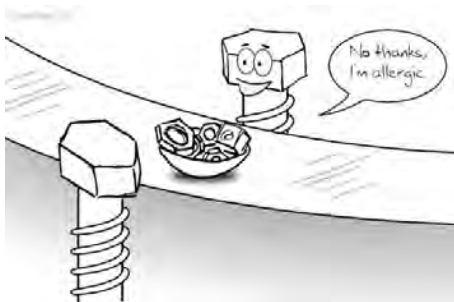

#### USS COARSE THREAD HEX JAM NUTS

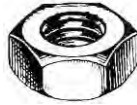

STOCK NO.	SIZE	FINISH	BOX QTY.
HN100	1/4-20	ZINC	100
HN101	5/16-18	ZINC	100
HN102	3/8-16	ZINC	100
HN103	7/16-14	ZINC	50
HN104	1/2-13	ZINC	50
-	9/16-12	ZINC	-
HN105	5/8-11	ZINC	50
HN106	3/4-10	ZINC	25
HN107	7/8-9	PLAIN	20
HN1075	7/8-9	ZINC	20
HN108	1"-8	ZINC	20
HN1085	1"-8	PLAIN	20
HN109	1-1/8-7	PLAIN	-
HN1095	1-1/4-7	PLAIN	-
HN111	1-1/2-6	PLAIN	-
HN1115	1-3/4-5	PLAIN	-
HN112	2"-4-1/2	PLAIN	-
HN1123	2-1/2-4	PLAIN	-
-	3"-4		-

#### SAE FINE THREAD HEX JAM NUTS



STOCK NO.	SIZE	FINISH	BOX QTY.
HN113	1/4-28	ZINC	100
HN114	5/16-24	ZINC	100
HN115	3/8-24	ZINC	100
HN116	7/16-20	ZINC	50
HN117	1/2-20	ZINC	50
HN1175	9/16-18	ZINC	25
HN118	5/8-18	ZINC	25
HN119	3/4-16	ZINC	25
HN120	7/8-14	ZINC	20
HN1205	1"-12	PLAIN	20
HN121	1"-14	PLAIN	20
HN122	1-1/8-12	PLAIN	-
HN123	1-1/4-12	PLAIN	-
HN1235	1-3/8-12	PLAIN	-
HN124	1-1/2-12	PLAIN	-
-	1-5/8-12	PLAIN	-
HN1245	1-3/4-12	PLAIN	-
HN1247	1-7/8-12	PLAIN	-
HN125	2"-12	PLAIN	-
HN126	2-1/4-12	PLAIN	-
HN127	2-1/2-12	PLAIN	-
HN129	3"-12	PLAIN	-

#### LEFT-HAND HEX JAM NUTS



STOCK NO.	SIZE	FINISH	BOX QTY.
HN3616	5/8-11	PLAIN	-
HN3617	3/4-10	PLAIN	-
HN3619	1"-8	PLAIN-GRADE 5	-

#### HEAVY HEX NUTS



STOCK NO.	SIZE	FINISH	BOX QTY.
HN050	1/4-20	PLAIN	100
HN0505	1/4-20	ZINC	100
HN051	5/16-18	PLAIN	100
HN0515	5/16-18	ZINC	100
HN052	3/8-16	PLAIN	100
HN0525	3/8-16	ZINC	100
HN053	7/16-14	ZINC	100
HN054	1/2-13	PLAIN	100
HN0545	1/2-13	ZINC	100
HN055	5/8-11	PLAIN	50
HN0555	5/8-11	ZINC	50
HN056	3/4-10	PLAIN	50
HN0565	3/4-10	ZINC	50
HN057	7/8-9	PLAIN	-
HN058	1"-8	PLAIN	-
HN0585	1"-8	ZINC	-
HN059	1-1/8-7	PLAIN	-
HN060	1-1/4-7	PLAIN	-
HN0605	1-3/8-6	PLAIN	-
HN061	1-1/2-6	PLAIN	-
HN062	1-3/4-5	PLAIN	-
-	1-7/8-5	PLAIN	-
HN063	2"-4-1/2	PLAIN	-
HN064	2-1/4-4-1/2	PLAIN	-
HN065	2-1/2-4	PLAIN	-
-	2-3/4-4	PLAIN	-
-	3"-4	PLAIN	-

#### 2H HEAVY HEX NUTS



STOCK NO.	SIZE	FINISH	THREAD	BOX QTY.
HN488	1/2-13	PLAIN	COARSE	-
HN489	5/8-11	PLAIN	COARSE	-
HN490	3/4-10	PLAIN	COARSE	-
HN491	7/8-9	PLAIN	COARSE	-
HN492	1"-8	PLAIN	COARSE	-
HN4925	1-1/8-7	PLAIN	COARSE	-
HN493	1-1/4-7	PLAIN	COARSE	-
HN4955	1-1/2-6	PLAIN	COARSE	-
HN4967	1-3/4-5	PLAIN	COARSE	-
HN4972	1-7/8-5	PLAIN	COARSE	-
HN4926	1-1/8-8	PLAIN	8 PITCH	-
HN494	1-1/4-8	PLAIN	8 PITCH	-
HN495	1-3/8-8	PLAIN	8 PITCH	-
HN496	1-1/2-8	PLAIN	8 PITCH	-
HN4965	1-5/8-8	PLAIN	8 PITCH	-
HN497	1-3/4-8	PLAIN	8 PITCH	-
HN498	2"-8	PLAIN	8 PITCH	-
HN499	2-1/4-8	PLAIN	8 PITCH	-
HN503	2-1/2-8	PLAIN	8 PITCH	-
HN504	2-3/4-8	PLAIN	8 PITCH	-
HN505	3"-8	PLAIN	8 PITCH	-
HN5051	3-1/4-8	PLAIN	8 PITCH	-
HN507	3-1/2-8	PLAIN	8 PITCH	-
HN525	1-1/4-12	PLAIN	FINE	-
HN526	1-1/2-12	PLAIN	FINE	-
HN530	2-1/4-12	PLAIN	FINE	-
HN531	2-1/2-12	PLAIN	FINE	-
HN532	2-3/4-12	PLAIN	FINE	-
HN534	3-1/4-12	PLAIN	FINE	-

**HEX NUTS AND MISCELLANEOUS NUTS**

**A-325 HEAVY HEX NUTS**



STOCK NO.	SIZE	FINISH	BOX QTY.
HN476	1/2-13	PLAIN	-
HN4765	5/8-11	ZINC	-
HN477	5/8-11	PLAIN	-
HN478	3/4-10	ZINC	-
HN479	3/4-10	PLAIN	-
HN480	7/8-9	PLAIN	-
HN481	1"-8	PLAIN	-
-	1-1/8-7	PLAIN	-
-	1-1/4-7	PLAIN	-

**A-325 HEAVY HEX NUTS GALVANIZED**



STOCK NO.	SIZE	FINISH	BOX QTY.
HN572	3/4-10	GALV.	-
HN573	7/8-9	GALV.	-

**ACME HEAVY HEX NUTS**



STOCK NO.	SIZE	FINISH
-	1/2-8	PLAIN
HN284	5/8-8	PLAIN
HN299	3/4-6	PLAIN
HN301	1"-5	PLAIN
HN303	1-1/4-5	PLAIN
HN304	1-1/2-4	PLAIN
-	1-3/4-4	PLAIN
-	1-3/4-5	PLAIN
HN306	2"-4	PLAIN

**HEAVY JAM NUTS**

STOCK NO.	SIZE	FINISH
HN1307	3/4-10	PLAIN
HN1308	7/8-9	ZINC
HN1309	1"-8	PLAIN
HN1311	1-1/4-7	PLAIN
HN1313	1-1/2-6	PLAIN
HN1315	1-3/4-5	PLAIN
HN1317	2"-4-1/2	PLAIN
HN1318	2-1/4-4-1/2	PLAIN
HN1319	2-1/2-4	PLAIN
HN1320	2-3/4-4	PLAIN
HN1321	3"-4	PLAIN

**2H HEAVY JAM NUTS**

STOCK NO.	SIZE	FINISH
-	1-1/8-8	PLAIN
HN136	1-1/4-8	PLAIN
HN138	1-1/2-8	PLAIN
HN140	1-3/4-8	PLAIN
HN141	1-7/8-8	PLAIN
HN142	2"-8	PLAIN
HN143	2-1/4-8	PLAIN
HN144	2-1/2-8	PLAIN



**USS COARSE THREAD NYLON INSERT LOCKNUTS**

STOCK NO.	SIZE	FINISH	BOX QTY.
-	2-56	ZINC	-
LN005	4-40	ZINC	100
LN006	5-40	ZINC	100
LN01	6-32	ZINC	100
LN02	8-32	ZINC	100
LN03	10-24	ZINC	100
LN05	12-24	ZINC	100
LN06	1/4-20	ZINC	100
LN07	5/16-18	ZINC	100
LN08	3/8-16	ZINC	100
LN09	7/16-14	ZINC	100
LN10	1/2-13	ZINC	100
LN11	9/16-12	ZINC	50
LN12	5/8-11	ZINC	50
LN13	3/4-10	ZINC	50
LN14	7/8-9	ZINC	20
LN15	1"-8	ZINC	-
LN16	1-1/8-7	ZINC	-
LN17	1-1/4-7	ZINC	-
LN18	1-3/8-6	ZINC	-
LN19	1-1/2-6	ZINC	-
LN20	1-3/4-5	ZINC	-
LN21	2"-4-1/2	ZINC	-

**SAE FINE THREAD NYLON INSERT LOCKNUTS**

STOCK NO.	SIZE	FINISH	BOX QTY.
LN04	10-32	ZINC	100
LN23	1/4-28	ZINC	100
LN24	5/16-24	ZINC	100
LN25	3/8-24	ZINC	100
LN26	7/16-20	ZINC	100
LN27	1/2-20	ZINC	100
LN28	9/16-18	ZINC	50
LN29	5/8-18	ZINC	50
LN30	3/4-16	ZINC	25
LN31	7/8-14	ZINC	15
LN32	1"-14	ZINC	-
LN33	1-1/8-12	ZINC	-
LN34	1-1/4-12	ZINC	-
-	1-3/8-12	ZINC	-
LN36	1-1/2-12	ZINC	-

**GRADE 8 COARSE THREAD NYLON INSERT LOCKNUTS**



STOCK NO.	SIZE	FINISH	BOX QTY.
LN74501	1/4-20	ZINC	100
LN74502	5/16-18	ZINC	100
LN74503	3/8-16	ZINC	100
LN74504	7/16-14	ZINC	100
LN74505	1/2-13	ZINC	100
LN74507	5/8-11	ZINC	50
LN74508	3/4-10	ZINC	50
LN74509	7/8-9	ZINC	25
LN74510	1"-8	ZINC	25

**GRADE 8 FINE THREAD NYLON INSERT LOCKNUTS**

STOCK NO.	SIZE	FINISH	BOX QTY.
LN74530	1/4-28	ZINC	100
LN74531	5/16-24	ZINC	100
LN74532	3/8-24	ZINC	100
LN74533	7/16-20	ZINC	100
LN74534	1/2-20	ZINC	100
LN74536	5/8-18	ZINC	50
LN74537	3/4-16	ZINC	50
LN74538	7/8-14	ZINC	25
LN74539	1"-14	ZINC	25

**THIN NYLON INSERT LOCKNUTS**

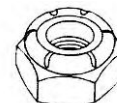

STOCK NO.	SIZE	FINISH	BOX QTY.
LN761	1/4-20	ZINC	100
LN751	1/4-28	ZINC	100
LN762	5/16-18	ZINC	100
LN752	5/16-24	ZINC	100
LN763	3/8-16	ZINC	100
LN753	3/8-24	ZINC	100
LN764	7/16-14	ZINC	100
LN754	7/16-20	ZINC	100
LN765	1/2-13	ZINC	100
LN755	1/2-20	ZINC	100
LN766	9/16-12	ZINC	50
LN756	9/16-18	ZINC	50
LN767	5/8-11	ZINC	50
LN757	5/8-18	ZINC	50
LN768	3/4-10	ZINC	50
LN758	3/4-16	ZINC	25
-	7/8-9	ZINC	-
LN759	7/8-14	ZINC	25
-	1"-8	ZINC	-
LN760	1"-14	ZINC	25

**USS COARSE THREAD GRADE C CONELOCK NUTS**



STOCK NO.	SIZE	FINISH	BOX QTY.
LN41	1/4-20	ZINC	100
LN45	5/16-18	ZINC	100
LN47	3/8-16	ZINC	100
LN48	7/16-14	ZINC	100
LN50	1/2-13	ZINC	100
LN51	9/16-12	ZINC	25
LN52	5/8-11	ZINC	50
LN54	3/4-10	ZINC	25
LN56	7/8-9	ZINC	25
LN58	1"-8	ZINC	-
LN581	1-1/8-7	ZINC	-
LN582	1-1/4-7	ZINC	-
LN583	1-3/8-6	ZINC	-
LN584	1-1/2-6	ZINC	-
-	2"-4-1/2	ZINC	-

**SAE FINE THREAD GRADE C CONELOCK NUTS**



STOCK NO.	SIZE	FINISH	BOX QTY.
LN60	1/4-28	ZINC	100
LN61	5/16-24	ZINC	100
LN63	3/8-24	ZINC	100
LN65	7/16-20	ZINC	100
LN67	1/2-20	ZINC	100
LN68	9/16-18	ZINC	25
LN69	5/8-18	ZINC	50
LN71	3/4-16	ZINC	25
LN72	7/8-14	ZINC	15
LN73	1"-14	ZINC	15
LN741	1-1/4-12	ZINC	15

**ADDITIONAL SIZES AVAILABLE UPON REQUEST**

### MISCELLANEOUS NUTS

#### GRADE G FLANGE LOCKNUTS

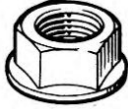

STOCK NO.	SIZE	FINISH	BOX QTY.
LN800	5/16-18	ZINC	100
LN801	3/8-16	ZINC	100
LN82	3/8-24	ZINC	100
LN803	1/2-13	ZINC	50
LN83	1/2-20	ZINC	50
LN805	5/8-11	ZINC	25
LN85	5/8-18	ZINC	25
LN806	3/4-10	ZINC	25
LN86	3/4-16	ZINC	25

#### SERRATED FLANGE LOCKNUTS

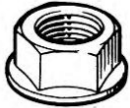

STOCK NO.	SIZE	FINISH	BOX QTY.
LN775	6-32	ZINC	100
LN776	8-32	ZINC	100
LN777	10-24	ZINC	100
LN778	10-32	ZINC	100
LN78	1/4-20	ZINC	100
LN790	1/4-28	ZINC	100
LN781	5/16-18	ZINC	100
LN791	5/16-24	ZINC	-
LN782	3/8-16	ZINC	100
-	3/8-24	ZINC	-
-	7/16-20	ZINC	-
LN783	1/2-13	ZINC	100
-	1/2-20	ZINC	-

#### KEPS LOCKNUTS



STOCK NO.	SIZE	FINISH	BOX QTY.
HN962	4-40	ZINC	100
HN963	6-32	ZINC	100
HN964	8-32	ZINC	100
HN965	10-24	ZINC	100
HN966	10-32	ZINC	100
-	12-24	ZINC	-
HN967	1/4-20	ZINC	100
HN968	5/16-18	ZINC	100
HN969	3/8-16	ZINC	100

#### REVERSIBLE LOCKNUTS



STOCK NO.	SIZE	FINISH	BOX QTY.
LN900	1/4-20	ZINC	100
-	1/4-28	ZINC	-
LN901	5/16-18	ZINC	100
-	5/16-24	ZINC	-
LN902	3/8-16	ZINC	100
-	3/8-24	ZINC	-
-	1/2-13	ZINC	-
-	1/2-20	ZINC	-

#### WING NUTS



STOCK NO.	SIZE	FINISH	BOX QTY.
-	4-40	ZINC	-
HN374	6-32	ZINC	100
HN375	8-32	ZINC	100
HN376	10-24	ZINC	100
HN377	10-32	ZINC	100
-	12-24	ZINC	-
HN378	1/4-20	ZINC	100
HN379	5/16-18	ZINC	100
HN380	3/8-16	ZINC	100
-	7/16-14	ZINC	-
HN382	1/2-13	ZINC	50
HN384	5/8-11	ZINC	25
-	3/4-10	ZINC	-

#### HEX CAP NUTS



STOCK NO.	SIZE	FINISH	BOX QTY.
HN990	6-32	NICKEL	100
HN991	8-32	NICKEL	100
HN992	10-24	NICKEL	100
HN993	10-32	NICKEL	100
HN994	1/4-20	NICKEL	100
HN995	5/16-18	NICKEL	100
HN996	3/8-16	NICKEL	100
-	7/16-14	NICKEL	-
HN997	1/2-13	NICKEL	100
-	3/4-10	NICKEL	-

#### 4-PRONG TEE NUTS



STOCK NO.	SIZE	FINISH	BOX QTY.
-	4-40	ZINC	-
-	6-32	ZINC	-
-	8-32	ZINC	-
HN424*	10-24	ZINC	-
HN4245*	10-32	ZINC	100
HN425	1/4-20	ZINC	100
HN4252*	1/4-20	ZINC	100
HN426	5/16-18	ZINC	100
HN427	3/8-16	ZINC	100

\*3-PRONG

**ADDITIONAL SIZES  
AVAILABLE UPON REQUEST**

#### SQUARE NUTS



STOCK NO.	SIZE	FINISH	BOX QTY.
-	10-32	ZINC	-
HN390	10-24	ZINC	100
HN392	1/4-20	ZINC	100
HN393	5/16-18	ZINC	100
HN394	3/8-16	ZINC	100
HN396	1/2-13	ZINC	50
HN398	5/8-11	PLAIN	25
HN399	3/4-10	PLAIN	25
HN400	7/8-9	PLAIN	25
-	1"-8	PLAIN	-
HN402 (HVY)	1"-8	PLAIN	25
-	1-1/8-7	PLAIN	-
HN404	1-1/4-7	PLAIN	-

#### U-TYPE SPEED NUTS



STOCK NO.	SIZE	TYPE	BOX QTY.
AV9879	#8	A	100
AV10666	#8	B	100
AV3770	#10	B	100
AV10048	8-32	C	50
AV2293	1/4-20	B	100
AV10050	1/4-20	C	25

#### J-TYPE CAGE NUTS (RETAINERS)



STOCK NO.	SIZE	BOX QTY.
AV5586	1/4-20	50
AV5589	5/16-18	50
AV5170	3/8-16	25

#### CAGE NUTS



STOCK NO.	SIZE	BOX QTY.
AV10773	1/4-20	25
AV3798	5/16-18	50

DELBERT AND FLETCH, TWO INDUSTRIAL ROBOTS, ESCAPED FROM THE ENGINEERING LAB ONE SATURDAY NIGHT. THEY DECIDED TO SEPARATE, PICK UP SOME DATES AND MEET LATER.

A FEW HOURS PASSED AND DELBERT ARRIVED AT THE MEETING PLACE. HE FOUND FLETCH STANDING IN FRONT OF A MAILBOX AND A FIRE ALARM. "WHO ARE YOUR TWO FRIENDS?" ASKED DELBERT. "FORGET THEM," SIGHED FLETCH. "THE SHORT, FAT ONE WITH THE BIG MOUTH JUST STANDS THERE, AND IF YOU TOUCH THE REDHEAD SHE SCREAMS HER LUNGS OUT."

**MISCELLANEOUS NUTS**

**PAL NUTS (THREAD CUTTING NUTS)**



STOCK NO.	SIZE	BOX QTY.
AV3404	3/16	200

**WHEEL NUTS**



STOCK NO.	SIZE	FINISH	BOX QTY.
AV8744	1/2-20	ZINC	100
AV8741*	1/2-20	ZINC	50

\*LEFT HAND (LIMITED STOCK)

**LICENSE PLATE NUT**



STOCK NO.	FINISH	BOX QTY.
AV3682	NYLON	50

**JACK NUT**



**DOOR MIRROR MOUNTING NUT  
ZINC WITH SEALER**

STOCK NO.	THREAD	BOX QTY.
AV12995	1/4-20	25

**HOLOKROME ALLEN NUT**



STOCK NO.	THREAD
ALLEN06044	5/16-18
ALLEN06046	3/8-16
ALLEN06050	1/2-13
ALLEN06052	5/8-11
ALLEN06054	3/4-10
ALLEN06056	7/8-9
ALLEN06058	1-8

**ROD COUPLING NUTS**



**USS COARSE THREAD - ZINC PLATED**

STOCK NO.	SIZE	LENGTH	BOX QTY.
UNT26	1/4-20	x 7/8	50
UNT27	5/16-18	x 1-1/8	25
UNT285	3/8-16	x 1-3/4	25
UNT30	1/2-13	x 1-3/4	25
UNT31	5/8-11	x 2-1/8	15
UNT32	3/4-10	x 2-1/4	15
UNT33	7/8-9	x 2-1/2	15
UNT34	1"-8	x 2-3/4	5

**FINE THREAD - ZINC PLATED**

STOCK NO.	SIZE	LENGTH	BOX QTY.
UNT51	1/4-28	x 7/8	10
UNT52	5/16-24	x 7/8	10
UNT53	3/8-24	x 1-1/16	10
UNT55	1/2-20	x 1-1/4	10

**"REDUCING" ROD COUPLING NUTS**



**USS COARSE THREAD - ZINC PLATED**

STOCK NO.	SIZE	LENGTH	BOX QTY.
UNT40	1/4-20	x 3/8-16	100
UNT41	5/16-18	x 3/8-16	50
UNT42	3/8-16	x 1/2-13	50

**EYE COUPLINGS**



EYE COUPLINGS ARE FASTENED TO EXPANSION ANCHORS OR THREADED ROD THAT HAS ALREADY BEEN INSTALLED. THEY CAN BE USED FOR HANGING PIPE, FIXTURES OR OTHER ASSEMBLIES.

STOCK NO.	SIZE
USAEC14	1/4-20
USAEC38	3/8-16

LIFE IS NOT SO SHORT BUT THAT THERE IS ALWAYS TIME FOR COURTESY.

--RALPH WALDO EMERSON

**NEOPRENE WELL NUTS**



STOCK NO.	THREAD	HOLE SIZE	FOR WALL THICKNESS
AV13009	10-32	3/8	.035 - .232
AV13010	1/4-20	1/2	.031 - .187

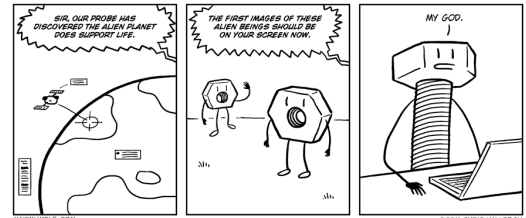

**WE STOCK OVER  
30,000 INVENTORY ITEMS.  
WE ARE  
CONSTANTLY ADDING TO  
OUR PRODUCT LINES TO  
SUIT YOUR APPLICATIONS.  
IF YOU DON'T SEE IT IN OUR CATALOG,  
CALL US.  
WE WILL DO EVERYTHING TO  
ACCOMMODATE YOUR NEEDS.**

### LAG, DRYWALL AND MISCELLANEOUS SCREWS

#### LAG SCREWS - ZINC PLATED



STOCK NO.	SIZE	BOX QTY.
LS01	1/4 x 1"	100
LS02	1/4 x 1-1/4	100
LS03	1/4 x 1-1/2	100
LS04	1/4 x 1-3/4	100
LS05	1/4 x 2"	100
LS06	1/4 x 2-1/2	100
LS07	1/4 x 3"	100
LS08	1/4 x 3-1/2	100
LS09	1/4 x 4"	100
-	1/4 x 4-1/2	-
LS10	1/4 x 5"	100
LS105	1/4 x 6"	100
LS11	5/16 x 1"	100
LS12	5/16 x 1-1/4	100
LS13	5/16 x 1-1/2	100
LS14	5/16 x 1-3/4	100
LS15	5/16 x 2"	100
LS16	5/16 x 2-1/2	100
LS17	5/16 x 3"	50
LS18	5/16 x 3-1/2	50
LS185	5/16 x 4"	50
LS186	5/16 x 4-1/2	50
LS187	5/16 x 5"	50
LS189	5/16 x 6"	50
LS19	3/8 x 1-1/4	100
LS20	3/8 x 1-1/2	100
LS21	3/8 x 2"	50
LS22	3/8 x 2-1/2	50
LS23	3/8 x 3"	50
LS24	3/8 x 3-1/2	50
LS25	3/8 x 4"	25
LS26	3/8 x 4-1/2	25
LS27	3/8 x 5"	25
-	3/8 x 5-1/2	-
LS28	3/8 x 6"	25
-	3/8 x 8"	-
-	3/8 x 10"	-
LS29	1/2 x 2"	50
LS30	1/2 x 2-1/2	50
LS31	1/2 x 3"	50
LS32	1/2 x 3-1/2	25
LS33	1/2 x 4"	25
LS34	1/2 x 5"	25
LS35	1/2 x 6"	25
LS37	1/2 x 7"	25
LS39	1/2 x 8"	25
LS43	1/2 x 10"	25
LS45	1/2 x 12"	25

5/8 AND 3/4 DIAMETERS AVAILABLE UPON REQUEST

ADDITIONAL SIZES AVAILABLE UPON REQUEST

#### DRYWALL SCREWS - PLAIN PHILLIPS HEAD FINE THREAD FOR USE WITH THIN GAUGE METAL AND WOOD

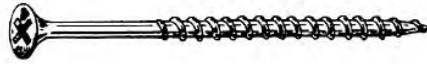

STOCK NO.	SIZE	BOX QTY.
DWS00	6 x 1"	100
DWS01	6 x 1-1/4	100
-	6 x 1-1/2	-
DWS02	6 x 1-5/8	100
DWS03	6 x 2"	100
-	8 x 2"	-
DWS04	8 x 2-1/2	100
DWS05	8 x 3"	100

#### DRYWALL SCREWS - PLAIN PHILLIPS HEAD COARSE THREAD FOR USE WITH WOOD ONLY

STOCK NO.	SIZE	BOX QTY.
DWS16	6 x 1"	100
DWS17	6 x 1-1/4	100
DWS18	6 x 1-5/8	100
DWS19	6 x 2"	100
-	6 x 2-1/4	-
-	7 x 2"	-
-	7 x 2-1/4	-
DWS27	8 x 2-1/2	100
DWS28	8 x 3"	100
DWS281	10 x 3-1/2	100
DWS282	10 x 4"	100
DWS284	10 x 5"	100

#### COATED DECK SCREWS\* PHILLIPS HEAD - COARSE THREAD

STOCK NO.	SIZE	BOX QTY.
DWS287	6 x 1-1/4	100
DWS288	6 x 1-5/8	100
DWS289	6 x 2"	100
DWS29	8 x 2-1/2	100
DWS30	8 x 3"	100

\*GREEN ZINC CHROMATE TO HELP PREVENT RUST FOR OUTDOOR WOOD APPLICATIONS

#### DRIVE SCREWS - ZINC



STOCK NO.	SIZE	BOX QTY.
DS01	#0 x 3/16	100
DS09	#2 x 3/16	100
DS10	#2 x 1/4	100
DS11	#2 x 3/8	100
DS13	#4 x 3/16	100
DS14	#4 x 1/4	100
DS19	#6 x 1/4	100
-	#6 x 1/2	-
DS23	#8 x 3/8	100
DS27	#10 x 3/8	100

#### LICENSE PLATE SCREW



STOCK NO.	SIZE	BOX QTY.	TYPE
AV8249	1/4 x 5/8	100	SL.RND.

#### THUMB SCREWS - ZINC NO SHOULDER

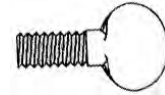

STOCK NO.	SIZE	BOX QTY.
TS006	6-32 x 3/4	100
TS011	8-32 x 3/4	100
TS11	1/4-20 x 1/2	100
TS13	1/4-20 x 1"	100
TS14	1/4-20 x 1-1/4	100
TS15	1/4-20 x 1-1/2	100
-	1/4-20 x 2"	-
TS20	5/16-18 x 3/4	100
TS21	5/16-18 x 1"	100
TS26	3/8-16 x 1"	50
TS28	3/8-16 x 1-1/2	50
TS29	3/8-16 x 2"	50

#### HEX WASHER-HEAD THREAD-CUTTING SCREWS ZINC PLATED



STOCK NO.	SIZE	BOX QTY.
AV5774	10-24 x 1/2	100
-	10-24 x 5/8	-
AV5776	10-24 x 3/4	100
AV5778	10-24 x 1"	100
AV8437	12-24 x 1/2	100
AV8438	12-24 x 3/4	100
-	12-24 x 1"	-
AV5781	1/4-20 x 3/8	100
AV5782	1/4-20 x 1/2	100
AV5784	1/4-20 x 3/4	100
AV5786	1/4-20 x 1"	100
AV5786SS*	1/4-20 x 1"	100
-	1/4-20 x 1-1/4	-
AV8441	5/16-18 x 1/2	100
AV8442	5/16-18 x 3/4	100
AV8443	5/16-18 x 1"	100
AV11294	3/8-16 x 3/4	50

\*STAINLESS STEEL

#### MISCELLANEOUS THREAD-CUTTING SCREWS

STOCK NO.	SIZE	BOX QTY.	TYPE
TCS02	2-56 x 3/8	100	SL. PAN
TCS07	4-40 x 1/4	100	PHIL. PAN
TCS09	4-40 x 1/2	100	PHIL. PAN
TCS20	8-32 x 1/2	100	PHIL. PAN

#### WOODMASTER SCREW



PATENTED SERRATED TOOTH THREAD. REQUIRES LESS DRIVING TORQUE. OUTPERFORMS TYPE 17. GREATER HOLDING POWER THAN TYPE 17. NON-SLIP RECESS. COUNTERSINKING NIBS. REDUCES SPLITTING. INCREASED BREAKING TORQUE. RAPID START. EASY DRIVING.

STOCK NO.	SIZE	BOX QTY.
SDS0050	8 x 1"	-
SDS0052	8 x 1 1/4	-
SDS0054	8 x 1 1/2	-
SDS0055	8 x 1 3/4	-
SDS0056	8 x 2"	-
SDS0058	8 x 2 1/4	-
SDS0059	8 x 2 1/2	-
SDS0061	8 x 3"	-



**FLOOR SCREWS, WOOD SCREWS AND HANGER BOLTS**

**FLAT HEAD TORX FLOOR SCREWS - PLAIN**



STOCK NO.	SIZE	BOX QTY.
FBS05	1/4 x 1-1/4	100
FBS06	1/4 x 1-1/2	100
FBS08	1/4 x 2"	100
FBS10	1/4 x 2-1/2	100
FBS12	1/4 x 3"	100
FBS23	5/16 x 2-1/2	100

**FLAT HEAD SLOTTED WOOD SCREWS - ZINC**



STOCK NO.	SIZE	BOX QTY.
WS001	4 x 1/2	100
WS002	4 x 3/4	100
WS003	6 x 1/2	100
WS004	6 x 3/4	100
WS005	6 x 1"	100
WS006	6 x 1-1/4	100
WS007	6 x 1-1/2	100
WS008	6 x 2"	100
WS009	7 x 5/8	100
WS010	8 x 1/2	100
WS011	8 x 5/8	100
WS012	8 x 3/4	100
WS013	8 x 1"	100
WS015	8 x 1-1/4	100
WS017	8 x 1-1/2	100
WS019	8 x 1-3/4	100
WS020	8 x 2"	100
WS021	8 x 2-1/2	100
WS023	8 x 3"	100
WS024	10 x 1/2	100
WS025	10 x 3/4	100
WS026	10 x 1"	100
WS027	10 x 1-1/4	100
WS029	10 x 1-1/2	100
WS031	10 x 1-3/4	100
WS032	10 x 2"	100
WS034	10 x 2-1/4	100
WS036	10 x 2-1/2	100
WS038	10 x 3"	100
WS040	10 x 3-1/2	100
WS041	10 x 4"	100
WS042	12 x 3/4	100
WS043	12 x 1"	100
WS044	12 x 1-1/4	100
WS045	12 x 1-1/2	100
WS047	12 x 1-3/4	100
WS049	12 x 2"	100
WS0491	12 x 2-1/4	100
WS050	12 x 2-1/2	100
WS051	12 x 3"	100
WS052	12 x 3-1/2	100
WS053	12 x 4"	100
WS054	14 x 3/4	100
WS055	14 x 1"	100
WS056	14 x 1-1/4	100
WS057	14 x 1-1/2	100
-	14 x 1-3/4	-
WS058	14 x 2"	100
WS060	14 x 2-1/2	100

(CONTINUED NEXT COLUMN)

**FLAT HEAD SLOTTED WOOD SCREWS - ZINC (CONTINUED)**

STOCK NO.	SIZE	BOX QTY.
WS062	14 x 2-3/4	100
WS064	14 x 3"	100
WS066	14 x 3-1/2	100
WS068	14 x 4"	100
-	14 x 4-1/2	-
WS069	14 x 5"	100
WS070	14 x 6"	100

**FLAT HEAD PHILLIPS WOOD SCREWS - ZINC**



STOCK NO.	SIZE	BOX QTY.
WS080	6 x 1/2	100
-	6 x 5/8	-
WS082	6 x 3/4	100
WS083	6 x 1"	100
WS084	6 x 1-1/4	100
-	6 x 1-1/2	-
-	6 x 1-3/4	-
-	6 x 2"	-
WS090	8 x 1/2	100
WS0905	8 x 3/4	100
WS091	8 x 1"	100
WS092	8 x 1-1/4	100
WS093	8 x 1-1/2	100
WS094	8 x 1-3/4	100
WS095	8 x 2"	100
WS096	8 x 2-1/2	100
WS097	8 x 3"	100
WS098	10 x 3/4	100
WS099	10 x 1"	100
WS100	10 x 1-1/4	100
WS101	10 x 1-1/2	100
WS102	10 x 1-3/4	100
WS103	10 x 2"	100
WS1035	10 x 2-1/4	100
WS104	10 x 2-1/2	100
WS1045	10 x 2-3/4	100
WS105	10 x 3"	100
WS1051	10 x 3-1/2	100
-	10 x 4"	-
-	12 x 3/4	-
WS106	12 x 1"	100
WS107	12 x 1-1/4	100
WS108	12 x 1-1/2	100
-	12 x 1-3/4	-
WS109	12 x 2"	100
-	12 x 2-1/4	-
WS1095	12 x 2-1/2	100
WS110	12 x 3"	100
-	12 x 3-1/2	-
WS111	12 x 4"	100
-	14 x 1"	-
-	14 x 1-1/4	-
-	14 x 1-3/4	-
-	14 x 2"	-
-	14 x 2-1/4	-
WS124	14 x 2-1/2	100
-	14 x 3"	-
-	14 x 3-1/2	-
-	14 x 4"	-
-	14 x 5"	-

**ROUND HEAD SLOTTED WOOD SCREWS - ZINC**



STOCK NO.	SIZE	BOX QTY.
WS200	2 x 3/8	100
WS201	6 x 1-3/4	100
WS202	7 x 1-1/2	100
WS203	8 x 3/4	100
WS204	8 x 1"	100
WS205	8 x 1-1/4	100
WS206	8 x 1-1/2	100
WS207	10 x 1"	100
WS208	10 x 1-1/4	100
WS209	10 x 1-1/2	100
WS210	10 x 1-3/4	100
WS211	10 x 2"	100
WS212	12 x 1-3/4	100

**HANGER BOLTS**



STOCK NO.	SIZE	BOX QTY.
HB05	1/4 x 1-1/2	50
HB06	1/4 x 2"	50
HB07	1/4 x 2-1/2	50
HB08	1/4 x 3"	50
HB15	5/16 x 2"	50
HB17	5/16 x 3"	50
HB19	5/16 x 4"	50
HB23	3/8 x 2-1/2	50
HB24	3/8 x 3"	50
HB26	3/8 x 4"	50

**ADDITIONAL SIZES  
AVAILABLE UPON REQUEST**

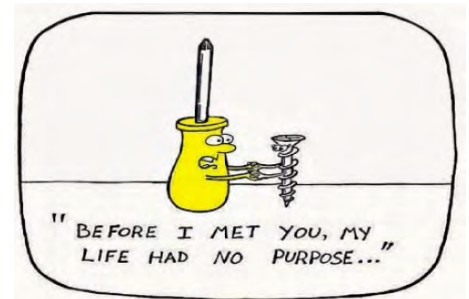

## DRILL POINT (TEK) SCREWS AND SHEET METAL SCREWS

**HEX WASHER HEAD TEK SCREWS - ZINC**



STOCK NO.	SIZE	BOX QTY.
TEK011	6 x 1/2	100
TEK013	6 x 3/4	100
TEK015	6 x 1"	100
TEK02	8 x 1/2	100
TEK03	8 x 3/4	100
TEK04	8 x 1"	100
-	8 x 1-1/4	-
TEK05	8 x 1-1/2	100
TEK08	10 x 1/2	100
-	10 x 5/8	-
TEK09	10 x 3/4	100
TEK10	10 x 1"	100
TEK105	10 x 1-1/4	100
TEK11	10 x 1-1/2	100
-	10 x 1-3/4	-
TEK112	10 x 2"	100
-	10 x 2-1/2	-
-	10 x 3"	-
-	12 x 5/8	-
TEK13	12 x 3/4	100
TEK14	12 x 1"	100
TEK15	12 x 1-1/4	100
TEK16	12 x 1-1/2	100
TEK17	12 x 2"	100
TEK171	12 x 3"	100
TEK18	1/4 x 3/4	100
TEK19	1/4 x 1"	100
TEK20	1/4 x 1-1/4	100
TEK21	1/4 x 1-1/2	100
TEK23	1/4 x 2"	100
TEK235	1/4 x 2-1/2	100
TEK24	1/4 x 3"	100
-	1/4 x 4"	-

**HEX WASHER HEAD TEK SCREWS - ZINC WITH BONDED WASHER**



STOCK NO.	SIZE	BOX QTY.
-	8 x 3/4	-
TEK30	10 x 3/4	100
TEK31	10 x 1"	100
-	12 x 1"	-
-	12 x 1-1/4	-
TEK37	12 x 2"	100
TEK39	1/4 x 3/4	100
TEK40	1/4 x 1"	100
TEK41	1/4 x 1-1/4	100
TEK42	1/4 x 1-1/2	100
TEK43	1/4 x 2"	100

**NEOPRENE-BACKED BONDED WASHERS**



STOCK NO. TEK50	(#10)
STOCK NO. TEK51	(#14)
STOCK NO. TEK54	(#10) STAINLESS STEEL
STOCK NO. TEK56	(#14) STAINLESS STEEL

**PHILLIPS PAN HEAD TEK SCREWS - ZINC**

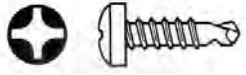

STOCK NO.	SIZE	BOX QTY.
TEK569	6 x 3/8	100
TEK57	6 x 1/2	100
TEK571	6 x 3/4	100
TEK572	6 x 1"	100
TEK60	8 x 1/2	100
TEK605	8 x 5/8	100
TEK61	8 x 3/4	100
TEK62	8 x 1"	100
TEK63	8 x 1-1/4	100
TEK64	8 x 1-1/2	100
TEK65	10 x 1/2	100
TEK655	10 x 5/8	100
TEK66	10 x 3/4	100
TEK67	10 x 1"	100
TEK68	10 x 1-1/4	100
TEK69	10 x 1-1/2	100

**STAINLESS STEEL HEX WASHER HEAD TEK SCREWS**

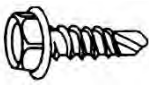

STOCK NO.	SIZE	BOX QTY.
TEK700	8 x 1/2	100
TEK701	8 x 3/4	100
TEK702	8 x 1"	100
TEK707	10 x 1/2	100
TEK708	10 x 3/4	100
TEK709	10 x 1"	100
TEK710	10 x 1-1/4	100
TEK714	12 x 3/4	100
TEK715	12 x 1"	100
TEK720	14 x 3/4	100
TEK721	14 x 1"	100
TEK722	14 x 1-1/4	100
TEK723	14 x 1-1/2	100

**PHILLIPS TRUSS HEAD TEK SCREWS - ZINC**

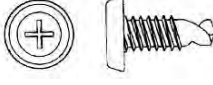

STOCK NO.	SIZE	BOX QTY.
TEK80	8 x 1/2	100
TEK81	8 x 3/4	100
TEK82	8 x 1"	100

**HEX WASHER HEAD TEK SCREWS FOR HEAVY-GAUGE METAL - ZINC**



STOCK NO.	SIZE	BOX QTY.
TEK95	12-24 x 7/8	100
TEK96	12-24 x 1-1/4	-

**PHILLIPS FLAT HEAD TEK SCREW**

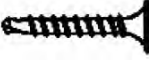

STOCK NO.	SIZE	BOX QTY.
DWS42*	6 x 1-1/4	100
TEK847	10 x 3"	100
TEK85	12-24 x 2-1/2	100

\*DRYWALL TEK

**PHILLIPS PAN HEAD TEK ROOFING SCREW BLACK OXIDE**

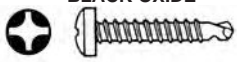

STOCK NO.	SIZE	BOX QTY.
RS100	12 x 2-1/4	100
RS102	12 x 2-7/8	100
RS104	12 x 3-1/4	100
RS106	12 x 3-3/4	100
RS109	12 x 4-1/2	100
RS111	12 x 5"	100
RS114	12 x 6"	100

**SLOTTED PAN HEAD SHEET METAL SCREWS - ZINC**



STOCK NO.	SIZE	BOX QTY.
SM001	2 x 1/4	100
SM002	4 x 1/4	100
SM003	4 x 3/8	100
SM004	4 x 1/2	100
SM0045	4 x 5/8	100
SM005	4 x 3/4	100
SM006	4 x 1"	100
SM007	6 x 1/4	100
SM008	6 x 3/8	100
SM009	6 x 1/2	100
SM010	6 x 5/8	100
SM011	6 x 3/4	100
SM012	6 x 1"	100
SM013	6 x 1-1/4	100
SM014	6 x 1-1/2	100
SM015	6 x 2"	100
-	8 x 1/4	-
SM016	8 x 3/8	100
SM017	8 x 1/2	100
SM018	8 x 5/8	100
SM019	8 x 3/4	100
SM020	8 x 1"	100
SM021	8 x 1-1/4	100
SM022	8 x 1-1/2	100
SM023	8 x 1-3/4	100
SM024	8 x 2"	100
SM025	8 x 2-1/2	100
SM026	8 x 3"	100
SM027	10 x 3/8	100
SM028	10 x 1/2	100
SM029	10 x 5/8	100
SM030	10 x 3/4	100
SM031	10 x 1"	100
SM032	10 x 1-1/4	100
SM033	10 x 1-1/2	100
SM034	10 x 1-3/4	100
-	10 x 2"	100
SM036	10 x 2-1/2	100
SM037	10 x 3"	100
SM038	12 x 1/2	100
SM039	12 x 5/8	100
SM040	12 x 3/4	100
SM041	12 x 1"	100
SM042	12 x 1-1/4	100
SM043	12 x 1-1/2	100
SM044	12 x 1-3/4	100
SM045	12 x 2"	100
SM046	12 x 2-1/2	100
SM047	12 x 3"	100
SM048	14 x 1/2	100
SM049	14 x 5/8	100
SM050	14 x 3/4	100
SM051	14 x 7/8	100
SM052	14 x 1"	100
SM053	14 x 1-1/4	100
SM054	14 x 1-1/2	100
SM055	14 x 2"	100
SM056	14 x 2-1/2	100
SM057	14 x 3	100

**SHEET METAL SCREWS**

**PHILLIPS PAN HEAD  
SHEET METAL SCREWS - ZINC**



STOCK NO.	SIZE	BOX QTY.
-	4 x 1/4	-
-	4 x 3/8	-
SM069	4 x 1/2	100
-	4 x 5/8	-
-	4 x 3/4	-
-	4 x 1"	-
SM073	6 x 1/4	100
SM074	6 x 3/8	100
SM075	6 x 1/2	100
SM0753	6 x 5/8	100
SM0755	6 x 3/4	100
-	6 x 7/8	-
SM076	6 x 1"	100
SM0761	6 x 1-1/4	100
SM0762	6 x 1-1/2	100
SM0763	6 x 1-3/4	100
SM0764	6 x 2"	100
-	8 x 1/4	-
SM077	8 x 3/8	100
SM078	8 x 1/2	100
SM0785	8 x 5/8	100
SM079	8 x 3/4	100
-	8 x 7/8	-
SM080	8 x 1"	100
SM081	8 x 1-1/4	100
SM082	8 x 1-1/2	100
SM0821	8 x 1-3/4	100
SM0822	8 x 2"	100
SM0823	8 x 2-1/4	100
SM0824	8 x 2-1/2	100
-	8 x 3"	-
SM0829	10 x 3/8	100
SM083	10 x 1/2	100
SM0835	10 x 5/8	100
SM084	10 x 3/4	100
-	10 x 7/8	-
SM085	10 x 1"	100
SM0855	10 x 1-1/4	100
SM086	10 x 1-1/2	100
SM0865	10 x 1-3/4	100
SM087	10 x 2"	100
-	10 x 2-1/4	-
SM0872	10 x 2-1/2	100
SM0874	10 x 3"	100
SM0878	12 x 1/2	100
-	12 x 5/8	-
SM088	12 x 3/4	100
-	12 x 7/8	-
SM089	12 x 1"	100
SM0891	12 x 1-1/4	100
SM0892	12 x 1-1/2	100
SM0893	12 x 1-3/4	100
SM0894	12 x 2"	100
SM0895	12 x 2-1/2	100
SM0896	12 x 3"	100
SM089625	12 x 4"	100
SM0897	14 x 1/2	100
-	14 x 5/8	-
SM0899	14 x 3/4	100
SM090	14 x 1"	100
SM091	14 x 1-1/4	100
SM0911	14 x 1-1/2	100
-	14 x 1-3/4	-
SM0913	14 x 2"	100
-	14 x 2-1/2	-
-	14 x 3"	-

**PHILLIPS FLAT HEAD  
SHEET METAL SCREWS - ZINC**



STOCK NO.	SIZE	BOX QTY.
SM0923	4 x 1/2	100
SM0925	4 x 3/4	100
-	4 x 1"	-
-	6 x 1/4	-
SM0931	6 x 3/8	100
SM0932	6 x 1/2	100
-	6 x 5/8	-
SM0934	6 x 3/4	100
-	6 x 7/8	-
SM094	6 x 1"	100
SM0941	6 x 1-1/4	100
SM0942	6 x 1-1/2	100
-	6 x 1-3/4	-
SM095	6 x 2"	100
-	6 x 2-1/2	-
SM0958	8 x 3/8	100
SM096	8 x 1/2	100
-	8 x 5/8	-
SM097	8 x 3/4	100
SM098	8 x 1"	100
SM099	8 x 1-1/4	100
SM100	8 x 1-1/2	100
SM1005	8 x 1-3/4	100
SM101	8 x 2"	100
SM102	8 x 2-1/2	100
SM1025	8 x 3"	100
SM103	10 x 1/2	100
SM104	10 x 3/4	100
SM1045	10 x 7/8	100
SM105	10 x 1"	100
SM106	10 x 1-1/4	100
SM107	10 x 1-1/2	100
SM108	10 x 1-3/4	100
SM109	10 x 2"	100
-	10 x 2-1/4	-
SM111	10 x 2-1/2	100
SM112	10 x 3"	100
-	12 x 1/2	-
SM115	12 x 3/4	100
SM116	12 x 1"	100
SM117	12 x 1-1/4	100
SM118	12 x 1-1/2	100
SM119	12 x 1-3/4	100
SM120	12 x 2"	100
SM121	12 x 2-1/2	100
SM122	12 x 3"	100
-	14 x 1/2	-
SM126	14 x 3/4	100
SM127	14 x 1"	100
SM128	14 x 1-1/4	100
SM129	14 x 1-1/2	100
SM1295	14 x 1-3/4	100
SM130	14 x 2"	100
SM131	14 x 2-1/2	100
SM132	14 x 3"	100

HOW YOU SPEND YOUR TIME IS MORE IMPORTANT THAN HOW YOU SPEND YOUR MONEY. MONEY MISTAKES CAN BE CORRECTED, BUT TIME IS GONE FOREVER.

--DAVID B. NORRIS

**HEX HEAD SHEET METAL SCREWS - ZINC**

**A) SLOTTED HEX  
W/ WASHER**



**B) SLOTTED TAPER-  
POINT (1/4" HEX HEAD)  
W/ WASHER**



STOCK NO.	SIZE	TYPE	BOX QTY.
-	6 x 3/8	A	-
SM137	6 x 1/2	A	100
SM139	6 x 3/4	A	100
-	7 x 1/2	A	-
-	7 x 3/4	A	-
-	8 x 1/4	A	-
SM150	8 x 3/8	A	100
SM151	8 x 1/2	B	100
-	8 x 5/8	A	-
SM153	8 x 3/4	B	100
SM155	8 x 1"	B	100
SM157	8 x 1-1/4	A	100
SM158	8 x 1-1/2	B	100
SM161	8 x 2"	B	100
SM165	10 x 3/8	A	100
SM166	10 x 1/2	B	100
SM1665	10 x 1/2	A	100
SM167	10 x 5/8	A	100
SM168	10 x 3/4	B	100
SM169	10 x 3/4	A	100
SM170	10 x 1"	B	100
SM171	10 x 1"	A	100
SM172	10 x 1-1/4	A	100
SM173	10 x 1-1/2	A	100
SM174	10 x 2"	A	100
SM1742	10 x 2-1/2	A	100
SM1744	10 x 3"	A	100
SM175	12 x 1/2	A	100
SM176	12 x 5/8	A	100
SM177	12 x 3/4	A	100
SM178	12 x 1"	A	100
SM1781	12 x 1-1/4	A	100
SM1782	12 x 1-1/2	A	100
SM1784	12 x 2"	A	100
SM1786	12 x 3"	A	100
SM179	14 x 1/2	A	100
SM180	14 x 5/8	A	100
SM181	14 x 3/4	A	100
SM182	14 x 1"	A	100
SM183	14 x 1-1/4	A	100
SM184	14 x 1-1/2	A	100
SM185	14 x 2"	A	100
SM186	14 x 2-1/2	A	100
SM187	14 x 3"	A	100

(SHEET METAL SCREWS CONT. NEXT PAGE)



### SHEET METAL AND TAMPER-PROOF SCREWS

#### UNSLOTTED HEX - WITHOUT WASHER

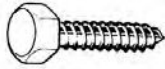

STOCK NO.	SIZE	BOX QTY.
AV2110	5/16 x 3/4	100
AV2268	5/16 x 1"	100
AV2269	5/16 x 1-1/4	100
AV3220	5/16 x 1-1/2	100
AV5690	5/16 x 2"	100
AV5330	3/8 x 1"	100
AV5331	3/8 x 1-1/4	100
AV5332	3/8 x 1-1/2	100

ADDITIONAL SIZES AVAILABLE UPON REQUEST

#### PHILLIPS OVAL HEAD SHEET METAL SCREWS - ZINC



STOCK NO.	SIZE	BOX QTY.
AV2705	8 x 3/8	100
AV2358	8 x 1/2	100
AV2359	8 x 3/4	100
AV2360	8 x 1"	100
AV2362	8 x 1-1/2	100
AV2720	10 x 1/2	100
AV2578	10 x 1"	100

SEE STAINLESS STEEL PHILLIPS OVAL SMS FOR A BETTER RANGE OF SIZES

#### SPANNER PAN HEAD SHEET METAL SCREWS TAMPER-PROOF / STAINLESS STEEL



STOCK NO.	SIZE	BOX QTY.
TPS016	8 x 1/2	100
TPS018	8 x 3/4	100
TPS019	8 x 1"	100
TPS021	8 x 1-1/2	100
TPS023	8 x 2"	100
TPS026	10 x 1/2	100
TPS027	10 x 3/4	100
TPS028	10 x 1"	100

#### PHILLIPS HEAD COMBO PAN HEAD SHEET METAL SCREW

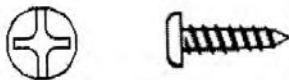

STOCK NO.	SIZE	BOX QTY.
SM0919	8 x 1"	100

#### SPANNER ROUND HEAD ONE-WAY MACHINE SCREWS TAMPER-PROOF / STAINLESS STEEL



STOCK NO.	SIZE	BOX QTY.
TPS537	1/4-20 x 3/4	100
TPS539	1/4-20 x 1"	100
TPS540	1/4-20 x 1-1/4	100

ADDITIONAL SIZES AND HEAD STYLES OF



SECURITY SCREWS AVAILABLE UPON REQUEST

### MACHINE SCREWS

#### SLOTTED FLAT HEAD MACHINE SCREWS - ZINC



STOCK NO.	SIZE	BOX QTY.
-	2-56 x 1/4	-
-	2-56 x 3/8	-
MS001	2-56 x 1/2	100
MS0015	4-40 x 1/4	100
MS002	4-40 x 3/8	100
MS003	4-40 x 1/2	100
MS004	4-40 x 3/4	100
MS0041	4-40 x 1"	100
-	5-40 x 1/4	-
MS005	6-32 x 1/4	100
MS006	6-32 x 3/8	100
MS007	6-32 x 1/2	100
MS008	6-32 x 5/8	100
MS009	6-32 x 3/4	100
MS010	6-32 x 1"	100
MS0105	6-32 x 1-1/4	100
MS011	6-32 x 1-1/2	100
-	6-32 x 1-3/4	-
MS012	6-32 x 2"	100
MS0121	6-32 x 2-1/2	100
MS0122	6-32 x 3"	100
MS013	8-32 x 1/4	100
MS014	8-32 x 3/8	100
MS015	8-32 x 1/2	100
MS016	8-32 x 3/4	100
MS017	8-32 x 1"	100

(CONTINUED NEXT COLUMN)

#### SLOTTED FLAT HEAD MACHINE SCREWS - ZINC



STOCK NO.	SIZE	BOX QTY.
MS018	8-32 x 1-1/4	100
MS019	8-32 x 1-1/2	100
-	8-32 x 1-3/4	-
MS020	8-32 x 2"	100
-	8-32 x 2-1/4	-
-	8-32 x 2-1/2	-
MS0204	8-32 x 3"	100
MS021	10-24 x 1/4	100
MS022	10-24 x 3/8	100
MS023	10-24 x 1/2	100
MS024	10-24 x 3/4	100
MS025	10-24 x 1"	100
MS026	10-24 x 1-1/4	100
MS027	10-24 x 1-1/2	100
MS028	10-24 x 1-3/4	100
MS029	10-24 x 2"	100
MS030	10-24 x 2-1/2	100
MS031	10-24 x 3"	100
-	10-24 x 3-1/2	-
MS0312	10-24 x 4"	100
-	10-24 x 4-1/2	-
-	10-24 x 5"	-
MS0319	10-32 x 1/4	100
MS032	10-32 x 5/16	100
MS033	10-32 x 3/8	100
MS034	10-32 x 1/2	100

(CONTINUED NEXT COLUMN)

#### SLOTTED FLAT HEAD MACHINE SCREWS - ZINC

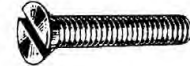

STOCK NO.	SIZE	BOX QTY.
MS035	10-32 x 5/8	100
MS036	10-32 x 3/4	100
MS037	10-32 x 1"	100
MS038	10-32 x 1-1/4	100
MS039	10-32 x 1-1/2	100
-	10-32 x 1-3/4	-
MS0392	10-32 x 2"	100
MS040	10-32 x 2-1/2	100
-	10-32 x 3"	-
MS041	12-24 x 3/8	100
MS042	12-24 x 1/2	100
MS043	12-24 x 3/4	100
MS044	12-24 x 1"	100
-	12-24 x 1-1/4	-
MS045	12-24 x 1-1/2	100
-	12-24 x 1-3/4	-
-	12-24 x 2"	-
MS046	1/4-20 x 1/2	100
MS047	1/4-20 x 5/8	100
MS048	1/4-20 x 3/4	100
MS049	1/4-20 x 1"	100
MS050	1/4-20 x 1-1/4	100
MS051	1/4-20 x 1-1/2	100
MS052	1/4-20 x 1-3/4	100
MS053	1/4-20 x 2"	100

(CONTINUED NEXT PAGE)

**MACHINE SCREWS**

**SLOTTED FLAT HEAD  
MACHINE SCREWS - ZINC**

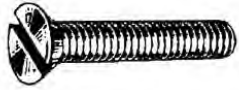

STOCK NO.	SIZE	BOX QTY.
-	1/4-20 x 2-1/4	-
MS054	1/4-20 x 2-1/2	100
MS055	1/4-20 x 3"	100
-	1/4-20 x 3-1/2	-
MS056	1/4-20 x 4"	100
-	1/4-20 x 4-1/2	-
MS0563	1/4-20 x 5"	100
-	1/4-20 x 5-1/2	-
-	1/4-20 x 6"	-
MS057	5/16-18 x 1/2	100
MS058	5/16-18 x 3/4	100
MS059	5/16-18 x 1"	100
MS060	5/16-18 x 1-1/4	100
MS061	5/16-18 x 1-1/2	100
-	5/16-18 x 1-3/4	-
MS062	5/16-18 x 2"	100
MS063	5/16-18 x 2-1/2	100
MS064	5/16-18 x 3"	100
-	5/16-18 x 3-1/2	-
MS065	5/16-18 x 4"	-
-	5/16-18 x 4-1/2	-
-	5/16-18 x 5"	100
-	5/16-18 x 5-1/2	100
-	5/16-18 x 6"	100
MS066	3/8-16 x 5/8	100
MS067	3/8-16 x 3/4	100
MS068	3/8-16 x 1"	100
MS069	3/8-16 x 1-1/4	100
MS070	3/8-16 x 1-1/2	100
-	3/8-16 x 1-3/4	-
MS071	3/8-16 x 2"	100
MS072	3/8-16 x 2-1/2	100
MS073	3/8-16 x 3"	100
-	3/8-16 x 3-1/2	-
MS0733	3/8-16 x 4"	100
-	3/8-16 x 4-1/2	-
-	3/8-16 x 5"	-
-	3/8-16 x 6"	-
MS074	1/2-13 x 3/4	50
MS075	1/2-13 x 1"	50
MS076	1/2-13 x 1-1/4	50
MS077	1/2-13 x 1-1/2	50
MS078	1/2-13 x 1-3/4	50
MS0785	1/2-13 x 2"	50
-	1/2-13 x 2-1/2	-
-	1/2-13 x 3"	-
MS07855	5/8-11 x 1-1/2	50
MS07856	5/8-11 x 1-3/4	50
MS079	5/8-11 x 2	50
-	5/8-11 x 2-1/4	-
MS080	5/8-11 x 2-1/2	50
MS081	5/8-11 x 3"	25
-	3/4-10 x 2"	-
-	3/4-10 x 2-1/2	-
MS085	3/4-10 x 3"	25
-	3/4-10 x 4"	-

ADDITIONAL SIZES AVAILABLE UPON REQUEST

**SLOTTED ROUND HEAD  
MACHINE SCREWS - ZINC**



STOCK NO.	SIZE	BOX QTY.
-	2-56 x 3/16	-
MS198	2-56 x 1/4	100
-	2-56 x 5/16	-
MS200	2-56 x 3/8	100
MS201	2-56 x 1/2	100
MS202	2-56 x 3/4	100
MS203	3-48 x 3/16	100
MS204	3-48 x 1/4	100
-	3-48 x 1/2	-
-	3-48 x 3/4	-
MS205	4-40 x 3/16	100
MS206	4-40 x 1/4	100
MS207	4-40 x 5/16	100
MS208	4-40 x 3/8	100
MS209	4-40 x 1/2	100
MS210	4-40 x 3/4	100
MS211	4-40 x 1"	100
MS212	4-40 x 1-1/2	100
MS213	5-40 x 1/4	100
MS2135	5-40 x 3/8	100
MS214	5-40 x 1/2	100
MS215	5-40 x 3/4	100
-	5-40 x 1"	-
MS216	6-32 x 3/16	100
MS217	6-32 x 1/4	100
MS218	6-32 x 3/8	100
MS219	6-32 x 1/2	100
MS220	6-32 x 5/8	100
MS221	6-32 x 3/4	100
MS222	6-32 x 7/8	100
MS223	6-32 x 1"	100
MS224	6-32 x 1-1/4	100
MS225	6-32 x 1-1/2	100
-	6-32 x 1-3/4	-
MS226	6-32 x 2"	100
-	6-32 x 2-1/4	-
MS227	6-32 x 2-1/2	100
-	6-32 x 2-3/4	-
MS228	6-32 x 3"	100
-	6-32 x 3-1/2	-
MS229	6-32 x 4"	100
MS230	8-32 x 1/4	100
MS231	8-32 x 3/8	100
MS232	8-32 x 1/2	100
MS233	8-32 x 5/8	100
MS234	8-32 x 3/4	100
MS235	8-32 x 1"	100
MS236	8-32 x 1-1/4	100
MS237	8-32 x 1-1/2	100
MS238	8-32 x 1-3/4	100
MS239	8-32 x 2"	100
MS2395	8-32 x 2-1/4	100
MS240	8-32 x 2-1/2	100
MS241	8-32 x 3"	100
MS242	8-32 x 3-1/2	100
MS243	8-32 x 4"	100
MS2431	8-32 x 4-1/2	100
MS244	10-32 x 1/4	100
MS245	10-32 x 3/8	100
MS246	10-32 x 1/2	100
MS247	10-32 x 5/8	100

(CONTINUED NEXT COLUMN)

**SLOTTED ROUND HEAD  
MACHINE SCREWS - ZINC**



STOCK NO.	SIZE	BOX QTY.
MS248	10-32 x 3/4	100
MS249	10-32 x 1"	100
MS250	10-32 x 1-1/4	100
MS251	10-32 x 1-1/2	100
MS252	10-32 x 1-3/4	100
MS253	10-32 x 2"	100
-	10-32 x 2-1/4	-
MS254	10-32 x 2-1/2	100
MS255	10-32 x 3"	100
MS256	10-32 x 3-1/2	100
MS257	10-32 x 4"	100
-	10-32 x 4-1/2	-
MS258	10-24 x 1/4	100
MS259	10-24 x 3/8	100
MS260	10-24 x 1/2	100
MS261	10-24 x 5/8	100
MS262	10-24 x 3/4	100
MS263	10-24 x 1"	100
MS264	10-24 x 1-1/4	100
MS265	10-24 x 1-1/2	100
MS266	10-24 x 1-3/4	100
MS267	10-24 x 2"	100
MS2675	10-24 x 2-1/4	100
MS268	10-24 x 2-1/2	100
-	10-24 x 2-3/4	-
MS269	10-24 x 3"	100
MS270	10-24 x 3-1/2	100
MS271	10-24 x 4"	100
MS2715	10-24 x 4-1/2	100
MS272	10-24 x 5"	100
MS2725	10-24 x 5-1/2	100
MS2726	10-24 x 6"	100
MS273	12-24 x 3/8	100
MS274	12-24 x 1/2	100
MS275	12-24 x 3/4	100
MS276	12-24 x 1"	100
MS277	12-24 x 1-1/4	100
MS278	12-24 x 1-1/2	100
MS279	12-24 x 1-3/4	100
MS280	12-24 x 2"	100
MS2809	1/4-20 x 1/4	100
MS281	1/4-20 x 3/8	100
MS282	1/4-20 x 1/2	100
MS283	1/4-20 x 5/8	100
MS284	1/4-20 x 3/4	100
-	1/4-20 x 7/8	-
MS285	1/4-20 x 1"	100
MS286	1/4-20 x 1-1/4	100
MS287	1/4-20 x 1-1/2	100
MS288	1/4-20 x 1-3/4	100
MS289	1/4-20 x 2"	100
MS290	1/4-20 x 2-1/4	100
MS291	1/4-20 x 2-1/2	100
MS292	1/4-20 x 3"	100
MS293	1/4-20 x 3-1/2	100
MS294	1/4-20 x 4"	100
MS295	1/4-20 x 4-1/2	100
MS296	1/4-20 x 5"	100
MS297	1/4-20 x 5-1/2	100
MS298	1/4-20 x 6"	100

(CONTINUED NEXT COLUMN)

### MACHINE SCREWS

#### SLOTTED ROUND HEAD MACHINE SCREWS - ZINC



STOCK NO.	SIZE	BOX QTY.
MS299	5/16-18 x 1/2	100
MS300	5/16-18 x 3/4	100
MS301	5/16-18 x 1"	100
MS302	5/16-18 x 1-1/4	100
MS303	5/16-18 x 1-1/2	100
MS304	5/16-18 x 2"	100
MS305	5/16-18 x 2-1/2	100
MS306	5/16-18 x 3"	100
MS307	5/16-18 x 3-1/2	100
MS308	5/16-18 x 4"	100
-	5/16-18 x 4-1/2	-
MS3085	5/16-18 x 5"	100
-	5/16-18 x 5-1/2	-
MS309	5/16-18 x 6"	100
MS3094	3/8-16 x 3/4	100
MS3096	3/8-16 x 1"	100
MS3097	3/8-16 x 1-1/4	100
MS310	3/8-16 x 1-1/2	100
MS311	3/8-16 x 2"	100
MS312	3/8-16 x 2-1/2	100
MS313	3/8-16 x 3"	100
-	3/8-16 x 3-1/2	-
MS314	3/8-16 x 4"	25
-	3/8-16 x 4-1/2	-
MS3145	3/8-16 x 5"	25
MS315	3/8-16 x 6"	25

#### SLOTTED FILLISTER HEAD MACHINE SCREWS - ZINC



STOCK NO.	SIZE	BOX QTY.
MS318	4-40 x 3/16	100
MS319	4-40 x 3/8	100
MS320	4-40 x 5/8	100
MS321	10-24 x 3/8	100
MS322	10-24 x 5/8	100
MS3229	10-24 x 1-1/2	100
MS323	10-24 x 2"	100
MS3238	1/4-20 x 1/2	100
MS3239	1/4-20 x 3/4	100
MS324	1/4-20 x 1"	100
MS3243	1/4-20 x 2-1/2	100

#### UNSLOTTED HEX HEAD MACHINE SCREWS - ZINC

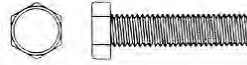

STOCK NO.	SIZE	BOX QTY.
MS325	6-32 x 1/2	100
MS3252	6-32 x 3/4	100
-	6-32 x 1"	-
MS326	8-32 x 1/2	100
MS3265	8-32 x 3/4	100
MS327	8-32 x 1"	100
-	8-32 x 1-1/4	-
-	8-32 x 1-1/2	-
-	10-32 x 3/8	-
MS3275	10-32 x 1/2	100
MS328	10-32 x 3/4	100
MS3285	10-32 x 1"	100
-	10-32 x 1-1/4	-
MS329	10-32 x 1-1/2	100
-	10-32 x 2"	-
-	10-24 x 3/8	-
MS330	10-24 x 1/2	100
MS331	10-24 x 5/8	100
MS332	10-24 x 3/4	100
MS333	10-24 x 1"	100
MS3336	10-24 x 1-1/4	100
MS334	10-24 x 1-1/2	100
-	10-24 x 1-3/4	-
-	10-24 x 2"	-

#### SLOTTED PAN HEAD MACHINE SCREWS - ZINC

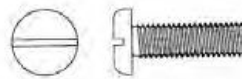

STOCK NO.	SIZE	BOX QTY.
-	2-56 x 1/4	-
-	2-56 x 3/8	-
-	2-56 x 1/2	-
MS3359	4-40 x 3/16	100
MS336	4-40 x 1/4	100
MS337	4-40 x 5/16	100
MS338	4-40 x 3/8	100
MS339	4-40 x 1/2	100
MS3393	4-40 x 5/8	100
MS3395	4-40 x 3/4	100
MS340	4-40 x 1"	100
-	5-40 x 1/4	-
MS341	5-40 x 1/2	100
MS342	6-32 x 1/4	100
MS343	6-32 x 3/8	100
MS344	6-32 x 1/2	100
MS345	6-32 x 5/8	100
MS346	6-32 x 3/4	100
MS347	6-32 x 1"	100
-	6-32 x 1-1/4	-
MS3473	6-32 x 1-1/2	100
MS3475	6-32 x 2"	100
MS348	8-32 x 1/4	100
-	8-32 x 5/16	-
MS349	8-32 x 3/8	100
MS350	8-32 x 1/2	100

(CONTINUED NEXT COLUMN)

#### SLOTTED PAN HEAD MACHINE SCREWS - ZINC

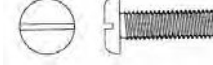

STOCK NO.	SIZE	BOX QTY.
MS3505	8-32 x 5/8	100
MS351	8-32 x 3/4	100
MS352	8-32 x 1"	100
MS3521	8-32 x 1-1/4	100
MS3522	8-32 x 1-1/2	100
MS3524	8-32 x 2"	100
MS3527	8-32 x 2-1/2	100
-	10-24 x 1/4	-
-	10-24 x 3/8	-
MS353	10-24 x 1/2	100
MS3531	10-24 x 3/4	100
-	10-24 x 1"	-
MS3533	10-24 x 1-1/4	100
-	10-24 x 1-1/2	-
-	10-24 x 2"	-
MS354	10-32 x 1/4	100
MS355	10-32 x 3/8	100
MS356	10-32 x 1/2	100
MS357	10-32 x 5/8	100
MS358	10-32 x 3/4	100
MS359	10-32 x 1"	100
-	10-32 x 1-1/4	-
-	10-32 x 1-1/2	-
-	10-32 x 2"	-
-	1/4-20 x 3/8	-
MS360	1/4-20 x 1/2	100
MS361	1/4-20 x 3/4	100
MS362	1/4-20 x 1"	100
-	1/4-20 x 1-1/4	-
-	1/4-20 x 1-1/2	-

#### PHILLIPS PAN HEAD MACHINE SCREWS - ZINC

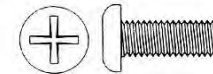

STOCK NO.	SIZE	BOX QTY.
MS391	2-56 x 3/16	100
-	4-40 x 1/4	-
MS401	4-40 x 3/8	100
MS402	4-40 x 1/2	100
-	4-40 x 3/4	-
-	4-40 x 1"	-
MS408	6-32 x 1/4	100
MS409	6-32 x 3/8	100
MS410	6-32 x 1/2	100
MS4101	6-32 x 5/8	100
MS411	6-32 x 3/4	100
MS412	6-32 x 1"	100
MS413	6-32 x 1-1/4	100
MS414	6-32 x 1-1/2	100
MS415	6-32 x 2"	100
MS416	6-32 x 2-1/2	100
MS417	6-32 x 3"	100
MS418	8-32 x 1/4	100
MS419	8-32 x 3/8	100
MS420	8-32 x 1/2	100
MS421	8-32 x 3/4	100
MS422	8-32 x 1"	100
MS423	8-32 x 1-1/4	100
MS424	8-32 x 1-1/2	100
MS425	8-32 x 1-3/4	100
MS426	8-32 x 2"	100

(CONTINUED NEXT PAGE)



**MACHINE SCREWS**

**PHILLIPS PAN HEAD  
MACHINE SCREWS - ZINC**

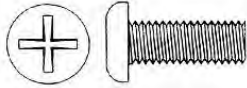

STOCK NO.	SIZE	BOX QTY.
-	10-24 x 1/4	-
MS429	10-24 x 3/8	100
MS430	10-24 x 1/2	100
MS4301	10-24 x 5/8	100
MS431	10-24 x 3/4	100
MS432	10-24 x 1"	100
MS433	10-24 x 1-1/4	100
MS434	10-24 x 1-1/2	100
MS436	10-24 x 2"	100
MS437	10-24 x 3"	100
MS4375	10-24 x 6"	100
-	10-32 x 1/4	-
MS439	10-32 x 3/8	100
MS440	10-32 x 1/2	100
MS441	10-32 x 3/4	100
MS442	10-32 x 1"	100
MS443	10-32 x 1-1/4	100
MS444	10-32 x 1-1/2	100
-	12-24 x 3/8	-
MS449	12-24 x 1/2	100
MS450	12-24 x 3/4	100
MS451	12-24 x 1"	100
-	12-24 x 1-1/4	-
-	12-24 x 1-1/2	-
-	1/4-20 x 3/8	-
MS459	1/4-20 x 1/2	100
MS460	1/4-20 x 3/4	100
MS461	1/4-20 x 1"	100
MS462	1/4-20 x 1-1/4	100
MS463	1/4-20 x 1-1/2	100
-	1/4-20 x 1-3/4	-
-	1/4-20 x 2"	-
MS466	1/4-20 x 2-1/2	100

**PHILLIPS FLAT HEAD  
MACHINE SCREWS - ZINC**

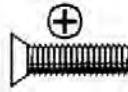

STOCK NO.	SIZE	BOX QTY.
-	2-56 x 1/4	-
-	2-56 x 3/8	-
-	2-56 x 1/2	-
-	2-56 x 3/4	-
MS704	4-40 x 1/4	100
MS705	4-40 x 3/8	100
MS706	4-40 x 1/2	100
MS707	4-40 x 3/4	100
-	4-40 x 1"	-
-	5-40 x 1/4	-
-	5-40 x 3/8	-
-	5-40 x 1/2	-
-	5-40 x 3/4	-
MS714	6-32 x 1/4	100
MS715	6-32 x 3/8	100
MS716	6-32 x 1/2	100
-	6-32 x 5/8	-
MS718	6-32 x 3/4	100
MS719	6-32 x 1"	100
-	6-32 x 1-1/4	-
-	6-32 x 1-1/2	-
MS722	8-32 x 1/4	100
MS723	8-32 x 3/8	100
MS724	8-32 x 1/2	100
MS725	8-32 x 3/4	100
MS726	8-32 x 1"	100
MS727	8-32 x 1-1/4	100
-	8-32 x 1-1/2	-
-	8-32 x 1-3/4	-
-	8-32 x 2"	-
MS729	10-24 x 3/8	100
MS730	10-24 x 1/2	100
-	10-24 x 5/8	-
MS732	10-24 x 3/4	100
MS733	10-24 x 1"	100
-	10-24 x 1-1/4	-
-	10-24 x 1-1/2	-
-	10-24 x 2"	-
-	10-32 x 1/4	-
-	10-32 x 5/16	-
MS739	10-32 x 3/8	100
MS740	10-32 x 1/2	100
-	10-32 x 5/8	-
MS742	10-32 x 3/4	100
MS743	10-32 x 1"	100
-	10-32 x 1-1/4	-
-	10-32 x 1-1/2	-
MS7455	10-32 x 1-3/4	100
-	10-32 x 2"	-
-	1/4-20 x 3/8	-
MS750	1/4-20 x 1/2	100
MS751	1/4-20 x 5/8	100
MS752	1/4-20 x 3/4	100
MS753	1/4-20 x 1"	100
-	1/4-20 x 1-1/4	-
-	1/4-20 x 1-1/2	-
MS757	1/4-20 x 2"	100

**SLOTTED TRUSS HEAD  
MACHINE SCREWS - ZINC**

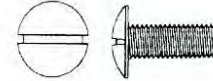

STOCK NO.	SIZE	BOX QTY.
MS482	8-32 x 1-1/4	100
-	8-32 x 1-1/2	-
MS484	8-32 x 1-3/4	100
MS518	1/4-20 x 1/2	100
MS519	1/4-20 x 3/4	100
MS521	1/4-20 x 1"	100
MS523	1/4-20 x 1-1/2	100
MS525	1/4-20 x 2"	100
MS526	1/4-20 x 2-1/2	100
MS528	1/4-20 x 3"	100
MS530	1/4-20 x 4"	100
MS535	5/16-18 x 1"	100
MS546	3/8-16 x 1"	100

*ADDITIONAL SIZES AVAILABLE UPON REQUEST*

*PHILLIPS TRUSS HEAD SCREWS  
ALSO AVAILABLE*

*ANYTHING  
ELSE  
YOU  
NEED?*

*LET US KNOW!*



*ADDITIONAL SIZES AVAILABLE UPON REQUEST*

THIS IS A COMPREHENSIVE CATALOG OF OUR MAJOR LINES AND SERVICES, BUT IT DOES NOT SHOW ALL AVAILABLE PRODUCT LINES. IF THERE IS SOMETHING YOU NEED THAT IS NOT SHOWN, WE EITHER CARRY IT OR CAN GET IT. PLEASE CALL US FOR INFORMATION.



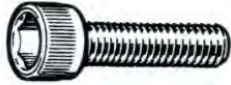

## SOCKET HEAD CAP SCREWS



STOCK NUMBER	LENGTH	BOX QTY.	STOCK NUMBER	LENGTH	BOX QTY.	STOCK NUMBER	LENGTH	BOX QTY.			
<b>2-56</b>			<b>10-24</b>			<b>1/4-20</b>					
SH00031	1/4	100	SH0228	1/4	100	SH043	3/8	100			
SH00033	3/8	100	SH0229	5/16	100	SH044	1/2	100			
SH00034	1/2	100	SH023	3/8	100	SH045	5/8	100			
<b>4-40</b>			SH024	1/2	100	SH046	3/4	100			
SH001	1/4	100	SH025	5/8	100	SH047	7/8	100			
SH002	3/8	100	SH026	3/4	100	SH048	1"	100			
SH003	1/2	100	SH027	7/8	100	SH049	1-1/4	100			
SH0035	5/8	100	SH028	1"	100	SH050	1-1/2	100			
SH004	3/4	100	SH029	1-1/4	100	SH051	1-3/4	100			
SH0042	1"	50	SH030	1-1/2	100	SH052	2"	100			
SH0043	1-1/4	50	SH031	1-3/4	100	SH053	2-1/4	100			
SH0044	1-1/2	50	SH032	2"	100	SH054	2-1/2	100			
<b>5-40</b>			SH0321	2-1/4	100	SH055	2-3/4	100			
SH006	1/4	100	SH0322	2-1/2	100	SH056	3"	100			
SH007	3/8	100	SH0324	3"	100	SH0561	3-1/4	100			
SH008	1/2	100	SH0326	3-1/2	100	SH0562	3-1/2	100			
SH0081	5/8	100	SH0328	4"	100	SH0563	3-3/4	25			
SH0082	3/4	100	<b>10-32</b>			SH0564	4"	50			
SH0084	1"	100	SH0329	1/4	100	SH0565	4-1/2	25			
<b>6-32</b>			SH033	3/8	100	SH0566	5"	25			
SH009	1/4	100	SH034	1/2	100	SH05665	5-1/2	25			
SH010	3/8	100	SH035	5/8	100	SH0567	6"	25			
SH011	1/2	100	SH036	3/4	100	<b>1/4-28 FINE THREAD</b>					
SH012	5/8	100	SH037	7/8	100	SH221	3/8	100			
SH013	3/4	100	SH038	1"	100	SH222	1/2	100			
SH0135	7/8	100	SH0385	1-1/8	100	SH223	5/8	100			
SH014	1"	100	SH039	1-1/4	100	SH224	3/4	100			
SH0141	1-1/4	50	SH040	1-1/2	100	SH225	7/8	100			
SH0142	1-1/2	50	SH041	1-3/4	100	SH226	1"	100			
SH0143	1-3/4	50	SH042	2"	100	SH227	1-1/4	100			
SH0144	2"	50	SH0421	2-1/4	100	SH228	1-1/2	100			
<b>6-40</b>			SH0422	2-1/2	100	-	1-3/4	100			
SH01492	1"	50	SH0424	3"	100	SH230	2"	100			
<b>8-32</b>			SH0425	3-1/2	100	SH2311	2-1/2	100			
SH015	1/4	100	SH0426	4"	100	<b>5/16-18</b>					
SH016	3/8	100	<b>12-24</b>			SH0569	3/8	100			
SH017	1/2	100	SH04278	1/2	100	SH057	1/2	100			
SH018	5/8	100	SH04279	3/4	100	SH058	5/8	100			
SH019	3/4	100	SH04280	1"	100	SH059	3/4	100			
SH0195	7/8	100	SH04281	1-1/4	100	SH060	7/8	100			
SH020	1"	100	SH04282	1-1/2	100	SH061	1"	100			
SH021	1-1/4	100	<b>ADDITIONAL SIZES AVAILABLE UPON REQUEST</b>			SH062	1-1/4	100			
SH022	1-1/2	100				SH063	1-1/2	100			
SH0221	1-3/4	100				SH064	1-3/4	100			
SH0222	2"	50				SH065	2"	100			
SH0223	2-1/4	50				SH066	2-1/4	50			
SH0224	2-1/2	50				SH067	2-1/2	50			
SH0225	2-3/4	50				SH068	2-3/4	50			
<b>5/16-24 FINE THREAD</b>						SH069	3"	50	SH070	3-1/4	50
SH232	1/2	100				SH071	3-1/2	50	SH0712	4"	50
SH234	3/4	100				SH0713	4-1/2	25	SH0714	5"	25
SH236	1"	100				<b>5/16-24 FINE THREAD</b>			SH237	1-1/4	100
SH237	1-1/4	100				SH238	1-1/2	100	SH239	1-3/4	100
SH238	1-1/2	100				SH240	2"	100	SH242	2-1/2"	100
SH239	1-3/4	100				SH241	3"	25	SH2421	3"	25
SH240	2"	100				<b>5/16-24 FINE THREAD</b>			SH242	2-1/2"	100
SH242	2-1/2"	100				SH2421	3"	25	SH2421	3"	25
SH2421	3"	25	<b>5/16-24 FINE THREAD</b>								





**SOCKET HEAD CAP SCREWS**



STOCK NUMBER	LENGTH	BOX QTY.	STOCK NUMBER	LENGTH	BOX QTY.	STOCK NUMBER	LENGTH	BOX QTY.
<b>3/8-16</b>			<b>7/16-20 FINE THREAD</b>			<b>5/8-11</b>		
SH072	1/2	100	-	3/4		SH121	1"	25
SH073	5/8	100	SH2535	1"	100	SH122	1-1/4	25
SH074	3/4	100	SH2536	1-1/4	100	SH123	1-1/2	25
SH075	7/8	100	SH2538	1-1/2	100	SH124	1-3/4	25
SH076	1"	100	SH2540	2"	50	SH125	2"	25
SH077	1-1/4	100				SH126	2-1/4	25
SH078	1-1/2	100				SH127	2-1/2	25
SH079	1-3/4	50				SH128	2-3/4	25
SH080	2"	50				SH129	3"	25
SH081	2-1/4	50				SH130	3-1/4	25
SH082	2-1/2	50				SH131	3-1/2	25
SH083	2-3/4	50				SH1315	3-3/4	25
SH084	3"	50				SH132	4"	25
SH085	3-1/4	25				SH133	4-1/2	20
SH086	3-1/2	25				SH134	5"	20
SH0865	3-3/4	25				SH135	5-1/2	15
SH087	4"	25				SH136	6"	15
SH0875	4-1/4	25				SH137	6-1/2	10
SH088	4-1/2	25				SH138	7"	10
SH089	5"	25				SH139	8"	10
SH0891	5-1/2	25				SH1392	9"	10
SH0892	6"	25				SH1394	10"	10
SH0893	6-1/2	10				<b>5/8-18 FINE THREAD</b>		
SH0894	7"	10				SH265	1-1/4	25
SH0896	8"	10				SH266	1-1/2	25
<b>3/8-24 FINE THREAD</b>						SH267	1-3/4	25
SH243	3/4	100				SH268	2"	25
SH244	1"	100				-	2-1/4	-
SH245	1-1/4	100				SH269	2-1/2	25
SH246	1-1/2	100				SH270	3"	25
SH247	1-3/4	100				<b>3/4-10</b>		
SH248	2"	100				SH1397	1"	25
SH249	2-1/4	100				SH140	1-1/4	25
SH250	2-1/2	50				SH141	1-1/2	25
SH251	3"	50				SH142	1-3/4	25
<b>7/16-14</b>						SH143	2"	25
SH0898	3/4	100				SH144	2-1/4	25
SH090	1"	100				SH145	2-1/2	20
SH091	1-1/4	100				SH146	2-3/4	20
SH092	1-1/2	50				SH147	3"	20
SH093	1-3/4	50				SH148	3-1/4	20
SH094	2"	50				SH149	3-1/2	20
SH0945	2-1/4	50				SH1495	3-3/4	20
SH095	2-1/2	50				SH150	4"	20
SH0955	2-3/4	50				SH151	4-1/2	-
SH096	3"	50				SH152	5"	-
SH0965	3-1/4	50				SH153	5-1/2	-
SH097	3-1/2	50				SH154	6"	-
SH098	4"	50				SH155	6-1/2	-
SH0985	4-1/2	50				SH156	7"	-
						SH1565	7-1/2	-
			<b>1/2-20 FINE THREAD</b>					
			-	3/4	50			
			SH256	1"	50			
			SH257	1-1/4	50			
			SH258	1-1/2	50			
			SH259	1-3/4	50			
			SH260	2"	50			
			-	2-1/4	50			
			SH262	2-1/2	50			
			SH263	3"	50			
			SH2631	3-1/2	25			
			SH2632	4"	25			
			SH2633	4-1/2	25			
			SH2634	5"	25			

(CONTINUED ON NEXT PAGE)

**SOCKET HEAD CAP SCREWS**

STOCK NUMBER	LENGTH	BOX QTY.	STOCK NUMBER	LENGTH	BOX QTY.	STOCK NUMBER	LENGTH	BOX QTY.
<b>3/4-10 (CONT.)</b>			<b>1-8</b>			<b>1-1/2-6</b>		
SH157	8"	-	SH1729	1-3/4	-	SH202	3"	-
SH1571	8-1/2	-	SH173	2"	-	SH203	3-1/2	-
SH1572	9"	-	SH174	2-1/4	-	SH204	4"	-
SH15725	9-1/2	-	SH175	2-1/2	-	SH205	4-1/2	-
SH1573	10"	-	SH176	2-3/4	-	SH206	5"	-
<b>3/4-16 FINE THREAD*</b>			SH177	3"	-	SH207	5-1/2	-
SH271	1-1/2	-	SH178	3-1/4	-	SH208	6"	-
SH272	1-3/4	-	SH179	3-1/2	-	SH209	6-1/2	-
SH273	2"	-	SH180	4"	-	SH210	7"	-
2735	2-1/4	-	SH181	4-1/2	-	SH211	8"	-
SH274	2-1/2	-	SH182	5"	-	SH212	9"	-
2745	2-3/4	-	SH183	5-1/2	-	SH213	10"	-
SH275	3"	-	SH184	6"	-	SH215	12"	-
SH276	3-1/2	-	SH185	6-1/2	-	<b>1-3/4-5</b>		
SH277	4"	-	SH186	7"	-	SH2160	5"	-
2772	4-1/2	-	SH1865	7-1/2	-	<p><b>*ALL FINE THREAD SOCKET CAP SCREWS IN 3/4" DIAMETER &amp; LARGER ARE CONSIDERED SEMI-STANDARD... AVAILABLE BUT PRICED UPON APPLICATION. LET US KNOW YOUR NEEDS</b></p>  <p><b>ADDITIONAL SIZES AVAILABLE UPON REQUEST</b></p>		
SH27721	5"	-	SH187	8"	-			
<b>7/8-9</b>			SH18725	9-1/2	-			
SH1578	1-1/2	-	SH1875	12"	-			
SH158	2"	-	SH18752	13"	-			
SH159	2-1/4	-	<b>1-14</b>					
SH160	2-1/2	-	SH27751	2"	-			
SH161	2-3/4	-	SH27752	2-1/2	-			
SH162	3"	-	SH27753	3"	-			
SH163	3-1/4	-	SH27754	3-1/2	-			
SH164	3-1/2	-	SH27755	4"	-			
SH165	4"	-	SH27757	5"	-			
SH166	4-1/2	-	SH27759	6"	-			
SH167	5"	-	<b>1-1/8-7</b>					
SH168	5-1/2	-	SH18762	3"	-			
SH169	6"	-	SH18768	4-1/2	-			
SH170	6-1/2	-	SH18769	5"	-			
SH171	7"	-	<b>1-1/4-7</b>					
SH1715	7-1/2	-	SH188	2-1/2	-			
SH172	8"	-	SH189	3"	-			
<b>7/8-14</b>			SH1895	3-1/4	-			
SH27734	2"	-	SH190	3-1/2	-			
SH277345	2-1/2	-	SH191	4"	-			
SH277346	3"	-	SH192	4-1/2	-			
SH277366	3-1/2	-	SH193	5"	-			
SH27738	4"	-	SH194	5-1/2	-			
SH27740	5"	-	SH195	6"	-			
SH27742	6"	-	SH196	6-1/2	-			
SH27744	7"	-	SH197	7"	-			
			SH198	8"	-			
			SH199	9"	-			
			SH200	10"	-			

**BUTTON HEAD SOCKET CAP SCREWS**

**BUTTON HEAD SOCKET CAP SCREWS**



STOCK NO.	SIZE	BOX QTY.
SH282	4-40 x 1/4	100
SH2822	4-40 x 3/8	100
SH2824	4-40 x 1/2	100
SH283	6-32 x 1/4	100
SH284	6-32 x 3/8	100
SH285	6-32 x 1/2	100
-	6-32 x 5/8	-
-	6-32 x 3/4	-
-	6-32 x 1"	-
SH287	8-32 x 1/4	100
-	8-32 x 5/16	-
SH288	8-32 x 3/8	100
SH289	8-32 x 1/2	100
SH290	8-32 x 5/8	100
SH291	8-32 x 3/4	100
SH2912	8-32 x 1"	100
SH2914	8-32 x 1-1/2	100
-	10-24 x 1/4	-
SH300	10-24 x 3/8	100
SH301	10-24 x 1/2	100
SH302	10-24 x 5/8	100
SH303	10-24 x 3/4	100
SH305	10-24 x 1"	100
-	10-24 x 1-1/4	-
SH307	10-24 x 1-1/2	100
SH308	10-24 x 1-3/4	100
-	10-24 x 2"	-
SH292	10-32 x 1/4	100
SH293	10-32 x 3/8	100
SH294	10-32 x 1/2	100
SH295	10-32 x 5/8	100
SH296	10-32 x 3/4	100
SH298	10-32 x 1"	100
SH312	1/4-20 x 3/8	100
SH313	1/4-20 x 1/2	100
SH314	1/4-20 x 5/8	100
SH315	1/4-20 x 3/4	100
SH316	1/4-20 x 7/8	100
SH317	1/4-20 x 1"	100
SH3175	1/4-20 x 1-1/4	100
SH318	1/4-20 x 1-1/2	100
-	1/4-20 x 1-3/4	-
SH3182	1/4-20 x 2"	100
SH3184	1/4-20 x 2-1/2	50
SH3409	1/4-28 x 3/8	100
SH3410	1/4-28 x 1/2	100
SH3412	1/4-28 x 3/4	100
SH3414	1/4-28 x 1"	100

**BUTTON HEAD SOCKET CAP SCREWS (CONT.)**

STOCK NO.	SIZE	BOX QTY.
SH3189	5/16-18 x 3/8	100
SH319	5/16-18 x 1/2	100
SH320	5/16-18 x 5/8	100
SH321	5/16-18 x 3/4	100
SH322	5/16-18 x 7/8	100
SH323	5/16-18 x 1"	100
SH324	5/16-18 x 1-1/4	100
SH325	5/16-18 x 1-1/2	100
SH326	5/16-18 x 1-3/4	50
-	5/16-18 x 2"	-
SH3422	5/16-24 x 1/2	100
SH3426	5/16-24 x 3/4	100
SH3428	5/16-24 x 7/8	100
SH3430	5/16-24 x 1"	100
SH328	3/8-16 x 1/2	100
-	3/8-16 x 5/8	-
SH330	3/8-16 x 3/4	100
SH331	3/8-16 x 7/8	100
SH332	3/8-16 x 1"	100
SH333	3/8-16 x 1-1/4	100
SH334	3/8-16 x 1-1/2	50
SH335	3/8-16 x 1-3/4	50
SH3351	3/8-16 x 2"	50
SH3353	3/8-16 x 2-1/2	50
SH3436	3/8-24 x 3/4	100
SH3438	3/8-24 x 1"	100
SH3359	1/2-13 x 3/4	50
SH336	1/2-13 x 1"	50
SH337	1/2-13 x 1-1/4	50
SH338	1/2-13 x 1-1/2	50
SH3385	1/2-13 x 1-3/4	50
SH339	1/2-13 x 2"	50
-	1/2-13 x 2-1/2	-
-	1/2-13 x 3"	-

**ADDITIONAL SIZES  
AVAILABLE UPON REQUEST**

**FOR MORE EFFICIENT  
BUYING, PLEASE HAVE  
STOCK NUMBERS READY  
WHEN PLACING YOUR  
ORDER**

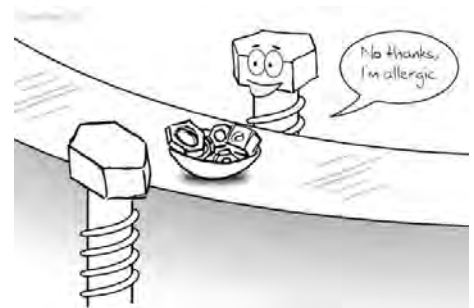

**FLAT HEAD SOCKET CAP SCREWS**

**FLAT HEAD SOCKET CAP SCREWS**



STOCK NO.	SIZE	BOX QT.
SH346	4-40 x 1/4	100
SH347	4-40 x 3/8	100
SH348	4-40 x 1/2	100
SH349	4-40 x 5/8	100
-	4-40 x 3/4	-
-	5-40 x 1/4	-
SH3513	5-40 x 3/8	100
-	5-40 x 1/2	-
-	5-40 x 3/4	-
SH354	6-32 x 1/4	100
SH355	6-32 x 3/8	100
SH356	6-32 x 1/2	100
SH357	6-32 x 5/8	100
SH358	6-32 x 3/4	100
SH360	8-32 x 3/8	100
SH361	8-32 x 1/2	100
SH362	8-32 x 5/8	100
SH363	8-32 x 3/4	100
SH364	8-32 x 1"	100
SH365	10-24 x 3/8	100
SH366	10-24 x 1/2	100
SH367	10-24 x 5/8	100
SH368	10-24 x 3/4	100
SH369	10-24 x 1"	100
SH370	10-24 x 1-1/4	100
-	10-24 x 1-1/2	-
SH3712	10-24 x 2"	100
SH3714	10-24 x 2-1/2	100
SH372	10-32 x 3/8	100
SH373	10-32 x 1/2	100
SH374	10-32 x 5/8	100
SH375	10-32 x 3/4	100
SH376	10-32 x 1"	100
SH377	10-32 x 1-1/4	100
SH378	10-32 x 1-1/2	100
-	10-32 x 2"	-
SH379	1/4-20 x 3/8	100
SH380	1/4-20 x 1/2	100
SH381	1/4-20 x 5/8	100
SH382	1/4-20 x 3/4	100
SH3825	1/4-20 x 7/8	100
SH383	1/4-20 x 1"	100
SH384	1/4-20 x 1-1/4	100
SH385	1/4-20 x 1-1/2	100
SH386	1/4-20 x 1-3/4	100
SH387	1/4-20 x 2"	100
SH388	1/4-20 x 2-1/4	100
SH389	1/4-20 x 2-1/2	100
SH390	1/4-20 x 2-3/4	100
-	1/4-20 x 3"	-
SH44708	1/4-28 x 3/8	100
SH44709	1/4-28 x 1/2	100
SH44710	1/4-28 x 5/8	100
SH44711	1/4-28 x 3/4	100
SH44712	1/4-28 x 1"	100
-	1/4-28 x 1-1/4	-
-	1/4-28 x 1-1/2	-

**FLAT HEAD SOCKET CAP SCREWS (CONT.)**

SH393	5/16-18 x 1/2	100
SH394	5/16-18 x 5/8	100
SH395	5/16-18 x 3/4	100
SH396	5/16-18 x 1"	100
SH397	5/16-18 x 1-1/4	100
SH398	5/16-18 x 1-1/2	100
SH399	5/16-18 x 1-3/4	100
SH400	5/16-18 x 2"	100
-	5/16-18 x 2-1/4	-
SH401	5/16-18 x 2-1/2	100
SH4015	5/16-18 x 2-3/4	50
-	5/16-18 x 3"	-
SH403	5/16-18 x 3-1/2	50
-	5/16-24 x 1/2	-
-	5/16-24 x 5/8	-
SH44725	5/16-24 x 3/4	100
SH44727	5/16-24 x 1"	100
SH44728	5/16-24 x 1-1/4	100
SH44729	5/16-24 x 1-1/2	100
SH404	3/8-16 x 1/2	100
SH405	3/8-16 x 5/8	100
SH406	3/8-16 x 3/4	100
SH4065	3/8-16 x 7/8	50
SH407	3/8-16 x 1"	100
SH408	3/8-16 x 1-1/4	100
SH409	3/8-16 x 1-1/2	100
SH410	3/8-16 x 1-3/4	100
SH411	3/8-16 x 2"	100
SH412	3/8-16 x 2-1/4	100
SH413	3/8-16 x 2-1/2	100
-	3/8-16 x 2-3/4	-
SH414	3/8-16 x 3"	100
SH4145	3/8-16 x 3-1/2	25
SH44736	3/8-24 x 3/4	100
SH44737	3/8-24 x 1"	100
SH44738	3/8-24 x 1-1/4	100
SH44739	3/8-24 x 1-1/2	100
SH418	7/16-14 x 1"	100
SH419	7/16-14 x 1-1/4	100
SH420	7/16-14 x 1-1/2	100
SH4202	7/16-14 x 2"	50
SH421	1/2-13 x 3/4	50
SH422	1/2-13 x 1"	50
SH423	1/2-13 x 1-1/4	50
SH424	1/2-13 x 1-1/2	50
SH425	1/2-13 x 1-3/4	50
SH426	1/2-13 x 2"	50
SH427	1/2-13 x 2-1/4	50
SH428	1/2-13 x 2-1/2	50
-	1/2-13 x 2-3/4	-
SH429	1/2-13 x 3"	50
SH430	1/2-13 x 3-1/2	25
SH431	1/2-13 x 4"	25
-	1/2-13 x 4-1/2	-
SH4313	1/2-13 x 5"	10
SH44748	1/2-20 x 1-1/4	100
SH44749	1/2-20 x 1-1/2	100
-	1/2-20 x 2"	-
SH432	5/8-11 x 1"	-
SH433	5/8-11 x 1-1/4	-
SH434	5/8-11 x 1-1/2	-
SH435	5/8-11 x 1-3/4	-
SH436	5/8-11 x 2"	-
SH437	5/8-11 x 2-1/4	-
SH438	5/8-11 x 2-1/2	-

**FLAT HEAD SOCKET CAP SCREWS (CONT.)**

-	5/8-11 x 2-3/4	-
SH439	5/8-11 x 3"	-
SH4391	5/8-11 x 3-1/2	-
SH4392	5/8-11 x 4"	-
SH4393	5/8-11 x 4-1/2	-
SH440	3/4-10 x 1-1/2	25
SH441	3/4-10 x 1-3/4	25
SH4414	3/4-10 x 2"	25
SH44145	3/4-10 x 2-1/4	25
SH4415	3/4-10 x 2-1/2	25
SH4416	3/4-10 x 2-3/4	25
SH442	3/4-10 x 3"	25
SH44205	3/4-10 x 3-1/2	10
SH4421	3/4-10 x 4"	10
SH4422	3/4-10 x 5"	10
SH44260	1"-8 x 2"	10
SH44261	1"-8 x 2-1/2	10
SH44264	1"-8 x 4"	10
SH44268	1"-8 x 5"	10

ADDITIONAL SIZES AVAILABLE UPON REQUEST

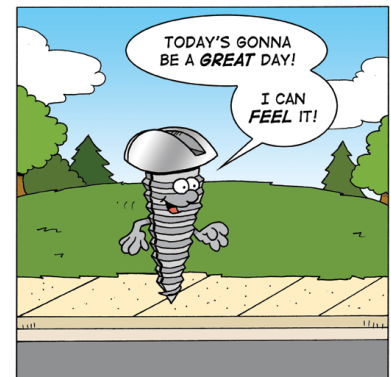

SRUPCOMICS.COM © 2010 LONNIE EASTERLING BEFORE HE GOT SCREWED

**LOW HEAD SOCKET CAP SCREWS AND SOCKET SET SCREWS**

**LOW HEAD SOCKET CAP SCREWS**



STOCK NO.	SIZE	BOX QTY.
SH44800	6-32 x 1/4	100
SH44802	6-32 x 3/8	100
SH44804	6-32 x 1/2	100
SH44806	6-32 x 3/4	100
SH44813	8-32 x 3/8	100
SH44815	8-32 x 1/2	100
SH44817	8-32 x 3/4	100
SH44819	8-32 x 1"	100
SH44826	10-24 x 3/8	100
SH44828	10-24 x 1/2	100
SH44829	10-24 x 5/8	100
SH44830	10-24 x 3/4	100
SH44832	10-24 x 1"	100
SH44839	10-32 x 3/8	100
SH44841	10-32 x 1/2	100
SH44842	10-32 x 5/8	100
SH44843	10-32 x 3/4	100
SH44845	10-32 x 1"	100
SH44850	1/4-20 x 3/8	100
SH44852	1/4-20 x 1/2	100
SH44853	1/4-20 x 5/8	100
SH44854	1/4-20 x 3/4	100
SH44856	1/4-20 x 1"	100
SH44857	1/4-20 x 1-1/4	100
SH44867	5/16-18 x 3/4	100
SH44868	5/16-18 x 7/8	100
SH44869	5/16-18 x 1"	100
SH44870	5/16-18 x 1-1/4	100
SH44871	5/16-18 x 1-1/2	100
SH44878	3/8-16 x 3/4	100
SH44880	3/8-16 x 1"	100
SH44881	3/8-16 x 1-1/4	100
SH44882	3/8-16 x 1-1/2	100
SH44887	1/2-13 x 3/4	100
SH44888	1/2-13 x 1"	50
SH44889	1/2-13 x 1-1/4	50
SH44890	1/2-13 x 1-1/2	50

**SOCKET SET SCREWS  
USS / SAE CUP POINT**



STOCK NO.	SIZE	BOX QTY.
-	4-40 x 1/8	-
SH453	4-40 x 3/16	100
SH454	4-40 x 1/4	100
SH456	4-40 x 3/8	100
SH459	5-40 x 1/8	100
SH4602	5-40 x 1/4	100
SH462	6-32 x 1/8	100
SH463	6-32 x 3/16	100
SH464	6-32 x 1/4	100
SH466	6-32 x 3/8	100
SH468	6-32 x 1/2	100
SH469	6-32 x 5/8	100
SH470	6-32 x 3/4	100
SH472	6-32 x 1"	100
SH474	8-32 x 3/16	100
SH475	8-32 x 1/4	100
SH476	8-32 x 5/16	100
SH477	8-32 x 3/8	100
SH479	8-32 x 1/2	100
SH480	8-32 x 5/8	100
SH481	8-32 x 3/4	100
SH483	8-32 x 1"	100
SH4831	8-32 x 1-1/4	100

**SOCKET SET SCREWS  
USS / SAE CUP POINT  
(CONT.)**

STOCK NO.	SIZE	BOX QTY.
SH484	10-32 x 3/16	100
SH485	10-32 x 1/4	100
SH486	10-32 x 5/16	100
SH487	10-32 x 3/8	100
SH489	10-32 x 1/2	100
SH490	10-32 x 5/8	100
SH491	10-32 x 3/4	100
SH493	10-32 x 1"	100
SH494	10-32 x 1-1/4	100
SH495	10-24 x 3/16	100
SH496	10-24 x 1/4	100
SH497	10-24 x 5/16	100
SH498	10-24 x 3/8	100
SH500	10-24 x 1/2	100
SH501	10-24 x 5/8	100
SH502	10-24 x 3/4	100
SH504	10-24 x 1"	100
SH505	10-24 x 1-1/4	100
SH506	1/4-20 x 3/16	100
SH507	1/4-20 x 1/4	100
SH508	1/4-20 x 5/16	100
SH509	1/4-20 x 3/8	100
SH510	1/4-20 x 1/2	100
SH511	1/4-20 x 5/8	100
SH512	1/4-20 x 3/4	100
SH514	1/4-20 x 1"	100
SH515	1/4-20 x 1-1/4	100
SH516	1/4-20 x 1-1/2	100
SH5165	1/4-20 x 1-3/4	100
SH5167	1/4-20 x 2"	100
SH518	1/4-20 x 2-1/4	50
SH597	1/4-28 x 1/4	100
SH598	1/4-28 x 5/16	100
SH599	1/4-28 x 3/8	100
SH600	1/4-28 x 1/2	100
SH601	1/4-28 x 5/8	100
SH602	1/4-28 x 3/4	100
SH603	1/4-28 x 1"	100
SH519	5/16-18 x 1/4	100
SH520	5/16-18 x 5/16	100
SH521	5/16-18 x 3/8	100
SH523	5/16-18 x 1/2	100
SH524	5/16-18 x 5/8	100
SH525	5/16-18 x 3/4	100
SH526	5/16-18 x 1"	100
SH527	5/16-18 x 1-1/4	100
SH528	5/16-18 x 1-1/2	100
SH530	5/16-18 x 2"	100
SH5302	5/16-18 x 2-1/2	100
SH605	5/16-24 x 1/4	100
SH606	5/16-24 x 5/16	100
SH607	5/16-24 x 3/8	100
SH609	5/16-24 x 1/2	100
SH611	5/16-24 x 3/4	100
SH612	5/16-24 x 1"	100
SH6121	5/16-24 x 1-1/4	100
SH6122	5/16-24 x 1-1/2	100



**ADDITIONAL SIZES  
AVAILABLE UPON REQUEST**

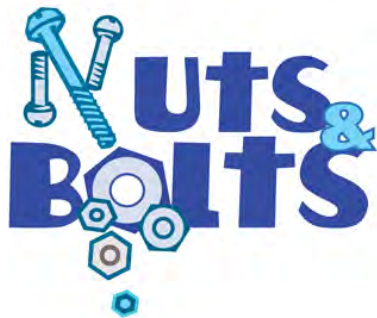

(CONTINUED NEXT PAGE)

### SOCKET SET SCREWS

#### SOCKET SET SCREWS USS / SAE CUP POINT



STOCK NO.	SIZE	BOX QTY.
SH531	3/8-16 x 1/4	100
SH532	3/8-16 x 5/16	100
SH533	3/8-16 x 3/8	100
SH535	3/8-16 x 1/2	100
SH536	3/8-16 x 5/8	100
SH537	3/8-16 x 3/4	100
SH539	3/8-16 x 1"	100
SH540	3/8-16 x 1-1/4	100
SH541	3/8-16 x 1-1/2	100
SH542	3/8-16 x 2"	100
SH5425	3/8-16 x 2-1/4	100
SH543	3/8-16 x 2-1/2	100
SH613	3/8-24 x 1/4	100
SH615	3/8-24 x 3/8	100
SH617	3/8-24 x 1/2	100
-	3/8-24 x 5/8	-
SH619	3/8-24 x 3/4	100
SH620	3/8-24 x 1"	100
SH622	3/8-24 x 1-1/2	100
SH623	3/8-24 x 2"	100
SH544	7/16-14 x 3/8	100
SH546	7/16-14 x 1/2	100
SH547	7/16-14 x 5/8	100
SH548	7/16-14 x 3/4	100
SH549	7/16-14 x 1"	100
SH624	7/16-20 x 1/2	100
-	7/16-20 x 3/4	-
SH554	1/2-13 x 3/8	100
SH555	1/2-13 x 1/2	100
SH556	1/2-13 x 5/8	100
SH557	1/2-13 x 3/4	100
SH559	1/2-13 x 1"	100
SH560	1/2-13 x 1-1/4	100
SH561	1/2-13 x 1-1/2	100
SH563	1/2-13 x 2"	50
SH564	1/2-13 x 2-1/2	50
SH565	1/2-13 x 3"	50
SH625	1/2-20 x 1/2	100
SH626	1/2-20 x 3/4	100
SH627	1/2-20 x 1"	100
SH6272	1/2-20 x 1-1/2	50
SH6274	1/2-20 x 2"	25
SH62741	1/2-20 x 2-1/4	25
SH6275	1/2-20 x 2-1/2	25
-	1/2-20 x 3"	-
SH566	9/16-12 x 1/2	25
SH567	9/16-12 x 3/4	25
SH6277	9/16-18 x 1/2	25
SH569	5/8-11 x 1/2	50
SH570	5/8-11 x 5/8	50
SH571	5/8-11 x 3/4	50
SH572	5/8-11 x 1"	50
SH573	5/8-11 x 1-1/4	50
SH574	5/8-11 x 1-1/2	50
SH575	5/8-11 x 1-3/4	50
SH576	5/8-11 x 2"	50
SH5765	5/8-11 x 2-1/2	50
SH5766	5/8-11 x 3"	50

#### SOCKET SET SCREWS USS / SAE CUP POINT (CONT.)

STOCK NO.	SIZE	BOX QTY.
SH628	5/8-18 x 5/8	50
SH6281	5/8-18 x 3/4	50
SH6282	5/8-18 x 1"	25
SH577	3/4-10 x 5/8	50
SH578	3/4-10 x 3/4	25
SH579	3/4-10 x 1"	25
SH580	3/4-10 x 1-1/4	25
SH581	3/4-10 x 1-1/2	25
SH583	3/4-10 x 2"	25
SH584	3/4-10 x 2-1/2	25
SH585	3/4-10 x 3"	25
SH630	3/4-16 x 3/4	25
SH6301	3/4-16 x 1"	25
SH587	7/8-9 x 1"	10
SH588	7/8-9 x 1-1/4	10
SH589	7/8-9 x 1-1/2	10
SH590	7/8-9 x 2"	10
SH592	1"-8 x 1"	10
SH593	1"-8 x 1-1/2	10
SH594	1"-8 x 2"	10
SH595	1"-8 x 2-1/2	10
SH596	1"-8 x 3"	10

#### SOCKET SET SCREWS USS HALF-DOG POINT



STOCK NO.	SIZE	BOX QTY.
SH6496	8-32 x 1/8	100
-	8-32 x 3/16	-
-	8-32 x 1/4	-
-	8-32 x 1/2	-
SH6505	8-32 x 3/4	100
SH6509	10-24 x 1/4	100
SH6511	10-24 x 3/8	100
SH6513	10-24 x 1/2	100
SH6521	10-32 x 1/4	100
SH6523	10-32 x 3/8	100
SH6525	10-32 x 1/2	100
SH6533	1/4-20 x 1/4	100
SH6535	1/4-20 x 3/8	100
SH6537	1/4-20 x 1/2	100
SH6549	5/16-18 x 3/8	100
SH6552	5/16-18 x 1/2	100
SH6554	5/16-18 x 3/4	100
-	3/8-16 x 3/8	-
SH6567	3/8-16 x 1/2	100
SH6569	3/8-16 x 3/4	100
SH6571	3/8-16 x 1"	100
SH6572	3/8-16 x 1-1/4	100

#### SOCKET SET SCREWS USS HALF-DOG POINT (CONT.)

STOCK NO.	SIZE	BOX QTY.
SH6584	1/2-13 x 1/2	100
SH6586	1/2-13 x 3/4	100
SH6588	1/2-13 x 1"	100
SH6604	5/8-11 x 1"	50
SH6605	5/8-11 x 1-1/4	50

#### SOCKET SET SCREWS USS KNURL POINT



STOCK NO.	SIZE	BOX QTY.
SH66546	8-32 x 1/4	100
SH66548	8-32 x 3/8	100
SH66549	8-32 x 1/2	100
SH66553	10-24 x 1/4	100
SH66555	10-24 x 3/8	100
SH66556	10-24 x 1/2	100
SH66562	10-32 x 1/4	100
SH66564	10-32 x 3/8	100
SH66565	10-32 x 1/2	100
SH66569	1/4-20 x 1/4	100
SH66571	1/4-20 x 3/8	100
SH66572	1/4-20 x 1/2	100
SH66574	1/4-20 x 3/4	100
SH66580	5/16-18 x 3/8	100
SH66581	5/16-18 x 1/2	100
SH66583	5/16-18 x 3/4	100
SH66589	3/8-16 x 3/8	100
SH66590	3/8-16 x 1/2	100
SH66592	3/8-16 x 3/4	100
SH66598	1/2-13 x 1/2	100
SH66600	1/2-13 x 3/4	100

#### SOCKET SET SCREWS USS FLAT POINT



STOCK NO.	SIZE	BOX QTY.
SH66817	10-24 x 3/16	100
SH66818	10-24 x 1/4	100
SH66820	10-24 x 3/8	100
SH66823	1/4-20 x 1/4	100
SH66825	1/4-20 x 3/8	100
SH66826	1/4-20 x 1/2	100

(CONTINUED NEXT PAGE)

**SOCKET SET SCREWS AND SHOULDER SCREWS**

**SOCKET SET SCREWS  
USS FLAT POINT  
(CONT.)**

STOCK NO.	SIZE	BOX QTY.
SH66829	5/16-18 x 3/8	100
SH66830	5/16-18 x 1/2	100
SH66833	3/8-16 x 1/2	100
SH66834	3/8-16 x 3/4	100
SH66835	3/8-16 x 1"	100

**NYLON PELLET SET SCREWS**



STOCK NO.	SIZE	BOX QTY.
SH633	1/4-20 x 1/4	100
SH634	1/4-20 x 1/2	100
SH635	5/16-18 x 3/8	-
SH6352	5/16-18 x 1/2	-
SH6458	5/16-24 x 5/16	-
SH638	3/8-16 x 1/2	-
SH641	1/2-13 x 1/2	-

**CONE POINT SET SCREWS**



STOCK NO.	SIZE	BOX QTY.
SH66685	1/4-20 x 1/4	100
SH66687	1/4-20 x 3/8	100
SH66697	5/16-18 x 3/8	100
SH66699	5/16-18 x 3/4	100
SH66706	3/8-16 x 1/2	100
SH66715	1/2-13 x 1/2	100
SH66717	1/2-13 x 3/4	100

**BRASS TIP SET SCREWS**



STOCK NO.	SIZE	BOX QTY.
BT014	8-32 x 1/4	100
BT019	10-24 x 3/16	100
BT020	10-24 x 1/4	100
BT022	10-24 x 3/8	100
BT027	10-32 x 1/4	100
BT029	10-32 x 3/8	100
BT034	1/4-20 x 1/4	100
BT036	1/4-20 x 3/8	100
BT037	1/4-20 x 1/2	100
BT041	1/4-20 x 1"	100
BT043	5/16-18 x 3/8	100
BT044	5/16-18 x 1/2	100
BT045	5/16-18 x 3/4	100
BT050	3/8-16 x 3/8	50
BT051	3/8-16 x 1/2	50
BT052	3/8-16 x 3/4	50
BT053	3/8-16 x 1"	50
BT054	3/8-16 x 1-1/4	50
BT068	1/2-13 x 1"	50
BT070	1/2-13 x 1-1/2	50

**SQUARE HEAD SET SCREWS**

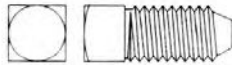

STOCK NO.	SIZE	BOX QTY.
SH671	1/4-20 x 1/2	100
SH673	1/4-20 x 3/4	100
SH674	1/4-20 x 1"	100
SH676	1/4-20 x 1-1/2	100
SH678	1/4-20 x 2"	100
SH679	1/4-20 x 3"	100
SH680	5/16-18 x 1/2	100
SH682	5/16-18 x 1"	100
SH684	5/16-18 x 1-1/2	100
SH685	5/16-18 x 2"	100
SH686	5/16-18 x 3"	100
SH688	3/8-16 x 3/4	50
SH689	3/8-16 x 1"	50
SH691	3/8-16 x 1-1/2	50
-	3/8-16 x 1-3/4	50
SH693	3/8-16 x 2"	50
SH695	3/8-16 x 2-1/2	50
SH696	3/8-16 x 3"	50
SH697	3/8-16 x 4"	50
SH699	3/8-16 x 5"	50
SH6992	3/8-16 x 6"	25
SH701	1/2-13 x 1"	25
SH702	1/2-13 x 1-1/4	25
SH703	1/2-13 x 1-1/2	25
SH704	1/2-13 x 2"	25
SH706	1/2-13 x 2-1/2	25
SH708	1/2-13 x 3"	25
SH709	1/2-13 x 3-1/2	25
SH710	1/2-13 x 4"	25
SH7105	1/2-13 x 4-1/2	25
SH711	1/2-13 x 5"	25
SH712	1/2-13 x 6"	25
SH717	5/8-11 x 1-1/2	25
SH719	5/8-11 x 2"	25
SH720	5/8-11 x 2-1/2	25
SH721	5/8-11 x 3"	25
SH722	5/8-11 x 3-1/2	25
SH723	5/8-11 x 4"	25
SH724	5/8-11 x 4-1/2	25
SH725	5/8-11 x 5"	25
SH726	5/8-11 x 6"	25
SH729	3/4-10 x 1-1/2	25
SH730	3/4-10 x 2"	25
SH731	3/4-10 x 2-1/2	25
SH732	3/4-10 x 3"	25
SH733	3/4-10 x 3-1/2	25
SH734	3/4-10 x 4"	25
SH736	3/4-10 x 5"	25
SH737	3/4-10 x 6"	10
SH739	3/4-10 x 8"	-
SH742	7/8-9 x 2"	-
SH743	7/8-9 x 3"	-
SH745	7/8-9 x 4"	-
SH746	7/8-9 x 4-1/2	-
SH747	7/8-9 x 5"	-
SH748	7/8-9 x 6"	-
SH752	1"-8 x 2"	-
SH753	1"-8 x 3"	-
SH754	1"-8 x 4"	-
SH755	1"-8 x 5"	-
SH756	1"-8 x 6"	-
SH757	1"-8 x 7"	-

**SHOULDER SCREWS**

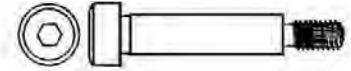

STOCK NO.	SIZE	BOX QTY.
SH765	1/4 x 3/8	25
SH766	1/4 x 1/2	25
SH767	1/4 x 5/8	25
SH768	1/4 x 3/4	25
SH769	1/4 x 1"	25
SH770	1/4 x 1-1/4	25
SH771	1/4 x 1-1/2	25
SH7713	1/4 x 2"	25
SH77198	5/16 x 1/4	25
SH772	5/16 x 3/8	25
SH773	5/16 x 1/2	25
SH774	5/16 x 5/8	25
SH775	5/16 x 3/4	25
SH776	5/16 x 1"	25
SH777	5/16 x 1-1/4	25
SH778	5/16 x 1-1/2	25
SH779	5/16 x 1-3/4	25
SH780	5/16 x 2"	25
SH781	3/8 x 3/8	25
SH782	3/8 x 1/2	25
SH783	3/8 x 5/8	25
SH784	3/8 x 3/4	25
SH785	3/8 x 1"	25
SH786	3/8 x 1-1/4	25
SH787	3/8 x 1-1/2	25
SH788	3/8 x 1-3/4	25
SH789	3/8 x 2"	25
SH790	3/8 x 2-1/4	25
SH791	3/8 x 2-1/2	25
SH792	3/8 x 2-3/4	25
SH793	3/8 x 3"	25
SH794	3/8 x 3-1/4	25
SH795	3/8 x 3-1/2	25
SH796	3/8 x 4"	25
SH797	1/2 x 1/2	25
SH798	1/2 x 5/8	25
SH799	1/2 x 3/4	25
SH800	1/2 x 1"	25
SH801	1/2 x 1-1/4	25
SH802	1/2 x 1-1/2	25
SH803	1/2 x 1-3/4	25
SH804	1/2 x 2"	25
SH805	1/2 x 2-1/4	25
SH806	1/2 x 2-1/2	25
SH807	1/2 x 2-3/4	25
SH808	1/2 x 3"	25
SH809	1/2 x 3-1/4	25
SH810	1/2 x 3-1/2	25
SH812	1/2 x 4"	25
SH813	1/2 x 4-1/4	25
SH814	1/2 x 4-1/2	10
SH815	1/2 x 4-3/4	10
SH816	1/2 x 5"	10
SH8165	5/8 x 1/2	10
SH8168	5/8 x 1"	10
SH817	5/8 x 1-1/4	10
SH818	5/8 x 1-1/2	10
SH819	5/8 x 1-3/4	10
SH820	5/8 x 2"	10
SH821	5/8 x 2-1/4	10
SH822	5/8 x 2-1/2	10
SH823	5/8 x 2-3/4	10
SH824	5/8 x 3"	10

(CONTINUED NEXT PAGE)

MANY ADDITIONAL SIZES FOR ALL ITEMS  
AVAILABLE UPON REQUEST

### SHOULDER SCREWS AND DOWEL PINS

#### SHOULDER SCREWS (CONT.)

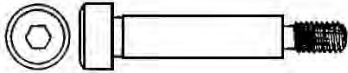

STOCK NO.	SIZE	BOX QTY.
SH825	5/8 x 3-1/4	10
SH826	5/8 x 3-1/2	10
SH827	5/8 x 3-3/4	10
SH828	5/8 x 4"	10
SH829	5/8 x 4-1/4	10
SH830	5/8 x 4-1/2	10
SH831	5/8 x 4-3/4	10
SH832	5/8 x 5"	10
SH833	5/8 x 5-1/2	10
SH834	5/8 x 6"	10
SH83451	3/4 x 1"	10
SH835	3/4 x 1-1/2	10
SH836	3/4 x 1-3/4	10
SH837	3/4 x 2"	10
SH838	3/4 x 2-1/4	10
SH839	3/4 x 2-1/2	10
SH840	3/4 x 2-3/4	10
SH841	3/4 x 3"	10
SH8412	3/4 x 3-1/4	10
SH8413	3/4 x 3-1/2	10
SH8416	3/4 x 4"	10
SH8418	3/4 x 4-1/2	10
SH8422	3/4 x 5"	10
SH8457	1" x 1-1/2	10
SH8466	1" x 4"	10
SH8502	1-1/4 x 1-1/4	10

**ADDITIONAL SIZES AVAILABLE UPON REQUEST**

**LET US HELP YOU WITH SPECIAL APPLICATION PRODUCTS. IF IT'S NOT IN THE CATALOG, IT'S UP TO US TO GET IT FOR YOU!**

#### DOWEL PINS



STOCK NO.	SIZE	BOX QTY.
SH8554	3/32 x 1/2	100
SH8557	3/32 x 3/4	100
SH8559	3/32 x 1"	100
SH85599	1/8 x 3/8	100
SH856	1/8 x 1/2	100
SH857	1/8 x 5/8	100
SH858	1/8 x 3/4	100
SH860	1/8 x 1"	100
SH861	1/8 x 1-1/2	100
SH862	1/8 x 2"	100
SH863	3/16 x 1/2	100
SH864	3/16 x 5/8	100
SH865	3/16 x 3/4	100
SH866	3/16 x 1"	100
SH867	3/16 x 1-1/4	100
SH868	3/16 x 1-1/2	100
SH870	3/16 x 2"	100
SH8702	3/16 x 2-1/2	100
SH871	1/4 x 1/2	100
SH872	1/4 x 5/8	100
SH873	1/4 x 3/4	100
SH874	1/4 x 7/8	100
SH875	1/4 x 1"	100
SH876	1/4 x 1-1/4	100
SH877	1/4 x 1-1/2	100
SH878	1/4 x 1-3/4	100
SH879	1/4 x 2"	100
SH881	1/4 x 2-1/2	100
SH882	1/4 x 3"	100
SH883	1/4 x 4"	100
SH8838	5/16 x 1/2	100
SH884	5/16 x 3/4	100
SH886	5/16 x 1"	100
SH887	5/16 x 1-1/4	100
SH888	5/16 x 1-1/2	100
SH890	5/16 x 2"	100
SH891	5/16 x 2-1/4	100
SH892	5/16 x 2-1/2	100
SH894	5/16 x 3"	100
SH896	3/8 x 3/4	100
SH897	3/8 x 1"	100
SH898	3/8 x 1-1/4	100
SH899	3/8 x 1-1/2	100
SH900	3/8 x 1-3/4	100
SH901	3/8 x 2"	100
SH902	3/8 x 2-1/4	100
SH903	3/8 x 2-1/2	100
SH904	3/8 x 3"	50
SH905	3/8 x 3-1/2	50
SH906	7/16 x 1-1/2	25
SH910	1/2 x 1"	100
SH911	1/2 x 1-1/4	50
SH912	1/2 x 1-1/2	50
SH913	1/2 x 1-3/4	25
SH914	1/2 x 2"	25
SH915	1/2 x 2-1/4	25
SH916	1/2 x 2-1/2	25
SH917	1/2 x 3"	25
SH918	1/2 x 3-1/2	25
SH919	1/2 x 4"	25
SH9191	1/2 x 4-1/2	10
SH9192	1/2 x 5"	10

(CONTINUED NEXT COLUMN)

#### DOWEL PINS (CONT.)

STOCK NO.	SIZE	BOX QTY.
SH920	5/8 x 1"	10
SH921	5/8 x 1-1/4	10
SH922	5/8 x 1-1/2	10
SH924	5/8 x 2"	10
SH926	5/8 x 2-1/2	10
SH927	5/8 x 3"	10
SH928	5/8 x 3-1/2	10
SH929	5/8 x 4"	10
SH930	3/4 x 1"	10
SH932	3/4 x 1-1/2	10
SH934	3/4 x 2"	10
SH935	3/4 x 2-1/2	10
SH9355	3/4 x 2-3/4	10
SH936	3/4 x 3"	10
SH9365	3/4 x 3-1/4	10
SH937	3/4 x 3-1/2	10
SH938	3/4 x 4"	10
SH9387	3/4 x 6"	10
SH940	7/8 x 2"	-
SH944	1" x 3"	-
SH946	1" x 4"	-
SH9464	1" x 5"	-
SH9468	1" x 6"	-

#### PULL DOWEL PINS



STOCK NO.	SIZE	BOX QTY.
SH9539	5/16 x 1"	20
SH9547	3/8 x 1"	20
SH9548	3/8 x 1-1/4	20
SH9549	3/8 x 1-1/2	20
SH9551	3/8 x 2"	20
SH9555	1/2 x 1"	20
SH9556	1/2 x 1-1/4	20
SH9557	1/2 x 1-1/2	20
SH9558	1/2 x 1-3/4	20
SH9559	1/2 x 2"	20
SH9561	1/2 x 2-1/2	20
SH9563	1/2 x 3"	20
SH9567	5/8 x 1-1/4	10
SH9568	5/8 x 1-1/2	10
SH9570	5/8 x 2"	10
SH9572	5/8 x 2-1/2	10
-	5/8 x 3	-
SH9580	3/4 x 1-1/2	10
SH9582	3/4 x 2"	10
SH9584	3/4 x 2-1/2	10
SH9586	3/4 x 3"	10

ADDITIONAL SIZES AVAILABLE UPON REQUEST



**STAINLESS STEEL HEX NUTS**

**STAINLESS STEEL USS COARSE  
THREAD HEX NUTS**



STOCK NO.	SIZE	BOX QTY.
S000	2-56	100
0001*	4-40	100
S001	4-40	100
S0015	5-40	100
S002	6-32	100
S003	8-32	100
S0031*	8-32	100
S005	10-24	100
S0055	12-24	100
S006	1/4-20	100
S007	5/16-18	100
S008	3/8-16	100
S009	7/16-14	100
S010	1/2-13	100
S012	5/8-11	50
S013	3/4-10	25
S014	7/8-9	-
S015	1"-8	-
S0155	1-1/8-7	-
S016	1-1/4-7	-
0172	1-1/2-6	-
0176	1-3/4-5	-
0178	2"-4-1/2	-

\* SMALL PATTERN

**STAINLESS STEEL  
FINE THREAD HEX NUTS**



STOCK NO.	SIZE	BOX QTY.
S004	10-32	100
S019	1/4-28	100
S020	5/16-24	100
S021	3/8-24	100
0211	7/16-20	-
S0212	1/2-20	100
S0213	5/8-18	25
0214	3/4-16	-
0215	7/8-14	-
0216	1"-14	-
0217	1-1/8-12	-
0218	1-1/4-12	-
0219	1-1/2-12	-
022	2"-12	-

**STAINLESS STEEL  
ROD COUPLING NUTS**



STOCK NO.	USS COARSE THREAD		BOX QTY.
	SIZE	LENGTH	
S0304	1/4-20	x 7/8	25
0305	5/16-18	x 1-1/8	25
S0307	3/8-16	x 1-3/4	25
S0308	1/2-13	x 1-3/4	25
S0309	5/8-11	x 1-3/4	25
-	3/4-10	x 2-1/4	-

**STAINLESS STEEL USS COARSE  
THREAD HEX JAM NUTS**



STOCK NO.	SIZE	BOX QTY.
S0231	1/4-20	100
S0232	5/16-18	100
S0233	3/8-16	100
0234	7/16-14	-
S0235	1/2-13	100
S0236	5/8-11	50
S0237	3/4-10	25
0238	7/8-9	-
0239	1"-8	-
0240	1-1/8-7	-
0241	1-1/4-7	-
0242	1-1/2-6	-
0243	1-3/4-5	-
0244	2"-4-1/2	-

**STAINLESS STEEL USS FINE THREAD  
HEX JAM NUTS**



STOCK NO.	SIZE	BOX QTY.
0245	1/4-28	-
0246	5/16-24	-
0247	3/8-24	-
0248	7/16-20	-
0249	1/2-20	-
S02495	9/16-18	-
S0250	5/8-18	-
S0251	3/4-16	-
0252	7/8-14	-
0253	1"-14	-

**STAINLESS STEEL USS COARSE  
THREAD NYLON INSERT LOCKNUTS**



STOCK NO.	SIZE	BOX QTY.
034	2-56	-
0341	3-48	-
0342	4-40	-
0343	5-40	-
S035	6-32	100
S036	8-32	100
S038	10-24	100
S039	1/4-20	100
S040	5/16-18	100
S041	3/8-16	100
S042	7/16-14	100
S043	1/2-13	100
S0431	5/8-11	25
S0432	3/4-10	25
0433	7/8-9	-
0434	1"-8	-
0435	1-1/8-7	-
0436	1-1/4-7	-

**STAINLESS STEEL USS COARSE  
THREAD REVERSIBLE LOCKNUTS**



STOCK NO.	SIZE	BOX QTY.
S047	1/4-20	-
0471	5/16-18	-
S0472	3/8-16	-
0474	1/2-13	-

**STAINLESS STEEL FINE THREAD  
NYLON INSERT LOCKNUTS**



STOCK NO.	SIZE	BOX QTY.
S037	10-32	100
S0440	1/4-28	100
S0441	5/16-24	100
S0442	3/8-24	100
S0443	7/16-20	100
S0444	1/2-20	50
S0445	5/8-18	25
S0446	3/4-16	25
0447	7/8-14	-
0448	1"-14	-
0449	1-1/8-12	-
0450	1-1/4-12	-

**STAINLESS STEEL WING NUTS**



STOCK NO.	SIZE	BOX QTY.
050	6-32	-
051	8-32	-
052	10-24	-
053	10-32	-
S054	1/4-20	100
S055	5/16-18	100
S056	3/8-16	100
S057	1/2-13	25
058	5/8-11	-
059	3/4-10	-

**STAINLESS STEEL HEX CAP NUTS**



STOCK NO.	SIZE	BOX QTY.
0599	4-40	-
S060	6-32	100
S061	8-32	100
S062	10-24	100
063	10-32	-
S064	1/4-20	100
S065	5/16-18	100
S066	3/8-16	100
S067	1/2-13	50
068	5/8-11	-
069	3/4-10	-

**STAINLESS STEEL KEPS NUT**



STOCK NO.	SIZE	BOX QTY.
S0485	4-40	100
S0486	6-32	100
S0488	8-32	100
S0489	10-24	100
S04891	10-32	100
S0491	1/4-20	100

**ADDITIONAL SIZES AND NUTS AVAILABLE  
UPON REQUEST**

### STAINLESS STEEL WASHERS AND HEX HEAD CAP SCREWS

#### STAINLESS STEEL FLAT WASHERS



STOCK NO.	SIZE	BOX QTY.
S0695	#2	100
S0696	#3	100
S070	#4	100
0705	#5	-
S071	#6	100
S072	#8	100
S073	#10	100
S074	#12	100
S075	1/4	100
S076	5/16	100
S077	3/8 (7/8 OD)	100
S078	3/8 (1" OD)	100
S0785	7/16	100
S0788	1/2 (1-1/16 OD)	100
S079	1/2 (1-1/4 OD)	100
080	9/16	-
S081	5/8	50
S083	3/4	50
S084	7/8	25
S085	1"	25
086	1-1/8	-
087	1-1/4	-
088	1-1/2	-
089	1-3/4	-
090	2"	-

#### STAINLESS STEEL SPLIT LOCK WASHERS



STOCK NO.	SIZE	BOX QTY.
S0903	#2	100
0904	#3	-
S0905	#4	100
0906	#5	-
S091	#6	100
S092	#8	100
S093	#10	100
094	#12	-
S095	1/4	100
S096	5/16	100
S097	3/8	100
S098	7/16	100
S099	1/2	100
S101	5/8	100
S102	3/4	50
S103	7/8	25
S104	1"	25
105	1-1/8	-
106	1-1/4	-
107	1-1/2	-

#### STAINLESS BONDED WASHERS



STOCK NO.	SIZE	BOX QTY.
TEK54	3/16 (#10)	100
TEK56	1/4 (#14)	100
TEK561	5/16	50
TEK562	3/8	-

#### STAINLESS STEEL INTERNAL TOOTH LOCK WASHERS



STOCK NO.	SIZE	BOX QTY.
1073	#2	-
1074	#3	-
1075	#4	-
1076	#5	-
S1077	#6	100
S1078	#8	100
S1079	#10	100
1080	#12	-
S1081	1/4	100
S1082	5/16	100
S1083	3/8	100
1084	7/16	-
S1085	1/2	100
1086	5/8	-
1087	3/4	-

#### STAINLESS STEEL EXTERNAL TOOTH LOCK WASHERS

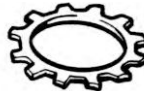

STOCK NO.	SIZE	BOX QTY.
1088	#2	100
1089	#3	100
S1090	#4	100
S1092	#6	100
S1093	#8	100
S1094	#10	100
1095	#12	100
S1096	1/4	100
S1097	5/16	100
S1098	3/8	100
1099	7/16	-
1100	1/2	-
1101	5/8	-

#### STAINLESS STEEL FINISHING WASHERS



STOCK NO.	SIZE	BOX QTY.
S1102	#6	100
S1103	#8	100
S1104	#10	100
1105	#12	-
S1106	1/4	100
1107	5/16	-

ADDITIONAL SIZES AND ITEMS AVAILABLE UPON REQUEST

#### STAINLESS STEEL FENDER WASHERS



STOCK NO.	SIZE	BOX QTY.
S1109	3/16 x 1"	100
S111	1/4 x 1"	100
S1113	1/4 x 1-1/4	100
S112	5/16 x 1-1/2	100
S113	3/8 x 1-1/2	100
114	3/8 x 2"	-
S115	1/2 x 2"	100

#### STAINLESS STEEL USS & SAE HEX HEAD CAP SCREWS



STOCK NO.	SIZE	BOX QTY.
S125	1/4-20 x 1/2	100
S1255	1/4-20 x 5/8	100
S126	1/4-20 x 3/4	100
1265	1/4-20 x 7/8	-
S127	1/4-20 x 1"	100
S128	1/4-20 x 1-1/4	100
S129	1/4-20 x 1-1/2	100
S130	1/4-20 x 1-3/4	100
S131	1/4-20 x 2"	100
S132	1/4-20 x 2-1/4	100
S133	1/4-20 x 2-1/2	100
1335	1/4-20 x 2-3/4	-
S134	1/4-20 x 3"	100
1345	1/4-20 x 3-1/4	-
S135	1/4-20 x 3-1/2	50
1355	1/4-20 x 3-3/4	-
S136	1/4-20 x 4"	50
1362	1/4-20 x 4-1/2	-
S1363	1/4-20 x 5"	-
1364	1/4-20 x 5-1/2	-
1365	1/4-20 x 6"	-
S2263	1/4-28 x 1/2	100
S2264	1/4-28 x 3/4	100
S2265	1/4-28 x 1"	100
S2266	1/4-28 x 1-1/4	50
S2267	1/4-28 x 1-1/2	50
S2268	1/4-28 x 2"	-

(CONTINUED NEXT PAGE)



**STAINLESS STEEL HEX HEAD CAP SCREWS AND TAP BOLTS**

STAINLESS STEEL HEX HEAD CAP SCREWS			
STOCK NO.	SIZE		BOX QTY.
S137	5/16-18 x 1/2		100
1375	5/16-18 x 5/8		-
S138	5/16-18 x 3/4		100
1385	5/16-18 x 7/8		-
S139	5/16-18 x 1"		100
S140	5/16-18 x 1-1/4		100
S141	5/16-18 x 1-1/2		100
S142	5/16-18 x 1-3/4		100
S143	5/16-18 x 2"		100
S144	5/16-18 x 2-1/4		50
S145	5/16-18 x 2-1/2		50
1455	5/16-18 x 2-3/4		-
S146	5/16-18 x 3"		-
1461	5/16-18 x 3-1/4		-
S1462	5/16-18 x 3-1/2		50
1463	5/16-18 x 3-3/4		-
S147	5/16-18 x 4"		50
1471	5/16-18 x 4-1/2		-
1472	5/16-18 x 5"		-
1473	5/16-18 x 5-1/2		-
1474	5/16-18 x 6"		-
S2278	5/16-24 x 3/4		100
S2280	5/16-24 x 1"		100
S2281	5/16-24 x 1-1/4		50
S2282	5/16-24 x 1-1/2		50
S2283	5/16-24 x 2"		50
S2284	5/16-24 x 2-1/4		50
S148	3/8-16 x 1/2		100
1485	3/8-16 x 5/8		-
S149	3/8-16 x 3/4		100
1495	3/8-16 x 7/8		-
S150	3/8-16 x 1"		100
S151	3/8-16 x 1-1/4		100
S152	3/8-16 x 1-1/2		100
S153	3/8-16 x 1-3/4		50
S154	3/8-16 x 2"		50
S155	3/8-16 x 2-1/4		50
S156	3/8-16 x 2-1/2		50
S157	3/8-16 x 2-3/4		50
S158	3/8-16 x 3"		50
1585	3/8-16 x 3-1/4		-
S159	3/8-16 x 3-1/2		25
1595	3/8-16 x 3-3/4		-
S160	3/8-16 x 4"		25
S1605	3/8-16 x 4-1/2		25
S161	3/8-16 x 5"		25
S1615	3/8-16 x 5-1/2		-
S162	3/8-16 x 6"		-
S2294	3/8-24 x 5/8		100
S2296	3/8-24 x 1"		100
S2297	3/8-24 x 1-1/4		50
S2298	3/8-24 x 1-1/2		50
S3000	3/8-24 x 2"		50
2315	7/16-14 x 1"		-
2316	7/16-14 x 1-1/4		-
2317	7/16-14 x 1-1/2		-

(CONTINUED)

STAINLESS STEEL HEX HEAD CAP SCREWS			
STOCK NO.	SIZE		BOX QTY.
S163	1/2-13 x 3/4		50
1635	1/2-13 x 7/8		-
S164	1/2-13 x 1"		50
S165	1/2-13 x 1-1/4		50
S166	1/2-13 x 1-1/2		50
S167	1/2-13 x 1-3/4		50
S168	1/2-13 x 2"		50
S169	1/2-13 x 2-1/4		25
S170	1/2-13 x 2-1/2		25
171	1/2-13 x 2-3/4		-
S172	1/2-13 x 3"		25
1725	1/2-13 x 3-1/4		-
S173	1/2-13 x 3-1/2		25
S1735	1/2-13 x 3-3/4		25
S174	1/2-13 x 4"		25
S175	1/2-13 x 4-1/2		25
S176	1/2-13 x 5"		25
177	1/2-13 x 5-1/2		-
S178	1/2-13 x 6"		25
S1783	1/2-13 x 7"		25
1784	1/2-13 x 8"		-
1786	1/2-13 x 9"		-
1794	5/8-11 x 1"		-
1795	5/8-11 x 1-1/4		-
S180	5/8-11 x 1-1/2		25
S181	5/8-11 x 1-3/4		25
S182	5/8-11 x 2"		25
183	5/8-11 x 2-1/4		-
S184	5/8-11 x 2-1/2		25
S185	5/8-11 x 2-3/4		25
S186	5/8-11 x 3"		25
1865	5/8-11 x 3-1/4		-
S187	5/8-11 x 3-1/2		25
1875	5/8-11 x 3-3/4		-
S188	5/8-11 x 4"		25
1885	5/8-11 x 4-1/2		-
S190	5/8-11 x 5"		-
191	5/8-11 x 5-1/2		-
S192	5/8-11 x 6"		-
S2352	5/8-18 x 2-1/2		-
193	3/4-10 x 1"		-
194	3/4-10 x 1-1/4		-
S195	3/4-10 x 1-1/2		25
S196	3/4-10 x 1-3/4		25
S197	3/4-10 x 2"		25
198	3/4-10 x 2-1/4		-
S199	3/4-10 x 2-1/2		25
200	3/4-10 x 2-3/4		-
S201	3/4-10 x 3"		-
2015	3/4-10 x 3-1/4		-
S202	3/4-10 x 3-1/2		-
2025	3/4-10 x 3-3/4		-
S203	3/4-10 x 4"		-
S204	3/4-10 x 4-1/2		-
S205	3/4-10 x 5"		-
S206	3/4-10 x 5-1/2		-
S207	3/4-10 x 6"		-

STAINLESS STEEL FULLY THREADED HEX HEAD TAP BOLT			
STOCK NO.	SIZE		BOX QTY.
S8500	1/4-20 x 1-1/4		100
S8501	1/4-20 x 1-1/2		100
S8502	1/4-20 x 1-3/4		100
S8503	1/4-20 x 2"		100
8504	1/4-20 x 2-1/4		-
S8505	1/4-20 x 2-1/2		50
8506	1/4-20 x 2-3/4		-
S8507	1/4-20 x 3"		50
8508	1/4-20 x 3-1/2		-
8509	1/4-20 x 4"		-
8510	1/4-20 x 4-1/2		-
8511	1/4-20 x 5"		-
8512	1/4-20 x 5-1/2		-
8513	1/4-20 x 6"		-
S8514	5/16-18 x 1-1/2		100
S8515	5/16-18 x 1-3/4		100
S8516	5/16-18 x 2"		100
8517	5/16-18 x 2-1/4		-
S8518	5/16-18 x 2-1/2		50
8519	5/16-18 x 2-3/4		-
S8520	5/16-18 x 3"		50
8521	5/16-18 x 3-1/2		-
8522	5/16-18 x 4"		-
8523	5/16-18 x 4-1/2		-
8524	5/16-18 x 5"		-
8525	5/16-18 x 5-1/2		-
8526	5/16-18 x 6"		-
S8527	3/8-16 x 1-1/2		100
S8528	3/8-16 x 1-3/4		50
S8529	3/8-16 x 2"		50
8530	3/8-16 x 2-1/4		-
S8531	3/8-16 x 2-1/2		50
8532	3/8-16 x 2-3/4		-
S8533	3/8-16 x 3"		50
S8534	3/8-16 x 3-1/2		25
S8535	3/8-16 x 4"		25
8536	3/8-16 x 4-1/2		-
8537	3/8-16 x 5"		-
8538	3/8-16 x 5-1/2		-
8539	3/8-16 x 6"		-
S8540	1/2-13 x 2"		-
8541	1/2-13 x 2-1/4		-
S8542	1/2-13 x 2-1/2		-
8543	1/2-13 x 2-3/4		-
S8544	1/2-13 x 3"		-
S8545	1/2-13 x 3-1/2		-
S8546	1/2-13 x 4"		-
S8547	1/2-13 x 4-1/2		-
S8548	1/2-13 x 5"		-
8549	1/2-13 x 5-1/2		-
S8550	1/2-13 x 6"		-



### STAINLESS STEEL SOCKET HEAD CAP SCREWS

#### STAINLESS STEEL SOCKET HEAD CAP SCREWS



STOCK NO.	SIZE	BOX QTY.
4537	4-40 x 3/16	-
<b>S4538</b>	4-40 x 1/4	100
4539	4-40 x 5/16	-
<b>S4540</b>	4-40 x 3/8	100
<b>S4541</b>	4-40 x 1/2	100
<b>S4542</b>	4-40 x 5/8	100
<b>S4543</b>	4-40 x 3/4	100
4544	4-40 x 7/8	-
<b>S4545</b>	4-40 x 1"	100
4546	4-40 x 1-1/4	-
<b>S4547</b>	6-32 x 1/4	100
4548	6-32 x 5/16	-
<b>S4549</b>	6-32 x 3/8	100
<b>S455</b>	6-32 x 1/2	100
<b>S456</b>	6-32 x 5/8	100
<b>S457</b>	6-32 x 3/4	100
4571	6-32 x 7/8	-
<b>S4572</b>	6-32 x 1"	100
<b>S4573</b>	6-32 x 1-1/4	100
<b>S4574</b>	6-32 x 1-1/2	100
4575	6-32 x 1-3/4	-
4576	6-32 x 2"	-
<b>S458</b>	8-32 x 3/16	100
<b>S459</b>	8-32 x 1/4	100
<b>S460</b>	8-32 x 3/8	100
<b>S461</b>	8-32 x 1/2	100
<b>S462</b>	8-32 x 5/8	100
<b>S463</b>	8-32 x 3/4	100
4635	8-32 x 7/8	-
<b>S464</b>	8-32 x 1"	100
4640	8-32 x 1-1/8	-
<b>S4641</b>	8-32 x 1-1/4	100
<b>S4642</b>	8-32 x 1-1/2	100
4643	8-32 x 1-3/4	-
<b>S4644</b>	8-32 x 2"	100
<b>S465</b>	10-24 x 3/8	100
<b>S466</b>	10-24 x 1/2	100
<b>S467</b>	10-24 x 5/8	100
<b>S468</b>	10-24 x 3/4	100
<b>S4685</b>	10-24 x 7/8	100
<b>S469</b>	10-24 x 1"	100
<b>S4691</b>	10-24 x 1-1/4	100
<b>S4692</b>	10-24 x 1-1/2	100
<b>S4693</b>	10-24 x 1-3/4	100
<b>S4694</b>	10-24 x 2"	100
4695	10-24 x 2-1/4	-
4696	10-24 x 2-1/2	-
<b>S4697</b>	10-24 x 3"	100

(CONTINUED)

#### STAINLESS STEEL SOCKET HEAD CAP SCREWS



STOCK NO.	SIZE	BOX QTY.
<b>S470</b>	10-32 x 3/8	100
<b>S4701</b>	10-32 x 1/2	100
<b>S4702</b>	10-32 x 5/8	100
<b>S4703</b>	10-32 x 3/4	100
4704	10-32 x 7/8	-
<b>S4705</b>	10-32 x 1"	100
<b>S4706</b>	10-32 x 1-1/4	100
<b>S4707</b>	10-32 x 1-1/2	100
4708	10-32 x 1-3/4	-
<b>S4709</b>	10-32 x 2"	100
4710	10-32 x 2-1/4	-
<b>S4711</b>	10-32 x 2-1/2	100
4712	10-32 x 3"	-
<b>S472</b>	1/4-20 x 3/8	100
<b>S473</b>	1/4-20 x 1/2	100
<b>S474</b>	1/4-20 x 5/8	100
<b>S475</b>	1/4-20 x 3/4	100
<b>S4755</b>	1/4-20 x 7/8	100
<b>S476</b>	1/4-20 x 1"	100
<b>S477</b>	1/4-20 x 1-1/4	100
<b>S478</b>	1/4-20 x 1-1/2	100
<b>S479</b>	1/4-20 x 1-3/4	100
<b>S480</b>	1/4-20 x 2"	100
<b>S481</b>	1/4-20 x 2-1/4	100
<b>S482</b>	1/4-20 x 2-1/2	100
<b>S4821</b>	1/4-20 x 2-3/4	50
<b>S483</b>	1/4-20 x 3"	50
<b>S4832</b>	1/4-20 x 3-1/2	50
<b>S4833</b>	1/4-20 x 4"	50
4834	1/4-20 x 4-1/2	-
<b>S4835</b>	1/4-20 x 5"	50
4836	1/4-20 x 5-1/2	-
484	5/16-18 x 3/8	-
<b>S4841</b>	5/16-18 x 1/2	100
4842	5/16-18 x 5/8	-
<b>S485</b>	5/16-18 x 3/4	100
4855	5/16-18 x 7/8	-
<b>S486</b>	5/16-18 x 1"	100
<b>S487</b>	5/16-18 x 1-1/4	100
<b>S488</b>	5/16-18 x 1-1/2	100
<b>S489</b>	5/16-18 x 1-3/4	100
<b>S490</b>	5/16-18 x 2"	50
4905	5/16-18 x 2-1/4	-
<b>S491</b>	5/16-18 x 2-1/2	50
<b>S4915</b>	5/16-18 x 3"	50
<b>S492</b>	3/8-16 x 1/2	100
493	3/8-16 x 5/8	-
<b>S494</b>	3/8-16 x 3/4	100
4945	3/8-16 x 7/8	-
<b>S495</b>	3/8-16 x 1"	100
<b>S496</b>	3/8-16 x 1-1/4	100
<b>S497</b>	3/8-16 x 1-1/2	100
<b>S498</b>	3/8-16 x 1-3/4	50
<b>S499</b>	3/8-16 x 2"	50
<b>S500</b>	3/8-16 x 2-1/4	50
<b>S501</b>	3/8-16 x 2-1/2	50
<b>S5015</b>	3/8-16 x 2-3/4	50
<b>S502</b>	3/8-16 x 3"	50
<b>S5022</b>	3/8-16 x 3-1/2	25
5024	3/8-16 x 4"	25
5025	3/8-16 x 4-1/2	-

(CONTINUED)

#### STAINLESS STEEL SOCKET HEAD CAP SCREWS



STOCK NO.	SIZE	BOX QTY.
503	1/2-13 x 3/4	-
5035	1/2-13 x 7/8	-
<b>S504</b>	1/2-13 x 1"	50
<b>S505</b>	1/2-13 x 1-1/4	50
<b>S506</b>	1/2-13 x 1-1/2	50
<b>S507</b>	1/2-13 x 1-3/4	50
<b>S508</b>	1/2-13 x 2"	50
509	1/2-13 x 2-1/4	-
<b>S510</b>	1/2-13 x 2-1/2	25
<b>S511</b>	1/2-13 x 3"	25
<b>S513</b>	1/2-13 x 3-1/2	25
<b>S5132</b>	1/2-13 x 4"	25
515	5/8-11 x 1"	-
5155	5/8-11 x 1-1/4	-
<b>S516</b>	5/8-11 x 1-1/2	25
5165	5/8-11 x 1-3/4	-
<b>S517</b>	5/8-11 x 2"	25
5175	5/8-11 x 2-1/4	-
518	5/8-11 x 2-1/2	-
<b>S519</b>	5/8-11 x 3"	25

QUALITY  
PRODUCTS  
FAIR  
AND  
COMPETITIVE  
PRICES  
AND  
EXCELLENT  
SERVICE  
IS OUR  
REPUTATION



**STAINLESS STEEL SOCKET CAP SCREWS**

**STAINLESS STEEL BUTTON HEAD SOCKET CAP SCREWS**



STOCK NO.	SIZE	BOX QTY.
745	4-40 x 1/8	-
7451	4-40 x 3/16	-
S7452	4-40 x 1/4	100
S7454	4-40 x 3/8	100
S7456	4-40 x 1/2	100
S7457	4-40 x 5/8	100
S7458	4-40 x 3/4	100
S7459	4-40 x 1"	100
7470	6-32 x 3/16	-
S7471	6-32 x 1/4	100
S7473	6-32 x 3/8	100
S7475	6-32 x 1/2	100
S7476	6-32 x 5/8	100
S7477	6-32 x 3/4	100
S7479	6-32 x 1"	100
S753	8-32 x 1/4	100
S755	8-32 x 3/8	100
S7551	8-32 x 1/2	100
7552	8-32 x 5/8	-
S7553	8-32 x 3/4	100
S7555	8-32 x 1"	100
S756	10-24 x 1/4	100
S7562	10-24 x 3/8	100
S757	10-24 x 1/2	100
S7574	10-24 x 5/8	100
S7575	10-24 x 3/4	100
S7576	10-24 x 7/8	100
S7577	10-24 x 1"	100
S7578	10-24 x 1-1/4	100
S7579	10-24 x 1-1/2	100
S7580	10-24 x 2"	25
S7582	10-24 x 2-1/2	-
S7590	10-32 x 1/4	100
S7592	10-32 x 3/8	100
S7594	10-32 x 1/2	100
S7595	10-32 x 5/8	100
S7596	10-32 x 3/4	100
S7598	10-32 x 1"	100
S75981	10-32 x 1-1/4	100
S75982	10-32 x 1-1/2	100
S75984	10-32 x 2"	100
S75986	10-32 x 2-1/2	-
S75988	10-32 x 3"	-
S760	1/4-20 x 3/8	100
S761	1/4-20 x 1/2	100
S762	1/4-20 x 5/8	100
S763	1/4-20 x 3/4	100
S7635	1/4-20 x 7/8	100
S764	1/4-20 x 1"	100
S765	1/4-20 x 1-1/4	100
S7651	1/4-20 x 1-1/2	100
S7653	1/4-20 x 2"	100
S7654	1/4-20 x 2-1/4	-
S7655	1/4-20 x 2-1/2	-
S7656	1/4-20 x 2-3/4	-
S7657	1/4-20 x 3"	-

(CONTINUED)

**STAINLESS STEEL BUTTON HEAD SOCKET CAP SCREWS**



STOCK NO.	SIZE	BOX QTY.
7660	5/16-18 x 3/8	-
S7662	5/16-18 x 1/2	100
S7663	5/16-18 x 5/8	100
S7664	5/16-18 x 3/4	100
S7666	5/16-18 x 1"	100
S7667	5/16-18 x 1-1/4	50
S7668	5/16-18 x 1-1/2	50
S7669	5/16-18 x 1-3/4	50
S76691	5/16-18 x 2"	50
S76692	5/16-18 x 2-1/2	-
S76694	5/16-18 x 3"	-
7670	3/8-16 x 1/2	-
S7672	3/8-16 x 3/4	50
S7674	3/8-16 x 1"	50
S7675	3/8-16 x 1-1/4	50
S7676	3/8-16 x 1-1/2	50
S76765	3/8-16 x 1-3/4	50
S7677	3/8-16 x 2"	50
S7678	3/8-16 x 2-1/4	-
S7679	3/8-16 x 2-1/2	-
S76791	3/8-16 x 3"	-

**STAINLESS STEEL FLAT HEAD SOCKET CAP SCREWS**



STOCK NO.	SIZE	BOX QTY.
S7710	4-40 x 1/4	100
S7712	4-40 x 3/8	100
S7713	4-40 x 1/2	100
S7715	4-40 x 3/4	100
S7716	4-40 x 1"	100
S7730	6-32 x 1/4	100
S7732	6-32 x 3/8	100
S7734	6-32 x 1/2	100
S7735	6-32 x 5/8	100
S7736	6-32 x 3/4	100
S7738	6-32 x 1"	100
S7739	6-32 x 1-1/4	100
7740	6-32 x 1-1/2	-
S7744	8-32 x 1/4	100
S7746	8-32 x 3/8	100
S7748	8-32 x 1/2	100
7749	8-32 x 5/8	-
S7750	8-32 x 3/4	100
S7751	8-32 x 7/8	100
S7752	8-32 x 1"	100
S7753	8-32 x 1-1/4	100
S7754	8-32 x 1-1/2	100

(CONTINUED)

**STAINLESS STEEL FLAT HEAD SOCKET CAP SCREWS**



STOCK NO.	SIZE	BOX QTY.
S7760	10-32 x 3/8	100
S7762	10-32 x 1/2	100
S7763	10-32 x 5/8	100
S7764	10-32 x 3/4	100
7765	10-32 x 7/8	-
S7766	10-32 x 1"	100
S7767	10-32 x 1-1/4	100
S7768	10-32 x 1-1/2	100
S785	10-24 x 3/8	100
S786	10-24 x 1/2	100
S7861	10-24 x 5/8	100
S7862	10-24 x 3/4	100
7863	10-24 x 7/8	-
S7864	10-24 x 1"	100
S7865	10-24 x 1-1/4	100
S7866	10-24 x 1-1/2	100
S787	1/4-20 x 3/8	100
S7872	1/4-20 x 1/2	100
S7874	1/4-20 x 5/8	100
S7876	1/4-20 x 3/4	100
7878	1/4-20 x 7/8	-
S788	1/4-20 x 1"	100
S7882	1/4-20 x 1-1/4	100
S7884	1/4-20 x 1-1/2	100
7886	1/4-20 x 1-3/4	-
S7888	1/4-20 x 2"	100
7889	1/4-20 x 2-1/4	-
7890	1/4-20 x 2-1/2	-
7891	5/16-18 x 5/8	-
S7892	5/16-18 x 3/4	100
S7893	5/16-18 x 1"	100
S7894	5/16-18 x 1-1/4	100
S7895	5/16-18 x 1-1/2	100
7896	5/16-18 x 1-3/4	-
S7897	5/16-18 x 2"	50
S790	5/16-18 x 2-1/2	50
7905	5/16-18 x 3"	-
791	3/8-16 x 1/2	-
7915	3/8-16 x 5/8	-
S792	3/8-16 x 3/4	100
S7925	3/8-16 x 1"	100
S793	3/8-16 x 1-1/4	50
S794	3/8-16 x 1-1/2	50
S7942	3/8-16 x 1-3/4	50
S7944	3/8-16 x 2"	50
7946	3/8-16 x 2-1/4	-
S795	3/8-16 x 2-1/2	50
S796	3/8-16 x 3"	50
S797	3/8-16 x 3-1/2	50
7970	1/2-13 x 3/4	-
7971	1/2-13 x 1"	-
S7972	1/2-13 x 1-1/4	25
S7973	1/2-13 x 1-1/2	25
7974	1/2-13 x 1-3/4	-
S7975	1/2-13 x 2"	25
7976	1/2-13 x 2-1/2	-
7977	1/2-13 x 3"	-

**ADDITIONAL SIZES AVAILABLE UPON REQUEST**

### STAINLESS STEEL SET SCREWS AND LAG SCREWS

#### STAINLESS STEEL SOCKET SET SCREWS



STOCK NO.	SIZE DIA.	x	LGTH.	BOX QTY.
S535	6-32	x	3/16	100
S536	6-32	x	1/4	100
S5362	6-32	x	3/8	100
S5364	6-32	x	1/2	100
5366	6-32	x	3/4	-
5367	6-32	x	1"	-
S539	8-32	x	1/8	100
S5397	8-32	x	3/16	100
S5398	8-32	x	1/4	100
S540	8-32	x	3/8	100
S541	8-32	x	1/2	100
542	8-32	x	5/8	-
S543	8-32	x	3/4	100
S5432	8-32	x	1"	100
S5433	8-32	x	1-1/4	100
544	10-24	x	1/8	-
5445	10-24	x	3/16	-
S545	10-24	x	1/4	100
5455	10-24	x	5/16	-
S546	10-24	x	3/8	100
S547	10-24	x	1/2	100
S548	10-24	x	3/4	100
5482	10-24	x	1"	-
5483	10-24	x	1-1/4	-
5484	10-24	x	1-1/2	-
S5488	10-32	x	1/8	100
S5489	10-32	x	3/16	100
S549	10-32	x	1/4	100
5495	10-32	x	5/16	-
S550	10-32	x	3/8	100
S551	10-32	x	1/2	100
5511	10-32	x	5/8	-
S5512	10-32	x	3/4	100
S5514	10-32	x	1"	100
5515	10-32	x	1-1/4	-
S552	1/4-20	x	3/16	100
S553	1/4-20	x	1/4	100
5535	1/4-20	x	5/16	-
S554	1/4-20	x	3/8	100
S555	1/4-20	x	1/2	100
S5552	1/4-20	x	3/4	100
S5554	1/4-20	x	1"	100
5555	1/4-20	x	1-1/4	-
S5556	1/4-20	x	1-1/2	100
5558	1/4-20	x	2"	-
566	1/4-28	x	3/16	-
S5561	1/4-28	x	1/4	100
S5563	1/4-28	x	3/8	100
5565	1/4-28	x	1/2	-
5566	1/4-28	x	3/4	-
5569	1/4-28	x	1"	-
5571	1/4-28	x	1-1/2	-
S558	5/16-18	x	1/4	100
5585	5/16-18	x	5/16	-
S559	5/16-18	x	3/8	100
S560	5/16-18	x	1/2	100
S5601	5/16-18	x	5/8	100
S5602	5/16-18	x	3/4	50
S5604	5/16-18	x	1"	50
S5605	5/16-18	x	1-1/4	50
5606	5/16-18	x	1-1/2	-
5607	5/16-18	x	2"	-

(CONTINUED)

#### STAINLESS STEEL SOCKET SET SCREWS



STOCK NO.	SIZE DIA.	x	LGTH.	BOX QTY.
5608	5/16-24	x	1/4	-
561	5/16-24	x	3/8	-
5611	5/16-24	x	1/2	-
5613	5/16-24	x	3/4	-
5614	5/16-24	x	1"	-
S563	3/8-16	x	1/4	100
5635	3/8-16	x	5/16	-
S564	3/8-16	x	3/8	100
S565	3/8-16	x	1/2	100
S5652	3/8-16	x	3/4	100
S5654	3/8-16	x	1"	50
S5655	3/8-16	x	1-1/4	50
5656	3/8-16	x	1-1/2	-
5658	3/8-16	x	2"	-
5661	3/8-24	x	1/4	-
5663	3/8-24	x	3/8	-
5664	3/8-24	x	1/2	-
5666	3/8-24	x	3/4	-
S5668	3/8-24	x	1"	100
S570	1/2-13	x	3/8	100
S5705	1/2-13	x	1/2	50
S5707	1/2-13	x	5/8	50
S571	1/2-13	x	3/4	50
S572	1/2-13	x	1"	50
S573	1/2-13	x	1-1/2	50
S574	1/2-13	x	2"	50
S575	5/8-11	x	1/2	50
5751	5/8-11	x	5/8	-
5752	5/8-11	x	3/4	-
5750	5/8-11	x	1"	-
5755	5/8-11	x	1-1/4	-
5756	5/8-11	x	1-1/2	-

ADDITIONAL SIZES AVAILABLE UPON REQUEST

#### STAINLESS STEEL LAG SCREWS



STOCK NO.	SIZE DIA.	x	LGTH.	BOX QTY.
S8025	1/4	x	1"	100
S8026	1/4	x	1-1/4	100
S8027	1/4	x	1-1/2	100
S8028	1/4	x	2"	100
S8029	1/4	x	2-1/2	100
S8030	1/4	x	3"	100
8031	1/4	x	3-1/2	-
8032	1/4	x	4"	-
8033	1/4	x	4-1/2	-
8034	1/4	x	5"	-
8035	1/4	x	5-1/2	-
8036	1/4	x	6"	-
8037	5/16	x	1"	-
8038	5/16	x	1-1/4	-
8039	5/16	x	1-1/2	-
8040	5/16	x	2"	-
8041	5/16	x	2-1/2	-
8042	5/16	x	3"	-
8044	5/16	x	3-1/2	-
8045	5/16	x	4"	-
8046	5/16	x	4-1/2	-
8047	5/16	x	5"	-
8048	5/16	x	6"	-
8048	3/8	x	1"	-
S8049	3/8	x	1-1/4	100
S8050	3/8	x	1-1/2	100
8051	3/8	x	1-3/4	-
S8052	3/8	x	2"	50
S8053	3/8	x	2-1/2	50
S8054	3/8	x	3"	50
S8055	3/8	x	3-1/2	50
S8056	3/8	x	4"	50
8057	3/8	x	4-1/2	-
8058	3/8	x	5"	-
8059	3/8	x	5-1/2	-
8060	3/8	x	6"	-
80609	1/2	x	1-1/4	-
8061	1/2	x	1-1/2	-
80615	1/2	x	1-3/4	-
S8062	1/2	x	2"	25
8063	1/2	x	2-1/2	-
8064	1/2	x	3"	-
8065	1/2	x	3-1/2	-
8066	1/2	x	4"	-

ADDITIONAL SIZES AVAILABLE UPON REQUEST



## YOUR COMPLETE SOURCE FOR INDUSTRIAL SUPPLIES

**STAINLESS STEEL CARRIAGE BOLTS, COTTER AND SPRING PINS**

**STAINLESS STEEL CARRIAGE BOLTS**

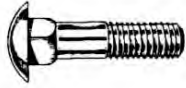

STOCK NO.	SIZE	BOX QTY.
S8092	10-24 x 3/4	100
S8093	10-24 x 1"	100
S8095	10-24 x 1-1/2	100
S8096	10-24 x 2"	100
8100	1/4-20 x 1/2	-
S8102	1/4-20 x 3/4	100
S8103	1/4-20 x 1"	100
S8104	1/4-20 x 1-1/4	100
S8105	1/4-20 x 1-1/2	100
8106	1/4-20 x 1-3/4	-
S8107	1/4-20 x 2"	100
8108	1/4-20 x 2-1/4	-
S8109	1/4-20 x 2-1/2	50
81095	1/4-20 x 2-3/4	-
S8110	1/4-20 x 3"	50
S8111	1/4-20 x 3-1/2	50
S8112	1/4-20 x 4"	50
S8113	1/4-20 x 4-1/2	50
8114	1/4-20 x 5"	-
8115	1/4-20 x 5-1/2	-
8116	1/4-20 x 6"	-
S8117	5/16-18 x 3/4	100
S8118	5/16-18 x 1"	100
S8119	5/16-18 x 1-1/4	100
S8120	5/16-18 x 1-1/2	100
8121	5/16-18 x 1-3/4	-
S8122	5/16-18 x 2"	100
S8123	5/16-18 x 2-1/2	50
S8124	5/16-18 x 3"	50
8125	5/16-18 x 3-1/2	-
8126	5/16-18 x 4"	-
8127	5/16-18 x 5"	-
8128	5/16-18 x 6"	-
8129	3/8-16 x 3/4	-
8130	3/8-16 x 1"	-
S8131	3/8-16 x 1-1/4	50
S8132	3/8-16 x 1-1/2	50
8133	3/8-16 x 1-3/4	-
S8134	3/8-16 x 2"	50
8135	3/8-16 x 2-1/4	-
S8136	3/8-16 x 2-1/2	25
S8137	3/8-16 x 3"	25
S8138	3/8-16 x 3-1/2	25
S8139	3/8-16 x 4"	25
S8140	3/8-16 x 4-1/2	25
S8141	3/8-16 x 5"	25
S8142	3/8-16 x 5-1/2	25
S8143	3/8-16 x 6"	25
8144	1/2-13 x 1"	-
8145	1/2-13 x 1-1/4	-
S8146	1/2-13 x 1-1/2	50
8147	1/2-13 x 1-3/4	-
8148	1/2-13 x 2"	-
8150	1/2-13 x 2-1/2	-
8151	1/2-13 x 3"	-
8152	1/2-13 x 3-1/2	-
8153	1/2-13 x 4"	-
8154	1/2-13 x 4-1/2	-
8155	1/2-13 x 5"	-
8156	1/2-13 x 5-1/2	-
8157	1/2-13 x 6"	-

ADDITIONAL SIZES AVAILABLE UPON REQUEST

**STAINLESS STEEL COTTER PINS**



STOCK NO.	DIA.	x	LGTH.	BOX QTY.
S8203	1/16	x	1/2	100
S8205	1/16	x	3/4	100
S8206	1/16	x	1"	100
S8207	1/16	x	1-1/4	100
S8208	1/16	x	1-1/2	100
S8210	1/16	x	2"	100
S8226	3/32	x	3/4	100
S8227	3/32	x	1"	100
S8229	3/32	x	1-1/2	100
S8231	3/32	x	2"	100
S8244	1/8	x	3/4	100
S8245	1/8	x	1"	100
S8246	1/8	x	1-1/4	100
S8247	1/8	x	1-1/2	100
S8249	1/8	x	2"	100
S8251	1/8	x	2-1/2	100
S8252	1/8	x	3"	100
8258	5/32	x	1"	-
S8260	5/32	x	1-1/2	100
S8262	5/32	x	2"	100
S8263	5/32	x	2-1/2	100
S8268	3/16	x	1"	100
8269	3/16	x	1-1/4	-
S8270	3/16	x	1-1/2	100
S8272	3/16	x	2"	100
S8274	3/16	x	2-1/2	100
S8275	3/16	x	3"	50
S8278	1/4	x	1"	50
8279	1/4	x	1-1/4	-
8280	1/4	x	1-1/2	-
8282	1/4	x	2"	-
S8284	1/4	x	2-1/2	50
8285	1/4	x	3"	-
8287	1/4	x	4"	-
S8294	5/16	x	2"	-
8297	5/16	x	3"	-

ADDITIONAL SIZES AVAILABLE UPON REQUEST

CALL AND  
SEE HOW  
WE  
MAKE  
THE  
DIFFERENCE!!

**STAINLESS STEEL SPRING PINS**



STOCK NO.	DIA.	x	LGTH.	BOX QTY.
S8322	1/16	x	1/2	100
S8341	3/32	x	3/8	100
S8342	3/32	x	1/2	100
S8343	3/32	x	3/4	100
S8344	3/32	x	1"	100
S8352	1/8	x	3/4	100
S8353	1/8	x	1"	100
S8354	1/8	x	1-1/4	100
S8355	1/8	x	1-1/2	100
S8356	1/8	x	2"	100
8363	5/32	x	1"	-
8364	5/32	x	1-1/4	-
8365	5/32	x	1-1/2	-
8367	5/32	x	2"	-
S8375	3/16	x	1"	100
S8376	3/16	x	1-1/2	100
S8379	3/16	x	2"	100
S8392	1/4	x	1"	100
S8396	1/4	x	1-1/2	100
S8397	1/4	x	2"	100
S8400	1/4	x	2-1/2	100

ADDITIONAL SIZES AVAILABLE UPON REQUEST

**ASSISTANCE**  
**IS**  
**A**  
  
**PHONE**  
**CALL**  
**AWAY!**

CALL US FOR ALL YOUR NEEDS  
**855-785-TOOL**

## STAINLESS STEEL DOWEL PINS AND SHEET METAL SCREWS

### STAINLESS STEEL DOWEL PINS



STOCK NO.	SIZE	BOX QTY.
NO.	DIA. x LGTH.	QTY.
<b>S5829</b>	3-32 x 3/8	100
5841	1/8 x 3/16	-
5842	1/8 x 1/4	-
<b>S5844</b>	1/8 x 3/8	100
<b>S5846</b>	1/8 x 1/2	100
<b>S5848</b>	1/8 x 3/4	100
<b>S5849</b>	1/8 x 1"	100
<b>S5850</b>	1/8 x 1-1/4	100
<b>S5851</b>	1/8 x 1-1/2	100
<b>S5855</b>	5/32 x 1/2	100
5860	3/16 x 3/8	-
<b>S5861</b>	3/16 x 1/2	100
5863	3/16 x 3/4	-
58635	3/16 x 7/8	-
<b>S5864</b>	3/16 x 1"	100
<b>S5866</b>	3/16 x 1-1/2	100
<b>S5875</b>	1/4 x 3/8	100
<b>S58755</b>	1/4 x 1/2	100
<b>S5880</b>	1/4 x 3/4	100
58805	1/4 x 7/8	-
<b>S5881</b>	1/4 x 1"	100
<b>S58815</b>	1/4 x 1-1/4	100
<b>S5882</b>	1/4 x 1-1/2	100
<b>S58825</b>	1/4 x 1-3/4	100
<b>S5883</b>	1/4 x 2"	100
5890	5/16 x 1"	-
<b>S5891</b>	5/16 x 1-1/4	50
5892	5/16 x 1-1/2	-
5894	5/16 x 2"	-
5896	3/8 x 3/4	-
<b>S5898</b>	3/8 x 1"	50
<b>S5899</b>	3/8 x 1-1/4	50
<b>S5900</b>	3/8 x 1-1/2	50
<b>S5901</b>	3/8 x 2"	50

ADDITIONAL SIZES AVAILABLE UPON REQUEST



**ANYTHING ELSE  
YOU NEED?  
PLEASE LET US KNOW!!**

### STAINLESS STEEL SLOTTED PAN HEAD SHEET METAL SCREWS

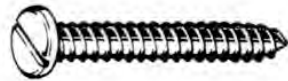

STOCK NO.	SIZE	BOX QTY.
<b>S596</b>	4 x 1/4	100
597	4 x 3/8	-
598	4 x 1/2	-
599	4 x 5/8	-
600	4 x 3/4	-
601	4 x 1"	-
602	6 x 1/4	-
<b>S603</b>	6 x 3/8	100
<b>S604</b>	6 x 1/2	100
605	6 x 5/8	-
<b>S606</b>	6 x 3/4	100
6065	6 x 7/8	-
<b>S607</b>	6 x 1"	100
608	6 x 1-1/4	-
609	6 x 1-1/2	-
6091	6 x 1-3/4	-
6092	6 x 2"	-
<b>S610</b>	8 x 3/8	100
<b>S611</b>	8 x 1/2	100
<b>S612</b>	8 x 5/8	100
<b>S613</b>	8 x 3/4	100
6135	8 x 7/8	-
<b>S614</b>	8 x 1"	100
<b>S615</b>	8 x 1-1/4	100
<b>S616</b>	8 x 1-1/2	100
617	8 x 1-3/4	-
<b>S618</b>	8 x 2"	100
620	10 x 3/8	-
<b>S622</b>	10 x 1/2	100
623	10 x 5/8	-
<b>S624</b>	10 x 3/4	100
6245	10 x 7/8	-
<b>S625</b>	10 x 1"	100
<b>S626</b>	10 x 1-1/4	100
<b>S627</b>	10 x 1-1/2	100
628	10 x 1-3/4	-
<b>S629</b>	10 x 2"	100
<b>S633</b>	12 x 1/2	100
634	12 x 5/8	-
<b>S635</b>	12 x 3/4	100
<b>S637</b>	12 x 1"	100
638	12 x 1-1/4	-
639	12 x 1-1/2	-
6391	12 x 1-3/4	-
6392	12 x 2"	-
640	14 x 1/2	-
641	14 x 5/8	-
642	14 x 3/4	-
<b>S643</b>	14 x 1"	100
<b>S644</b>	14 x 1-1/4	100
645	14 x 1-1/2	-
646	14 x 1-3/4	-
647	14 x 2"	-

ADDITIONAL SIZES AVAILABLE UPON REQUEST

### STAINLESS STEEL PHILLIPS PAN HEAD SHEET METAL SCREWS



STOCK NO.	SIZE	BOX QTY.
<b>S651</b>	4 x 1/4	100
<b>S652</b>	4 x 3/8	100
<b>S653</b>	4 x 1/2	100
<b>S6531</b>	4 x 3/4	100
6533	4 x 1"	-
<b>S654</b>	6 x 1/4	100
<b>S655</b>	6 x 3/8	100
<b>S656</b>	6 x 1/2	100
6566	6 x 5/8	-
<b>S6567</b>	6 x 3/4	100
<b>S6568</b>	6 x 1"	100
<b>S65681</b>	6 x 1-1/4	100
<b>S65682</b>	6 x 1-1/2	100
<b>S65683</b>	6 x 1-3/4	100
65689	8 x 1/4	-
<b>S6569</b>	8 x 3/8	100
<b>S657</b>	8 x 1/2	100
<b>S6575</b>	8 x 5/8	100
<b>S658</b>	8 x 3/4	100
<b>S659</b>	8 x 1"	100
<b>S660</b>	8 x 1-1/4	100
<b>S661</b>	8 x 1-1/2	100
<b>S6612</b>	8 x 1-3/4	100
<b>S6613</b>	8 x 2"	100
<b>S6614</b>	8 x 2-1/2	100
<b>S6615</b>	8 x 3"	100
<b>S6619</b>	10 x 3/8	100
<b>S662</b>	10 x 1/2	100
6625	10 x 5/8	-
<b>S663</b>	10 x 3/4	100
<b>S664</b>	10 x 1"	100
<b>S6645</b>	10 x 1-1/4	100
<b>S665</b>	10 x 1-1/2	100
<b>S6656</b>	10 x 1-3/4	100
<b>S666</b>	10 x 2"	100
<b>S667</b>	10 x 2-1/2	100
<b>S668</b>	10 x 3"	100
<b>S669</b>	12 x 1/2	100
6691	12 x 5/8	-
<b>S6692</b>	12 x 3/4	100
<b>S6693</b>	12 x 1"	100
<b>S6694</b>	12 x 1-1/4	100
<b>S6695</b>	12 x 1-1/2	100
<b>S6696</b>	12 x 1-3/4	100
<b>S6697</b>	12 x 2"	100
<b>S6698</b>	12 x 2-1/2	100
<b>S6699</b>	12 x 3"	100
<b>S670</b>	14 x 1/2	100
6701	14 x 5/8	-
<b>S6702</b>	14 x 3/4	100
<b>S6703</b>	14 x 1"	100
<b>S6704</b>	14 x 1-1/4	100
<b>S6705</b>	14 x 1-1/2	100
<b>S6706</b>	14 x 1-3/4	100
<b>S6707</b>	14 x 2"	100
<b>S6708</b>	14 x 2-1/2	100
<b>S6709</b>	14 x 3"	100

ADDITIONAL SIZES AVAILABLE UPON REQUEST



**STAINLESS STEEL SHEET METAL SCREWS AND MACHINE SCREWS**

**STAINLESS STEEL SLOTTED HEX  
HEAD SHEET METAL SCREWS**



STOCK NO.	SIZE	BOX QTY.
S672	6 x 1/4	100
S6721	6 x 3/8	100
S6722	6 x 1/2	100
S673	6 x 5/8	100
S6731	6 x 3/4	100
S674	6 x 1"	100
S676	8 x 3/8	100
S677	8 x 1/2	100
S678	8 x 5/8	100
S679	8 x 3/4	100
6791	8 x 7/8	-
S6792	8 x 1"	100
S6793	8 x 1-1/4	100
S6794	8 x 1-1/2	100
S6795	8 x 1-3/4	100
S6796	8 x 2"	100
S6800	10 x 3/8	100
S6801	10 x 1/2	100
S6802	10 x 5/8	100
S6803	10 x 3/4	100
S6805	10 x 1"	100
S6806	10 x 1-1/4	100
S6807	10 x 1-1/2	100
S6808	10 x 1-3/4	100
S6809	10 x 2"	100
6820	12 x 1/2	-
S6822	12 x 3/4	100
S6824	12 x 1"	100
S6825	12 x 1-1/4	100
S6826	12 x 1-1/2	100
6828	12 x 2"	-
6840	14 x 1/2	-
S6842	14 x 3/4	100
S6844	14 x 1"	100
S6846	14 x 1-1/2	100
S6848	14 x 2"	100
S6849	14 x 2-1/2	100
S6850	14 x 3"	100

**STAINLESS STEEL PHILLIPS FLAT  
HEAD SHEET METAL SCREWS**



STOCK NO.	SIZE	BOX QTY.
S6880	6 x 1/2	100
S6882	6 x 3/4	100
S6883	6 x 1"	100
S6886	8 x 1/2	100
S6887	8 x 3/4	100
S6888	8 x 1"	100
S6889	8 x 1-1/4	-
S6890	8 x 1-1/2	100
S6892	8 x 2"	100

(CONTINUED)

**STAINLESS STEEL PHILLIPS FLAT  
HEAD SHEET METAL SCREWS**



STOCK NO.	SIZE	BOX QTY.
S6896	10 x 3/4	100
S6897	10 x 1"	100
S6898	10 x 1-1/4	100
S6899	10 x 1-1/2	100
690	10 x 1-3/4	-
S6901	10 x 2"	100
6903	10 x 2-1/2	-
6904	10 x 3"	-
S6910	12 x 1-1/2	100
S6911	12 x 2"	100
S6913	12 x 2-1/2	100
S69131	12 x 3"	100
S69132	12 x 3-1/2	100
S6914	14 x 3/4	100
S6915	14 x 1"	100
S6916	14 x 1-1/4	100
S6917	14 x 1-1/2	100
S6919	14 x 2"	100
S6920	14 x 2-1/2	100

**STAINLESS STEEL PHILLIPS OVAL  
HEAD SHEET METAL SCREWS**

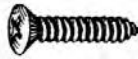

STOCK NO.	SIZE	BOX QTY.
S6930	6 x 3/8	100
S6931	6 x 1/2	100
S6932	6 x 5/8	100
S6933	6 x 3/4	100
S6934	6 x 1"	100
S6935	6 x 1-1/4	100
S6936	6 x 1-1/2	100
6938	6 x 2"	-
6939	8 x 3/8	-
S6940	8 x 1/2	100
S6942	8 x 3/4	100
S6943	8 x 1"	100
S6944	8 x 1-1/4	100
S6945	8 x 1-1/2	100
S6947	8 x 2"	100
S6948	10 x 1/2	100
S6950	10 x 3/4	100
S6951	10 x 1"	100
S6952	10 x 1-1/4	100
S6953	10 x 1-1/2	100
S6954	10 x 1-3/4	100
S6955	10 x 2"	100
S6959	12 x 3/4	100
S6960	12 x 1"	100
S6961	12 x 1-1/4	100
S6962	12 x 1-1/2	100
S6964	12 x 2"	100
S6971	14 x 1-1/2	-

**ADDITIONAL SIZES AND ITEMS  
AVAILABLE UPON REQUEST**

**STAINLESS STEEL SLOTTED ROUND  
HEAD MACHINE SCREWS**



STOCK NO.	SIZE	BOX QTY.
244	4-40 x 1/8	-
245	4-40 x 3/16	-
S246	4-40 x 1/4	100
247	4-40 x 3/8	-
S248	4-40 x 1/2	100
S249	4-40 x 3/4	100
S2492	4-40 x 1"	100
2493	4-40 x 1-1/4	-
2494	4-40 x 1-1/2	-
S250	5-40 x 1/2	100
251	5-40 x 3/4	-
S254	6-32 x 3/16	100
S255	6-32 x 1/4	100
2555	6-32 x 5/16	-
S256	6-32 x 3/8	100
S257	6-32 x 1/2	100
2575	6-32 x 5/8	-
S258	6-32 x 3/4	100
2585	6-32 x 7/8	-
S259	6-32 x 1"	100
2591	6-32 x 1-1/4	-
S2592	6-32 x 1-1/2	100
2593	6-32 x 1-3/4	-
2594	6-32 x 2"	-
2596	6-32 x 2-1/2	-
S260	8-32 x 3/16	100
S2602	8-32 x 1/4	100
2604	8-32 x 5/16	-
S2606	8-32 x 3/8	100
S261	8-32 x 1/2	100
S262	8-32 x 5/8	100
S263	8-32 x 3/4	100
S264	8-32 x 1"	100
S265	8-32 x 1-1/4	100
S266	8-32 x 1-1/2	100
267	8-32 x 1-3/4	-
S268	8-32 x 2"	100
2681	8-32 x 2-1/4	-
S2682	8-32 x 2-1/2	100
S2683	8-32 x 3"	100
269	10-24 x 1/4	-
270	10-24 x 5/16	-
S271	10-24 x 3/8	100
S272	10-24 x 1/2	100
273	10-24 x 5/8	-
S274	10-24 x 3/4	100
S275	10-24 x 1"	100
S276	10-24 x 1-1/4	100
S277	10-24 x 1-1/2	100
278	10-24 x 1-3/4	-
S279	10-24 x 2"	100
280	10-24 x 2-1/4	-
S281	10-24 x 2-1/2	100
S282	10-24 x 3"	100

(CONTINUED NEXT PAGE)

"THE NATIONAL PASTIME OF TAHITI IS MAKING LOVE," SAYS BOB HOPE. "BUT WE SILLY FOOLS PICKED BASEBALL."

## STAINLESS STEEL MACHINE SCREWS

### STAINLESS STEEL SLOTTED ROUND HEAD MACHINE SCREWS



STOCK NO.	SIZE	BOX QTY.
2828	10-32 x 1/4	-
<b>S283</b>	10-32 x 3/8	100
<b>S284</b>	10-32 x 1/2	100
285	10-32 x 5/8	-
<b>S286</b>	10-32 x 3/4	100
2865	10-32 x 7/8	-
<b>S287</b>	10-32 x 1"	100
<b>S288</b>	10-32 x 1-1/4	100
<b>S289</b>	10-32 x 1-1/2	100
2895	10-32 x 1-3/4	-
<b>S290</b>	10-32 x 2"	100
291	10-32 x 2-1/4	-
292	10-32 x 2-1/2	-
293	10-32 x 3"	-
294	1/4-20 x 3/8	-
<b>S295</b>	1/4-20 x 1/2	100
2955	1/4-20 x 5/8	-
<b>S296</b>	1/4-20 x 3/4	100
2965	1/4-20 x 7/8	-
<b>S297</b>	1/4-20 x 1"	100
<b>S298</b>	1/4-20 x 1-1/4	100
<b>S299</b>	1/4-20 x 1-1/2	100
300	1/4-20 x 1-3/4	-
<b>S301</b>	1/4-20 x 2"	100
302	1/4-20 x 2-1/4	-
<b>S303</b>	1/4-20 x 2-1/2	100
<b>S304</b>	1/4-20 x 3"	100
<b>S305</b>	1/4-20 x 3-1/2	100
<b>S306</b>	1/4-20 x 4"	50
307	5/16-18 x 1/2	-
3075	5/16-18 x 3/4	-
308	5/16-18 x 1"	-
3082	5/16-18 x 1-1/4	-
3085	5/16-18 x 1-1/2	-
3087	5/16-18 x 1-3/4	-
309	5/16-18 x 2"	-
3091	5/16-18 x 2-1/4	-
3092	5/16-18 x 2-1/2	-
3093	5/16-18 x 3"	-
<b>S3095</b>	5/16-18 x 4"	25
310	3/8-16 x 1/2	-
3105	3/8-16 x 3/4	-
311	3/8-16 x 1"	-
3112	3/8-16 x 1-1/4	-
3113	3/8-16 x 1-1/2	-
3114	3/8-16 x 1-3/4	-
3115	3/8-16 x 2"	-
3116	3/8-16 x 2-1/4	-
3117	3/8-16 x 2-1/2	-
3118	3/8-16 x 3"	-
<b>S312</b>	3/8-16 x 4"	25

**ADDITIONAL SIZES AND ITEMS  
AVAILABLE UPON REQUEST**

### STAINLESS STEEL SLOTTED FLAT HEAD MACHINE SCREWS



STOCK NO.	SIZE	BOX QTY.
319	6-32 x 3/16	-
<b>S320</b>	6-32 x 1/4	100
<b>S321</b>	6-32 x 3/8	100
<b>S323</b>	6-32 x 1/2	100
3235	6-32 x 5/8	-
<b>S324</b>	6-32 x 3/4	100
325	6-32 x 7/8	-
<b>S326</b>	6-32 x 1"	100
327	6-32 x 1-1/4	-
<b>S328</b>	6-32 x 1-1/2	100
3281	6-32 x 1-3/4	-
3282	6-32 x 2"	-
3288	8-32 x 1/4	-
<b>S329</b>	8-32 x 3/8	100
<b>S330</b>	8-32 x 1/2	100
331	8-32 x 5/8	-
<b>S333</b>	8-32 x 3/4	100
3335	8-32 x 7/8	-
<b>S334</b>	8-32 x 1"	100
3345	8-32 x 1-1/4	-
335	8-32 x 1-1/2	-
3355	8-32 x 1-3/4	-
336	8-32 x 2"	-
3365	8-32 x 2-1/4	-
337	8-32 x 2-1/2	-
3375	8-32 x 3"	-
338	10-32 x 1/4	-
<b>S340</b>	10-32 x 3/8	100
<b>S341</b>	10-32 x 1/2	100
<b>S342</b>	10-32 x 5/8	100
<b>S343</b>	10-32 x 3/4	100
3435	10-32 x 7/8	-
<b>S344</b>	10-32 x 1"	100
<b>S3445</b>	10-32 x 1-1/4	100
345	10-32 x 1-1/2	-
3455	10-32 x 1-3/4	-
346	10-32 x 2"	-
3461	10-32 x 2-1/4	-
3462	10-32 x 2-1/2	-
347	10-32 x 3"	-
348	10-24 x 1/4	-
<b>S349</b>	10-24 x 3/8	100
<b>S350</b>	10-24 x 1/2	100
351	10-24 x 5/8	-
<b>S352</b>	10-24 x 3/4	100
<b>S353</b>	10-24 x 7/8	100
<b>S354</b>	10-24 x 1"	100
<b>S355</b>	10-24 x 1-1/4	100
<b>S356</b>	10-24 x 1-1/2	100
3565	10-24 x 1-3/4	-
357	10-24 x 2"	-
3575	10-24 x 2-1/4	-
358	10-24 x 2-1/2	-
3585	10-24 x 3"	-

(CONTINUED)

### STAINLESS STEEL SLOTTED FLAT HEAD MACHINE SCREWS



STOCK NO.	SIZE	BOX QTY.
359	1/4-20 x 3/8	-
<b>S360</b>	1/4-20 x 1/2	100
361	1/4-20 x 5/8	-
<b>S362</b>	1/4-20 x 3/4	100
3625	1/4-20 x 7/8	-
<b>S363</b>	1/4-20 x 1"	100
<b>S364</b>	1/4-20 x 1-1/4	100
<b>S365</b>	1/4-20 x 1-1/2	100
<b>S366</b>	1/4-20 x 1-3/4	100
<b>S367</b>	1/4-20 x 2"	50
3671	1/4-20 x 2-1/4	-
<b>S3672</b>	1/4-20 x 2-1/2	50
<b>S3673</b>	1/4-20 x 3"	50
<b>S3675</b>	1/4-20 x 4"	25
368	5/16-18 x 1/2	100
<b>S369</b>	5/16-18 x 3/4	100
<b>S370</b>	5/16-18 x 1"	100
<b>S3705</b>	5/16-18 x 1-1/4	100
<b>S371</b>	5/16-18 x 1-1/2	100
3715	5/16-18 x 1-3/4	-
<b>S372</b>	5/16-18 x 2"	100
<b>S373</b>	5/16-18 x 2-1/2	50
<b>S374</b>	5/16-18 x 3"	25
375	3/8-16 x 1/2	-
3755	3/8-16 x 5/8	-
376	3/8-16 x 3/4	-
<b>S378</b>	3/8-16 x 1"	100
<b>S3785</b>	3/8-16 x 1-1/4	100
<b>S380</b>	3/8-16 x 1-1/2	100
381	3/8-16 x 1-3/4	-
<b>S382</b>	3/8-16 x 2"	50
3825	3/8-16 x 2-1/4	-
<b>S383</b>	3/8-16 x 2-1/2	50
3835	3/8-16 x 2-3/4	-
<b>S384</b>	3/8-16 x 3"	25
3845	3/8-16 x 3-1/2	-
385	3/8-16 x 4"	-
3855	3/8-16 x 4-1/2	-
386	3/8-16 x 5"	-
<b>S3864</b>	1/2-13 x 1-1/4	50
3865	1/2-13 x 1-1/2	-
3867	1/2-13 x 2"	-
<b>S3869</b>	1/2-13 x 2-1/2	25

**WE ARE YOUR  
ONE-STOP  
SOURCE FOR  
INDUSTRIAL  
SUPPLIES**

**STAINLESS STEEL MACHINE SCREWS**

**STAINLESS STEEL PHILLIPS FLAT HEAD MACHINE SCREWS**

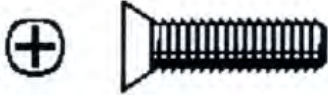

STOCK NO.	SIZE	BOX QTY.
S3875	2-56 x 1/8	100
S3876	2-56 x 1/4	100
S3877	2-56 x 5/16	100
S3878	2-56 x 3/8	100
S3886	4-40 x 1/4	100
S3888	4-40 x 3/8	100
S3890	4-40 x 1/2	100
S3891	4-40 x 3/4	100
S3892	4-40 x 1"	100
S3896	6-32 x 1/4	100
S3898	6-32 x 3/8	100
S3904	6-32 x 1/2	100
S3905	6-32 x 3/4	100
S3906	6-32 x 1"	100
S3907	6-32 x 1-1/4	100
S3908	6-32 x 1-1/2	100
S3910	6-32 x 2"	100
S3912	8-32 x 1/4	100
S3914	8-32 x 3/8	100
S3916	8-32 x 1/2	100
S3918	8-32 x 3/4	100
S3920	8-32 x 1"	100
S3921	8-32 x 1-1/4	100
S3922	8-32 x 1-1/2	100
S3923	8-32 x 1-3/4	100
S3924	8-32 x 2"	100
S3926	10-24 x 3/8	100
S3928	10-24 x 1/2	100
S3929	10-24 x 5/8	100
S3930	10-24 x 3/4	100
S3932	10-24 x 1"	100
S3933	10-24 x 1-1/4	100
S3934	10-24 x 1-1/2	100
S3936	10-24 x 2"	100
S3938	10-32 x 3/8	100
S3940	10-32 x 1/2	100
S3941	10-32 x 5/8	100
S3942	10-32 x 3/4	100
S3944	10-32 x 1"	100
S3945	10-32 x 1-1/4	100
S3946	10-32 x 1-1/2	100
S3948	10-32 x 2"	100
3950	1/4-20 x 3/8	-
S3952	1/4-20 x 1/2	100
S3954	1/4-20 x 3/4	100
S3956	1/4-20 x 1"	100
S3957	1/4-20 x 1-1/4	100
S3958	1/4-20 x 1-1/2	100
S3960	1/4-20 x 2"	50
S3962	1/4-20 x 2-1/2	50
S3964	1/4-20 x 3"	50
S3967	5/16 x 3/4	-
S3968	5/16 x 1"	-
S3969	5/16 x 1-1/4	-
S3970	5/16 x 1-1/2	-
S3971	5/16 x 2"	-

**ADDITIONAL SIZES AND ITEMS AVAILABLE UPON REQUEST**

**STAINLESS STEEL PHILLIPS PAN HEAD MACHINE SCREWS**

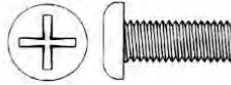

STOCK NO.	SIZE	BOX QTY.
4012	4-40 x 3/16	-
S4014	4-40 x 1/4	100
4015	4-40 x 3/8	-
S4016	4-40 x 1/2	100
4017	4-40 x 5/8	-
4018	4-40 x 3/4	-
4020	4-40 x 1"	-
4021	4-40 x 1-1/4	-
4024	6-32 x 3/16	-
S4025	6-32 x 1/4	100
S4027	6-32 x 3/8	100
S4028	6-32 x 1/2	100
S4029	6-32 x 5/8	100
S4030	6-32 x 3/4	100
S4032	6-32 x 1"	100
S4038	8-32 x 1/4	100
S4039	8-32 x 3/8	100
S4040	8-32 x 1/2	100
S4041	8-32 x 5/8	100
S4042	8-32 x 3/4	100
S4044	8-32 x 1"	100
S4045	8-32 x 1-1/4	100
S4046	8-32 x 1-1/2	100
S4048	8-32 x 2"	100
S4055	10-24 x 1/4	100
S4057	10-24 x 3/8	100
S4058	10-24 x 1/2	100
S4059	10-24 x 5/8	100
S4060	10-24 x 3/4	100
S4062	10-24 x 1"	100
S4063	10-24 x 1-1/4	100
S4064	10-24 x 1-1/2	100
S4065	10-24 x 2"	100
S4067	10-24 x 2-1/2	100
S4068	10-24 x 3"	100
S4069	10-24 x 3-1/2	100
4071	10-32 x 1/4	-
S4073	10-32 x 3/8	100
S4074	10-32 x 1/2	100
S4075	10-32 x 5/8	100
S4076	10-32 x 3/4	100
S4078	10-32 x 1"	100
S4079	10-32 x 1-1/4	100
S4080	10-32 x 1-1/2	100
S4082	10-32 x 2"	100
S4083	10-32 x 2-1/4	100
4087	1/4-20 x 3/8	-
S4088	1/4-20 x 1/2	100
S4090	1/4-20 x 3/4	100
S4092	1/4-20 x 1"	100
S4093	1/4-20 x 1-1/4	100
S4094	1/4-20 x 1-1/2	100
S4096	1/4-20 x 2"	100

**STAINLESS STEEL PHILLIPS TRUSS HEAD MACHINE SCREWS**

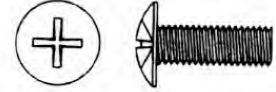

STOCK NO.	SIZE	BOX QTY.
S40999	4-40 x 3/16	100
S4100	4-40 x 1/4	100
S4110	6-32 x 1/4	100
S41105	6-32 x 5/16	100
S4111	6-32 x 3/8	100
S4112	6-32 x 1/2	100
S4113	6-32 x 5/8	100
S4114	6-32 x 3/4	100
S4115	6-32 x 1"	100
S4125	8-32 x 1/4	100
S4126	8-32 x 3/8	100
S4127	8-32 x 1/2	100
S41275	8-32 x 5/8	100
S4128	8-32 x 3/4	100
S4129	8-32 x 1"	100
S4130	8-32 x 1-1/4	100
S4131	8-32 x 1-1/2	100
S4135	10-24 x 1/4	100
S4136	10-24 x 3/8	100
S4137	10-24 x 1/2	100
S41381	10-24 x 5/8	100
S4139	10-24 x 3/4	100
S4140	10-24 x 1"	100
S4141	10-24 x 1-1/4	100
S4142	10-24 x 1-1/2	100
S4143	10-24 x 1-3/4	100
S4144	10-24 x 2"	100
S4150	10-32 x 1/4	100
S4151	10-32 x 3/8	100
S4152	10-32 x 1/2	100
S4153	10-32 x 5/8	100
S4154	10-32 x 3/4	100
S4155	10-32 x 1"	100
S4156	10-32 x 1-1/4	100
S4157	10-32 x 1-1/2	100
S4158	10-32 x 1-3/4	100
S4159	10-32 x 2"	100
S4165	1/4-20 x 3/8	100
S4166	1/4-20 x 1/2	100
S4167	1/4-20 x 5/8	100
S4168	1/4-20 x 3/4	100
S4169	1/4-20 x 1"	100
S4170	1/4-20 x 1-1/4	100
S4171	1/4-20 x 1-1/2	100
S4173	1/4-20 x 2"	100
S4174	1/4-20 x 2-1/4	100
S4175	1/4-20 x 2-1/2	100
S41751	1/4-20 x 3"	100

THE DINER WAS FURIOUS WHEN HIS STEAK ARRIVED TOO RARE. "WAITER," HE BARKED, "DIDN'T YOU HEAR ME SAY 'WELL DONE?'" "I CAN'T THANK YOU ENOUGH SIR," REPLIED THE WAITER. "I HARDLY EVER GET A COMPLIMENT."



### STAINLESS STEEL MACHINE SCREWS

#### STAINLESS STEEL PHILLIPS ROUND HEAD MACHINE SCREWS



STOCK NO.	SIZE	BOX QTY.
S4211	4-40 x 1/2	100
S4215	4-40 x 1"	100
4223	6-32 x 1/4	-
4224	6-32 x 3/8	-
S4225	6-32 x 1/2	100
4227	6-32 x 3/4	-
4229	6-32 x 1"	-
4231	6-32 x 1-1/2	-
4233	6-32 x 2"	-
S4235	8-32 x 3/8	100
S4236	8-32 x 1/2	100
S4238	8-32 x 3/4	100
S4240	8-32 x 1"	100
4242	8-32 x 1-1/2	-
4244	8-32 x 2"	-
S4246	10-32 x 1/2	100
S4248	10-32 x 3/4	100
4249	10-32 x 7/8	-
S4250	10-32 x 1"	100
S4252	10-32 x 1-1/2	100
4254	10-32 x 2"	-
S4256	10-24 x 1/2	100
4258	10-24 x 3/4	-
4260	10-24 x 1"	-
4262	10-24 x 1-1/2	-
4264	10-24 x 2"	-
4267	1/4-20 x 1/2	-
4269	1/4-20 x 3/4	-
4271	1/4-20 x 1"	-
4273	1/4-20 x 1-1/2	-
4275	1/4-20 x 2"	-

**ADDITIONAL SIZES AND ITEMS AVAILABLE UPON REQUEST**

A SKY DIVER AND HIS INSTRUCTOR PEERED DOWN AT THE FIELD 3,000 FEET BELOW. "THERE'S NOTHING TO WORRY ABOUT," THE INSTRUCTOR SAID. "YOU JUMP, COUNT TO THREE AND PULL YOUR RIP CORD. IF THAT DOESN'T WORK, PULL YOUR RESERVE CORD. THERE'LL BE A TRUCK DOWN THERE TO PICK YOU UP."

THE SKY DIVER TOOK A DEEP BREATH AND PLUNGED INTO THE OPEN AIR. AFTER FREE-FALLING, HE COUNTED TO THREE, THEN PULLED HIS RIP CORD. NOTHING HAPPENED. SO HE PULLED THE RESERVE. A FEW COBWEBS DRIFTED OUT.

"DARN," HE SAID. "I'LL BET THAT TRUCK'S NOT DOWN THERE EITHER."

#### STAINLESS STEEL SLOTTED PAN HEAD MACHINE SCREWS

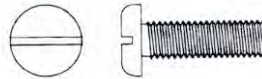

STOCK NO.	SIZE	BOX QTY.
S45010	2-56 x 1"	100
45015	4-40 x 1/8	-
S45016	4-40 x 3/16	100
S45017	4-40 x 1/4	100
S45018	4-40 x 3/8	100
S45021	4-40 x 1/2	100
45023	4-40 x 3/4	-
45025	4-40 x 1"	-
45029	6-32 x 3/16	-
S45030	6-32 x 1/4	100
S45032	6-32 x 3/8	100
45033	6-32 x 7/16	-
S45034	6-32 x 1/2	100
S45035	6-32 x 5/8	100
45036	6-32 x 3/4	-
45038	6-32 x 1"	-
45040	6-32 x 1-1/2	-
S45044	8-32 x 1/4	100
S45046	8-32 x 3/8	100
S45048	8-32 x 1/2	100
S45049	8-32 x 5/8	100
S45050	8-32 x 3/4	100
S45052	8-32 x 1"	100
45054	8-32 x 1-1/2	-
45058	10-24 x 1/4	-
S45060	10-24 x 3/8	100
S45062	10-24 x 1/2	100
45063	10-24 x 5/8	-
S45064	10-24 x 3/4	100
S45066	10-24 x 1"	100
S45067	10-24 x 1-1/4	100
S45068	10-24 x 1-1/2	100
S45070	10-24 x 2"	100
45072	10-32 x 1/4	-
45074	10-32 x 3/8	-
S45076	10-32 x 1/2	100
45077	10-32 x 5/8	-
S45078	10-32 x 3/4	100
45080	10-32 x 1"	-
45081	10-32 x 1-1/4	-
45082	10-32 x 1-1/2	-
45084	10-32 x 2"	-
45087	1/4-20 x 3/8	-
S45089	1/4-20 x 1/2	100
45091	1/4-20 x 3/4	-
S45093	1/4-20 x 1"	100
45094	1/4-20 x 1-1/4	-
45095	1/4-20 x 1-1/2	-
45096	1/4-20 x 1-3/4	-
45097	1/4-20 x 2"	-
45101	5/16-18 x 1/2	-
45103	5/16-18 x 3/4	-
45105	5/16-18 x 1"	-
45106	5/16-18 x 1-1/4	-
45107	5/16-18 x 1-1/2	-
45109	5/16-18 x 2"	-

(CONTINUED)

#### STAINLESS STEEL SLOTTED PAN HEAD MACHINE SCREWS

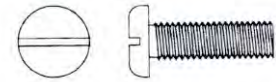

STOCK NO.	SIZE	BOX QTY.
45110	3/8-16 x 1/2	-
45112	3/8-16 x 3/4	-
45114	3/8-16 x 1"	-
45115	3/8-16 x 1-1/4	-
45116	3/8-16 x 1-1/2	-
45117	3/8-16 x 1-3/4	-
45118	3/8-16 x 2"	-

#### STAINLESS STEEL HEX HEAD MACHINE SCREWS

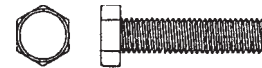

STOCK NO.	SIZE	BOX QTY.
S2391	10-24 x 3/8	100
S2392	10-24 x 1/2	100
S2393	10-24 x 5/8	100
S2394	10-24 x 3/4	100
S2395	10-24 x 1"	100

**THIS SPACE RESERVED FOR FUTURE STAINLESS STEEL FASTENER ITEMS**

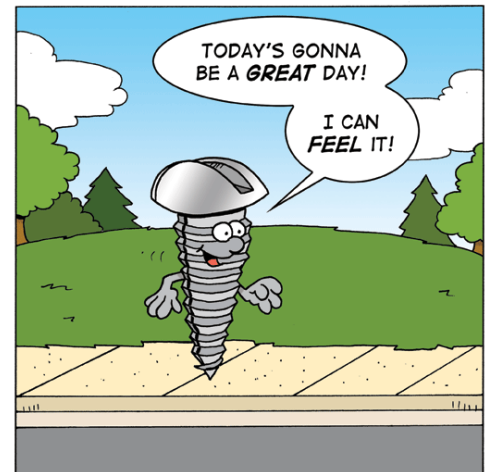

SPUDCOMICS.COM © 2010 LONNIE EASTERLING

**BEFORE HE GOT SCREWED**

**BRASS HEX HEAD CAP SCREWS AND MACHINE SCREWS**

**BRASS HEX HEAD CAP SCREWS**



STOCK NO.	SIZE	BOX QTY.
BF001	1/4-20 x 1/2	100
BF002	1/4-20 x 3/4	100
BF003	1/4-20 x 1"	100
BF004	1/4-20 x 1-1/4	100
BF005	1/4-20 x 1-1/2	100
BF006	1/4-20 x 1-3/4	100
BF007	1/4-20 x 2"	100
008	1/4-20 x 2-1/4	-
BF009	1/4-20 x 2-1/2	100
010	1/4-20 x 2-3/4	-
011	1/4-20 x 3"	-
012	5/16-18 x 1/2	-
0125	5/16-18 x 5/8	-
BF013	5/16-18 x 3/4	100
BF014	5/16-18 x 1"	100
BF015	5/16-18 x 1-1/4	100
BF016	5/16-18 x 1-1/2	100
017	5/16-18 x 1-3/4	-
BF018	5/16-18 x 2"	100
0185	5/16-18 x 2-1/4	-
BF019	5/16-18 x 2-1/2	50
0195	5/16-18 x 2-3/4	-
BF020	5/16-18 x 3"	50
BF023	3/8-16 x 3/4	100
BF024	3/8-16 x 1"	100
BF025	3/8-16 x 1-1/4	100
BF026	3/8-16 x 1-1/2	100
BF027	3/8-16 x 1-3/4	50
BF028	3/8-16 x 2"	50
BF029	3/8-16 x 2-1/4	50
BF030	3/8-16 x 2-1/2	50
BF031	3/8-16 x 2-3/4	50
BF032	3/8-16 x 3"	50
BF033	3/8-16 x 3-1/2	50
BF034	3/8-16 x 4"	25
BF035	3/8-16 x 4-1/2	25
BF0359	1/2-13 x 3/4	50
BF036	1/2-13 x 1"	50
BF037	1/2-13 x 1-1/4	50
BF038	1/2-13 x 1-1/2	50
BF039	1/2-13 x 1-3/4	50
BF040	1/2-13 x 2"	25
BF041	1/2-13 x 2-1/4	25
BF042	1/2-13 x 2-1/2	25
BF044	1/2-13 x 3"	25
045	1/2-13 x 3-1/2	-
046	1/2-13 x 4"	-
047	1/2-13 x 4-1/2	-
BF0481	5/8-11 x 1-1/4	25
BF049	5/8-11 x 1-1/2	25
BF051	5/8-11 x 2"	25
BF053	5/8-11 x 2-1/2	25
BF055	5/8-11 x 3"	25
BF056	5/8-11 x 3-1/2	25

**LIMITED INVENTORY OF  
SILICONE BRONZE FASTENERS  
IN STOCK.**

**CALL FOR AVAILABILITY.**

**BRASS SLOTTED FLAT HEAD  
MACHINE SCREWS**



STOCK NO.	SIZE	BOX QTY.
BF098	4-40 x 1/2	100
099	4-40 x 3/4	-
100	4-40 x 1"	-
BF105	6-32 x 1/4	100
BF106	6-32 x 3/8	100
BF107	6-32 x 1/2	100
BF109	6-32 x 3/4	100
BF110	6-32 x 1"	100
BF112	6-32 x 1-1/2	100
113	6-32 x 1-3/4	-
BF114	6-32 x 2"	100
BF117	8-32 x 1/4	100
BF119	8-32 x 3/8	100
BF120	8-32 x 1/2	100
BF122	8-32 x 3/4	100
BF123	8-32 x 1"	100
124	8-32 x 1-1/4	-
BF125	8-32 x 1-1/2	100
126	8-32 x 1-3/4	-
BF127	8-32 x 2"	100
BF128	8-32 x 2-1/2	100
BF132	10-24 x 1/4	100
BF133	10-24 x 3/8	100
BF135	10-24 x 1/2	100
BF137	10-24 x 3/4	100
BF138	10-24 x 1"	100
BF139	10-24 x 1-1/4	100
BF140	10-24 x 1-1/2	100
141	10-24 x 1-3/4	-
BF142	10-24 x 2"	100
BF144	10-24 x 3"	100
BF150	10-32 x 1/2	100
BF152	10-32 x 3/4	100
BF153	10-32 x 1"	100
BF154	10-32 x 1-1/4	100
BF155	10-32 x 1-1/2	100
-	10-32 x 1-3/4	-
BF156	10-32 x 2"	100
BF161	1/4-20 x 3/8	100
BF162	1/4-20 x 1/2	100
BF163	1/4-20 x 5/8	100
BF164	1/4-20 x 3/4	100
BF165	1/4-20 x 1"	100
BF166	1/4-20 x 1-1/4	100
BF167	1/4-20 x 1-1/2	100
BF168	1/4-20 x 1-3/4	100
BF169	1/4-20 x 2"	100
BF170	1/4-20 x 2-1/4	100
BF171	1/4-20 x 2-1/2	100
BF173	1/4-20 x 3"	50
BF174	1/4-20 x 3-1/2	50
BF175	1/4-20 x 4"	50
1759	5/16-18 x 5/8	-
BF176	5/16-18 x 3/4	100
BF177	5/16-18 x 1"	100
BF178	5/16-18 x 1-1/4	100
BF179	5/16-18 x 1-1/2	100

(CONTINUED NEXT COLUMN)

**BRASS SLOTTED FLAT HEAD  
MACHINE SCREWS**



STOCK NO.	SIZE	BOX QTY.
BF180	5/16-18 x 1-3/4	100
BF181	5/16-18 x 2"	100
BF183	5/16-18 x 2-1/2	50
BF185	5/16-18 x 3"	50
BF187	5/16-18 x 4"	50
1874	5/16-18 x 5"	-
BF189	3/8-16 x 3/4	100
BF190	3/8-16 x 1"	100
BF191	3/8-16 x 1-1/4	100
BF192	3/8-16 x 1-1/2	100
BF193	3/8-16 x 1-3/4	50
BF194	3/8-16 x 2"	50
BF195	3/8-16 x 2-1/4	50
BF196	3/8-16 x 2-1/2	50
BF197	3/8-16 x 2-3/4	50
BF198	3/8-16 x 3"	50
BF199	3/8-16 x 3-1/2	25
BF200	3/8-16 x 4"	25
201	3/8-16 x 5"	-
BF203	1/2-13 x 3/4	50
BF204	1/2-13 x 1"	50
BF205	1/2-13 x 1-1/4	50
BF206	1/2-13 x 1-1/2	50
BF207	1/2-13 x 1-3/4	50
BF208	1/2-13 x 2"	50
BF210	1/2-13 x 2-1/2	25
BF212	1/2-13 x 3"	25
BF214	1/2-13 x 3-1/2	25
-	1/2-13 x 4"	-
BF216	5/8-11 x 1-1/4	25
BF217	5/8-11 x 1-1/2	25
BF218	5/8-11 x 1-3/4	25
2181	5/8-11 x 2"	-
BF219	5/8-11 x 3"	25

**BRASS SLOTTED ROUND HEAD  
MACHINE SCREWS**



STOCK NO.	SIZE	BOX QTY.
BF252	4-40 x 1/2	100
2522	4-40 x 3/4	-
2524	4-40 x 1"	-
BF2526	4-40 x 1-1/4	100
BF255	6-32 x 1/4	100
BF257	6-32 x 3/8	100
BF258	6-32 x 1/2	100
BF259	6-32 x 3/4	100
BF2591	6-32 x 7/8	100
BF2592	6-32 x 1"	100
BF260	6-32 x 1-1/4	100
BF261	6-32 x 1-1/2	100
BF262	6-32 x 2"	100
2621	6-32 x 2-1/2	-

(CONTINUED NEXT PAGE)

## BRASS MACHINE SCREWS, LOCK WASHERS, FLAT WASHERS AND HEX NUTS

### BRASS SLOTTED ROUND HEAD MACHINE SCREWS



STOCK NO.	SIZE	BOX QTY.
BF2629	8-32 x 1/4	100
BF263	8-32 x 3/8	100
BF264	8-32 x 1/2	100
BF265	8-32 x 3/4	100
BF266	8-32 x 1"	100
BF267	8-32 x 1-1/4	100
BF268	8-32 x 1-1/2	100
269	8-32 x 1-3/4	-
BF270	8-32 x 2"	100
BF272	8-32 x 3"	100
BF273	10-32 x 1/4	100
BF274	10-32 x 3/8	100
BF275	10-32 x 1/2	100
BF276	10-32 x 3/4	100
BF2766	10-32 x 7/8	100
BF277	10-32 x 1"	100
BF278	10-32 x 1-1/4	100
BF279	10-32 x 1-1/2	100
280	10-32 x 1-3/4	-
BF281	10-32 x 2"	100
283	10-32 x 3"	-
BF286	10-24 x 3/8	100
BF287	10-24 x 1/2	100
BF288	10-24 x 3/4	100
BF289	10-24 x 1"	100
BF290	10-24 x 1-1/4	100
BF291	10-24 x 1-1/2	100
292	10-24 x 1-3/4	-
BF293	10-24 x 2"	100
BF299	12-24 x 1"	100
BF305	1/4-20 x 3/8	100
BF306	1/4-20 x 1/2	100
BF307	1/4-20 x 3/4	100
3075	1/4-20 x 7/8	-
BF308	1/4-20 x 1"	100
BF309	1/4-20 x 1-1/4	100
BF310	1/4-20 x 1-1/2	100
311	1/4-20 x 1-3/4	-
BF312	1/4-20 x 2"	100
BF314	1/4-20 x 2-1/2	50
BF316	1/4-20 x 3"	50
319	5/16-18 x 1/2	-
BF320	5/16-18 x 3/4	100
BF321	5/16-18 x 1"	100
BF323	5/16-18 x 1-1/2	100
BF324	5/16-18 x 2"	100
326	5/16-18 x 2-1/2	-
BF330	3/8-16 x 1/2	100
BF331	3/8-16 x 3/4	50
BF332	3/8-16 x 1"	50
BF3325	3/8-16 x 1-1/4	50
BF334	3/8-16 x 1-1/2	50
BF336	3/8-16 x 2"	50
BF338	3/8-16 x 2-1/2	50
BF340	1/2-13 x 1"	50

ADDITIONAL SIZES AVAILABLE UPON REQUEST

### SILICON BRONZE LOCK WASHERS



STOCK NO.	SIZE	BOX QTY.
BF350	#4	100
BF351	#6	100
BF352	#8	100
BF353	#10	100
3535	#12	-
BF354	1/4	100
BF355	5/16	100
BF356	3/8	100
BF358	1/2	100
BF359	5/8	100
BF360	3/4	100
362	1"	-

### BRASS FLAT WASHERS



STOCK NO.	SIZE	BOX QTY.
BF600	#4	100
BF601	#6	100
BF6015	#8-SM	100
BF602	#8-LG	100
BF604	#10-SM	100
BF605	#10-LG	100
BF6052	#12-LG	100
BF606	1/4-SM	100
BF607	1/4-LG	100
BF608	18-SM	100
BF609	18-LG	100
BF610	5/16-SM	100
BF611	5/16-LG	100
BF612	3/8-SM	100
BF613	3/8-LG	100
BF6135	7/16	100
BF614	1/2-SM	100
BF615	1/2-LG	100
BF616	5/8-SM	50
BF618	3/4-SM	50
BF620	7/8	50
621	1"	-
BF622	1-1/4	25

### BRASS FINISHING WASHERS



STOCK NO.	SIZE	BOX QTY.
BF663	#8	100
BF664	#10	100
667	#14	-

ADDITIONAL SIZES AVAILABLE UPON REQUEST

### COPPER WASHERS - AUTOMOTIVE

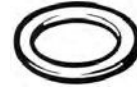

STOCK NO.	BOLT SIZE	OUTSIDE DIA.	INSIDE DIA.	BOX QTY.
AV15914	3/16	5/8	1/4	25
AV15915	1/4	11/16	5/16	25
AV15916	5/16	3/4	3/8	25
AV15917	3/8	13/16	7/16	25
AV15918	7/16	7/8	1/2	25

### COPPER WASHERS - INDUSTRIAL



STOCK NO.	BOLT SIZE	OUTSIDE DIA.	INSIDE DIA.	BOX QTY.
CFW004	1/4	5/8	9/32	100
CFW005	5/16	3/4	11/32	100
CFW006	3/8	7/8	13/32	100
CFW008	1/2	1-1/4	17/32	100
CFW009	5/8	1-1/2	11/16	25
CFW010	3/4	1-7/8	13/16	25



### BRASS USS COARSE THREAD HEX NUTS

STOCK NO.	SIZE	BOX QTY.
BF377	4-40	100
BF378	6-32	100
BF379	8-32	100
BF380	10-32	100
BF381	10-24	100
BF382	12-24	100
BF383	1/4-20	100
BF384	5/16-18	100
BF385	3/8-16	100
BF386	7/16-14	100
BF387	1/2-13	50
BF388	5/8-11	25
BF389	3/4-10	25
BF390	7/8-9	25
BF391	1"-8	25
392	1-1/4-7	-

### BRASS SAE FINE THREAD HEX NUTS



STOCK NO.	SIZE	BOX QTY.
BF394	1/4-28	100
BF395	5/16-24	100
BF396	3/8-24	100
BF397	7/16-20	100
BF398	1/2-20	50

### BRASS HEX JAM NUTS



STOCK NO.	SIZE	BOX QTY.
BF428	1/4-20	100
BF429	5/16-18	100
BF430	3/8-16	100
BF432	1/2-13	100
433	5/8-11	-
434	3/4-10	-

**BRASS HEX NUTS, MISCELLANEOUS NUTS AND WOOD SCREWS**

**BRASS NYLON INSERT LOCK NUTS**



STOCK NO.	SIZE	BOX QTY.
BF406	8-32	100
BF407	10-24	100
BF408	10-32	100
BF410	1/4-20	100
BF411	5/16-18	100
BF412P	3/8-16	100
BF414	1/2-13	100
BF415P	5/8-11	50
BF416P	3/4-10	25

**BRASS WING NUTS**



STOCK NO.	SIZE	BOX QTY.
BF450	1/4-20	100
BF451	5/16-18	100
BF452	3/8-16	100
BF454	1/2-13	50

**BRASS HEX CAP NUTS**



STOCK NO.	SIZE	BOX QTY.
BF460	6-32	100
461	8-32	-
462	10-24	-
463	10-32	-
464	1/4-20	-
465	5/16-18	-
466	3/8-16	-
BF468	1/2-13	100

**ADDITIONAL SIZES AVAILABLE  
UPON REQUEST**

AN INEXPERINCED REAL-ESTATE SALESMAN ASKED HIS BOSS IF HE COULD REFUND THE DEPOSIT TO AN ANGRY CUSTOMER WHO HAD DISCOVERED THAT THE LOT HE HAD BOUGHT WAS UNDER WATER.

"WHAT KIND OF SALESMAN ARE YOU?" THE BOSS SCOLDED. "GET OUT THERE AND SELL HIM A BOAT."

**BRASS SLOTTED FLAT HEAD WOOD SCREWS**



STOCK NO.	SIZE	BOX QTY.
BF475	4 x 3/8	100
BF476	4 x 1/2	100
BF479	6 x 3/8	100
BF480	6 x 1/2	100
BF481	6 x 3/4	100
BF482	6 x 1"	100
BF483	6 x 1-1/4	100
BF484	6 x 1-1/2	100
BF486	8 x 1/2	100
BF487	8 x 3/4	100
BF488	8 x 1"	100
BF489	8 x 1-1/4	100
BF490	8 x 1-1/2	100
BF491	8 x 1-3/4	100
BF492	8 x 2"	100
BF497	10 x 1"	100
BF498	10 x 1-1/4	100
BF499	10 x 1-1/2	100
500	10 x 1-3/4	-
BF501	10 x 2"	100
BF502	10 x 2-1/2	100
BF503	10 x 3"	100
BF507	12 x 1"	100
BF509	12 x 1-1/2	100
BF511	12 x 2"	100
BF512	12 x 2-1/2	100
BF513	12 x 3"	100

**BRASS SLOTTED ROUND HEAD WOOD SCREWS**



STOCK NO.	SIZE	BOX QTY.
BF530	2 x 3/8	100
BF537	6 x 3/4	100
BF539	6 x 1-1/4	100
BF567	10 x 1"	100
BF568	10 x 1-1/4	100
BF573	12 x 2-1/2	100

**ADDITIONAL SIZES AVAILABLE  
UPON REQUEST**

**BRASS PHILLIPS FLAT HEAD WOOD SCREWS**



STOCK NO.	SIZE	BOX QTY.
6686	6 x 1/2	-
6687	6 x 3/4	-
6688	6 x 1"	-
6689	6 x 1-1/4	-
6690	6 x 1-1/2	-
6696	8 x 3/8	-
6698	8 x 3/4	-
BF6699	8 x 1"	100
BF6700	8 x 1-1/4	100
BF6701	8 x 1-1/2	100
6702	8 x 1-3/4	-
BF6703	8 x 2"	100
6705	8 x 2-1/2	100
6710	10 x 3/4	-
6711	10 x 1"	-
6712	10 x 1-1/4	-
6713	10 x 1-1/2	-
6715	10 x 2"	-
6717	10 x 2-1/2	-
6719	10 x 3"	-

**THIS SPACE RESERVED FOR FUTURE  
BRASS FASTENER PRODUCTS**



## NYLON FASTENERS

### NYLON HEX NUTS



STOCK NO.	SIZE	BOX QTY.
PMC005	6-32	100
PMC006	8-32	100
PMC007	10-24	100
PMC008	10-32	100
PMC01	1/4-20	100
PMC02	5/16-18	100
PMC03	3/8-16	100
PMC04	1/2-13	50
PMC041	5/8-11	50
PMC043	3/4-10	50

### NYLON FLAT WASHERS

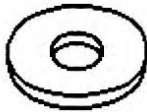

STOCK NO.	SIZE	OUTSIDE DIA.	INSIDE DIA.	BOX QTY.
PMC065	#6	.375	.150	100
PMC066	#8	.408	.177	100
PMC067	#10	.450	.200	100
PMC069	1/4	.750	.261	100
PMC070	5/16	.880	.343	100
PMC071	3/8	1.00	.406	100
PMC072	3/8	.625	.380	100
PMC075	5/8	1.50	.630	50
PMC076	3/4	1.5	.755	50

### NYLON ALLTHREAD



3 FT. LENGTHS

NATURAL COLOR - CORROSION RESISTANT

STOCK NO.	SIZE
PMC75	1/4-20
PMC76	5/16-18
PMC77	3/8-16
PMC78	1/2-13

ADDITIONAL NYLON FASTENERS AND SIZES  
AVAILABLE UPON REQUEST

### NYLON HEX HEAD CAP SCREWS



STOCK NO.	SIZE	BOX QTY.
PMC11	1/4-20 x 3/4	50
PMC12	1/4-20 x 1"	50
PMC121	1/4-20 x 1-1/4	50
PMC122	1/4-20 x 1-1/2	50
PMC124	1/4-20 x 2"	50
PMC15	5/16-18 x 3/4	50
PMC16	5/16-18 x 1"	50
PMC161	5/16-18 x 1-1/4	50
PMC162	5/16-18 x 1-1/2	50
PMC164	5/16-18 x 2"	50
PMC20	3/8-16 x 1"	50
PMC201	3/8-16 x 1-1/4	50
PMC202	3/8-16 x 1-1/2	50
PMC204	3/8-16 x 2"	50
PMC206	3/8-16 x 2-1/2	50
PMC248	1/2-13 x 1-1/2	25
PMC25	1/2-13 x 2"	25



ADDITIONAL NYLON FASTENERS AND SIZES  
AVAILABLE UPON REQUEST

WE HAVE A  
LIMITED INVENTORY  
ON NYLON FASTENERS,  
BUT ARE CONTINUALLY  
ADDING ITEMS  
TO OUR STOCK.  
LET US KNOW YOUR NEEDS.

### NYLON SLOTTED ROUND HEAD MACHINE SCREWS

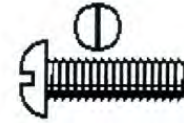

STOCK NO.	SIZE	BOX QTY.
PMC265	4-40 x 5/8	100
PMC268	6-32 x 1/4	100
PMC269	6-32 x 3/8	100
PMC270	6-32 x 1/2	100
PMC271	6-32 x 5/8	100
PMC272	6-32 x 3/4	100
PMC274	6-32 x 1"	100
PMC280	8-32 x 1/2	100
PMC286	8-32 x 1-1/2	100
PMC309	1/4-20 x 3/4	100
PMC312	1/4-20 x 1-1/2	100

### NYLON SLOTTED PAN HEAD MACHINE SCREWS

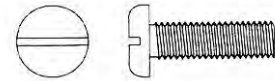

STOCK NO.	SIZE	BOX QTY.
PMC3162	6-32 x 1/2	100
PMC3164	6-32 x 3/4	100
PMC3166	6-32 x 1"	100
PMC3173	8-32 x 1/2	100
PMC3175	8-32 x 3/4	100
PMC3176	8-32 x 1"	100
PMC3182	10-32 x 1/2	100
PMC3183	10-32 x 3/4	100
PMC3184	10-32 x 1"	100
PMC3189	10-24 x 1/2	100
PMC3190	10-24 x 3/4	100
PMC3191	10-24 x 1"	100
PMC3199	1/4-20 x 1/2	100
PMC3201	1/4-20 x 3/4	100
PMC3202	1/4-20 x 1"	100

### NYLON SLOTTED FLAT HEAD MACHINE SCREWS

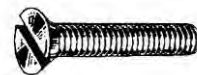

STOCK NO.	SIZE	BOX QTY.
PMC370	4-40 x 1/2	100
PMC3750	6-32 x 1/2	100
PMC3751	6-32 x 5/8	100
PMC3752	6-32 x 3/4	100
PMC3754	6-32 x 1"	100
PMC3775	8-32 x 1/2	100
PMC3777	8-32 x 3/4	100
PMC3779	8-32 x 1"	100
PMC3790	10-32 x 1/2	100
PMC3792	10-32 x 3/4	100
PMC3794	10-32 x 1"	100
PMC3833	1/4-20 x 3/4	100
PMC3835	1/4-20 x 1"	100
PMC3837	1/4-20 x 1-1/2	100



METRIC HEX HEAD CAP SCREWS - COARSE THREAD

HEX HEAD CAP SCREWS

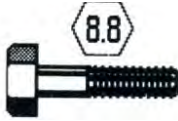

M3 x 0.5 PITCH

STOCK NO.	SIZE	BOX QTY.
M00135	M3 x 8mm	100
M00138	M3 x 14	100
<b>M4 x 0.7 PITCH</b>		
M002	M4 x 8mm	100
M003	M4 x 10	100
M004	M4 x 12	100
M0045	M4 x 14	100
M005	M4 x 16	100
M0052	M4 x 18	100
M0055	M4 x 20	100
M0057	M4 x 22	100
M006	M4 x 25	100
M007	M4 x 30	100
M008	M4 x 35	100
M009	M4 x 40	100
<b>M5 x 0.8 PITCH</b>		
M010	M5 x 8mm	100
M0102	M5 x 10	100
M0103	M5 x 12	100
M0104	M5 x 14	100
M0105	M5 x 16	100
M0107	M5 x 18	100
M011	M5 x 20	100
M0115	M5 x 22	100
M012	M5 x 25	100
M013	M5 x 30	100
M0131	M5 x 35	100
M014	M5 x 40	100
0141	M5 x 45	-
M015	M5 x 50	100
M016	M5 x 55	100
M017	M5 x 60	100
0172	M5 x 65	-
0173	M5 x 70	-
M0174	M5 x 80	100
<b>M6 x 1.00 PITCH</b>		
M019	M6 x 8mm	100
M020	M6 x 10	100
M021	M6 x 12	100
M0215	M6 x 14	100
M022	M6 x 16	100
M023	M6 x 18	100
M024	M6 x 20	100
M025	M6 x 25	100
M026	M6 x 30	100
M027	M6 x 35	100
M028	M6 x 40	100
M029	M6 x 45	100
M030	M6 x 50	100
M031	M6 x 55	100
M032	M6 x 60	100
M033	M6 x 65	100
M0335	M6 x 70	100
M034	M6 x 75	100
M035	M6 x 80	100
M0361	M6 x 90	-
-	M6 x 100	-
-	M6 x 110	-
-	M6 x 120	-
M0395	M6 x 130	-

HEX HEAD CAP SCREWS



M7 x 1.00 PITCH

STOCK NO.	SIZE	BOX QTY.
M040	M7 x 12mm	100
M041	M7 x 20	100
M0412	M7 x 25	100
M0414	M7 x 30	100
M04145	M7 x 35	100
M042	M7 x 40	100
M043	M7 x 45	100
M044	M7 x 50	100
<b>M8 x 1.25 PITCH</b>		
-	M8 x 10mm	-
M050	M8 x 12	100
M051	M8 x 16	100
M0515	M8 x 18	100
M052	M8 x 20	100
M053	M8 x 25	100
M054	M8 x 30	100
M055	M8 x 35	100
M056	M8 x 40	100
M057	M8 x 45	100
M058	M8 x 50	100
M0581	M8 x 55	100
M0582	M8 x 60	100
M0583	M8 x 65	100
M0584	M8 x 70	100
M0585	M8 x 75	100
M0586	M8 x 80	100
M0588	M8 x 90	100
M0589	M8 x 100	100
05895	M8 x 110	-
M059	M8 x 120	100
<b>M10 x 1.50 PITCH</b>		
M070	M10 x 16mm	100
M071	M10 x 20	100
M072	M10 x 25	100
M073	M10 x 30	100
M074	M10 x 35	100
M075	M10 x 40	100
M076	M10 x 45	100
M077	M10 x 50	50
M0773	M10 x 55	50
M0775	M10 x 60	50
M078	M10 x 65	50
M079	M10 x 70	50
M0791	M10 x 75	50
M0792	M10 x 80	25
M0793	M10 x 85	25
M0795	M10 x 90	25
M080	M10 x 100	25
M0801	M10 x 110	25
M0803	M10 x 120	25
M0804	M10 x 130	25
M0805	M10 x 140	25
M081	M10 x 150	25
082	M10 x 160	-
083	M10 x 170	-
M087	M10 x 180	25

HEX HEAD CAP SCREWS

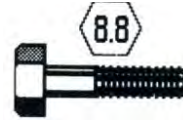

M12 x 1.75 PITCH

STOCK NO.	SIZE	BOX QTY.
M093	M12 x 20mm	50
M095	M12 x 25	50
M096	M12 x 30	50
M097	M12 x 35	50
M098	M12 x 40	50
M099	M12 x 45	50
M100	M12 x 50	50
M101	M12 x 55	50
M1011	M12 x 60	50
M102	M12 x 65	50
M103	M12 x 70	50
M1035	M12 x 75	25
M104	M12 x 80	25
M1042	M12 x 85	25
M1046	M12 x 90	25
M105	M12 x 100	25
M1052	M12 x 110	25
M1054	M12 x 120	25
M1056	M12 x 130	25
M1058	M12 x 140	25
M1059	M12 x 150	25
M106	M12 x 160	25
107	M12 x 170	-
108	M12 x 180	-
M109	M12 x 190	25
M1095	M12 x 200	25
M110	M12 x 210	25
111	M12 x 220	-
<b>M14 x 2.00 PITCH</b>		
M116	M14 x 25mm	25
M117	M14 x 30	25
M118	M14 x 35	25
M119	M14 x 40	25
M120	M14 x 45	25
M121	M14 x 50	25
M122	M14 x 55	25
M123	M14 x 60	25
M1231	M14 x 65	25
M1232	M14 x 70	25
M1233	M14 x 75	25
M1234	M14 x 80	25
M1236	M14 x 90	25
M1238	M14 x 100	25
-	M14 x 110	-
-	M14 x 120	-
-	M14 x 130	-
-	M14 x 140	-
M1239	M14 x 150	25

ADDITIONAL SIZES AVAILABLE  
UPON REQUEST

### METRIC HEX HEAD CAP SCREWS

#### HEX HEAD CAP SCREWS - COARSE

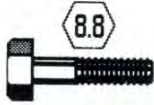

M16 x 2.00 PITCH

STOCK NO.	SIZE	BOX QTY.
M130	M16 x 30mm	25
M131	M16 x 35	25
M132	M16 x 40	25
M133	M16 x 45	25
M134	M16 x 50	25
M135	M16 x 55	25
M1365	M16 x 60	25
M137	M16 x 65	25
M138	M16 x 70	25
M1385	M16 x 75	25
M139	M16 x 80	25
M140	M16 x 90	25
M141	M16 x 100	25
M142	M16 x 110	25
M143	M16 x 120	25
M144	M16 x 130	25
M145	M16 x 140	25
M146	M16 x 150	25
-	M16 x 160	-
-	M16 x 170	-
-	M16 x 180	-
-	M16 x 190	-
-	M16 x 200	-
-	M16 x 210	-
-	M16 x 220	-
-	M16 x 230	-
-	M16 x 240	-
-	M16 x 250	-

M20 x 2.50 PITCH

M148	M20 x 30mm	-
M149	M20 x 35	-
M150	M20 x 40	-
M1505	M20 x 45	-
M151	M20 x 50	-
M1511	M20 x 55	-
M1512	M20 x 60	-
M152	M20 x 65	-
M153	M20 x 70	-
M154	M20 x 75	-
M1541	M20 x 80	-
1542	M20 x 85	-
M1543	M20 x 90	-
M155	M20 x 100	-
M156	M20 x 110	-
M157	M20 x 120	-
M158	M20 x 130	-
M159	M20 x 140	-
M160	M20 x 150	-
M161	M20 x 160	-
-	M20 x 170	-
-	M20 x 180	-
-	M20 x 190	-
-	M20 x 200	-
-	M20 x 210	-
-	M20 x 220	-
-	M20 x 230	-
-	M20 x 240	-
-	M20 x 250	-

#### HEX HEAD CAP SCREWS - COARSE

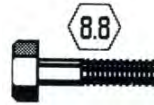

M24 x 3.00 PITCH

STOCK NO.	SIZE	BOX QTY.
168	M24 x 40mm	-
M170	M24 x 50	-
M1702	M24 x 55	-
M1704	M24 x 60	-
M171	M24 x 70	-
M172	M24 x 75	-
M1721	M24 x 80	-
M1724	M24 x 90	-
M173	M24 x 100	-
M174	M24 x 110	-
M175	M24 x 120	-
M176	M24 x 130	-
M177	M24 x 140	-
M178	M24 x 150	-
M179	M24 x 160	-
-	M24 x 170	-
M180	M24 x 180	-
-	M24 x 190	-
-	M24 x 200	-
-	M24 x 210	-
-	M24 x 220	-
-	M24 x 230	-
-	M24 x 240	-
-	M24 x 250	-

#### HEX HEAD CAP SCREWS - FINE

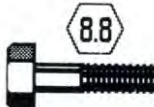

M8 x 1.00 PITCH

STOCK NO.	SIZE	BOX QTY.
M2005	M8 x 20mm	-
M2006	M8 x 25	-
M2007	M8 x 30	-
M2008	M8 x 35	-
M2009	M8 x 40	-
-	M8 x 45	-
-	M8 x 50	-
-	M8 x 60	-
-	M8 x 70	-

M10 x 1.25 PITCH

M2036	M10 x 20mm	-
M2037	M10 x 25	-
M2038	M10 x 30	-
M2039	M10 x 35	-
M2040	M10 x 40	-
M2045	M10 x 45	-
M2050	M10 x 50	-
M2051	M10 x 60	-
-	M10 x 70	-
-	M10 x 80	-
-	M10 x 90	-
M2058	M10 x 100	-

(CONTINUED NEXT COLUMN)

#### HEX HEAD CAP SCREWS - FINE

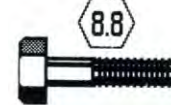

M12 x 1.25 PITCH

STOCK NO.	SIZE	BOX QTY.
M2067	M12 x 25mm	-
M2068	M12 x 30	-
-	M12 x 35	-
M2070	M12 x 40	-
-	M12 x 45	-
M2072	M12 x 50	-
2073	M12 x 55	-
M2074	M12 x 60	-

M12 x 1.50 PITCH

M2090	M12 x 25mm	-
M2091	M12 x 30	-
-	M12 x 35	-
M2092	M12 x 40	-
M2093	M12 x 45	-
M2094	M12 x 50	-
M2095	M12 x 55	-
M2096	M12 x 60	-
-	M12 x 70	-
M2099	M12 x 75	-

M14 x 1.50 PITCH

-	M14 x 30mm	-
-	M14 x 35	-
M2118	M14 x 40	-
-	M14 x 45	-
M2120	M14 x 50	-
M2122	M14 x 60	-
-	M14 x 70	-

M16 x 1.50 PITCH

M2144	M16 x 35mm	-
-	M16 x 40	-
M2147	M16 x 50	-
-	M16 x 60	-
M2152	M16 x 70	-

M18 x 1.50 PITCH

M21573	M18 x 50	-
--------	----------	---

M20 x 1.50 PITCH

M2162	M20 x 40	-
-	M20 x 50	-
-	M20 x 60	-
-	M20 x 70	-
-	M20 x 80	-

**ADDITIONAL SIZES AVAILABLE UPON REQUEST**

**METRIC HEX HEAD CAP SCREWS - GRADE 10.9**

**HEX HEAD CAP SCREWS - COARSE**

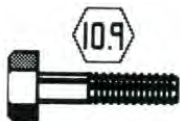

**GRADE 10.9 HEX HEAD CAP SCREWS**

STOCK NO.	SIZE	BOX QTY.
M2232	M6 x 16	-
M22325	M6 x 18	-
M2233	M6 x 20	-
M2234	M6 x 25	-
M2235	M6 x 30	-
M2236	M6 x 35	-
M2237	M6 x 40	-
M2238	M6 x 45	-
M2239	M6 x 50	-
M2240	M6 x 60	-
M2241	M6 x 70	-
-	M6 x 80	-
-	M6 x 90	-
-	M6 x 100	-
-	M6 x 110	-
-	M6 x 120	-
-	M6 x 130	-
M2248	M8 x 16	-
M2249	M8 x 20	-
M2250	M8 x 25	-
M2251	M8 x 30	-
M2252	M8 x 35	-
M2253	M8 x 40	-
M2254	M8 x 45	-
M2255	M8 x 50	-
-	M8 x 55	-
M2257	M8 x 60	-
M2259	M8 x 70	-
-	M8 x 75	-
-	M8 x 80	-
-	M8 x 90	-
-	M8 x 100	-
-	M8 x 110	-
-	M8 x 120	-
-	M8 x 130	-
M2266	M10 x 16	-
M2267	M10 x 20	-
M2269	M10 x 25	-
M2270	M10 x 30	-
M2271	M10 x 35	-
M2272	M10 x 40	-
M2273	M10 x 45	-
M2274	M10 x 50	-
M2275	M10 x 55	-
M2276	M10 x 60	-
M2277	M10 x 65	-
M2278	M10 x 70	-
M2279	M10 x 75	-
M2280	M10 x 80	-
M2282	M10 x 90	-
M2284	M10 x 100	-
M2285	M10 x 110	-
-	M10 x 120	-
-	M10 x 130	-
M2287	M12 x 20	-
M2288	M12 x 25	-
M2289	M12 x 30	-
M2290	M12 x 35	-

(CONTINUED NEXT COLUMN)

**HEX HEAD CAP SCREWS - COARSE**



**GRADE 10.9 HEX HEAD CAP SCREWS**

STOCK NO.	SIZE	BOX QTY.
M2291	M12 x 40	-
M2292	M12 x 45	-
M2293	M12 x 50	-
M2294	M12 x 55	-
M2295	M12 x 60	-
M2296	M12 x 65	-
M2297	M12 x 70	-
M2299	M12 x 80	-
M2301	M12 x 90	-
M2302	M12 x 100	-
M2303	M12 x 110	-
M2304	M12 x 120	-
-	M12 x 130	-
-	M12 x 140	-
-	M12 x 150	-
-	M14 x 30	-
-	M14 x 35	-
-	M14 x 40	-
-	M14 x 45	-
-	M14 x 50	-
-	M14 x 55	-
-	M14 x 60	-
-	M14 x 70	-
-	M14 x 80	-
-	M14 x 90	-
-	M14 x 100	-
-	M14 x 110	-
-	M14 x 120	-
-	M14 x 130	-
-	M14 x 140	-
-	M14 x 150	-
-	M14 x 160	-
M2310	M16 x 30	-
M2311	M16 x 35	-
M2312	M16 x 40	-
M2313	M16 x 45	-
M2314	M16 x 50	-
-	M16 x 55	-
M2316	M16 x 60	-
-	M16 x 65	-
M2318	M16 x 70	-
M2319	M16 x 75	-
M2320	M16 x 80	-
M2321	M16 x 90	-
M2322	M16 x 100	-
M2323	M16 x 110	-
M2324	M16 x 120	-
M2325	M16 x 130	-
M2326	M16 x 140	-
M2327	M16 x 150	-
-	M16 x 160	-
M2343	M20 x 30	-
M2344	M20 x 35	-
M2345	M20 x 40	-
M2346	M20 x 45	-
M2347	M20 x 50	-
M2349	M20 x 60	-
M2351	M20 x 70	-

(CONTINUED NEXT COLUMN)

**HEX HEAD CAP SCREWS - COARSE**



**GRADE 10.9 HEX HEAD CAP SCREWS**

STOCK NO.	SIZE	BOX QTY.
M2353	M20 x 80	-
M2355	M20 x 90	-
M2356	M20 x 100	-
M2357	M20 x 110	-
M2358	M20 x 120	-
M2360	M20 x 130	-
M2361	M20 x 140	-
M2362	M20 x 150	-
M2363	M20 x 160	-
M2364	M20 x 170	-
M23642	M20 x 180	-
M23644	M20 x 190	-
M2365	M20 x 200	-
-	M20 x 210	-
-	M20 x 220	-
-	M20 x 230	-
-	M20 x 240	-
M2374	M24 x 40	-
M2376	M24 x 50	-
M2378	M24 x 60	-
M2379	M24 x 70	-
M2380	M24 x 80	-
M2381	M24 x 90	-
M2382	M24 x 100	-
M2383	M24 x 110	-
M2384	M24 x 120	-
M2385	M24 x 130	-
M2386	M24 x 140	-
M2387	M24 x 150	-
M2388	M24 x 160	-
M2389	M24 x 170	-
M2390	M24 x 180	-
M2391	M24 x 190	-
M2392	M24 x 200	-
-	M24 x 210	-
-	M24 x 220	-
-	M24 x 230	-
-	M24 x 240	-
-	M24 x 250	-
-	M30 x 50	-
M2422	M30 x 60	-
-	M30 x 70	-
-	M30 x 80	-
-	M30 x 90	-
-	M30 x 100	-
-	M30 x 110	-
-	M30 x 120	-
-	M30 x 130	-
-	M30 x 140	-
-	M30 x 150	-
-	M30 x 160	-
-	M30 x 170	-
-	M30 x 180	-
-	M30 x 190	-
-	M30 x 200	-
-	M30 x 210	-
-	M30 x 220	-
-	M30 x 230	-
-	M30 x 240	-

## METRIC SOCKET CAP SCREWS - GRADE 12.9

### SOCKET HEAD CAP SCREWS

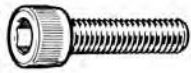

M2 x 0.4 PITCH

STOCK NO.	SIZE	BOX QTY.
M260	M2 x 3mm	100
M261	M2 x 4	100
M262	M2 x 5	100
M263	M2 x 6	100
M264	M2 x 8	100
M265	M2 x 10	100
M266	M2 x 12	100
M267	M2 x 14	100
M2675	M2 x 16	100
M268	M2 x 20	100

M2.5 x 0.45 PITCH

M269	M2.5 x 3mm	100
M270	M2.5 x 4	100
M2701	M2.5 x 5	100
M2702	M2.5 x 6	100
M271	M2.5 x 8	100
M272	M2.5 x 10	100
M273	M2.5 x 12	100
M274	M2.5 x 14	100
M275	M2.5 x 16	100
M276	M2.5 x 18	100
M277	M2.5 x 20	100
M278	M2.5 x 25	100

M3 x 0.5 PITCH

M282	M3 x 4mm	100
M283	M3 x 5	100
M284	M3 x 6	100
M285	M3 x 8	100
M286	M3 x 10	100
M287	M3 x 12	100
M288	M3 x 14	100
M2885	M3 x 15	100
M289	M3 x 16	100
M2895	M3 x 18	100
M290	M3 x 20	100
M291	M3 x 22	100
M292	M3 x 25	100
M293	M3 x 30	100
M294	M3 x 35	100
M295	M3 x 40	100
M296	M3 x 45	100
M297	M3 x 50	100

M4 x 0.7 PITCH

M299	M4 x 5mm	100
M300	M4 x 6	100
M3005	M4 x 8	100
M301	M4 x 10	100
M302	M4 x 12	100
M3025	M4 x 14	100
M3027	M4 x 15	100
M303	M4 x 16	100
M3035	M4 x 18	100
M304	M4 x 20	100
M3045	M4 x 22	100
M305	M4 x 25	100

(CONTINUED NEXT COLUMN)

### SOCKET HEAD CAP SCREWS

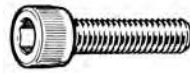

STOCK NO.	SIZE	BOX QTY.
M306	M4 x 30	100
M307	M4 x 35	100
M308	M4 x 40	100
M3085	M4 x 45	100
M309	M4 x 50	100
M3092	M4 x 60	100
M3094	M4 x 70	100
M3095	M4 x 80	100

M5 x 0.8 PITCH

M3098	M5 x 6mm	100
M3099	M5 x 8	100
M310	M5 x 10	100
M311	M5 x 12	100
M312	M5 x 14	100
M3122	M5 x 15	100
M3124	M5 x 16	100
M3125	M5 x 18	100
M313	M5 x 20	100
M3132	M5 x 22	100
M3135	M5 x 25	100
M314	M5 x 30	100
M3145	M5 x 35	100
M315	M5 x 40	100
M3155	M5 x 45	100
M316	M5 x 50	100
M317	M5 x 55	100
M3175	M5 x 60	100
M318	M5 x 65	100
M319	M5 x 70	100
M320	M5 x 75	100
M321	M5 x 80	100
M322	M5 x 90	100
M323	M5 x 100	100

M6 x 1.0 PITCH

M327	M6 x 8mm	100
M328	M6 x 10	100
M329	M6 x 12	100
M330	M6 x 14	100
M3301	M6 x 16	100
M3302	M6 x 18	100
M331	M6 x 20	100
M3315	M6 x 22	100
M332	M6 x 25	100
M333	M6 x 30	100
M334	M6 x 35	100
M335	M6 x 40	100
M3354	M6 x 45	100
M336	M6 x 50	100
M3365	M6 x 55	100
M337	M6 x 60	100
M338	M6 x 65	100
M339	M6 x 70	100
M340	M6 x 75	100
M341	M6 x 80	100
M343	M6 x 90	100
M344	M6 x 100	100
M3441	M6 x 110	100
M3442	M6 x 120	100
M3445	M6 x 140	50
M3447	M6 x 150	50

(CONTINUED NEXT COLUMN)

### SOCKET HEAD CAP SCREWS



M8 x 1.25 PITCH

STOCK NO.	SIZE	BOX QTY.
M345	M8 x 10mm	100
M3455	M8 x 12	100
M3457	M8 x 14	100
M3459	M8 x 15	100
M346	M8 x 16	100
M3461	M8 x 18	100
M3462	M8 x 20	100
M3465	M8 x 22	100
M347	M8 x 25	100
M348	M8 x 30	100
M349	M8 x 35	100
M350	M8 x 40	100
M3505	M8 x 45	100
M351	M8 x 50	100
M3515	M8 x 55	100
M352	M8 x 60	100
M3525	M8 x 65	100
M353	M8 x 70	100
M3535	M8 x 75	100
M354	M8 x 80	100
M355	M8 x 90	100
M356	M8 x 100	100
M3565	M8 x 110	100
M357	M8 x 120	100
M358	M8 x 130	100
M359	M8 x 140	50
M3591	M8 x 150	50
M3592	M8 x 160	50
3593	M8 x 170	50
M3594	M8 x 180	50
-	M8 x 190	-
M3595	M8 x 200	50

M10 x 1.5 PITCH

M3598	M10 x 10mm	100
M3599	M10 x 12	100
M35991	M10 x 14	100
M35993	M10 x 15	100
M360	M10 x 16	100
M3605	M10 x 18	100
M361	M10 x 20	100
M3615	M10 x 22	100
M362	M10 x 25	100
M363	M10 x 30	100
M364	M10 x 35	100
M365	M10 x 40	100
M366	M10 x 45	100
M367	M10 x 50	100
M368	M10 x 55	100
M369	M10 x 60	100
M3695	M10 x 65	100
M370	M10 x 70	100
M3705	M10 x 75	100
M371	M10 x 80	100
M372	M10 x 90	50
M373	M10 x 100	50
M374	M10 x 110	50
M3745	M10 x 120	50
M375	M10 x 130	50
M376	M10 x 140	50
M3765	M10 x 150	50
M377	M10 x 160	25
-	M10 x 170	-
M3775	M10 x 180	25
-	M10 x 190	-
M378	M10 x 200	25

(CONTINUED NEXT PAGE)

**METRIC SOCKET CAP SCREWS - GRADE 12.9**

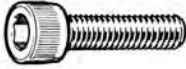
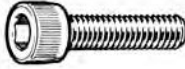
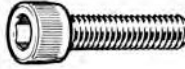
SOCKET HEAD CAP SCREWS				SOCKET HEAD CAP SCREWS				SOCKET HEAD CAP SCREWS			
											
M12 x 1.75 PITCH				M16 x 2.0 PITCH				M20 x 2.5 PITCH			
STOCK NO.	SIZE		BOX QTY.	STOCK NO.	SIZE		BOX QTY.	STOCK NO.	SIZE		BOX QTY.
M379	M12 x 12mm		50	M400	M16 x 20mm		25	M415	M20 x 30mm		25
M3791	M12 x 14		50	M4005	M16 x 25		25	M4152	M20 x 35		25
M3792	M12 x 15		50	M4006	M16 x 30		25	M4155	M20 x 40		25
M3795	M12 x 16		50	M401	M16 x 35		25	M4156	M20 x 45		25
M3797	M12 x 18		50	M4015	M16 x 40		25	M4158	M20 x 50		25
M380	M12 x 20		50	M402	M16 x 45		25	M416	M20 x 55		25
M3805	M12 x 22		50	M403	M16 x 50		25	M4162	M20 x 60		25
M381	M12 x 25		50	M4035	M16 x 55		25	M4163	M20 x 65		25
M382	M12 x 30		50	M404	M16 x 60		25	M417	M20 x 70		25
M383	M12 x 35		50	M4045	M16 x 65		25	M418	M20 x 75		25
M384	M12 x 40		50	M405	M16 x 70		25	M419	M20 x 80		25
M385	M12 x 45		50	M4055	M16 x 75		25	M420	M20 x 90		25
M386	M12 x 50		50	M406	M16 x 80		25	M421	M20 x 100		25
M3865	M12 x 55		50	M4061	M16 x 90		25	M4211	M20 x 110		25
M387	M12 x 60		50	M407	M16 x 100		25	M4212	M20 x 120		25
M388	M12 x 65		50	M4071	M16 x 110		25	M4213	M20 x 130		25
M389	M12 x 70		25	M4072	M16 x 120		25	M4214	M20 x 140		10
M3895	M12 x 75		25	M4073	M16 x 130		25	M4216	M20 x 150		10
M390	M12 x 80		25	M4074	M16 x 140		10	M4218	M20 x 160		10
M391	M12 x 90		25	M4075	M16 x 150		10	M4219	M20 x 170		10
M392	M12 x 100		25	M4076	M16 x 160		10	M4220	M20 x 180		10
M3925	M12 x 110		25	-	M16 x 170		-	M4221	M20 x 190		10
M393	M12 x 120		25	M4077	M16 x 180		10	M4222	M20 x 200		10
M3931	M12 x 130		25	-	M16 x 190		-	-	M20 x 210		-
M3932	M12 x 140		25	M4079	M16 x 200		10	M4224	M20 x 220		5
M3933	M12 x 150		25	-	M16 x 210		-	M4225	M20 x 230		5
M3934	M12 x 160		10	M4081	M16 x 220		10	M4226	M20 x 240		5
-	M12 x 170		-	-	M16 x 230		-	-	M20 x 250		-
M3936	M12 x 180		10	M4082	M16 x 240		10	M4228	M20 x 260		5
-	M12 x 190		-	-	M16 x 250		-	-	M20 x 270		-
M3938	M12 x 200		10	M40821	M16 x 260		10	M4229	M20 x 280		5
-	M12 x 210		-	-	M16 x 270		-	-	M20 x 290		-
M3939	M12 x 220		10	M40822	M16 x 280		10	M4230	M20 x 300		5
-	M12 x 230		-	-	M16 x 290		-	-	M20 x 310		-
M394	M12 x 240		10	M40823	M16 x 300		10	M4231	M20 x 320		5
-	M12 x 250		-					-	M20 x 330		-
M3941	M12 x 260		10					M4232	M20 x 340		5
M14 x 2.0 PITCH				M18 x 2.5 PITCH				M22 x 2.5 PITCH			
M3947	M14 x 25mm		50	M40847	M18 x 30mm		25	M434	M22 x 40mm		10
M395	M14 x 30		50	M40846	M18 x 35		25	M4341	M22 x 45		10
M3951	M14 x 35		50	M40847	M18 x 40		25	M4342	M22 x 50		10
M3952	M14 x 40		50	M40848	M18 x 45		25	M4344	M22 x 55		10
M3953	M14 x 45		50	M40849	M18 x 50		25	M4351	M22 x 60		10
M3954	M14 x 50		50	M4085	M18 x 55		25	M4352	M22 x 65		10
M3955	M14 x 55		50	M4086	M18 x 60		25	M4353	M22 x 70		10
M3956	M14 x 60		25	M4087	M18 x 65		25	M4354	M22 x 75		10
M3957	M14 x 65		25	M4088	M18 x 70		25	M4355	M22 x 80		10
M3958	M14 x 70		25	M4089	M18 x 75		25	M4357	M22 x 90		10
M3959	M14 x 75		25	M4090	M18 x 80		25	M43575	M22 x 100		10
M3960	M14 x 80		25	M4091	M18 x 90		25	M4358	M22 x 110		10
M3961	M14 x 90		25	M4092	M18 x 100		10	M4359	M22 x 120		10
M3962	M14 x 100		25	M4093	M18 x 110		10	M43591	M22 x 130		10
M39625	M14 x 110		25	M4094	M18 x 120		10	M43592	M22 x 140		10
M3963	M14 x 120		25	M4095	M18 x 130		10	M436	M22 x 150		10
M3964	M14 x 130		25	M4096	M18 x 140		10	M4360	M22 x 160		10
M3965	M14 x 140		25	M4097	M18 x 150		10	-	M22 x 170		-
M3966	M14 x 150		25	M4098	M18 x 160		10	M4361	M22 x 180		10
M3967	M14 x 160		25	-	M18 x 170		-	-	M22 x 190		-
-	M14 x 170		-	M4099	M18 x 180		10	-	M22 x 200		10
-	M14 x 180		-	-	M18 x 190		-	-	M22 x 210		-
-	M14 x 190		-	M410	M18 x 200		10	M4362	M22 x 220		5
-	M14 x 200		-	-	M18 x 210		-	-	M22 x 230		-
-	M14 x 210		-	-	M18 x 220		-	M4363	M22 x 240		5
-	M14 x 220		-					-	M22 x 250		-

(CONTINUED NEXT COLUMN)

(CONTINUED NEXT COLUMN)

(CONTINUED NEXT PAGE)

**METRIC SOCKET CAP SCREWS - GRADE 12.9**

**SOCKET HEAD CAP SCREWS**

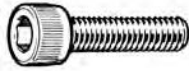

**M24 x 3.0 PITCH**

STOCK NO.	SIZE	BOX QTY.
M437	M24 x 40mm	10
M4375	M24 x 45	10
M438	M24 x 50	10
M439	M24 x 55	10
M440	M24 x 60	10
M4405	M24 x 65	10
M441	M24 x 70	10
M442	M24 x 75	10
M443	M24 x 80	10
M444	M24 x 90	10
M445	M24 x 100	10
M446	M24 x 110	10
M449	M24 x 120	10
M450	M24 x 130	10
M451	M24 x 140	10
M452	M24 x 150	10
M453	M24 x 160	10
M454	M24 x 170	10
M455	M24 x 180	10
-	M24 x 190	-
M457	M24 x 200	5
-	M24 x 210	-
M4570	M24 x 220	5
-	M24 x 230	-
M4571	M24 x 240	5
-	M24 x 250	-
M4572	M24 x 260	5
-	M24 x 270	-
M4573	M24 x 280	5
-	M24 x 290	-
M4574	M24 x 300	5
-	M24 x 310	-
M4575	M24 x 320	1
-	M24 x 330	-
M4576	M24 x 340	1

**M27 x 3.0 PITCH**

M460	M27 x 50mm	5
M461	M27 x 60	5
M462	M27 x 70	5
M463	M27 x 80	5
M464	M27 x 90	5
M465	M27 x 100	5
M466	M27 x 110	5
M467	M27 x 120	5
M468	M27 x 130	5
M469	M27 x 140	5
M470	M27 x 150	5
M472	M27 x 160	5
-	M27 x 170	-
M475	M27 x 180	5
-	M27 x 190	-
M4750	M27 x 200	1
-	M27 x 210	-
M4751	M27 x 220	1
-	M27 x 230	-
M4752	M27 x 240	1
-	M27 x 250	-
M4753	M27 x 260	1
-	M27 x 270	-
M4754	M27 x 280	1
-	M27 x 290	-
M4755	M27 x 300	1
-	M27 x 310	-
-	M27 x 320	-

(CONTINUED NEXT COLUMN)

**SOCKET HEAD CAP SCREWS**

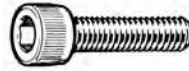

**M30 x 3.5 PITCH**

STOCK NO.	SIZE	BOX QTY.
M476	M30 x 50mm	1
M477	M30 x 60	1
4775	M30 x 65	1
M478	M30 x 70	1
M480	M30 x 80	1
M482	M30 x 90	1
M483	M30 x 100	1
M484	M30 x 110	1
M485	M30 x 120	1
M4850	M30 x 130	1
M48501	M30 x 140	1
M48502	M30 x 150	1
M48503	M30 x 160	1
-	M30 x 170	-
M48504	M30 x 180	1
-	M30 x 190	-
M48505	M30 x 200	1
-	M30 x 210	-
M48506	M30 x 220	1
-	M30 x 230	-
M48507	M30 x 240	1
-	M30 x 250	-
M48508	M30 x 260	1
-	M30 x 270	-
M48509	M30 x 280	1
-	M30 x 290	-
M485105	M30 x 300	1
-	M30 x 300	-
-	M30 x 320	1
-	M30 x 330	-
-	M30 x 340	-
-	M30 x 350	-
-	M30 x 360	1
-	M30 x 370	-
-	M30 x 380	1
-	M30 x 390	-
-	M30 x 400	1

(CONTINUED NEXT COLUMN)

**IF YOU DON'T SEE SOMETHING HERE YOU NEED, GIVE US A CALL**



**WE WILL DO OUR BEST TO FIND IT FOR YOU.**

**SOCKET HEAD CAP SCREWS**

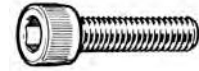

**M36 x 4.0 PITCH**

STOCK NO.	SIZE	BOX QTY.
485111	M36 x 65mm	1
M48512	M36 x 70	1
M485122	M36 x 75	1
M485124	M36 x 80	1
M485126	M36 x 90	1
M48514	M36 x 100	1
M48515	M36 x 110	1
M48516	M36 x 120	1
M48517	M36 x 130	1
M48518	M36 x 140	1
M48519	M36 x 150	1
M485195	M36 x 160	1
-	M36 x 170	-
M48520	M36 x 180	1
-	M36 x 190	-
M48521	M36 x 200	1
-	M36 x 210	-
M485215	M36 x 220	1
-	M36 x 230	-
M485216	M36 x 240	1
-	M36 x 250	-
M485217	M36 x 260	1
-	M36 x 270	-
M485218	M36 x 300	1
-	M36 x 320	1
-	M36 x 340	1
-	M36 x 360	1
-	M36 x 380	1
-	M36 x 400	1

**M42 x 4.5 PITCH**

M48523	M42 x 80mm	1
M48524	M42 x 90	1
M48525	M42 x 100	1
M48526	M42 x 110	1
M48527	M42 x 120	1
M48528	M42 x 130	1
M48529	M42 x 140	1
M48530	M42 x 150	1
M48531	M42 x 160	1
M48532	M42 x 180	1
M48533	M42 x 200	1
M485331	M42 x 220	1
M485332	M42 x 240	1
M485338	M42 x 260	1
M48536	M42 x 280	1
M48537	M42 x 300	1
M48538	M42 x 320	1
M48539	M42 x 340	1
M48540	M42 x 360	1
M48541	M42 x 380	1
M48542	M42 x 400	1



**METRIC SOCKET CAP SCREWS - GRADE 12.9**

**SOCKET HEAD CAP SCREWS - FINE**

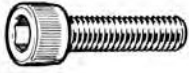

**M8 x 1.0 PITCH**

M35951	M8	x	20mm	100
M35952	M8	x	25	100
M35953	M8	x	30	100
M35954	M8	x	35	100
M35956	M8	x	40	100
M35957	M8	x	45	100
M35958	M8	x	50	100
M35959	M8	x	60	100
M3596	M8	x	80	100

**M10 x 1.25 PITCH**

M3781	M10	x	20	100
M3782	M10	x	25	100
M3783	M10	x	30	100
M3784	M10	x	40	100
M3785	M10	x	50	50
M3786	M10	x	55	50
M3787	M10	x	60	50
M3788	M10	x	70	50
M3789	M10	x	75	50
M37891	M10	x	80	50

**M12 x 1.25 PITCH**

M39411	M12	x	25	50
M39412	M12	x	30	50
M39413	M12	x	40	50
M39414	M12	x	50	50
M39415	M12	x	55	50
M39416	M12	x	60	50
M39417	M12	x	70	50
M39418	M12	x	80	25

**M16 x 1.5 PITCH**

M40831	M16	x	25mm	25
M40832	M16	x	30	25
M40833	M16	x	40	25
M40834	M16	x	50	25
M40835	M16	x	60	25
M40836	M16	x	80	25

SIMON WAS AN INVETERATE FISHERMAN, WELL KNOWN FOR EXAGGERATING THE SIZE OF "THE ONE THAT GOT AWAY." BUT THERE CAME A DAY WHEN HE ACTUALLY CAUGHT TWO ENORMOUS FLOUNDERS. HE IMMEDIATELY INVITED A FEW FRIENDS OVER TO DINE, THEN TRIED TO FIGURE OUT HOW BEST TO SERVE THE FISH. "IF I USE BOTH," HE TOLD HIS WIFE, "IT WILL SEEM OSTENTATIOUS."

"WHY NOT SERVE A PIECE OF EACH?" SHE SUGGESTED.

"NO, IF I CUT THEM UP, NOBODY WILL BELIEVE I CAUGHT TWO GIANT FLOUNDERS." SIMON RACKED HIS BRAIN. THEN HE HAD AN IDEA. THE GUESTS WERE SEATED AT THE TABLE WHEN THEIR HOST STRODE IN WITH A PLATTER, HOLDING THE BIGGEST FLOUNDER THEY'D EVER SEEN. SUDDENLY SIMON STUMBLED AND FELL. EVERYONE CRIED OUT IN DISMAY AS THE FISH CRASHED TO THE FLOOR, BUT SIMON QUICKLY BRUSHED HIMSELF OFF.

"DEAR," HE CALLED OUT TO HIS WIFE, "BRING IN THE OTHER FLOUNDER."

**GIVE  
US  
A  
CALL**

CALL US FOR ALL YOUR NEEDS  
**855-785-TOOL**



**FOR  
ALL  
YOUR  
NEEDS!**

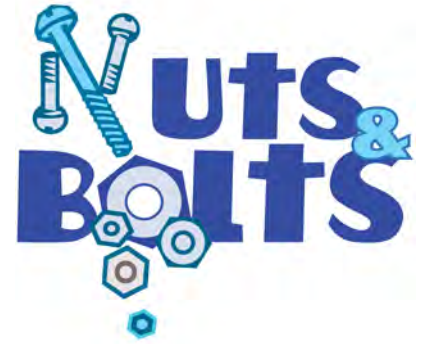

THIS SPACE RESERVED FOR FUTURE  
 METRIC FASTENER PRODUCTS

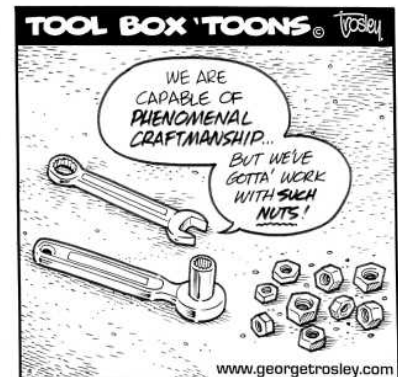

## METRIC SOCKET CAP SCREWS (12.9)

### FLAT HEAD SOCKET CAP SCREWS

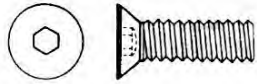

#### M2 x 0.4 PITCH

STOCK NO.	SIZE	BOX QTY.
M4857	M2 x 4mm	100
M48570	M2 x 5	100
M48571	M2 x 6	100
M48572	M2 x 8	100
M48573	M2 x 10	100
M48574	M2 x 12	100
M48575	M2 x 16	100

#### M2.5 x 0.45 PITCH

M48577	M2.5 x 4mm	100
M48578	M2.5 x 5	100
M48579	M2.5 x 6	100
M48580	M2.5 x 8	100
M48581	M2.5 x 10	100
M48582	M2.5 x 12	100
M485821	M2.5 x 16	100
M485822	M2.5 x 20	100

#### M3 x 0.5 PITCH

M48584	M3 x 5mm	100
M48585	M3 x 6	100
M485850	M3 x 8	100
M48586	M3 x 10	100
M48587	M3 x 12	100
M485871	M3 x 14	100
M485873	M3 x 15	100
M48588	M3 x 16	100
M48589	M3 x 18	100
M48590	M3 x 20	100
M48591	M3 x 25	100
M48592	M3 x 30	100
M48593	M3 x 35	100
M48594	M3 x 40	100

#### M4 x 0.7 PITCH

M486	M4 x 6mm	100
M487	M4 x 8	100
M488	M4 x 10	100
M489	M4 x 12	100
M490	M4 x 14	100
M4905	M4 x 15	100
M491	M4 x 16	100
M4915	M4 x 18	100
M492	M4 x 20	100
M494	M4 x 25	100
M495	M4 x 30	100
M496	M4 x 35	100
M497	M4 x 40	100
M4972	M4 x 50	100
M4973	M4 x 60	100
M4974	M4 x 70	100

#### M5 x 0.8 PITCH

M498	M5 x 8mm	100
M499	M5 x 10	100
M500	M5 x 12	100
M501	M5 x 14	100
M5015	M5 x 15	100
M502	M5 x 16	100

(CONTINUED NEXT COLUMN)

### FLAT HEAD SOCKET CAP SCREWS

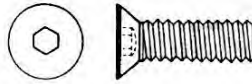

STOCK NO.	SIZE	BOX QTY.
M503	M5 x 18	100
M504	M5 x 20	100
M505	M5 x 25	100
M506	M5 x 30	100
M507	M5 x 35	100
M508	M5 x 40	100
M509	M5 x 45	100
M510	M5 x 50	100

#### M6 x 1.0 PITCH

M512	M6 x 8mm	100
M513	M6 x 10	100
M514	M6 x 12	100
M515	M6 x 14	100
M5155	M6 x 15	100
M516	M6 x 16	100
M5165	M6 x 18	100
M517	M6 x 20	100
M518	M6 x 25	100
M5185	M6 x 30	100
M519	M6 x 35	100
M5192	M6 x 40	100
M5194	M6 x 45	100
M520	M6 x 50	100
M5202	M6 x 60	100
M5204	M6 x 70	100
M5206	M6 x 80	100

#### M8 x 1.25 PITCH

M521	M8 x 8mm	100
M5213	M8 x 10	100
M5215	M8 x 12	100
M5216	M8 x 14	100
M5217	M8 x 15	100
M5218	M8 x 16	100
M5219	M8 x 18	100
M522	M8 x 20	100
M523	M8 x 25	100
M524	M8 x 30	100
M525	M8 x 35	100
M5251	M8 x 40	100
M5261	M8 x 45	100
M5262	M8 x 50	100
M5264	M8 x 55	100
M527	M8 x 60	100
M5270	M8 x 70	100
M5271	M8 x 80	100
M5272	M8 x 90	100
M5273	M8 x 100	100
M5274	M8 x 110	100
M5275	M8 x 120	100

#### M10 x 1.5 PITCH

M5276	M10 x 12mm	100
M5277	M10 x 14	100
M5278	M10 x 15	100
M5279	M10 x 16	100
M52795	M10 x 18	100
M528	M10 x 20	100
M529	M10 x 25	100
M530	M10 x 30	100

(CONTINUED NEXT COLUMN)

### FLAT HEAD SOCKET CAP SCREWS

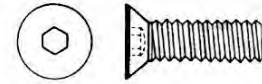

STOCK NO.	SIZE	BOX QTY.
M531	M10 x 35	100
M5315	M10 x 40	100
M532	M10 x 45	100
M5325	M10 x 50	100
M5326	M10 x 55	100
M5327	M10 x 60	100
M5328	M10 x 65	100
M5329	M10 x 70	100
M5330	M10 x 75	100
M5331	M10 x 80	50
M5333	M10 x 90	50
M5335	M10 x 100	50
M5336	M10 x 110	50
M5337	M10 x 120	50

#### M12 x 1.75 PITCH

M535	M12 x 20mm	100
M5351	M12 x 25	100
M5353	M12 x 30	100
M5355	M12 x 35	100
M536	M12 x 40	100
M537	M12 x 45	100
M538	M12 x 50	100
M539	M12 x 55	50
M540	M12 x 60	50
M5401	M12 x 70	50
M5403	M12 x 80	50
M5405	M12 x 90	50
M5407	M12 x 100	50
M5409	M12 x 110	50
M541	M12 x 120	50

#### M14 x 2.0 PITCH

M5411	M14 x 25mm	50
M5412	M14 x 30	50
M5413	M14 x 35	50
M5414	M14 x 40	50
-	M14 x 45	-
M5415	M14 x 50	50
M5416	M14 x 55	50
M5417	M14 x 60	25
M5418	M14 x 65	25

#### M16 x 2.0 PITCH

M542	M16 x 25mm	50
M5423	M16 x 30	50
M5425	M16 x 35	50
M5426	M16 x 40	50
M5427	M16 x 45	50
M5428	M16 x 50	50
M5429	M16 x 55	50
M543	M16 x 60	50
M5431	M16 x 70	25
M5432	M16 x 80	25
M5433	M16 x 90	25
M5434	M16 x 100	25
M5435	M16 x 110	25
M5436	M16 x 120	25
M5437	M16 x 130	25
M5438	M16 x 140	10
M5439	M16 x 150	10

(CONTINUED NEXT PAGE)



**METRIC SOCKET CAP SCREWS (12.9), FLAT AND BUTTON**

**FLAT HEAD SOCKET CAP SCREWS**

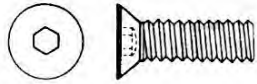

**M20 x 2.5 PITCH**

STOCK NO.	SIZE	BOX QTY.
M544	M20 x 30mm	25
M5441	M20 x 35	25
M54412	M20 x 40	25
M54413	M20 x 45	25
M54414	M20 x 50	25
M54415	M20 x 55	25
M54416	M20 x 60	25
M54417	M20 x 70	25
M54418	M20 x 80	25
M54419	M20 x 90	25
M544191	M20 x 100	25
M5448	M20 x 110	25
M5450	M20 x 120	25
-	M20 x 130	25
M5451	M20 x 140	10
-	M20 x 150	10
M5452	M20 x 160	10
-	M20 x 170	10
M5454	M20 x 180	10
-	M20 x 190	10
M5455	M20 x 200	10

**BUTTON HEAD SOCKET CAP SCREWS**

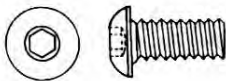

**M2 x 0.4 PITCH**

STOCK NO.	SIZE	BOX QTY.
M54550	M2 x 3mm	100
M54551	M2 x 4	100
M54552	M2 x 5	100
M54553	M2 x 6	100
M54554	M2 x 8	100
M54555	M2 x 10	100
M54556	M2 x 12	100
M54557	M2 x 16	100

**M2.5 x 0.45 PITCH**

M54558	M2.5 x 3mm	100
M54559	M2.5 x 4	100
M545590	M2.5 x 5	100
M545591	M2.5 x 6	100
M545592	M2.5 x 8	100
M545593	M2.5 x 10	100
M545594	M2.5 x 12	100
M545595	M2.5 x 16	100
M545596	M2.5 x 20	100

(CONTINUED NEXT COLUMN)

**BUTTON HEAD SOCKET CAP SCREWS**

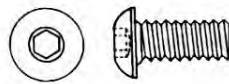

**M3 x 0.5 PITCH**

STOCK NO.	SIZE	BOX QTY.
M546	M3 x 5mm	100
M5460	M3 x 6	100
M5461	M3 x 8	100
M5462	M3 x 10	100
M5463	M3 x 12	100
M54635	M3 x 14	100
M5464	M3 x 16	100
M5465	M3 x 20	100
M5466	M3 x 25	100

**M4 x 0.7 PITCH**

M5471	M4 x 6mm	100
M5472	M4 x 8	100
M5473	M4 x 10	100
M5474	M4 x 12	100
M54745	M4 x 14	100
M5475	M4 x 16	100
M5476	M4 x 20	100
M5478	M4 x 25	100
M54783	M4 x 30	100
M54785	M4 x 35	100
M54787	M4 x 40	100

**M5 x 0.8 PITCH**

M548	M5 x 6mm	100
M5481	M5 x 8	100
M5482	M5 x 10	100
M5483	M5 x 12	100
M54835	M5 x 14	100
M5484	M5 x 16	100
M5485	M5 x 20	100
M5486	M5 x 25	100
M5487	M5 x 30	100
M5488	M5 x 35	100
M5489	M5 x 40	100

**M6 x 1.0 PITCH**

M5495	M6 x 8mm	100
M5496	M6 x 10	100
M5497	M6 x 12	100
M54975	M6 x 14	100
M5498	M6 x 16	100
M5499	M6 x 20	100
M5500	M6 x 25	100
M5501	M6 x 30	100
M5502	M6 x 35	100
M5503	M6 x 40	100
M5504	M6 x 45	100
M5505	M6 x 50	100
M5506	M6 x 60	100

(CONTINUED NEXT COLUMN)

**BUTTON HEAD SOCKET CAP SCREWS**

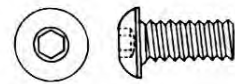

**M8 x 1.25 PITCH**

STOCK NO.	SIZE	BOX QTY.
M5517	M8 x 10mm	100
M5518	M8 x 12	100
M55185	M8 x 14	100
M5519	M8 x 16	100
M5520	M8 x 20	100
M5521	M8 x 25	100
M5522	M8 x 30	100
M5523	M8 x 35	100
M5524	M8 x 40	100
M5525	M8 x 45	100
M5526	M8 x 50	100
M5528	M8 x 60	100
M5529	M8 x 70	100
M55291	M8 x 80	100

**M10 x 1.5 PITCH**

M55295	M10 x 14mm	100
M5530	M10 x 16	100
M5531	M10 x 20	100
M5532	M10 x 25	100
M5533	M10 x 30	100
M5534	M10 x 35	100
M5535	M10 x 40	100
M5536	M10 x 45	100
M5537	M10 x 50	50
M5538	M10 x 60	50
M5539	M10 x 70	50
M5540	M10 x 80	50

**M12 x 1.75 PITCH**



M5550	M12 x 16mm	100
M5551	M12 x 20	100
M5552	M12 x 25	100
M5553	M12 x 30	100
M5554	M12 x 35	100
M5555	M12 x 40	100
M5556	M12 x 45	100
M5557	M12 x 50	100
M5558	M12 x 60	50
M5559	M12 x 70	50
M556	M12 x 80	50



**METRIC SOCKET CAP SCREWS (12.9), LOW HEAD, AND DOWEL PINS**

LOW HEAD SOCKET CAP SCREWS			
			
<b>M4 x 0.7 PITCH</b>			
STOCK NO.	SIZE		BOX QTY.
M558	M4 x 6mm		100
M559	M4 x 8		100
M5600	M4 x 10		100
M5601	M4 x 12		100
M5602	M4 x 16		100
M5603	M4 x 20		100
M5604	M4 x 25		100
M5605	M4 x 30		100
<b>M5 x 0.8 PITCH</b>			
M5631	M5 x 8mm		100
M5632	M5 x 10		100
M5633	M5 x 12		100
M5634	M5 x 16		100
M5635	M5 x 20		100
M5637	M5 x 25		100
M5638	M5 x 30		100
<b>M6 x 1.0 PITCH</b>			
M5646	M6 x 8mm		100
M56461	M6 x 10		100
M5647	M6 x 12		100
M56471	M6 x 14		100
M5648	M6 x 16		100
M5650	M6 x 20		100
M5651	M6 x 25		100
M5652	M6 x 30		100
M5653	M6 x 35		100
M5654	M6 x 40		100
M5655	M6 x 50		100
<b>M8 x 1.25 PITCH</b>			
M5661	M8 x 10mm		100
M5662	M8 x 12		100
M5663	M8 x 16		100
M56632	M8 x 20		100
M5665	M8 x 25		100
M5666	M8 x 30		100
M5667	M8 x 35		100
M5668	M8 x 40		100
M5669	M8 x 45		100
M5670	M8 x 50		100
<b>M10 x 1.5 PITCH</b>			
M56701	M10 x 12mm		100
M5671	M10 x 16		100
M5672	M10 x 20		100
M5673	M10 x 25		100
M5674	M10 x 30		100
M5675	M10 x 35		100
M5676	M10 x 40		100
M5677	M10 x 45		100
M5678	M10 x 50		100
M5680	M10 x 60		100
M5682	M10 x 70		100
<b>M12 x 1.75 PITCH</b>			
M5710	M12 x 20mm		50
M5711	M12 x 25		50

(CONTINUED NEXT COLUMN)

LOW HEAD SOCKET CAP SCREWS			
			
<b>M12 x 1.75 PITCH</b>			
STOCK NO.	SIZE		BOX QTY.
M5712	M12 x 30		50
M5713	M12 x 35		50
M5714	M12 x 40		50
M5715	M12 x 45		50
M5716	M12 x 50		50
M5717	M12 x 60		50
M5718	M12 x 70		50
M5721	M12 x 80		50
M5723	M12 x 90		50
M5724	M12 x 100		50
M5755	M16 x 30mm		50
M5756	M16 x 35		50
M5757	M16 x 40		50
M5758	M16 x 45		50
M5759	M16 x 50		50
<b>DOWEL PINS</b>			
			
STOCK NO.	SIZE		BOX QTY.
M9415	M2 x 10		100
M944	M3 x 8		100
M9441	M3 x 10		100
M9442	M3 x 12		100
M9444	M3 x 16		100
M9446	M3 x 20		100
M9447	M3 x 25		100
M9448	M3 x 30		100
M94540	M4 x 10		100
M94541	M4 x 12		100
M94542	M4 x 14		100
M94543	M4 x 16		100
M94544	M4 x 20		100
M94545	M4 x 25		100
M94546	M4 x 30		100
M94547	M4 x 35		100
M94559	M5 x 12		100
M94560	M5 x 14		100
M94561	M5 x 16		100
M94562	M5 x 20		100
M94563	M5 x 25		100
M94564	M5 x 30		100
M94565	M5 x 35		100
M94566	M5 x 40		100
M94567	M5 x 45		100
M94568	M5 x 50		100
M94574	M6 x 16		100
M94576	M6 x 20		100
M945761	M6 x 25		100
M945762	M6 x 30		100
M945763	M6 x 35		100
M945764	M6 x 40		100
M945765	M6 x 45		100
M945766	M6 x 50		100
M945768	M6 x 60		100

(CONTINUED NEXT COLUMN)

DOWEL PINS				
				
STOCK NO.	SIZE			BOX QTY.
M94580	M8 x 16			100
M94582	M8 x 20			100
M945825	M8 x 25			100
M945827	M8 x 26			100
M94583	M8 x 30			100
M94584	M8 x 35			100
M94586	M8 x 40			100
M945865	M8 x 45			100
M94587	M8 x 50			100
M94589	M8 x 60			100
M94592	M8 x 70			100
M94593	M10 x 20			100
M94594	M10 x 25			100
M94595	M10 x 30			100
M94596	M10 x 35			100
M94597	M10 x 40			100
M94598	M10 x 45			100
M94599	M10 x 50			100
M945995	M10 x 55			50
M94600	M10 x 60			50
M94601	M10 x 70			50
M94602	M10 x 80			50
M94603	M10 x 90			50
M94605	M10 x 100			50
M946084	M12 x 20			50
M9460845	M12 x 25			50
M946085	M12 x 30			50
M9460855	M12 x 35			50
M946086	M12 x 40			50
M946087	M12 x 45			50
M946088	M12 x 50			50
M946089	M12 x 60			25
M946091	M12 x 70			25
M946093	M12 x 80			25
M946095	M12 x 90			25
M946097	M12 x 100			25
M94616	M16 x 30			25
M946165	M16 x 35			25
M94617	M16 x 40			25
M94618	M16 x 45			25
M94619	M16 x 50			25
M94621	M16 x 60			25
M94623	M16 x 70			25
M94625	M16 x 80			25
M94627	M16 x 90			25
M94629	M16 x 100			25
M94631	M16 x 110			25
M94633	M16 x 120			20
M94640	M20 x 50			25
M94642	M20 x 60			25
M94644	M20 x 70			25
M94646	M20 x 80			25
M94648	M20 x 90			25
M94650	M20 x 100			25
M94652	M20 x 110			10
M94654	M20 x 120			10
M94656	M20 x 130			10
M94658	M20 x 140			10

**METRIC SET SCREWS**

**SOCKET SET SCREWS  
CUP POINTS**



**M2 x 0.4 PITCH**

STOCK NO.	SIZE	BOX QTY.
M614	M2 x 2mm	100
M6141	M2 x 2.5	100
M6142	M2 x 3	100
M6143	M2 x 4	100
M6144	M2 x 5	100
M6145	M2 x 6	100
M6146	M2 x 8	100
M6147	M2 x 10	100
M6148	M2 x 12	100

**M2.5 x 0.45 PITCH**

M615	M2.5 x 3mm	100
M6150	M2.5 x 4	100
M6151	M2.5 x 5	100
M6152	M2.5 x 6	100
M6153	M2.5 x 8	100
M6154	M2.5 x 10	100
M6155	M2.5 x 12	100

**M3 x 0.5 PITCH**

M6159	M3 x 4mm	100
M616	M3 x 5	100
M6161	M3 x 6	100
M6162	M3 x 8	100
M6163	M3 x 10	100
M617	M3 x 12	100
M6171	M3 x 14	100
M6172	M3 x 16	100
M6173	M3 x 20	100
M6174	M3 x 25	100
M6175	M3 x 30	100

**M4 x 0.7 PITCH**

M618	M4 x 4mm	100
M6180	M4 x 5	100
M6181	M4 x 6	100
M6182	M4 x 8	100
M6183	M4 x 10	100
M6184	M4 x 12	100
M6187	M4 x 16	100
M6188	M4 x 20	100
M6189	M4 x 25	100
M619	M4 x 30	100
M6191	M4 x 35	100
M6192	M4 x 40	100

**M5 x 0.8 PITCH**

M6193	M5 x 4mm	100
M6194	M5 x 5	100
M61945	M5 x 6	100
M6195	M5 x 8	100
M6196	M5 x 10	100
M6197	M5 x 12	100
M6198	M5 x 14	100
M621	M5 x 16	100
M6212	M5 x 20	100
M6213	M5 x 25	100
M6214	M5 x 30	100
M6215	M5 x 35	100
M6216	M5 x 40	100

(CONTINUED NEXT COLUMN)

**SOCKET SET SCREWS  
CUP POINTS**



**M6 x 1.0 PITCH**

STOCK NO.	SIZE	BOX QTY.
M622	M6 x 5mm	100
M623	M6 x 6	100
M624	M6 x 8	100
M625	M6 x 10	100
M6255	M6 x 12	100
M6256	M6 x 14	100
M626	M6 x 16	100
M6261	M6 x 20	100
M6262	M6 x 25	100
M6263	M6 x 30	100
M6264	M6 x 35	100
M6265	M6 x 40	100
M6266	M6 x 45	100
M6267	M6 x 50	100

**M8 x 1.25 PITCH**

M627	M8 x 6mm	100
M628	M8 x 8	100
M629	M8 x 10	100
M630	M8 x 12	100
M6305	M8 x 14	100
M631	M8 x 16	100
M6325	M8 x 20	100
M633	M8 x 25	100
M634	M8 x 30	100
M6340	M8 x 35	100
M6341	M8 x 40	100
M6342	M8 x 45	100
M6343	M8 x 50	100
M6344	M8 x 60	100

**M10 x 1.5 PITCH**

M6349	M10 x 8mm	100
M635	M10 x 10	100
M636	M10 x 12	100
M637	M10 x 14	100
M6375	M10 x 16	100
M638	M10 x 18	100
M639	M10 x 20	100
M6391	M10 x 25	100
M6392	M10 x 30	100
M6393	M10 x 35	100
M6394	M10 x 40	100
M6395	M10 x 45	50
M6396	M10 x 50	50
M63965	M10 x 55	50
M6397	M10 x 60	50
M6398	M10 x 70	50
M6399	M10 x 80	50

**M12 x 1.75 PITCH**

STOCK NO.	SIZE	BOX QTY.
M6413	M12 x 10mm	100
M6414	M12 x 12	100
M6415	M12 x 14	100
M642	M12 x 16	100
M6425	M12 x 18	100
M643	M12 x 20	100
M6431	M12 x 25	100

(CONTINUED NEXT COLUMN)

**SOCKET SET SCREWS  
CUP POINTS**



**M12 x 1.75 PITCH**

STOCK NO.	SIZE	BOX QTY.
M6432	M12 x 30	100
M6434	M12 x 35	100
M644	M12 x 40	50
M6445	M12 x 45	50
M645	M12 x 50	50
M6450	M12 x 55	50
M6451	M12 x 60	50
M64512	M12 x 70	50
M64513	M12 x 80	50
M64514	M12 x 90	50
M64515	M12 x 100	50

**M14 x 2.0 PITCH**

M64532	M14 x 12mm	50
M64533	M14 x 14	50
M64534	M14 x 16	50
M64536	M14 x 20	50
M64537	M14 x 25	50
M64538	M14 x 30	50
M64539	M14 x 35	50
M64540	M14 x 40	50
M64541	M14 x 45	50
M64542	M14 x 50	50

**M16 x 2.0 PITCH**

M6457	M16 x 16	50
M6458	M16 x 20	50
M6459	M16 x 25	50
M6460	M16 x 30	50
M6461	M16 x 35	50
M6462	M16 x 40	50
M6463	M16 x 45	50
M6464	M16 x 50	50
M6465	M16 x 55	25
M6466	M16 x 60	25
M6468	M16 x 70	25
M647	M16 x 80	25
M6472	M16 x 90	25
M6474	M16 x 100	25

**M20 x 2.5 PITCH**

M6478	M20 x 20mm	50
M6479	M20 x 25	50
M648	M20 x 30	50
M6481	M20 x 35	50
M6482	M20 x 40	50
M6483	M20 x 45	25
M6484	M20 x 50	25
M6485	M20 x 55	25
M6486	M20 x 60	25
M6487	M20 x 70	25
M6488	M20 x 80	25
M6489	M20 x 90	25
M649	M20 x 100	25

**OTHER POINT STYLES  
AVAILABLE UPON REQUEST**

### METRIC HEX NUTS

#### COARSE THREAD HEX NUTS



STOCK NO.	SIZE	BOX QTY.
M782	M2 x .4	100
M783	M3 x .5	100
M784	M4 x .7	100
M785	M5 x .8	100
M786	M6 x 1.00	100
M7865	M7 x 1.00	100
M787	M8 x 1.25	100
M788	M10 x 1.50	100
M789	M12 x 1.75	100
M790	M14 x 2.00	50
M791	M16 x 2.00	50
M792	M18 x 2.50	25
M793	M20 x 2.50	25
794	M22 x 2.50	25
M795	M24 x 3.00	25
M7955	M27 x 3.00	25
M796	M30 x 3.50	-
79605	M33 x 3.50	-
M79607	M36 x 4.00	-
796112	M39 x 4.00	-
M79613	M42 x 4.50	-
79616	M48 x 5.00	-
-	M52 x 5.00	-
79618	M56 x 5.50	-
-	M60 x 5.50	-
-	M64 x 6.00	-
-	M68 x 6.00	-
-	M72 x 6.00	-
-	M76 x 6.00	-
79627	M80 x 6.00	-

#### FINE THREAD HEX NUTS



STOCK NO.	SIZE	BOX QTY.
-	M6 x .75	100
M7875	M8 x 1.0	100
M7884	M10 x 1.00	100
M7885	M10 x 1.25	100
M7894	M12 x 1.00	100
M7895	M12 x 1.25	100
M7896	M12 x 1.50	100
M7897	M14 x 1.50	50
-	M16 x 1.00	25
M7915	M16 x 1.50	25
M7925	M18 x 1.50	25
-	M18 x 2.00	25
-	M20 x 1.00	25
M7927	M20 x 1.50	25
7929	M20 x 2.00	25
-	M22 x 1.50	25
-	M22 x 2.00	25
M7951	M24 x 1.50	25
-	M24 x 2.00	25
-	M27 x 1.50	10
-	M27 x 2.00	10
-	M30 x 1.50	-
-	M30 x 2.00	-
-	M33 x 1.50	-
-	M33 x 2.00	-
-	M36 x 1.50	-
-	M36 x 2.00	-
79608	M36 x 3.00	-
-	M39 x 3.00	-

(CONTINUED NEXT COLUMN)

#### FINE THREAD HEX NUTS



STOCK NO.	SIZE	BOX QTY.
-	M42 x 1.50	-
-	M42 x 2.00	-
79615	M42 x 3.00	-
-	M48 x 2.00	-
-	M48 x 3.00	-
-	M52 x 2.00	-
796165	M52 x 3.00	-
796168	M56 x 2.00	-
796169	M56 x 3.00	-
79617	M56 x 4.00	-
79625	M72 x 4.00	-

#### CLASS 10 HEX NUTS - COARSE



STOCK NO.	SIZE	BOX QTY.
M7967	M6 x 1.00	100
M7968	M8 x 1.25	100
M7969	M10 x 1.50	100
M7970	M12 x 1.75	100
M7972	M16 x 2.00	50
M7973	M20 x 2.50	25
M7975	M24 x 3.00	25
-	M30 X 3.50	-
M7978	M36 X 4.00	-

#### HEX JAM NUTS - COARSE



STOCK NO.	SIZE	BOX QTY.
799	M6 x 1.00	-
M801	M8 x 1.25	-
M802	M10 x 1.50	100
M803	M12 x 1.75	100
-	M14 x 2.00	50
M804	M16 x 2.00	50
M805	M20 x 2.50	25
M807	M24 x 3.00	25
M808	M30 x 3.50	-

#### HEX JAM NUTS - FINE



STOCK NO.	SIZE	BOX QTY.
80916	M8 x 1.00	-
80917	M10 x 1.25	-
809175	M10 x 1.00	-
80918	M12 x 1.50	-
809185	M12 x 1.25	-
809186	M12 x 1.00	-
M80919	M14 x 1.50	-
M80920	M16 x 1.50	-
809205	M16 x 1.00	-
80921	M20 x 2.00	-
809215	M20 x 1.50	-
809217	M20 x 1.00	-
80922	M24 x 2.00	-
809225	M24 x 1.50	-
80924	M30 x 1.50	-
80925	M36 x 3.00	-

#### CONE LOCK NUTS



STOCK NO.	SIZE	BOX QTY.
M7788	M4 x .07	100
M7790	M6 x 1.00	100
M7791	M8 x 1.25	100
M7792	M10 x 1.50	100
M7793	M12 x 1.75	100
M7794	M14 x 2.00	50
M7795	M16 x 2.00	50
M7797	M20 x 2.50	25
M7799	M24 x 3.00	25

#### NYLON INSERT LOCK NUTS - COARSE



STOCK NO.	SIZE	BOX QTY.
M765	M3 x .5	100
M766	M4 x .7	100
M767	M5 x .8	100
M768	M6 x 1.00	100
M7685	M7 x 1.00	100
M769	M8 x 1.25	100
M770	M10 x 1.50	100
M771	M12 x 1.75	100
M772	M14 x 2.00	50
M773	M16 x 2.00	25
M775	M20 x 2.50	25
M7752	M24 x 3.00	25
-	M30 x 3.50	-
7756	M36 x 4.00	-

#### NYLON INSERT LOCK NUTS - COARSE CLASS 10



STOCK NO.	SIZE	BOX QTY.
M777722	M4 x .7	100
M777724	M6 x 1.00	100
M777726	M8 x 1.25	100
M777728	M10 x 1.50	100
M777730	M12 x 1.75	100
M777732	M14 x 2.00	50
M777734	M16 x 2.00	50
M777736	M18 x 2.50	50
M777738	M20 x 2.50	25
M777742	M24 x 3.00	25

#### NYLON INSERT LOCK NUTS - FINE



STOCK NO.	SIZE	BOX QTY.
M7771	M8 x 1.00	25
7772	M10 x 1.00	-
M7773	M10 x 1.25	25
7774	M12 x 1.25	-
M7775	M12 x 1.50	25
7776	M14 x 1.25	-
M7777	M14 x 1.50	25
M777714	M24 x 2.00	-

**METRIC FLAT WASHERS, LOCK WASHERS**

**FLAT WASHERS**

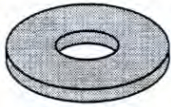

STOCK NO.	SIZE	BOX QTY.
M705	M2.5	100
M706	M3	100
M709	M3.5	100
M710	M4	100
M712	M5	100
M713	M6	100
M714	M7	100
M715	M8	100
M716	M10	100
M717	M12	100
M718	M14	100
M719	M16	100
M720	M18	100
M721	M20	100
722	M22	-
M723	M24	50
M729	M30	25
72912	M33	25
M7293	M36	25
7296	M39	25
-	M42	-
72966	M48	-
7297	M56	-

**LOCK WASHERS**



STOCK NO.	SIZE	BOX QTY.
M734	M3	100
M735	M4	100
M736	M5	100
M737	M6	100
M738	M7	100
M739	M8	100
M740	M10	100
M741	M12	100
M742	M14	100
M743	M16	100
M744	M18	100
M745	M20	100
746	M22	-
M747	M24	50
M748	M30	-
74812	M33	-
M7482	M36	-
74832	M39	-
M7484	M42	-
7485	M48	-
7487	M56	-

**EXTERNAL TOOTH LOCK WASHERS**



STOCK NO.	SIZE	BOX QTY.
M750	M5	100
M751	M6	100
M752	M8	100
M753	M10	100
-	M12	-

**INTERNAL TOOTH LOCK WASHER**



STOCK NO.	SIZE	BOX QTY.
-	M5	-
M758	M6	100
M759	M7	100
M760	M8	100
-	M10	-
-	M12	-

**HIGH COLLAR LOCK WASHERS**



FOR SOCKET CAP SCREW APPLICATIONS

STOCK NO.	SIZE	BOX QTY.
M602	M5	100
M603	M6	100
M604	M8	100
M605	M10	100
M606	M12	100
M607	M14	100
M608	M16	100
M609	M18	100
M610	M20	-
M611	M22	-
M612	M24	-
M61203	M27	-

**CALL IN YOUR  
ORDER FOR  
PROMPT,  
COURTEOUS  
ASSISTANCE**

Q: WHAT'S THE DIFFERENCE BETWEEN IGNORANCE AND APATHY?

A: I DON'T KNOW AND I DON'T CARE.

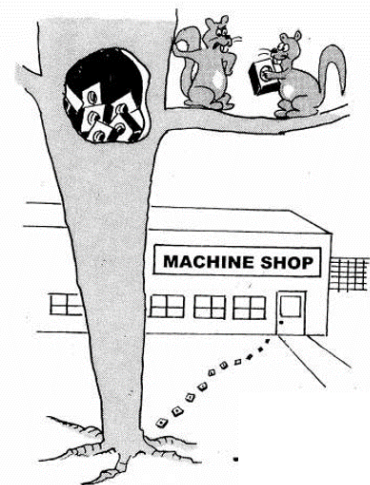

"YES, RALPH, THEY ARE NUTS, BUT...."

## METRIC MACHINE SCREWS

### SLOTTED CHEESE HEAD MACHINE SCREWS



STOCK NO.	SIZE	BOX QTY.
-	M3 x 6mm	-
-	M3 x 8	-
-	M3 x 10	-
816	M3 x 12	100
-	M3 x 14	-
<b>M818</b>	M3 x 16	100
-	M3 x 18	-
820	M3 x 20	100
825	M4 x 6mm	100
<b>M826</b>	M4 x 8	100
<b>M827</b>	M4 x 10	100
8272	M4 x 12	100
-	M4 x 14	-
828	M4 x 16	100
-	M4 x 18	-
<b>M8285</b>	M4 x 20	100
-	M4 x 25	-
<b>M830</b>	M4 x 30	100
8301	M4 x 35	100
-	M4 x 40	-
-	M4 x 45	-
<b>M8303</b>	M4 x 50	100
<b>M832</b>	M5 x 6mm	100
<b>M834</b>	M5 x 10	100
83402	M5 x 16	-
83404	M5 x 20	-
83405	M5 x 25	-
83406	M5 x 30	-
-	M5 x 35	-
-	M5 x 40	-
-	M5 x 45	-
-	M5 x 50	-
<b>M83501</b>	M6 x 10mm	100
-	M6 x 12	-
83503	M6 x 14	100
83505	M6 x 16	100
83506	M6 x 20	100
83507	M6 x 25	100
83510	M6 x 30	100
83511	M6 x 35	100
-	M6 x 40	-
-	M6 x 45	-
-	M6 x 50	-
83526	M6 x 60	100
836	M8 x 10mm	100
83601	M8 x 12	100
83603	M8 x 16	100
83606	M8 x 20	100
83607	M8 x 25	100
83608	M8 x 30	100
-	M8 x 35	-
-	M8 x 40	-
-	M8 x 45	-
83612	M8 x 50	100
-	M8 x 55	-
83614	M8 x 60	100

ADDITIONAL SIZES AND ITEMS  
AVAILABLE UPON REQUEST

### SLOTTED PAN HEAD MACHINE SCREWS

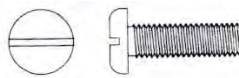

STOCK NO.	SIZE	BOX QTY.
-	M3 x 6mm	-
-	M3 x 8	-
871	M3 x 10	100
-	M3 x 12	-
872	M3 x 16	100
873	M3 x 18	100
-	M3 x 20	-
-	M3 x 25	-
<b>M875</b>	M3 x 30	100
880	M4 x 6mm	100
881	M4 x 8	100
882	M4 x 10	100
8821	M4 x 12	100
-	M4 x 14	-
883	M4 x 16	-
884	M4 x 20	100
<b>M885</b>	M4 x 25	100
-	M4 x 30	-
-	M4 x 35	-
-	M4 x 40	-
-	M4 x 45	-
-	M4 x 50	-
<b>M886</b>	M5 x 6mm	100
<b>M8869</b>	M5 x 8	100
<b>M887</b>	M5 x 10	100
<b>M8871</b>	M5 x 12	100
<b>M888</b>	M5 x 16	100
8885	M5 x 20	100
8886	M5 x 25	100
8888	M5 x 30	100
<b>M890</b>	M5 x 35	100
-	M5 x 40	-
-	M5 x 45	-
-	M5 x 50	-
891	M6 x 6mm	100
8915	M6 x 8	100
892	M6 x 10	100
8920	M6 x 12	100
<b>M8921</b>	M6 x 14	100
<b>M893</b>	M6 x 16	100
8931	M6 x 18	100
8932	M6 x 20	100
8934	M6 x 25	100
<b>M8936</b>	M6 x 30	100
-	M6 x 35	-
<b>M894</b>	M6 x 40	100
-	M6 x 45	-
<b>M896</b>	M6 x 50	100
<b>M8970</b>	M8 x 10mm	100
8971	M8 x 12	100
8973	M8 x 16	100
<b>M8974</b>	M8 x 20	100
<b>M8977</b>	M8 x 25	100
<b>M8979</b>	M8 x 30	100
-	M8 x 35	-
<b>M8981</b>	M8 x 40	100
-	M8 x 45	-
-	M8 x 50	-

### SLOTTED FLAT HEAD MACHINE SCREWS



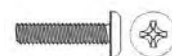

STOCK NO.	SIZE	BOX QTY.
-	M3 x 4mm	-
-	M3 x 6	-
-	M3 x 8	-
-	M3 x 10	-
-	M3 x 12	-
-	M3 x 14	-
-	M3 x 16	-
-	M3 x 18	-
-	M3 x 20	-
-	M3 x 25	-
<b>M845</b>	M3 x 30	100
8452	M4 x 6	-
-	M4 x 8	-
<b>M8455</b>	M4 x 10	100
-	M4 x 12	-
-	M4 x 14	-
<b>M8456</b>	M4 x 16	100
-	M4 x 18	-
<b>M8457</b>	M4 x 20	100
-	M4 x 25	-
-	M4 x 30	-
-	M4 x 35	-
-	M4 x 40	-
-	M4 x 45	-
<b>M846</b>	M4 x 50	100
84601	M5 x 6	-
84602	M5 x 8	-
<b>M84603</b>	M5 x 10	100
<b>M84604</b>	M5 x 12	100
846045	M5 x 14	-
<b>M84605</b>	M5 x 16	100
-	M5 x 18	-
<b>M84606</b>	M5 x 20	100
-	M5 x 25	-
-	M5 x 30	-
-	M5 x 35	-
-	M5 x 40	-
-	M5 x 45	-
-	M5 x 50	-
<b>M847</b>	M5 x 55	100
8489	M6 x 8	-
<b>M849</b>	M6 x 10	100
-	M6 x 12	-
-	M6 x 14	-
<b>M850</b>	M6 x 16	100
<b>M851</b>	M6 x 20	100
-	M6 x 25	-
-	M6 x 30	-
854	M6 x 35	-
-	M6 x 40	-
-	M6 x 45	-
-	M6 x 50	-

### PHILLIPS PAN HEAD MACHINE SCREWS



STOCK NO.	SIZE	BOX QTY.
<b>M9042</b>	M5 x 10mm	100
<b>M9043</b>	M5 x 12	100
<b>M90615</b>	M6 x 10	100
<b>M90621</b>	M6 x 12	100

**METRIC SPRING PINS**



SPRING PINS			SPRING PINS			SPRING PINS		
								
STOCK NO.	SIZE	BOX QTY.	STOCK NO.	SIZE	BOX QTY.	STOCK NO.	SIZE	BOX QTY.
95001	M1 x 4mm	-	95085	M3 x 20	-	M95173	M5 x 8mm	-
95002	M1 x 5	-	95086	M3 x 22	-	M95174	M5 x 10	-
95003	M1 x 6	-	M95087	M3 x 24	100	95175	M5 x 12	-
95004	M1 x 8	-	95088	M3 x 26	-	95176	M5 x 14	-
95005	M1 x 10	-	95089	M3 x 28	-	95177	M5 x 16	-
95006	M1 x 12	-	M95090	M3 x 30	100	95178	M5 x 18	-
95007	M1 x 14	-	95091	M3 x 32	-	M95179	M5 x 20	-
95008	M1 x 16	-	95092	M3 x 36	-	95180	M5 x 22	-
95009	M1 x 18	-	95093	M3 x 40	-	95181	M5 x 24	-
95010	M1 x 20	-				95182	M5 x 26	-
95016	M1.5 x 4mm	-	95103	M3.5 x 5mm	-	95183	M5 x 28	-
95017	M1.5 x 5	-	95104	M3.5 x 6	-	95184	M5 x 30	-
95018	M1.5 x 6	-	95105	M3.5 x 8	-	95185	M5 x 32	-
95019	M1.5 x 8	-	95106	M3.5 x 10	-	95186	M5 x 36	-
95020	M1.5 x 10	-	95107	M3.5 x 12	-	95187	M5 x 40	-
95021	M1.5 x 12	-	95108	M3.5 x 14	-	95188	M5 x 45	-
95022	M1.5 x 14	-	95109	M3.5 x 16	-	M95189	M5 x 50	100
95023	M1.5 x 16	-	95110	M3.5 x 18	-	95190	M5 x 55	-
95024	M1.5 x 18	-	M95111	M3.5 x 20	100	95191	M5 x 60	-
95025	M1.5 x 20	-	95112	M3.5 x 22	-	95192	M5 x 70	-
			95113	M3.5 x 24	-	95193	M5 x 80	-
			95114	M3.5 x 26	-			
95030	M2 x 4mm	-	95115	M3.5 x 28	-	M95203	M6 x 10mm	-
95031	M2 x 5	-	95116	M3.5 x 30	-	95204	M6 x 12	-
95032	M2 x 6	-	95117	M3.5 x 32	-	95205	M6 x 14	-
95033	M2 x 8	-	95118	M3.5 x 36	-	M95206	M6 x 16	100
95034	M2 x 10	-	95119	M3.5 x 40	-	95207	M6 x 18	-
95035	M2 x 12	-				M95208	M6 x 20	100
95036	M2 x 14	-	95129	M4 x 5mm	-	95209	M6 x 22	-
95037	M2 x 16	-	95130	M4 x 6	-	95210	M6 x 24	-
95038	M2 x 18	-	95131	M4 x 8	-	95211	M6 x 26	-
95039	M2 x 20	-	95132	M4 x 10	-	95212	M6 x 28	-
95040	M2 x 22	-	95133	M4 x 12	-	M95213	M6 x 30	-
95041	M2 x 24	-	95134	M4 x 14	-	M95214	M6 x 32	-
95042	M2 x 26	-	95135	M4 x 16	-	95215	M6 x 36	-
95043	M2 x 28	-	95136	M4 x 18	-	95216	M6 x 40	-
95044	M2 x 30	-	95137	M4 x 20	-	M95217	M6 x 45	-
			95138	M4 x 22	-	95218	M6 x 50	-
95052	M2.5 x 4mm	-	95139	M4 x 24	-	95219	M6 x 55	-
95053	M2.5 x 5	-	95140	M4 x 26	-	M95220	M6 x 60	100
95054	M2.5 x 6	-	95141	M4 x 28	-	95221	M6 x 70	-
95055	M2.5 x 8	-	95142	M4 x 30	-	95222	M6 x 75	-
95056	M2.5 x 10	-	95143	M4 x 32	-	M95223	M6 x 80	100
95057	M2.5 x 12	-	95144	M4 x 36	-	95224	M6 x 90	-
95058	M2.5 x 14	-	95145	M4 x 40	-	95225	M6 x 100	-
95059	M2.5 x 16	-	95146	M4 x 45	-			
95060	M2.5 x 18	-				M95235	M8 x 10mm	-
95061	M2.5 x 20	-	95147	M4.5 x 6mm	-	M95236	M8 x 12	100
95062	M2.5 x 22	-	95148	M4.5 x 8	-	95237	M8 x 14	-
95063	M2.5 x 24	-	95149	M4.5 x 10	-	95238	M8 x 16	-
95064	M2.5 x 26	-	95150	M4.5 x 12	-	95239	M8 x 18	-
95065	M2.5 x 28	-	95151	M4.5 x 14	-	M95240	M8 x 20	-
95066	M2.5 x 30	-	95152	M4.5 x 16	-	95241	M8 x 22	-
			95153	M4.5 x 18	-	95242	M8 x 24	-
95076	M3 x 4mm	-	95154	M4.5 x 20	-	95243	M8 x 26	-
95077	M3 x 5	-	95155	M4.5 x 22	-	95244	M8 x 28	-
95078	M3 x 6	-	95156	M4.5 x 24	-	95245	M8 x 30	-
95079	M3 x 8	-	95157	M4.5 x 26	-	95246	M8 x 32	-
95080	M3 x 10	-	95158	M4.5 x 28	-	95247	M8 x 36	-
95081	M3 x 12	-	95159	M4.5 x 30	-	95248	M8 x 40	-
95082	M3 x 14	-	95160	M4.5 x 32	-	95249	M8 x 45	-
95083	M3 x 16	-	95161	M4.5 x 36	-	95250	M8 x 50	-
95084	M3 x 18	-	95162	M4.5 x 40	-	95251	M8 x 55	-
			95163	M4.5 x 45	-	M95252	M8 x 60	100

(CONTINUED NEXT COLUMN)

(CONTINUED NEXT COLUMN)

(CONTINUED NEXT PAGE)

## METRIC SPRING PINS

SPRING PINS			SPRING PINS			SPRING PINS		
								
STOCK NO.	SIZE	BOX QTY.	STOCK NO.	SIZE	BOX QTY.	STOCK NO.	SIZE	BOX QTY.
95253	M8 x 70	-	95340	M13 x 45	-	95417	M18 x 130	-
95254	M8 x 75	-	95341	M13 x 50	-	95418	M18 x 140	-
95255	M8 x 80	-	95342	M13 x 55	-			
95256	M8 x 90	-	95343	M13 x 60	-	95423	M20 x 40	-
95257	M8 x 100	-	95344	M13 x 70	-	95424	M20 x 45	-
95258	M8 x 120	-	95345	M13 x 80	-	95425	M20 x 50	-
			95346	M13 x 90	-	95426	M20 x 55	-
95268	M10 x 12mm	-	95347	M13 x 100	-	95427	M20 x 60	-
95269	M10 x 14	-	95348	M13 x 120	-	95428	M20 x 70	-
95270	M10 x 16	-	95349	M13 x 140	-	95429	M20 x 80	-
95271	M10 x 18	-				95430	M20 x 90	-
95272	M10 x 20	-	95355	M14 x 20	-	95431	M20 x 100	-
95273	M10 x 22	-	95356	M14 x 24	-	95432	M20 x 110	-
95274	M10 x 24	-	95357	M14 x 30	-	95433	M20 x 120	-
95275	M10 x 26	-	95358	M14 x 36	-	95434	M20 x 130	-
95276	M10 x 28	-	95359	M14 x 40	-	95435	M20 x 140	-
95277	M10 x 30	-	95360	M14 x 45	-	95436	M20 x 150	-
95278	M10 x 32	-	95361	M14 x 50	-	95437	M20 x 160	-
<b>M95279</b>	M10 x 36	100	95362	M14 x 55	-			
95280	M10 x 40	-	95363	M14 x 60	-			
95281	M10 x 45	-	95364	M14 x 70	-			
95282	M10 x 50	-	95365	M14 x 80	-			
95283	M10 x 55	-	95366	M14 x 90	-			
95284	M10 x 60	-	95367	M14 x 100	-			
95285	M10 x 70	-	95368	M14 x 110	-			
95286	M10 x 80	-	95369	M14 x 120	-			
95287	M10 x 90	-	95370	M14 x 130	-			
95288	M10 x 100	-	95371	M14 x 140	-			
95289	M10 x 120	-						
			95381	M16 x 20	-			
95300	M12 x 16mm	-	95382	M16 x 24	-			
95301	M12 x 18	-	95383	M16 x 26	-			
95302	M12 x 20	-	95384	M16 x 30	-			
95303	M12 x 22	-	95385	M16 x 36	-			
95304	M12 x 24	-	95386	M16 x 40	-			
95305	M12 x 26	-	95387	M16 x 45	-			
95306	M12 x 28	-	95388	M16 x 50	-			
<b>M95307</b>	M12 x 30	100	95389	M16 x 55	-			
95308	M12 x 32	-	95390	M16 x 60	-			
95309	M12 x 36	-	95391	M16 x 70	-			
95310	M12 x 40	-	95392	M16 x 80	-			
95311	M12 x 45	-	95393	M16 x 90	-			
95312	M12 x 50	-	95394	M16 x 100	-			
95313	M12 x 55	-	95395	M16 x 110	-			
95314	M12 x 60	-	95396	M16 x 120	-			
95315	M12 x 70	-	95397	M16 x 130	-			
95316	M12 x 80	-	95398	M16 x 140	-			
95317	M12 x 90	-	95399	M16 x 150	-			
95318	M12 x 100	-	95400	M16 x 160	-			
95319	M12 x 120	-						
95320	M12 x 140	-						
			95405	M18 x 36	-			
95330	M13 x 16mm	-	95406	M18 x 40	-			
95331	M13 x 18	-	95407	M18 x 45	-			
95332	M13 x 20	-	95408	M18 x 50	-			
95333	M13 x 22	-	95409	M18 x 55	-			
95334	M13 x 24	-	95410	M18 x 60	-			
95335	M13 x 26	-	95411	M18 x 70	-			
95336	M13 x 28	-	95412	M18 x 80	-			
95337	M13 x 30	-	95413	M18 x 90	-			
95338	M13 x 36	-	95414	M18 x 100	-			
95339	M13 x 40	-	95415	M18 x 110	-			
			95416	M18 x 120	-			

(CONTINUED NEXT COLUMN)

(CONTINUED NEXT COLUMN)



**OUR  
COURTEOUS  
STAFF  
IS READY  
TO  
TAKE  
YOUR  
CALLS.  
IT IS  
OUR  
PLEASURE  
TO  
ASSIST  
YOU.**

**CALL US FOR ALL YOUR NEEDS  
855-785-TOOL**





**METRIC STAINLESS STEEL FASTENERS**

A-2 FLAT WASHERS			HEX HEAD CAP SCREWS			HEX HEAD CAP SCREWS		
								
STOCK NO.	SIZE	BOX QTY.	STOCK NO.	SIZE	BOX QTY.	STOCK NO.	SIZE	BOX QTY.
M99505	M4	100	99782	M5 x 12mm	-	M998291	M10 x 70	50
M99506	M5	100	99783	M5 x 14	-	M998293	M10 x 80	50
M99507	M6	100	99784	M5 x 16	-	M998295	M10 x 90	50
M99508	M8	100	99785	M5 x 20	-	M99830	M10 x 100	50
M99509	M10	100	M99786	M5 x 25	100	998300	M10 x 110	-
M99510	M12	100	99787	M5 x 30	-	-	M10 x 120	-
M99511	M14	100	99788	M5 x 35	-	998301	M12 x 20mm	-
M99512	M16	50	99789	M5 x 40	-	M998302	M12 x 25	50
99513	M18	50	99790	M5 x 45	-	M99831	M12 x 30	50
99514	M20	50	99791	M5 x 50	-	M99832	M12 x 35	50
99516	M24	50	M99792	M5 x 60	100	M99833	M12 x 40	50
						M99834	M12 x 45	50
			99793	M6 x 8mm	-	M99835	M12 x 50	50
			99794	M6 x 10	-	M99836	M12 x 55	50
			M99795	M6 x 12	100	M99837	M12 x 60	50
			M99797	M6 x 16	100	-	M12 x 65	-
			M99798	M6 x 20	100	M99838	M12 x 70	25
			M99799	M6 x 25	100	-	M12 x 75	-
			M99800	M6 x 30	100	M99839	M12 x 80	25
			M99801	M6 x 35	100	M998392	M12 x 90	25
			M99802	M6 x 40	100	-	M12 x 100	-
			-	M6 x 45	-	-	M12 x 110	-
			-	M6 x 50	-	-	M12 x 120	-
			-	M6 x 55	-	-		
			998025	M6 x 60	-	-	M16 x 30mm	-
			-	M6 x 65	-	99851	M16 x 35	-
			998026	M6 x 70	-	99852	M16 x 40	-
			-	M6 x 75	-	99854	M16 x 45	-
			-	M6 x 80	-	99855	M16 x 50	-
			-	M6 x 90	-	99856	M16 x 55	-
			998029	M6 x 100	-	99857	M16 x 60	-
						99858	M16 x 65	-
			99803	M8 x 10mm	-	99859	M16 x 70	-
			M998031	M8 x 12	100	99860	M16 x 75	-
			-	M8 x 14	-	99861	M16 x 80	-
			998032	M8 x 16	-	99862	M16 x 90	-
			M99804	M8 x 20	100	99863	M16 x 100	-
			M99805	M8 x 25	100	99864	M16 x 110	-
			M99806	M8 x 30	100	99865	M16 x 120	-
			M99807	M8 x 35	100	99867	M16 x 130	-
			M99808	M8 x 40	100	-	M16 x 140	-
			M99809	M8 x 45	100	99869	M16 x 150	-
			M99810	M8 x 50	100	-		
			M99811	M8 x 55	100	-	M20 x 30mm	-
			M99812	M8 x 60	100	-	M20 x 35	-
			-	M8 x 65	-	-	M20 x 40	-
			M998122	M8 x 70	100	-	M20 x 45	-
			-	M8 x 75	-	99872	M20 x 50	-
			-	M8 x 80	-	-	M20 x 55	-
			-	M8 x 90	-	-	M20 x 60	-
			-	M8 x 100	-	-	M20 x 65	-
			99815	M10 x 16mm	-	99875	M20 x 70	-
			M99820	M10 x 20	100	99876	M20 x 80	-
			M99821	M10 x 25	100	-	M20 x 90	-
			M99822	M10 x 30	100	99879	M20 x 100	-
			M99823	M10 x 35	100	-	M20 x 110	-
			M99824	M10 x 40	100	-	M20 x 120	-
			M99825	M10 x 45	100	-	M20 x 130	-
			M99826	M10 x 50	50	-	M20 x 140	-
			M99827	M10 x 55	50	-	M20 x 150	-
			M99828	M10 x 60	50	-		
			99829	M10 x 65	-			
<b>THIS SPACE RESERVED FOR FUTURE METRIC FASTENER PRODUCTS</b>			<i>(CONTINUED NEXT COLUMN)</i>			TALK IS CHEAP---EXCEPT WHEN CONGRESS DOES IT.		
						--CULLEN HIGHTOWER		

## METRIC STAINLESS STEEL FASTENERS

### SOCKET HEAD CAP SCREWS

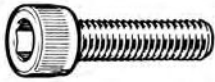

STOCK NO.	SIZE	BOX QTY.
99895	M3 x 6mm	-
<b>M998952</b>	M3 x 8	100
<b>M998954</b>	M3 x 10	100
<b>M99896</b>	M3 x 12	100
<b>M998962</b>	M3 x 14	100
998963	M3 x 16	-
<b>M99897</b>	M3 x 20	100
99898	M3 x 25	-
99900	M4 x 5mm	-
99901	M4 x 6	-
99902	M4 x 8	-
<b>M99903</b>	M4 x 10	100
<b>M99904</b>	M4 x 12	100
<b>M99905</b>	M4 x 16	100
<b>M99907</b>	M4 x 20	100
<b>M99908</b>	M4 x 25	100
<b>M99909</b>	M4 x 30	100
99910	M4 x 35	-
-	M4 x 40	-
-	M4 x 45	-
<b>M99913</b>	M4 x 50	-
<b>M99914</b>	M5 x 8mm	100
<b>M99915</b>	M5 x 10	100
<b>M99916</b>	M5 x 12	100
99918	M5 x 16	-
<b>M99920</b>	M5 x 20	100
<b>M99921</b>	M5 x 25	100
<b>M99922</b>	M5 x 30	100
<b>M999225</b>	M5 x 35	100
<b>M99923</b>	M5 x 40	100
<b>M999235</b>	M5 x 45	100
<b>M99924</b>	M5 x 50	100
-	M5 x 55	-
-	M5 x 60	-
-	M5 x 65	-
-	M5 x 70	-
-	M5 x 75	-
-	M5 x 80	-
-	M5 x 90	-
<b>M99929</b>	M5 x 100	100
<b>M99938</b>	M6 x 10mm	100
<b>M99939</b>	M6 x 12	100
<b>M99941</b>	M6 x 16	100
<b>M99943</b>	M6 x 20	100
999431	M6 x 22	-
<b>M99944</b>	M6 x 25	100
<b>M99945</b>	M6 x 30	100
<b>M99946</b>	M6 x 35	100
<b>M99947</b>	M6 x 40	100
<b>M99948</b>	M6 x 45	100
<b>M99949</b>	M6 x 50	100
<b>M99950</b>	M6 x 55	100
<b>M99951</b>	M6 x 60	100
<b>M99952</b>	M6 x 65	100
<b>M99953</b>	M6 x 70	100
<b>M99954</b>	M6 x 75	100
<b>M99955</b>	M6 x 80	50
<b>M99956</b>	M6 x 90	50
<b>M99957</b>	M6 x 100	50
<b>M99958</b>	M6 x 110	50
<b>M99959</b>	M6 x 120	50
9995902	M6 x 130	-
9995904	M6 x 140	-
999591	M6 x 150	-

(CONTINUED NEXT COLUMN)

### SOCKET HEAD CAP SCREWS

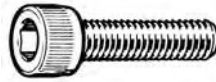

STOCK NO.	SIZE	BOX QTY.
999599	M8 x 12mm	-
<b>M99960</b>	M8 x 16	100
<b>M99961</b>	M8 x 20	100
<b>M99962</b>	M8 x 25	100
<b>M99963</b>	M8 x 30	100
<b>M99964</b>	M8 x 35	100
<b>M99965</b>	M8 x 40	100
<b>M99966</b>	M8 x 45	100
<b>M99967</b>	M8 x 50	100
<b>M99968</b>	M8 x 55	100
<b>M99969</b>	M8 x 60	100
<b>M99970</b>	M8 x 65	100
99971	M8 x 70	-
99973	M8 x 80	-
99974	M8 x 90	-
99975	M8 x 100	-
99976	M8 x 110	-
99977	M8 x 120	-
-	M8 x 130	-
-	M8 x 140	-
99980	M8 x 150	-
-	M10 x 12mm	-
-	M10 x 16	-
<b>M99981</b>	M10 x 20	100
<b>M99982</b>	M10 x 25	100
<b>M99983</b>	M10 x 30	100
<b>M99984</b>	M10 x 35	100
<b>M99985</b>	M10 x 40	100
<b>M99986</b>	M10 x 45	100
<b>M99987</b>	M10 x 50	100
99988	M10 x 55	-
<b>M99989</b>	M10 x 60	100
99990	M10 x 65	-
<b>M99991</b>	M10 x 70	100
99992	M10 x 75	-
99993	M10 x 80	-
-	M10 x 90	-
-	M10 x 100	-
-	M10 x 110	-
-	M10 x 120	-
-	M10 x 130	-
-	M10 x 140	-
-	M10 x 150	-
99994	M12 x 20mm	-
999941	M12 x 25	-
999942	M12 x 30	-
<b>M999943</b>	M12 x 35	50
<b>M999944</b>	M12 x 40	50
-	M12 x 45	-
-	M12 x 50	-
-	M12 x 55	-
-	M12 x 60	-
-	M12 x 65	-
-	M12 x 70	-
-	M12 x 75	-
-	M12 x 80	-
-	M12 x 90	-
-	M12 x 100	-
-	M12 x 110	-
-	M12 x 120	-
-	M12 x 130	-
-	M12 x 140	-
-	M12 x 150	-

(CONTINUED NEXT COLUMN)

### SOCKET HEAD CAP SCREWS



STOCK NO.	SIZE	BOX QTY.
-	M14 x 20mm	-
-	M14 x 25	-
-	M14 x 30	-
-	M14 x 35	-
-	M14 x 40	-
-	M14 x 45	-
-	M14 x 50	-
-	M14 x 55	-
-	M14 x 60	-
-	M14 x 65	-
-	M14 x 70	-
-	M14 x 75	-
-	M14 x 80	-
-	M14 x 90	-
-	M14 x 100	-
-	M16 x 25mm	-
999963	M16 x 30	-
-	M16 x 35	-
-	M16 x 40	-
-	M16 x 45	-
999965	M16 x 50	-
9999651	M16 x 55	-
-	M16 x 60	-
9999653	M16 x 65	-
999967	M16 x 70	-
-	M16 x 75	-
-	M16 x 80	-
-	M16 x 90	-
-	M16 x 100	-

WHEN THE FARMER ARRIVED AT THE OBEDIENCE SCHOOL TO PICK UP HIS NEWLY TRAINED BIRD DOG, HE ASKED THE INSTRUCTOR FOR A DEMONSTRATION. THE TWO MEN AND THE DOG WENT TO A NEARBY FIELD, WHERE THE DOG IMMEDIATELY POINTED TO A CLUMP OF BRUSH, THEN ROLLED OVER TWICE. "THERE ARE TWO BIRDS IN THERE," THE INSTRUCTOR SAID, AND SURE ENOUGH, TWO BIRDS WERE FLUSHED. A MINUTE LATER, THE DOG POINTED TO ANOTHER BUNCH OF BUSHES, AND THEN ROLLED OVER FIVE TIMES. "THERE ARE FIVE BIRDS IN THERE," THE INSTRUCTOR NOTED AND INDEED FIVE BIRDS WERE DRIVEN FROM THE BRUSH. THEN THE DOG POINTED TO A THIRD CLUMP. HE BEGAN TO WHINE AND RUN IN CIRCLES UNTIL HE FOUND A STICK, WHICH HE SHOOK MIGHTILY AND DROPPED AT THE MEN'S FEET. "AND IN THAT CLUMP OF BRUSH THERE," THE PROUD INSTRUCTOR CONCLUDED, "THERE ARE MORE BIRDS THAN YOU CAN SHAKE A STICK AT!"

METRIC STAINLESS STEEL FASTENERS

FLAT HEAD SOCKET CAP SCREWS

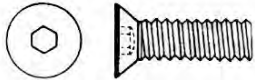

M2 x 0.4 PITCH

STOCK NO.	SIZE	BOX QTY.
M9988771	M2 x 4mm	100
M9988772	M2 x 5	100
M9988773	M2 x 6	100
M9988774	M2 x 8	100

M3 x 0.5 PITCH

M9988804	M3 x 5mm	100
M9988805	M3 x 6	100
M9988806	M3 x 8	100
M9988807	M3 x 10	100
M9988808	M3 x 12	100
M9988809	M3 x 14	100
M9988810	M3 x 16	100
M9988812	M3 x 20	100

M4 x 0.7 PITCH

M9988819	M4 x 6mm	100
M9988820	M4 x 8	100
M9988821	M4 x 10	100
M9988822	M4 x 12	100
M9988823	M4 x 14	100
M9988824	M4 x 16	100
M9988826	M4 x 20	100
M9988827	M4 x 25	100
M9988828	M4 x 30	100
M9988829	M4 x 35	100
M9988830	M4 x 40	100

M5 x 0.8 PITCH

M9988839	M5 x 8mm	100
M9988840	M5 x 10	100
M9988841	M5 x 12	100
M9988842	M5 x 14	100
M9988843	M5 x 16	100
M9988845	M5 x 20	100
M9988846	M5 x 25	100
M9988847	M5 x 30	100
M9988848	M5 x 35	100

M6 x 1.0 PITCH

M9988863	M6 x 10mm	100
M9988864	M6 x 12	100
M9988866	M6 x 16	100
M9988868	M6 x 20	100
M9988869	M6 x 25	100
M9988870	M6 x 30	100
M9988871	M6 x 35	100
M9988872	M6 x 40	100
M9988873	M6 x 45	100
M9988874	M6 x 50	100

(CONTINUED NEXT COLUMN)

FLAT HEAD SOCKET CAP SCREWS

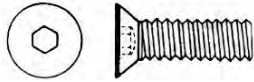

M8 x 1.25 PITCH

STOCK NO.	SIZE	BOX QTY.
M9988886	M8 x 12mm	100
M9988888	M8 x 16	100
M9988890	M8 x 20	100
M9988891	M8 x 25	100
M9988892	M8 x 30	100
M9988893	M8 x 35	100
M9988894	M8 x 40	100
M9988895	M8 x 45	100
M9988896	M8 x 50	100
M9988898	M8 x 60	50

M10 x 1.5 PITCH

M9988916	M10 x 20mm	100
M9988917	M10 x 25	100
M9988918	M10 x 30	100
M9988919	M10 x 35	100
M9988920	M10 x 40	100
M9988921	M10 x 45	100
M9988922	M10 x 50	100

M12 x 1.75 PITCH

M9988938	M12 x 20mm	100
M9988939	M12 x 25	100
M9988940	M12 x 30	100
M9988941	M12 x 35	100
M9988942	M12 x 40	100
M9988943	M12 x 45	100
M9988944	M12 x 50	100
M9988945	M12 x 55	50
M9988946	M12 x 60	50
M9988948	M12 x 70	50

M16 x 2.0 PITCH

M9988986	M16 x 35mm	50
M9988987	M16 x 40	50
M9988988	M16 x 45	50
M9988989	M16 x 50	50
M9988990	M16 x 55	50
M9988991	M16 x 60	50
M9988993	M16 x 70	25
M9988995	M16 x 80	25
M9988997	M16 x 90	25
M9988999	M16 x 100	25



"I think you want Phillips. Two doors down on the left."

BUTTON HEAD SOCKET CAP SCREWS

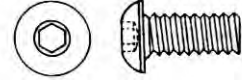

M2 x 0.4 PITCH

STOCK NO.	SIZE	BOX QTY.
M9988597	M2 x 3mm	100
M9988598	M2 x 4	100
M9988599	M2 x 5	100
M9988600	M2 x 6	100
M9988601	M2 x 8	100
M9988602	M2 x 10	100
M9988603	M2 x 12	100
M9988604	M2 x 16	100
M9988606	M2 x 20	100

M3 x 0.5 PITCH

-	M3 x 4mm	100
M9988629	M3 x 5	100
M9988630	M3 x 6	100
M9988631	M3 x 8	100
M9988632	M3 x 10	100
M9988633	M3 x 12	100
M9988634	M3 x 14	100
M9988649	M3 x 16	100
M9988650	M3 x 20	100
M9988651	M3 x 25	100
M9988652	M3 x 30	100
M9988653	M3 x 35	100
M9988654	M3 x 40	100

M4 x 0.7 PITCH

-	M4 x 5mm	100
M9988644	M4 x 6	100
M9988645	M4 x 8	100
M9988646	M4 x 10	100
M9988647	M4 x 12	100
M9988648	M4 x 14	100
M9988649	M4 x 16	100
M9988650	M4 x 20	100
M9988651	M4 x 25	100
M9988652	M4 x 30	100
M9988653	M4 x 35	100
M9988654	M4 x 40	100

M5 x 0.8 PITCH

M9988663	M5 x 6mm	100
M9988664	M5 x 8	100
M9988665	M5 x 10	100
M9988666	M5 x 12	100
M9988667	M5 x 14	100
M9988668	M5 x 16	100
M9988670	M5 x 20	100
M9988671	M5 x 25	100
M9988672	M5 x 30	100
M9988673	M5 x 35	100
M9988674	M5 x 40	100
M9988675	M5 x 45	100
M9988676	M5 x 50	100

(CONTINUED NEXT PAGE)

**METRIC STAINLESS STEEL FASTENERS**

**BUTTON HEAD SOCKET CAP SCREWS**

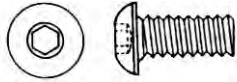

M6 x 1.0 PITCH

STOCK NO.	SIZE	BOX QTY.
M9988685	M6 x 8mm	100
M9988686	M6 x 10	100
M9988687	M6 x 12	100
M9988688	M6 x 14	100
M9988689	M6 x 16	100
M9988691	M6 x 20	100
M9988692	M6 x 25	100
M9988693	M6 x 30	100
M9988694	M6 x 35	100
M9988695	M6 x 40	100
M9988696	M6 x 45	100
M9988697	M6 x 50	100

**M8 x 1.25 PITCH**

M9988705	M8 x 10mm	100
M9988706	M8 x 12	100
M9988707	M8 x 14	100
M9988708	M8 x 16	100
M9988710	M8 x 20	100
M9988711	M8 x 25	100
M9988712	M8 x 30	100
M9988713	M8 x 35	100
M9988714	M8 x 40	100
M9988715	M8 x 45	100
M9988716	M8 x 50	100
M9988718	M8 x 60	50
M9988720	M8 x 70	50
M9988722	M8 x 80	50

**M10 x 1.5 PITCH**

M9988729	M10 x 20mm	100
M9988730	M10 x 25	100
M9988731	M10 x 30	100
M9988732	M10 x 35	100
M9988733	M10 x 40	100
M9988734	M10 x 45	100
M9988735	M10 x 50	100
M9988737	M10 x 60	100
M9988738	M10 x 70	100
M9988739	M10 x 80	100

A GUY WALKS INTO A BAR AND ORDERS A BEER. "LISTEN," HE SAYS TO THE BARTENDER. "IF I SHOW YOU THE MOST AMAZING THING YOU'VE EVER SEEN, IS MY BEER ON THE HOUSE?" "WE'LL SEE," SAYS THE BARTENDER. SO THE GUY PULLS A HAMSTER AND A TINY PIANO OUT OF A BAG, PUTS THEM ON THE BAR, AND THE HAMSTER BEGINS TO PLAY. "IMPRESSIVE," SAYS THE BARTENDER, "BUT I'LL HAVE TO SEE MORE." "HOLD ON," SAYS THE MAN. HE THEN PULLS OUT A BULLFROG, AND IT SINGS "OLD MAN RIVER." A PATRON JUMPS UP FROM HIS TABLE AND SHOUTS, "THAT'S ABSOLUTELY INCREDIBLE! I'LL GIVE YOU \$100 RIGHT NOW FOR THE FROG." "SOLD," SAYS THE GUY. THE OTHER PATRON TAKES THE BULLFROG AND LEAVES. "IT'S NONE OF MY BUSINESS," SAYS THE BARTENDER, "BUT YOU JUST GAVE AWAY A FORTUNE." "NOT REALLY," SAYS THE GUY. "THE HAMSTER IS ALSO A VENTRILOQUIST."

**SOCKET SET SCREWS CUP POINTS**



M2 x 0.4 PITCH

STOCK NO.	SIZE	BOX QTY.
-	M2 x 3	100
-	M2 x 4	100
-	M2 x 5	100
-	M2 x 6	100
-	M2 x 8	100
-	M2 x 10	100

**M3 x 0.5 PITCH**

999970	M3 x 4mm	100
-	M3 x 5	100
-	M3 x 6	100
-	M3 x 8	100
-	M3 x 10	100
-	M3 x 12	100

**M4 x 0.7 PITCH**

-	M4 x 4mm	100
999975	M4 x 5	100
999976	M4 x 6	100
999978	M4 x 8	100
999979	M4 x 10	100
-	M4 x 12	100

**M5 x 0.8 PITCH**

9999799	M5 x 5mm	100
999980	M5 x 6	100
-	M5 x 8	100
-	M5 x 10	100
-	M5 x 12	100

**M6 x 1.0 PITCH**

9999819	M6 x 6mm	100
-	M6 x 8	100
999982	M6 x 10	100
999983	M6 x 12	100
999984	M6 x 16	100
-	M6 x 20	100

**M8 x 1.25 PITCH**

-	M8 x 8mm	100
-	M8 x 10	100
99999	M8 x 12	100
-	M8 x 16	100
-	M8 x 20	100
-	M8 x 25	100

**M10 x 1.5 PITCH**

-	M10 x 10mm	100
-	M10 x 12	100
-	M10 x 16	100
-	M10 x 20	100
-	M10 x 25	100

**M12 x 1.75 PITCH**

STOCK NO.	SIZE	BOX QTY.
-	M12 x 10mm	100
-	M12 x 12	100
-	M12 x 16	100
-	M12 x 20	100
-	M12 x 25	100
-	M12 x 30	100
-	M12 x 35	100

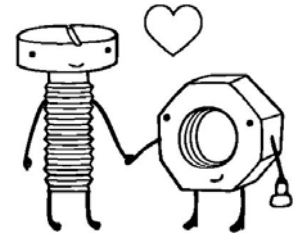

**CALL US FOR ALL YOUR NEEDS  
855-785-TOOL**

**METRIC STAINLESS STEEL FASTENERS**

**PHILLIPS PAN HEAD  
MACHINE SCREW**

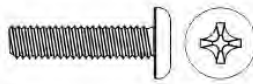

STOCK NO.	SIZE	BOX QTY.
M99001	M2 x 4mm	-
M99002	M2 x 5	-
M99003	M2 x 6	-
M99004	M2 x 8	-
M99005	M2 x 10	-
M99006	M2 x 12	-
M99008	M2 x 16	-
M99010	M2 x 20	-
M99028	M3 x 4mm	-
M99029	M3 x 5	-
M99030	M3 x 6	-
M99031	M3 x 8	-
M99032	M3 x 10	-
M99033	M3 x 12	-
M99035	M3 x 16	-
M99037	M3 x 20	-
M99038	M3 x 25	-
M99039	M3 x 30	-
M99040	M3 x 35	-
M99041	M3 x 40	-
M99061	M4 x 6mm	-
M99062	M4 x 8	-
M99063	M4 x 10	-
M99064	M4 x 12	-
M99065	M4 x 14	-
M99066	M4 x 16	-
M99067	M4 x 18	-
M99068	M4 x 20	-
M99070	M4 x 25	-
M99071	M4 x 30	-
M99072	M4 x 35	-
M99073	M4 x 40	-
M99074	M4 x 45	-
M99075	M4 x 50	-
M99082	M5 x 8mm	-
M99083	M5 x 10	-
M99084	M5 x 12	-
M99085	M5 x 14	-
M99086	M5 x 16	-
M99088	M5 x 20	-
M99090	M5 x 25	-
M99091	M5 x 30	-
M99092	M5 x 35	-
M99093	M5 x 40	-
M99094	M5 x 45	-
M99095	M5 x 50	-
M99100	M6 x 8mm	-
M99101	M6 x 10	-
M99102	M6 x 12	-
M99103	M6 x 14	-
M99104	M6 x 16	-
M99105	M6 x 18	-
M99106	M6 x 20	-
M99107	M6 x 25	-
M99108	M6 x 30	-
M99109	M6 x 35	-
M99110	M6 x 40	-
M99111	M6 x 45	-
M99112	M6 x 50	-
M99113	M6 x 60	-
M99114	M6 x 70	-
M99115	M6 x 80	-
M99116	M6 x 90	-
M99117	M6 x 100	-

**PHILLIPS FLAT HEAD  
MACHINE SCREW**

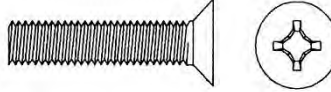

STOCK NO.	SIZE	BOX QTY.
M99150	M2 x 4mm	-
M99151	M2 x 5	-
M99152	M2 x 6	-
M99153	M2 x 8	-
M99154	M2 x 10	-
M99155	M2 x 12	-
M99157	M2 x 16	-
M99169	M3 x 4mm	-
M99170	M3 x 5	-
M99171	M3 x 6	-
M99172	M3 x 8	-
M99173	M3 x 10	-
M99174	M3 x 12	-
M99175	M3 x 14	-
M99176	M3 x 16	-
M99177	M3 x 18	-
M99178	M3 x 20	-
M99179	M3 x 25	-
M99180	M3 x 30	-
M99181	M3 x 35	-
M99182	M3 x 40	-
M99186	M4 x 5mm	-
M99187	M4 x 6	-
M99188	M4 x 8	-
M99189	M4 x 10	-
M99190	M4 x 12	-
M99191	M4 x 14	-
M99192	M4 x 16	-
M99193	M4 x 18	-
M99194	M4 x 20	-
M99195	M4 x 25	-
M99196	M4 x 30	-
M99197	M4 x 35	-
M99198	M4 x 40	-
M99199	M4 x 45	-
M99200	M4 x 50	-
M99203	M5 x 8mm	-
M99204	M5 x 10	-
M99205	M5 x 12	-
M99206	M5 x 14	-
M99207	M5 x 16	-
M99208	M5 x 18	-
M99209	M5 x 20	-
M99210	M5 x 25	-
M99211	M5 x 30	-
M99212	M5 x 35	-
M99213	M5 x 40	-
M99214	M5 x 45	-
M99215	M5 x 50	-
M99219	M6 x 10mm	-
M99220	M6 x 12	-
M99221	M6 x 14	-
M99222	M6 x 16	-
M99223	M6 x 18	-
M99224	M6 x 20	-
M99225	M6 x 25	-
M99226	M6 x 30	-
M99227	M6 x 35	-
M99228	M6 x 40	-
M99229	M6 x 45	-
M99230	M6 x 50	-
M99231	M6 x 55	-
M99232	M6 x 60	-
M99233	M6 x 70	-
M99234	M6 x 80	-



## ALLTHREAD ROD

### 3 FT. LOW CARBON - ZINC PLATED USS COARSE THREAD

STOCK NO.	SIZE
K2995	4-40
K300	6-32
K302	8-32
K304	10-24
K305	12-24
K306	1/4-20
K307	5/16-18
K308	3/8-16
K309	7/16-14
K310	1/2-13
K311	9/16-12
K312	5/8-11
K313	3/4-10
K314	7/8-9
K315	1"-8
K316*	1-1/8-7
K317*	1-1/4-7
K319*	1-1/2-6
K320*	1-3/4-5
K321*	2"-4-1/2

\*PLAIN FINISH

### 3 FT. LOW CARBON - ZINC PLATED SAE FINE THREAD

STOCK NO.	SIZE
K303	10-32
K325	1/4-28
K326	5/16-24
K327	3/8-24
K328	7/16-20
K329	1/2-20
K331	5/8-18
K332	3/4-16
K333	7/8-14
K334	1"-14
K335	1-1/4-12

### 3 FT. LOW CARBON - PLAIN FINISH LEFT HAND THREAD

STOCK NO.	SIZE
K130	1/4-20
K132	5/16-18
K134	3/8-16
K138	1/2-13
K142	5/8-11
K143	3/4-10
K144	7/8-9
K145	1"-8

ADDITIONAL SIZES IN VARIOUS LENGTHS  
AVAILABLE UPON REQUEST

### 3 FT. NYLON ALLTHREAD NATURAL COLOR - CORROSION RESISTANT

STOCK NO.	SIZE
PMC75	1/4-20
PMC76	5/16-18
PMC77	3/8-16
PMC78	1/2-13

### 6 FT. LOW CARBON - ZINC PLATED

STOCK NO.	SIZE
K345	1/4-20
K347	3/8-16
K362	3/8-24
K349	1/2-13
K351	5/8-11
K352	3/4-10

### 6 FT. LOW CARBON - PLAIN FINISH

STOCK NO.	SIZE
K101	1/4-20
K103	5/16-18
K105	3/8-16
K109	1/2-13
K454	1/2-20
K113	5/8-11
K115	3/4-10
K117	7/8-9
K119	1"-8
K121	1-1/8-7
K123	1-1/4-7
K125	1-1/2-6
K127	2"-4-1/2

### 12 FT. LOW CARBON - PLAIN FINISH

STOCK NO.	SIZE
K1503	3/8-16
K1505	1/2-13

### 12 FT. LOW CARBON - ZINC PLATED

STOCK NO.	SIZE
K3475	3/8-16
K3495	1/2-13

### 3 FT. BRASS ALLTHREAD

STOCK NO.	SIZE
BF637	6-32
BF638	8-32
BF639	10-24
BF640	10-32
BF641	1/4-20
BF642	5/16-18
BF643	3/8-16
BF644	1/2-13
BF645	5/8-11
BF646	3/4-10
BF647	7/8-9
BF648	1"-8

### 3 FT. STAINLESS STEEL ALLTHREAD

STOCK NO.	SIZE
S715	6-32
S716	8-32
S717	10-32
S718	10-24
S720	1/4-20
S7301	1/4-28
S721	5/16-18
S7302	5/16-24
S722	3/8-16
S724	1/2-13
S726	5/8-11
S727	3/4-10
S728	7/8-9
S729	1"-8

### 6 FT. STAINLESS STEEL ALLTHREAD

STOCK NO.	SIZE
S732	1/4-20
S733	5/16-18
S734	3/8-16
S735	1/2-13
S7434	1/2-20
S736	5/8-11
S737	3/4-10

### 29 DEGREE ACME ALLTHREAD 3 FT. LOW CARBON - PLAIN FINISH

STOCK NO.	SIZE
K163	3/4-6
K165	1"-5
K167	1-1/4-5
K169	1-1/2-4



**ALLTHREAD ROD**

**B-7 ALLOY ALLTHREAD  
3 FT. HEAT-TREATED - PLAIN FINISH  
USS COARSE THREAD**

STOCK NO.	SIZE
K201	1/4-20
K2015	5/16-18
K202	3/8-16
K203	7/16-14
K204	1/2-13
K206	5/8-11
K207	3/4-10
K208	7/8-9
K209	1"-8
K210	1-1/8-7
K211	1-1/4-7
K212	1-3/8-6
K213	1-1/2-6
K215	1-3/4-5
K216	2"-4-1/2

**B-7 ALLOY ALLTHREAD  
3 FT. HEAT-TREATED - PLAIN FINISH  
SAE FINE THREAD**

STOCK NO.	SIZE
K220	1/4-28
K221	5/16-24
K222	3/8-24
K223	7/16-20
K224	1/2-20
K2245	9/16-18
K225	5/8-18
K226	3/4-16
K227	7/8-14
K228	1"-14
K229	1-1/8-12
K230	1-1/4-12
K231	1-3/8-12
K232	1-1/2-12
K233	1-3/4-12
K244	2"-8
K234	2"-12
K2345	2"-1/4-12

**B-7 ALLOY ALLTHREAD  
6 FT. HEAT TREATED - PLAIN FINISH  
USS COARSE THREAD**

STOCK NO.	SIZE
K272	3/8-16
K274	1/2-13
K275	5/8-11
K276	3/4-10
K277	7/8-9
K278	1"-8
K279	1-1/8-7
K280	1-1/4-7
K282	1-1/2-6

**METRIC ALLTHREAD  
1 METER - PLAIN FINISH**

STOCK NO.	SIZE
M927	M3 x 0.50
M928	M4 x 0.70
M929	M5 x 0.80
M930	M6 x 1.00
M931	M8 x 1.25
M932	M10 x 1.50
M933	M12 x 1.75
M934	M14 x 2.00
M935	M16 x 2.00
M937	M20 x 2.50
9371	M22 x 2.50
M9372	M24 x 3.00
M9374	M30 x 3.50

**B-7 METRIC ALLTHREAD  
1 METER - PLAIN FINISH**

STOCK NO.	SIZE
93965	M6 x 1.00
M93966	M8 x 1.25
M93968	M10 x 1.50
M93970	M12 x 1.75
M93974	M14 x 2.00
M93976	M16 x 2.00
M93980	M20 x 2.50
M93983	M24 x 3.00
M93985	M30 x 3.50

**8 THREAD**

**B-7 ALLOY ALLTHREAD  
6 FT. HEAT-TREATED - PLAIN FINISH**

STOCK NO.	SIZE
K2391	1-1/8-8
K2402	1-1/4-8
2404	1-1/2-8

**GRADE 8 ALLOY ALLTHREAD  
(A354 BD)**

**3 FT. HEAT-TREATED - PLAIN FINISH  
USS COARSE THREAD**

STOCK NO.	SIZE
K247513	3/8-16
K247514	1/2-13
K247515	5/8-11
K247516	3/4-10
K247517	7/8-9
K247518	1"-8

ADDITIONAL ALLTHREAD  
AVAILABLE UPON REQUEST

**CALL IN YOUR ORDER FOR PROMPT,  
COURTEOUS ASSISTANCE**

### DRILL ROD AND FLAT GROUND STOCK

#### (W-1) WATER HARDENING DRILL ROD



THE MOST POPULAR, VERSATILE AND LEAST EXPENSIVE GRADE OF DRILL ROD. ITS HIGH CARBON CONTENT ALLOWS IT TO BE USED WITHOUT HEAT TREATMENT FOR MANY MAINTENANCE APPLICATIONS. 36" LENGTH.

STOCK NO.	SIZE	STOCK NO.	SIZE
108	1/16	DR19	5/8
1085	5/64	192	41/64
109	3/32	194	21/32
1095	7/64	196	43/64
DR11	1/8	DR20	11/16
112	9/64	202	45/64
DR115	5/32	204	23/32
116	11/64	206	47/64
DR12	3/16	DR21	3/4
121	13/64	212	49/64
125	7/32	214	25/32
126	17/64	216	51/64
DR13	1/4	DR22	13/16
132	17/64	224	53/64
134	9/32	226	27/32
136	19/64	228	55/64
DR14	5/16	DR23	7/8
142	21/64	232	57/64
145	11/32	234	29/32
146	23/64	236	59/64
DR15	3/8	DR24	15/16
152	25/64	242	61/64
154	13/32	244	31/32
156	27/64	246	63/64
DR16	7/16	DR25	1"
162	29/64	DR255	1-1/16
164	15/32	DR26	1-1/8
166	31/64	DR27	1-3/16
DR17	1/2	DR28	1-1/4
172	33/64	29	1-5/16
174	17/32	DR30	1-3/8
176	35/64	31	1-7/16
DR18	9/16	DR32	1-1/2
182	37/64		
184	19/32		
186	39/64		

#### (W-1) WATER HARDENING DRILL ROD



6 FT. LENGTH

STOCK NO.	SIZE
DR770	3/8
DR778	1/2
DR786	5/8
DR794	3/4
DR810	1"

CALL FOR COMPLETE SPECIFICATIONS AND PRICES

#### (O-1) OIL HARDENING DRILL ROD



RECOMMENDED FOR USE WHERE SPECIAL TOOLS AND PARTS DEMAND SHOCK AND WEAR RESISTANCE. GROUND AND POLISHED, AND IDEALLY SUITED FOR SHAFTING APPLICATIONS. 36" LENGTH.

STOCK NO.	SIZE
DR01	1/8
DR02	3/16
DR03	1/4
DR04	5/16
DR05	3/8
DR06	1/2
DR07	5/8
DR08	3/4
DR09	7/8
DR10	1"

#### METRIC OIL DRILL ROD



36" LENGTH

STOCK NO.	SIZE
DR41	3mm
DR44	6mm
DR46	8mm
DR48	10mm
DR50	12mm
DR52	14mm
DR53	15mm
DR54	16mm
DR55	17mm
DR56	18mm
DR58	20mm
DR60	22mm
DR62	24mm
DR63	25mm

**ADDITIONAL SIZES AND GRADES OF DRILL ROD AVAILABLE UPON REQUEST**

**ADDITIONAL FLAT STOCK AVAILABLE UPON REQUEST**

#### (O-1) OIL HARDENING FLAT STOCK



A NON-SHRINKING DIE STEEL WHICH CAN BE HARDENED AT RELATIVELY LOW TEMPERATURES. SUITED FOR APPLICATIONS WHERE HIGH STRENGTH, ACCURACY AND PRECISION ARE REQUIRED. POLISHED AND GROUND. MADE TO EXACTING TOLERANCES. MANY MACHINE SHOP USES: DIES, TOOLS, PUNCHES AND TEMPLATES. 18" LENGTH.

STOCK NO.	THICKNESS	WIDTH
0037	1/16	1/2
0039	1/16	3/4
0040	1/16	1"
0069	3/32	1/2
0070	3/32	3/4
0071	3/32	1"
0073	3/32	1/2
FS00004	1/8	1/2
0099	1/8	3/4
FS00001	1/8	1"
0101	1/8	1-1/4
0102	1/8	1-1/2
0104	1/8	2"
0148	3/16	1/2
FS00027	3/16	3/4
FS00021	3/16	1"
0153	3/16	1-1/2
0180	1/4	1/2
FS00005	1/4	3/4
FS00002	1/4	1"
0185	1/4	1-1/2
0187	1/4	2"
0234	3/8	1/2
00044	3/8	3/4
0237	3/8	1"
0239	3/8	1-1/2
0241	3/8	2"
0265	1/2	1/2
0267	1/2	3/4
0268	1/2	1"
0270	1/2	1-1/2





**KEYSTOCK, ROUND BAR, B-7 STUDS AND DOUBLE-ENDED STUDS**

**SQUARE KEYSTOCK**



12" ZINC PLATED

STOCK NO.	SIZE
KS01	1/8
KS02	5/32
KS03	3/16
KS04	7/32
KS05	1/4
KS06	9/32
KS07	5/16
KS08	3/8
KS09	7/16
KS10	1/2
KS11	9/16
KS12	5/8
KS13	11/16
KS14	3/4
KS15	13/16
KS16	7/8
KS17	1"
KS18	1-1/8
KS20	1-1/4

36" PLAIN FINISH

STOCK NO.	SIZE
KS25	1/8
KS26	3/16
KS27	1/4
KS28	5/16
KS29	3/8
KS30	7/16
KS31	1/2
KS32	5/8
KS33	3/4
KS34	7/8
KS35	1"

METRIC 12" ZINC PLATED

STOCK NO.	SIZE
KS900	4mm
KS901	5mm
KS902	6mm
KS904	8mm
KS905	10mm
KS906	12mm
KS907	14mm
KS908	16mm
KS909	18mm
KS910	20mm
KS912	25mm

12" STAINLESS STEEL

STOCK NO.	SIZE
KS40	1/8
KS41	3/16
KS42	1/4
KS44	3/8
KS46	1/2

ADDITIONAL SIZES IN ALL ITEMS  
AVAILABLE UPON REQUEST

**RECTANGULAR KEYSTOCK**



12" ZINC PLATED

STOCK NO.	SIZE	STOCK NO.	SIZE
KS53	1/8 x 3/16	KS623	5/16 x 3/4
KS54	1/8 x 1/4	KS63	3/8 x 1/2
KS55	3/16 x 1/4	KS64	3/8 x 5/8
KS56	3/16 x 3/8	KS65	3/8 x 3/4
KS57	1/4 x 5/16	KS66	3/8 x 1"
KS58	1/4 x 3/8	KS67	1/2 x 5/8
KS59	1/4 x 1/2	KS68	1/2 x 3/4
KS592	1/4 x 5/8	KS681	1/2 x 1"
KS594	1/4 x 3/4	KS69	5/8 x 3/4
KS60	5/16 x 3/8	KS71	5/8 x 1"
KS61	5/16 x 1/2	KS72	3/4 x 1"
KS62	5/16 x 5/8		

**STEP KEYSTOCK**



12" ZINC PLATED

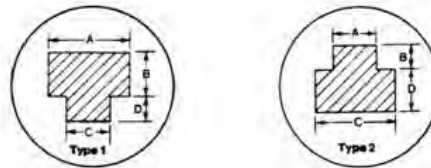

STOCK NO.	TYPE	DIMENSIONS			
		A	B	C	D
KS801	1	3/16	3/32	1/8	1/16
KS803	2	3/16	3/32	1/4	1/8
KS804	2	1/4	1/8	5/16	1/8
KS806	2	1/4	1/8	3/8	3/16
KS808	1	3/8	3/16	5/16	5/32
KS811	2	3/8	3/16	1/2	1/4
KS815	2	1/2	1/4	5/8	5/16

**DOUBLE-ENDED STUDS (USS - SAE)**  
GR. 5 MEDIUM CARBON HEAT-TREATED STEEL

(CALL US FOR THREAD LENGTH INFORMATION)



STOCK NO.	DIA.	SIZE	LENGTH
AV9668	1/4	x	1-1/4
AV9673	5/16	x	1"
AV9674	5/16	x	1-1/4
AV9675	5/16	x	1-1/2
AV9676	5/16	x	1-3/4
AV9677	5/16	x	2"
AV9678	5/16	x	2-1/2
AV9684	3/8	x	1-3/4
AV9687	3/8	x	2"
AV9689	3/8	x	2-3/4
AV9692	3/8	x	3-1/4
AV9702	7/16	x	2"
AV9731	1/2	x	2-1/2
AV9732	1/2	x	3"

**ROUND BAR (UNTHREADED ROD)**



36" ZINC PLATED

STOCK NO.	SIZE
K248	1/8
K250	1/4
K251	5/16
K252	3/8
K253	7/16
K254	1/2
K255	5/8
K266	3/4
K268	1"

36" BRASS

STOCK NO.	SIZE
CHD01	1/4
CHD02	5/16
CHD03	3/8
CHD04	1/2
CHD05	5/8
CHD06	3/4

36" STAINLESS STEEL

STOCK NO.	SIZE
S8980	1/4
S8981	5/16
S8982	3/8
S8984	1/2
S8985	5/8
S8986	3/4
S8988	1"

**B-7 STUDS**

ALLOY STEEL - PLAIN FINISH - COARSE THREAD



STOCK NO.	SIZE
K001	1/2 x 2-1/2
K002	1/2 x 2-3/4
K003	1/2 x 3"
K004	1/2 x 3-1/4
K005	1/2 x 5-3/4
K006	5/8 x 3"
K007	5/8 x 3-1/2
K008	5/8 x 4"
K0081	5/8 x 4-1/2
K0083	5/8 x 5-1/2
K009	5/8 x 6-1/2
K010	5/8 x 7-1/2
K011	3/4 x 3-1/4
K012	3/4 x 3-1/2
K013	3/4 x 3-3/4
K014	3/4 x 4"
K016	3/4 x 4-1/2
K017	3/4 x 4-3/4
K018	3/4 x 5"
K020	3/4 x 5-1/2
K021	3/4 x 6"
K022	3/4 x 8"
K023	7/8 x 4"
K024	7/8 x 5"

## RIVETS AND RIVET TOOLS

### POP RIVETS BUTTONHEAD

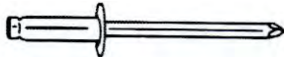

Stock No.	Rivet No.	Rivet Dia.	Grip Range	Use Drill #
<b>ALUMINUM</b>				
MARA42	AB4-2A	1/8	1/8	30
MARA43	AB4-3A	1/8	3/16	30
MARA44	AB4-4A	1/8	1/4	30
MARA45	AB4-5A	1/8	5/16	30
MARA46	AB4-6A	1/8	3/8	30
MARA48	AB4-8A	1/8	1/2	30
MARA53	AB5-3A	5/32	3/16	20
MARA54	AB5-4A	5/32	1/4	20
MARA58	AB5-8A	5/32	1/2	20
MARA62	AB6-2A	3/16	1/8	11
MARA64	AB6-4A	3/16	1/4	11
MARA66	AB6-6A	3/16	3/8	11
MARA68	AB6-8A	3/16	1/2	11
MARA612	AB6-12A	3/16	3/4	11
MARA616	AB6-16A	3/16	1"	11

### PAINTED ALUMINUM

Stock No.	Color	Rivet Dia.	Grip Range	Use Drill #
EVAA42DBRM	BROWN	1/8	1/8	30
EVAA42DWM	WHITE	1/8	1/8	30
EVAA43DBRM	BROWN	1/8	3/16	30
EVAA43DWM	WHITE	1/8	3/16	30
EVAA44DBRM	BROWN	1/8	1/4	30
EVAA44DWM	WHITE	1/8	1/4	30

### STEEL

MARS42	SB4-2	1/8	1/8	30
MARS43	SB4-3	1/8	3/16	30
MARS44	SB4-4	1/8	1/4	30
MARS45	SB4-5	1/8	5/16	30
MARS46	SB4-6	1/8	3/8	30
MARS48	SB4-8	1/8	1/2	30
MARS52	SB5-2	5/32	1/8	20
MARS53	SB5-3	5/32	3/16	20
MARS54	SB5-4	5/32	1/4	20
MARS56	SB5-6	5/32	3/8	20
MARS58	SB5-8	5/32	1/2	20
MARS64	SB6-4	3/16	1/4	11
MARS66	SB6-6	3/16	3/8	11
MARS68	SB6-8	3/16	1/2	11
MARS610	SB6-10	3/16	5/8	11
MARS612	SB6-12	3/16	3/4	11
MARS88	SB8-8	1/4	1/2	F
MARS812	SB8-12	1/4	3/4	F

### STAINLESS STEEL

MARSS42	SSB4-2S	1/8	1/8	30
MARSS43	SSB4-3S	1/8	3/16	30
MARSS44	SSB4-4S	1/8	1/4	30
MARSS46	SSB4-6S	1/8	3/8	30
MARSS48	SSB4-8S	1/8	1/2	30
MARSS64	SSB6-4S	3/16	1/4	11
MARSS66	SSB6-6S	3/16	3/8	11
MARSS68	SSB6-8S	3/16	1/2	11

### BACK-UP WASHERS

REINFORCING WASHERS FOR USE IN RIVETING SOFT MATERIALS OR TO COMPENSATE FOR OVERSIZE HOLES.

#### STEEL

STOCK NO. MARSS8 (DIA. 3/8 HOLE SIZE 1/8)

#### ALUMINUM

STOCK NO. MARAS10 (DIA. 1/2 HOLE SIZE 3/16)

### POP RIVETS LARGE FLANGE

Stock No.	Rivet No.	Rivet Dia.	Grip Range	Use Drill #
<b>STEEL</b>				
MARSL42	SBL4-2	1/8	1/8	30
MARSL44	SBL4-4	1/8	1/4	30
MARSL66	SBL6-6	3/16	3/8	11
MARSL68	SBL6-8	3/16	1/2	11
MARSL612	SBL6-12	3/16	3/4	11
<b>ALUMINUM</b>				
MARAL64	ABL64-A	3/16	1/4	11
MARAL66	ABL66-A	3/16	3/8	11
MARAL68	ABL68-A	3/16	1/2	11

### MONOBOLT RIVETS



STOCK NO.	DIA.	GRIP	MATERIAL
AV12089	3/16	3/8	STEEL
AV12086	1/4	3/8	ALUMINUM
AV12092	1/4	3/8	STEEL
AV12093	1/4	5/8	STEEL

### HAND RIVETERS

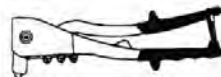

AN INDUSTRIAL QUALITY HEAVY DUTY RIVETING TOOL, WHICH INCLUDES NOSEPIECES FOR 3/32, 1/8, 5/32, AND 3/16 DIAMETERS- CUSHIONED GRIPS.

STOCK NO. EVDPP9

### BIG DADDY (UP TO 1/4 DIAMETER)



STANDARD NOSEPIECES INCLUDED ARE 5/32, 3/16, AND 1/4. SETTING OF 1/8 DIAMETER RIVETS REQUIRES A SPECIAL NOSEPIECE. THIS TOOL IS ALSO CAPABLE OF SETTING 3/16 AND 1/4 MONOBOLT RIVETS. WEIGHT 3 3/4 LBS.

STOCK NO. MAR39031

### HAND RIVETER KIT



INCLUDES THE HP-2 AND 200 ASSORTED KLIK-FAST RIVETS IN POPULAR SIZES. THE MOLDED PLASTIC CASE HOUSES AND PROTECTS THE TOOL, RIVETS AND OPTIONAL COUNTERSINK DOUBLE ENDED DRILL BIT.

STOCK NO. MAR39001

### AIR RIVET TOOL



THIS HEAVY DUTY TOOL SETS BLIND RIVETS FROM 3/32 TO 3/16 DIAMETER IN ALL RIVETS. IT IS ALSO CAPABLE OF SETTING 3/16 MONOBOLT RIVETS WITH A SPECIAL NOSEPIECE. STANDARD 1/8, 5/32, AND 3/16 NOSE PIECES INCLUDED, AS WELL AS SERVICE WRENCHES AND PLASTIC BOTTLE TO CATCH EJECTED MANDRELS. WEIGHT 3-1/2 LBS.

STOCK NO. MAR39054

### POP RIVET DRILL BITS



JOBBERS	STUB LENGTH		
STOCK NO.	SIZE	STOCK NO.	SIZE
VT114507	30	VT134308	30
VT114606	20	VT134407	20
VT114697	11	VT134498	11
VT116057	F		

### ROUND TYPE "U" DRIVE SCREWS ZINC PLATED



STOCK NO.	SIZE	BOX QTY.
DS01	#0 x 3/16	100
DS09	#2 x 3/16	100
DS10	#2 x 1/4	100
DS11	#2 x 3/8	100
DS13	#4 x 3/16	100
DS14	#4 x 1/4	100
DS19	#6 x 1/4	100
-	#6 x 1/2	-
DS23	#8 x 3/8	100
DS27	#10 x 3/8	100

### STEEL ROUND HEAD RIVETS



STOCK NO.	SIZE	BOX QTY.
JC01	1/8 x 1"	100
JC02	3/16 x 1-1/2	100
JC03	1/4 x 1-1/2	100
JC05	1/4 x 2-1/2	100
JC19	3/8 x 1-1/2	100

### MONOBOLT NOSE PIECE

TO BE USED WITH MAR39031 BIG DADDY RIVET TOOL.

STOCK NO.	SIZE
MAR96031	3/16
MAR96030	1/4

**O-RINGS AND E-CLIPS**

**RUBBER O-RINGS**



STOCK NO.	SIZE	
	ID	OD
OR006	1/8	x 1/4
OR007	5/32	x 9/32
OR008	3/16	x 5/16
OR009	7/32	x 11/32
OR010	1/4	x 3/8
OR011	5/16	x 7/16
OR012	3/8	x 1/2
OR110	3/8	x 9/16
OR013	7/16	x 9/16
OR111	7/16	x 5/8
OR014	1/2	x 5/8
OR112	1/2	x 11/16
OR113	9/16	x 3/4
OR016	5/8	x 3/4
OR114	5/8	x 13/16
OR017	11/16	x 13/16
OR115	11/16	x 7/8
OR018	3/4	x 7/8
OR116	3/4	x 15/16
OR210	3/4	x 1"
OR019	13/16	x 15/16
OR117	13/16	x 1"
OR211	13/16	x 1-1/16
OR020	7/8	x 1"
OR118	7/8	x 1-1/16
OR212	7/8	x 1-1/8
OR119	15/16	x 1-1/8
OR213	15/16	x 1-3/16
OR120	1"	x 1-3/16
OR214	1"	x 1-1/4
OR121	1-1/16	x 1-1/4
OR215	1-1/16	x 1-5/16
OR122	1-1/8	x 1-5/16
OR216	1-1/8	x 1-3/8
OR123	1-3/16	x 1-3/8
OR217	1-3/16	x 1-7/16
OR124	1-1/4	x 1-7/16
OR218	1-1/4	x 1-1/2
OR125	1-5/16	x 1-1/2
OR219	1-5/16	x 1-9/16
OR220	1-3/8	x 1-5/8
OR221	1-7/16	x 1-11/16
OR222	1-1/2	x 1-3/4
OR325	1-1/2	x 1-7/8
OR326	1-5/8	x 2"
OR224	1-3/4	x 2"
OR327	1-3/4	x 2-1/8
OR225	1-7/8	x 2-1/8
OR226	2"	x 2-1/4
OR330	2-1/8	x 2-1/2
OR331	2-1/4	x 2-5/8
OR333	2-1/2	x 2-7/8

ADDITIONAL SIZES AVAILABLE  
UPON REQUEST

**O-RING KITS**

**300 PIECE "FIX-KIT" IN PLASTIC CASE**



24 VARIETIES - 3/32 ID THROUGH 1-1/2 ID.

**STOCK NO. PB12930**

**300 PIECE "FIX-KIT" IN STEEL CASE**



20 VARIETIES - 1/8 ID THROUGH 1-1/16 ID

**STOCK NO. AV6085**

**382 PIECE KIT IN PLASTIC CASE**



30 VARIETIES - 1/8 ID THROUGH 1-3/4 ID  
UNIQUE PRONG AND HOLE STORAGE

**STOCK NO. APAG40E**

**O-RING SPLICE KIT**



INCLUDES 1 RAZOR BLADE, 1 CUTTING AND SPLICING JIG, 1 TUBE OF RAPID-SET ADHESIVE, AND 4 PIECES OF O-RING CORD STOCK IN 7 FT. LENGTHS. DIAMETERS: .103 (3/32), .139 (1/8), .210 (3/16), AND .275 (1/4). PLASTIC CASE.

**STOCK NO. AV12976**

**E-CLIPS**



**STOCK NO.                      SHAFT SIZE**

AV8824	1/16
AV8826	1/8
AV10131	5/32
AV8827	3/16
AV8828	1/4
AV3824	5/16
AV8829	3/8
AV8830	7/16
AV5602	1/2
AV5603	5/8
AV8831	3/4
AV8832	7/8
AV8833	1"

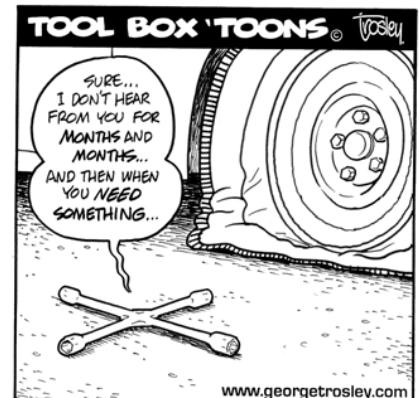

## SNAP RINGS

### EXTERNAL SNAP RINGS



STOCK NO.	SHAFT SIZE
SRE001	1/8
SRE003	3/16
SRE005	1/4
SRE006	9/32
SRE007	5/16
SRE008	11/32
SRE009	3/8
SRE011	7/16
SRE013	1/2
SRE014	9/16
SRE015	5/8
SRE016	11/16
SRE017	3/4
SRE018	13/16
SRE019	7/8
SRE020	15/16
SRE021	1"
SRE022	1-1/16
SRE023	1-1/8
SRE024	1-3/16
SRE025	1-1/4
SRE026	1-5/16
SRE027	1-3/8
SRE029	1-1/2
SRE033	1-3/4
SRE035	1-7/8
SRE037	2"
SRE041	2-1/4
SRE045	2-1/2

### INTERNAL SNAP RINGS



STOCK NO.	BORE SIZE
SRI001	1/4
SRI002	5/16
SRI003	3/8
SRI004	7/16
SRI005	1/2
SRI006	9/16
SRI007	5/8
SRI009	3/4
SRI011	7/8
SRI013	1"
SRI015	1-1/8
SRI017	1-1/4
SRI019	1-3/8
SRI021	1-1/2
SRI023	1-5/8
SRI025	1-3/4
SRI027	1-7/8
SRI029	2"

### SNAP RING KIT



1000 PIECE "FIX-KIT" IN STEEL CASE

24 VARIETIES - 1/4 THROUGH 1-1/4 SIZE RANGE EXTERNAL AND INTERNAL.

STOCK NO. AV6116

### METRIC EXTERNAL SNAP RINGS



STOCK NO.	SHAFT SIZE
SMRI001	2.5m
SMRI002	3m
SMRI003	3.5m
SMRI004	4m
SMRI005	5m
SMRI006	6m
SMRI007	7m
SMRI008	8m
SMRI009	9m
SMRI010	10m
SMRI011	11m
SMRI012	12m
SMRI013	13m
SMRI014	14m
SMRI015	15m
SMRI016	16m
SMRI017	17m
SMRI018	18m
SMRI019	19m
SMRI020	20m
SMRI021	21m
SMRI022	22m
SMRI023	23m
SMRI024	24m
SMRI025	25m
SMRI026	26m
SMRI027	27m
SMRI028	28m
SMRI029	29m
SMRI030	30m
SMRI031	31m
SMRI032	32m
SMRI033	33m
SMRI034	34m
SMRI035	35m
SMRI036	36m
SMRI037	37m
SMRI038	38m
SMRI039	39m
SMRI040	40m
SMRI041	41m
SMRI042	42m
SMRI043	43m
SMRI044	44m
SMRI045	45m
SMRI046	46m
SMRI047	47m
SMRI048	48m
SMRI049	49m
SMRI050	50m

ADDITIONAL SIZES AVAILABLE UPON REQUEST

### METRIC INTERNAL SNAP RINGS



STOCK NO.	BORE SIZE
SMRE001	2.5m
SMRE002	3m
SMRE003	3.5m
SMRE004	4m
SMRE005	5m
SMRE006	6m
SMRE007	7m
SMRE008	8m
SMRE009	9m
SMRE010	10m
SMRE011	11m
SMRE012	12m
SMRE013	13m
SMRE014	14m
SMRE015	15m
SMRE016	16m
SMRE017	17m
SMRE018	18m
SMRE019	19m
SMRE020	20m
SMRE021	21m
SMRE022	22m
SMRE023	23m
SMRE024	24m
SMRE025	25m
SMRE026	26m
SMRE027	27m
SMRE028	28m
SMRE029	29m
SMRE030	30m
SMRE031	31m
SMRE032	32m
SMRE033	33m
SMRE034	34m
SMRE035	35m
SMRE036	36m
SMRE037	37m
SMRE038	38m
SMRE039	39m
SMRE040	40m
SMRE041	41m
SMRE042	42m
SMRE043	43m
SMRE044	44m
SMRE045	45m
SMRE046	46m
SMRE047	47m
SMRE048	48m
SMRE049	49m
SMRE050	50m

CALL YOUR ORDER FOR PROMPT, COURTEOUS ASSISTANCE

**COTTER PINS AND CLEVIS PINS**

**COTTER PINS**



EXTENDED PRONG TAPER POINT

STOCK NO.	DIA.	SIZE		BOX QTY.
		x	LENGTH	
CP01	1/16	x	1/2	100
CP02	1/16	x	3/4	100
CP03	1/16	x	1"	100
CP031	1/16	x	1-1/4	100
CP04	1/16	x	1-1/2	100
CP05	1/16	x	2"	100
CP06	3/32	x	1/2	100
CP07	3/32	x	3/4	100
CP08	3/32	x	1"	100
CP085	3/32	x	1-1/4	100
CP09	3/32	x	1-1/2	100
CP10	3/32	x	2"	100
CP11	1/8	x	3/4	100
CP12	1/8	x	1"	100
CP13	1/8	x	1-1/4	100
CP14	1/8	x	1-1/2	100
CP145	1/8	x	1-3/4	100
CP15	1/8	x	2"	100
CP16	1/8	x	2-1/2	100
CP17	1/8	x	3"	100
CP18	5/32	x	1/2	100
CP185	5/32	x	3/4	100
CP19	5/32	x	1"	100
CP20	5/32	x	1-1/2	100
CP21	5/32	x	2"	100
CP22	5/32	x	2-1/2	100
CP23	5/32	x	3"	100
CP24	3/16	x	1"	100
CP25	3/16	x	1-1/4	100
CP26	3/16	x	1-1/2	100
CP27	3/16	x	2"	100
CP29	3/16	x	2-1/2	100
CP30	3/16	x	3"	100
CP31	3/16	x	3-1/2	100
CP32	3/16	x	4"	100
CP34	1/4	x	1-1/4	100
CP35	1/4	x	1-1/2	100
CP37	1/4	x	2"	100
CP38	1/4	x	2-1/2	100
CP39	1/4	x	3"	50
CP40	1/4	x	3-1/2	50
CP41	1/4	x	4"	50
CP42	1/4	x	6"	50
CP43	5/16	x	2"	50
CP44	5/16	x	2-1/2	50
CP45	5/16	x	3"	50
CP46	5/16	x	3-1/2	25
CP47	5/16	x	4"	25
CP472	5/16	x	5"	25
CP48	3/8	x	2"	25
CP49	3/8	x	2-1/2	25
CP50	3/8	x	3"	25
CP51	3/8	x	3-1/2	25
CP52	3/8	x	4"	25
CP53	3/8	x	5"	25
CP545	3/8	x	6"	25
CP55	1/2	x	3"	25
CP56	1/2	x	4"	25
CP565	1/2	x	5"	25
CP57	1/2	x	6"	25
CP58	5/8	x	6"	-

**COTTER PIN ASSORTMENT**



**420 TOTAL PIECES - PLASTIC CASE**

DIA.	x	LENGTH
1/16	x	1"
3/32	x	1"
1/8	x	1-1/2
5/32	x	1-1/2
3/16	x	1-1/2
1/4	x	2"

**STOCK NO. BEE250500**

**HAMMERLOCK FIX KIT  
1500 PIECES**



**16 VARIETIES - HAMMERLOCK  
COTTER PINS - BRIGHT ZINC CHROMATE  
STEEL CASE**

**SIZES**

1/16 x 1/2	3/32 x 3/4	1/8 x 1"	1/8 x 2-1/2
1/16 x 3/4	3/32 x 1"	1/8 x 1-1/4	5/32 x 1"
1/16 x 1"	3/32 x 1-1/2	1/8 x 1-1/2	5/32 x 1-1/2
1/16 x 1-1/2	3/32 x 2"	1/8 x 2"	5/32 x 2"

**STOCK NO. AV6112**

**YOKE ENDS**



STOCK NO.	SIZE
AV10737	1/4-28
AV10738	5/16-24

**BALL JOINT ASSEMBLIES**

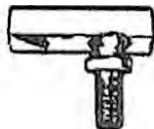

STOCK NO.	SIZE
AV13582	1/4-28
AV13584	5/16-24
AV9869	3/8-24

**UNIVERSAL  
CLEVIS PINS**



A REPLACEMENT PIN WITH MULTIPLE HOLES FOR QUICK AND EASY ADJUSTMENT.

STOCK NO.	SIZE
CLP02	1/4 x 2"
CLP03	5/16 x 2"
CLP04	3/8 x 2"
CLP05	7/16 x 2"
CLP06	1/2 x 2"
CLP07	5/8 x 3"
CLP08	3/4 x 3"

**STANDARD CLEVIS PINS  
DRILLED FOR COTTER PINS**



AVAILABLE PER REQUEST- INCLUDE THE FOLLOWING WHEN ORDERING:

- \*PIN DIAMETER
- \*LENGTH UNDER HEAD TO END OF PIN
- \*LENGTH UNDER HEAD TO DRILLED HOLE
- \*AVAILABLE DIAMETERS- 3/16 THRU 1"
- \*ALSO AVAILABLE IN STAINLESS STEEL

**SAVE TIME AND MONEY**

**TO SAVE OUR CUSTOMERS  
THE DELAY AND BOTHER  
OF HUNTING  
THROUGH MANY SOURCES  
OF SUPPLY,  
WE CAN FURNISH MANY ITEMS  
NOT LISTED  
IN THIS CATALOG**



## HITCH PINS AND SPRING PINS

### HITCH PIN CLIPS



ZINC PLATED SPRING WIRE

\*ALSO KNOWN AS BRIDGE PIN OR HAIRPIN  
 \*CAN BE INSERTED AND REMOVED WITH EASE  
 \*REUSABLE

STOCK NO.	MAX SHAFT	WIRE DIA.	OVERALL LENGTH	DRILL SIZE	BOX QTY.
HP23P	3/8	.042	1"	3/64	100
HP24P	3/8	.047	1-5/8	1/16	100
HP22P	1/2	.062	1-5/16	5/64	100
HP13P	3/8	.080	1-1/4	1/4	100
HP17P	1/2	.080	1-5/8	3/32	100
HP3P	1/2	.094	1-5/8	7/64	100
HP28P	1/2	.094	2"	7/64	100
HP7P	5/8	.094	2-5/16	7/64	100
HP11P	3/4	.125	2-5/8	9/64	100
HP10P	1"	.148	3"	5/32	100
HP8P	1"	.177	3-3/4	3/16	100
HP19P	1"	.243	4"	17/64	-
HP20P	1"	.310	4"	21/64	-

### HITCH PIN



EASY SWIVEL PULL RING AND A HIGH TENSION HAIRPIN COTTER. ALL HITCH PINS ARE ZINC PLATED WITH A YELLOW DICHROMATE DIP FOR CORROSION RESISTANCE. HAIRPIN COTTER INCLUDED.

STOCK NO.	DIA.	LENGTH UNDER COLLAR TO HOLE	QTY.
HP002	3/8	4"	1
003	3/8	4-1/4	1
004	1/2	3"	1
HP005	1/2	3-1/2	1
006	1/2	4"	1
HP007	1/2	4-1/4	1
HP008	1/2	5-3/4	1
HP009	5/8	4"	1
010	5/8	4-1/4	1
HP011	5/8	4-1/2	1
012	5/8	5"	1
HP013	5/8	5-3/4	1
014	5/8	6"	1
HP015	5/8	6-1/4	1
017	3/4	4"	1
HP018	3/4	4-1/4	1
HP019	3/4	5-1/4	1
HP020	3/4	6-1/4	1
HP023	7/8	4-1/4	1
HP024	7/8	6-1/4	1
025	7/8	6-1/2	1
HP026	7/8	7"	1
HP031	1"	4-1/4	1
032	1"	4-3/4	1
HP033	1"	6-1/4	1
034	1"	6-3/4	1
HP035	1"	7"	1

### SPRING PINS

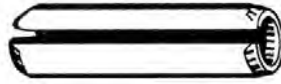

PLAIN FINISH AND HEAT TREATED

STOCK NO.	DIA.	SIZE x LENGTH	BOX QTY.
SP01	1/16	x 1/2	100
SP012	1/16	x 3/4	100
SP02	1/16	x 1"	100
SP022	5/64	x 3/4	100
SP023	5/64	x 1"	100
SP03	3/32	x 1/2	100
SP035	3/32	x 5/8	100
SP04	3/32	x 3/4	100
SP05	3/32	x 1"	100
SP06	3/32	x 1-1/2	100
SP07	1/8	x 1/2	100
SP08	1/8	x 3/4	100
SP09	1/8	x 1"	100
SP10	1/8	x 1-1/4	100
SP11	1/8	x 1-1/2	100
SP115	1/8	x 1-3/4	100
SP12	1/8	x 2"	100
SP126	5/32	x 1/2	100
SP128	5/32	x 5/8	100
SP13	5/32	x 3/4	100
SP14	5/32	x 1"	100
SP15	5/32	x 1-1/4	100
SP16	5/32	x 1-1/2	100
SP17	5/32	x 2"	100
SP18	5/32	x 2-1/2	100
SP19	3/16	x 3/4	100
SP191	3/16	x 7/8	100
SP20	3/16	x 1"	100
SP21	3/16	x 1-1/4	100
SP22	3/16	x 1-1/2	100
SP23	3/16	x 2"	100
SP24	3/16	x 2-1/2	100
SP241	3/16	x 3"	100
SP25	7/32	x 1"	100
SP252	7/32	x 2"	100
SP26	1/4	x 3/4	50
SP265	1/4	x 7/8	50
SP27	1/4	x 1"	50
SP28	1/4	x 1-1/4	50
SP29	1/4	x 1-1/2	50
SP295	1/4	x 1-3/4	50
SP30	1/4	x 2"	50
SP305	1/4	x 2-1/4	50
SP31	1/4	x 2-1/2	50
SP32	1/4	x 3"	50
SP321	1/4	x 3-1/2	50
SP325	5/16	x 1"	50
SP33	5/16	x 1-1/4	50
SP335	5/16	x 1-1/2	50
SP338	5/16	x 2"	50
SP34	5/16	x 2-1/2	50
SP341	5/16	x 3"	50
SP35	3/8	x 1-1/2	25
SP354	3/8	x 1-3/4	25
SP36	3/8	x 2"	25
SP365	3/8	x 2-1/2	25
SP37	3/8	x 3"	25
SP38	3/8	x 3-1/4	25
SP39	3/8	x 4"	25
SP396	3/8	x 6"	25
SP3989	7/16	x 3"	25
SP40	1/2	x 2"	25
SP43	1/2	x 3"	25
SP45	1/2	x 4"	25
SP49	1/2	x 6"	25

### SPRING PIN ASSORTMENT



170 TOTAL PIECES - PLASTIC CASE

DIA.	x	LENGTH
1/8	x	1-1/2
3/16	x	1-1/2
7/32	x	1-1/2
1/4	x	1-1/2
5/16	x	1-1/2
3/8	x	1-1/2

STOCK NO. BEE450500

### SPRING PIN KIT



1475 PIECES - STEEL CASE  
 24 VARIETIES- 4 DIAMETERS- ZINC PLATED

#### SIZES

1/16 x 3/16	5/64 x 1/4	3/32 x 5/16	1/8 x 3/8
1/16 x 1/2	5/64 x 1/2	3/32 x 1/2	1/8 x 1/2
1/16 x 3/4	5/64 x 3/4	3/32 x 3/4	1/8 x 3/4
1/16 x 1"	5/64 x 1"	3/32 x 1"	1/8 x 1"
		3/32 x 1-1/4	1/8 x 1-1/4
		3/32 x 1-1/2	1/8 x 1-1/2
			1/8 x 1-3/4
			1/8 x 2"

STOCK NO. AV6124

QUALITY PRODUCTS, FAIR AND  
 COMPETITIVE PRICES, AND  
 EXCELLENT SERVICE IS  
 OUR REPUTATION

**SHAFT COLLARS, MACHINERY BUSHINGS AND TAPER PINS**

**SHAFT COLLARS**



STEEL- ZINC PLATED- HEX SET SCREW

STOCK NO.	I.D.	O.D.	WIDTH
PR001	1/8	3/8	1/4
PR002	3/16	7/16	1/4
PR003	1/4	1/2	5/16
PR004	5/16	5/8	5/16
PR005	3/8	3/4	3/8
PR007	1/2	1"	7/16
PR009	5/8	1-1/8	1/2
PR011	3/4	1-1/4	9/16
PR013	7/8	1-1/2	9/16
PR015	1"	1-5/8	5/8
PR017	1-1/8	1-3/4	5/8
-	1-3/16	2"	11/16
PR019	1-1/4	2"	11/16
PR021	1-3/8	2-1/8	3/4
PR023	1-1/2	2-1/4	3/4
PR031	2"	3"	7/8

**SINGLE SPLIT COLLARS**



STAINLESS STEEL

STOCK NO.	SIZE
PR0992	1/4
PR0993	5/16
PR0994	3/8
	7/16
PR0996	1/2
PR0998	5/8

**DOUBLE SPLIT COLLARS**



STOCK NO.	SIZE
PR040	1/4
PR042	3/8
PR044	1/2
PR046	5/8
PR048	3/4
PR050	7/8
PR052	1"
PR053	1-1/8
-	1-3/16
PR056	1-1/4
PR057	1-3/8
PR058	1-1/2

**MACHINERY BUSHINGS**



REGULAR MACHINE BUSHINGS 18 GAUGE

STOCK NO.	I.D.	O.D.	GAUGE
BUSH1002	1/2	7/8	18
BUSH1004	5/8	1"	18
BUSH1005	3/4	1-1/4	18
BUSH1006	7/8	1-3/8	18
BUSH1007	1"	1-1/2	18
BUSH1009	1-1/4	1-7/8	18
BUSH1011	1-1/2	2-1/4	18

REGULAR MACHINE BUSHINGS 14 GAUGE

BUSH1021	1/2	7/8	14
BUSH1023	5/8	1"	14
BUSH1024	3/4	1-1/4	14
BUSH1025	7/8	1-3/8	14
BUSH1026	1"	1-1/2	14
BUSH1028	1-1/4	1-7/8	14
BUSH1030	1-1/2	2-1/4	14

WIDE MACHINE BUSHINGS 18 GAUGE

BUSH1059	5/8	1-1/4	18
BUSH1060	3/4	1-1/2	18
BUSH1061	7/8	1-3/4	18
BUSH1063	1"	2"	18
BUSH1066	1-1/4	2-1/4	18
BUSH1068	1-1/2	3"	18

WIDE MACHINE BUSHINGS 14 GAUGE

BUSH1079	5/8	1-1/4	14
BUSH1080	3/4	1-1/2	14
BUSH1081	7/8	1-3/4	14
BUSH1083	1"	2"	14
BUSH1086	1-1/4	2-1/4	14
BUSH1088	1-1/2	3"	14

**TAPER PINS**



STOCK NO.	NUMBER	SIZE x	LENGTH
TP01	7/0	x	3/4
TP02	5/0	x	1"
TP03	4/0	x	1"
TP04	3/0	x	1"
TP05	2/0	x	1-1/2
TP06	0	x	2"
TP07	0	x	3"
TP08	1	x	2-1/2
TP09	1	x	3"
TP10	1	x	5"
TP106	2	x	1-1/2
TP11	2	x	2-1/2
TP12	2	x	5"
TP126	3	x	1-1/2
TP13	3	x	2-1/2
TP132	3	x	3"
TP14	3	x	5"
TP15	4	x	1-1/4
TP153	4	x	2"
TP16	4	x	2-1/2
TP166	4	x	4"
TP17	4	x	5"
TP174	5	x	1"
TP178	5	x	2"
TP179	5	x	2-1/2
TP18	5	x	3"
TP184	5	x	4"
TP19	5	x	5"
TP194	6	x	1-1/4
TP195	6	x	1-1/2
TP20	6	x	3"
TP21	6	x	5"
TP22	7	x	3"
TP224	7	x	4"
TP226	7	x	4-1/2
TP23	7	x	5"
TP24	7	x	6"
TP244	8	x	1-1/2
TP245	8	x	1-3/4
TP25	8	x	3"
TP255	8	x	4"
TP26	8	x	5"
TP27	8	x	6"
TP276	9	x	4"
TP278	9	x	5"
TP28	9	x	6"
TP29	10	x	4"
TP295	10	x	5"
TP30	10	x	5-1/2
TP31	10	x	6"

**ADDITIONAL ITEMS  
AVAILABLE.**



**CALL  
FOR  
DETAILS.**



**CALL US FOR ALL YOUR NEEDS**  
**855-785-TOOL**

## WOODRUFF KEYS, ROUND SHAFT KEYS, MOTOR ARBORS & RELATED ACCESSORIES

### WOODRUFF KEYS

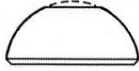

STOCK NO.	SIZE		KEY NUMBER
	WIDTH	x LGTH	
WK00	3/32	x 1/2	2
WK01	3/32	x 5/8	4
WK02	1/8	x 1/2	3
WK03	1/8	x 5/8	5
WK04	1/8	x 3/4	7
WK05	5/32	x 5/8	6
WK07	5/32	x 3/4	8
WK075	5/32	x 7/8	10
WK08	3/16	x 5/8	61
WK09	3/16	x 3/4	9
WK10	3/16	x 7/8	11
WK11	3/16	x 1"	13
WK12	3/16	x 1-1/8	16
WK121	3/16	x 1-1/4	19
WK13	7/32	x 7/8	12
WK14	7/32	x 1"	14
WK145	7/32	x 1-1/8	17
WK15	1/4	x 3/4	91
WK16	1/4	x 7/8	A
WK17	1/4	x 1"	15
WK175	1/4	x 1-1/8	18
WK18	1/4	x 1-1/4	21
WK182	1/4	x 1-1/2	24
WK19	5/16	x 1"	B
WK195	5/16	x 1-1/8	C
WK20	5/16	x 1-1/4	D
WK25	3/8	x 1-1/4	E

### WOODRUFF KEY ASSORTMENT



72 TOTAL PIECES - PLASTIC CASE

WIDTH	SIZE		KEY NUMBER
	x	LGTH	
1/8	x	1/2	3
1/8	x	5/8	5
5/32	x	5/8	6
3/16	x	3/4	9
1/4	x	7/8	A
1/4	x	1"	15

STOCK NO. BEE350500

### METRIC ROUND SHAFT KEY



STOCK NO.	SIZE		LENGTH
	WIDTH	THICKNESS	
KS9152	2	2	10
KS9197	4	4	36
KS9260	8	7	30
KS9315	12	8	25
KS9317	12	8	30
KS9321	12	8	40
KS9323	12	8	50
KS9334	12	8	100
KS9370	16	10	40

ADDITIONAL SIZES AVAILABLE UPON REQUEST

### MOTOR ARBORS



USE THESE HANDY ATTACHMENTS TO MOUNT VARIOUS WHEELS ON ELECTRIC MOTORS. PRECISION-MACHINED FROM COLD-ROLLED STEEL BARS. EACH ARBOR COMES WITH A HEX NUT AND A PAIR OF WASHERS. STANDARD TYPE ARBORS HAVE A 1/2" DIAMETER THREADED PORTION THAT IS 1-13/16" LONG, WHICH HANDLES WHEELS UP TO 1-1/4" THICK.

RH THREAD IS FOR COUNTER-CLOCKWISE ROTATION (FACING SHAFT).  
LH THREAD IS FOR CLOCKWISE ROTATION (FACING SHAFT).

STOCK NO.	SIZE	THREAD
CLE007	1/2"	RH
CLE008	5/8"	RH
CLE009	1/2"	LH
CLE010	5/8	LH

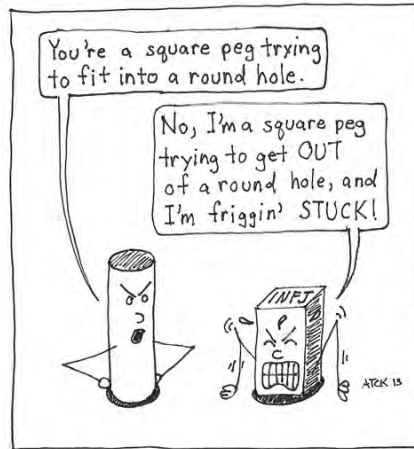

### BRONZE BUSHINGS



SELF-OILING. IDEAL FOR MOTORS, PULLEYS, REPAIR JOBS, ETC. STRAIGHT-SLEEVE TYPE.

STOCK NO.	ID	SIZE	OD	OVERALL LENGTH
CLE030	1/4	x	5/16	3/4
CLE031	1/4	x	3/8	1"
CLE032	3/8	x	1/2	1"
CLE033	1/2	x	5/8	1-1/8
CLE034	1/2	x	11/16	1-1/8
CLE035	1/2	x	3/4	1-1/8
CLE036	5/8	x	3/4	1"
CLE037	5/8	x	3/4	1-1/8
CLE038	3/4	x	1"	1-1/8

### STEEL BUSHINGS



SPLIT STEEL REDUCER BUSHINGS WITH A 3/16" KEYWAY SLOT. RUST-PROOF PLATED FINISH.

STOCK NO.	ID	SIZE	OD	OVERALL LENGTH
CLE050	1/4	x	5/16	1"
CLE051	1/4	x	3/8	1-1/16
CLE052	5/16	x	3/8	1-1/16
CLE053	3/8	x	7/16	1-1/16
CLE054	3/8	x	1/2	1"
CLE055	1/2	x	5/8	1-1/4
CLE057	5/8	x	3/4	1-1/4
CLE058	3/4	x	1"	1-1/4
CLE059	7/8	x	1"	1-5/16

### FLEXIBLE COUPLINGS



ONE-PIECE FOR DIRECT-DRIVE EQUIPMENT. FEATURES FLEXIBLE RUBBER SLEEVE WITH KNURLED STEEL HUB INSERTS ON EACH END. LOCKS TO SHAFT WITH SOCKET SET SCREWS (INCLUDED). COUPLING PERMITS MISALIGNMENT UP TO 1/8" PARALLEL AND UP TO 7 DEGREES ANGULAR. RATED CAPACITY 1/2 HP AT 1725 RPM.

STOCK NO.	BORE	OD	OVERALL LENGTH
CLE089	1/2	1-1/8	2-1/2
CLE090	1/2	1-1/8	3"
CLE091	1/2	1-1/8	3-1/2

### RIGID STEEL COUPLINGS



PRECISION-MACHINED FROM STEEL BARS. IDEAL FOR APPLICATIONS WHERE ALIGNMENT IS CRITICAL. LOCKS SECURELY TO SHAFT WITH SOCKET SET SCREWS (INCLUDED). BORES 1/2" & LARGER HAVE KEYWAYS.

STOCK NO.	BORE	OD	OAL	KEYWAY HGT.	x	WDTH.
CLE080	1/4	1/2	3/4	-	-	-
CLE081	5/16	5/8	1"	-	-	-
CLE082	3/8	3/4	1"	-	-	-
CLE083	1/2	1"	1-1/2	1/16	x	1/8
CLE084	5/8	1-1/4	2"	3/32	x	3/16
CLE085	3/4	1-1/4	2"	3/32	x	3/16



**COMPRESSION AND EXTENSION SPRINGS**



TYPE A- COMPRESSION



TYPE B- EXTENSION

STOCK NO.	TYPE	WIRE DIA.	O.D. IN.	OVERALL LENGTH
SAS001	A	.022	3/16	1-5/16
SAS002	A	.032	7/32	1-1/4
SAS003	A	.026	5/16	1-7/8
SAS004	A	.041	5/16	2-5/16
SAS005	A	.023	1/4	2"
SAS006	A	.020	5/16	1-1/2
SAS007	A	.041	5/16	1-3/8
SAS008	A	.047	11/16	2"
SAS009	A	.015	7/32	1-5/8
SAS010	A	.072	5/8	2"
SAS011	A	.041	5/8	1"
SAS012	A	.054	1/2	1-3/4
SAS013	A	.091	5/8	1-3/4
SAS014	A	.080	15/32	2-3/8
SAS015	A	.080	11/16	1-1/2
SAS016	B	.020	5/32	1-7/8
SAS017	B	.035	1/4	2-1/2
SAS018	B	.032	1/4	2-1/4
SAS019	B	.047	3/8	2-11/16
SAS020	B	.041	5/16	2-11/16
SAS021	B	.054	15/32	2-7/16
SAS022	B	.035	3/8	2"
SAS023	B	.062	7/16	2-15/16
SAS024	A	.032	13/64	2-1/4
SAS025	B	.041	13/32	2-3/4
SAS026	B	.062	1/2	2-5/16
SAS027	*	.073	1/2	*
SAS028	A	.047	15/32	1-1/8
SAS029	B	.08	1/2	1-11/16
SAS030	B	.105	3/4	1-3/4
SAS031	B	.105	3/4	1-15/16
SAS032	B	.105	3/4	2-1/8
SAS033	B	.105	3/4	2-5/16
SAS034	B	.105	3/4	2-5/8
SAS035	B	.105	3/4	2-13/16
SAS036	B	.105	3/4	3"
SAS037	B	.105	3/4	3-3/8
SAS038	A	.047	7/16	3"
SAS039	B	.062	1/2	3-5/8
SAS040	A	.062	7/16	3-1/4
SAS041	B	.041	1/2	3-13/16
SAS042	B	.047	7/16	3-11/16
SAS043	B	.041	5/16	3-7/16
SAS044	A	.047	2/64	3-5/16
SAS045	A	.041	9/32	2-11/16
SAS046	A	.062	1/2	2-13/16
SAS047	A	.062	11/16	3"
SAS048	A	.047	3/4	3-3/8
SAS049	A	.080	7/8	3-7/16
SAS050	A	.105	31/32	3-3/4
SAS051	B	.072	9/16	3-7/8
SAS052	A	.062	13/16	3-5/16

\* TORSION SPRING

STOCK NO.	TYPE	WIRE DIA.	O.D. IN.	OVERALL LENGTH
SAS053	A	.105	3/4	3"
SAS054	A	.135	1"	3-7/8
SAS055	A	.041	15/32	5-1/4
SAS056	B	.062	5/8	5-3/8
SAS057	B	.080	1/2	6"
SAS058	B	.080	5/8	5-7/8
SAS059	B	.041	21/32	4-7/8
SAS060	A	.080	7/16	5"
SAS061	B	.035	11/32	4"
SAS062	A	.072	5/8	3-3/4
SAS063	A	.12	15/16	9-1/2
SAS064	B	.062	1/2	9-3/4
SAS065	B	.041	9/32	6-1/2
SAS066	B	.047	15/32	6-3/4
SAS067	B	.105	3/4	8"
SAS068	A	.120	1-1/32	5-3/8
SAS069	A	.120	1-1/4	4"
SAS070	B	.047	7/16	5"
SAS119	B	.028	1/4	3/4
SAS120	B	.015	7/32	1-5/8
SAS121	B	.023	5/32	1-3/16
SAS122	B	.041	3/8	1-15/32
SAS123	A	.026	1/4	2-5/8
SAS124	A	.041	7/32	1-1/2
SAS125	A	.026	9/32	2-5/16
SAS126	A	.020	3/16	7/8
SAS127	A	.031	3/8	29/32
SAS128	A	.041	3/8	1-5/16
SAS129	A	.047	23/64	1-9/32
SAS130	A	.080	9/16	1-3/4
SAS131	A	.047	5/8	1-1/16
SAS132	A	.062	13/32	2"
SAS133	B	.032	1/4	1-3/4
SAS134	A	.030	1/4	1-1/16
SAS135	A	.036	5/16	1-1/16
SAS136	A	.054	3/8	1-3/16
SAS137	A	.032	9/32	2-1/2
SAS138	A	.028	21/64	2-1/2
SAS139	A	.028	9/32	2-3/8
SAS140	A	.047	13/32	1-3/16
SAS141	A	.072	31/64	1-1/4
SAS142	A	.026	17/64	2-3/8
SAS143	A	.036	15/64	2-1/2
SAS144	A	.028	15/64	1"
SAS145	A	.034	1/4	1-1/8
SAS146	A	.032	5/16	1-3/8
SAS147	A	.023	5/16	2"
SAS148	A	.028	3/8	1-5/32
SAS149	A	.031	11/32	1-15/16
SAS150	A	.026	15/16	2-5/8
SAS151	A	.032	9/32	2-11/16

STOCK NO.	TYPE	WIRE DIA.	O.D. IN.	OVERALL LENGTH
SAS152	A	.047	1/2	2-1/2
SAS153	A	.054	1/2	1-9/16
SAS154	A	.080	29/32	1-1/16
SAS155	A	.062	3/4	2-3/16
SAS156	A	.034	29/32	2-11/16
SAS157	B	.034	3/8	1-15/32
SAS158	B	.031	1/4	1-9/16
SAS159	B	.026	9/32	2-1/4
SAS160	B	.031	3/16	2-9/16
SAS161	A	.092	23/32	2-3/8
SAS162	B	.1055	3/4	1-3/4
SAS163	B	.1055	3/4	2"
SAS164	B	.1055	3/4	2-1/4
SAS165	B	.1055	3/4	2-7/16
SAS166	B	.1055	3/4	2-5/8
SAS167	B	.1055	3/4	2-7/8
SAS168	B	.1055	3/4	3"
SAS169	B	.1055	3/4	3-7/16
SAS170	B	.1055	3/4	3-13/16
SAS171	B	.1055	3/4	4-5/32
SAS172	A	.125	53/64	4-1/4
SAS173	A	.125	1"	4-7/16
SAS174	A	.091	23/32	4-1/4
SAS175	B	.072	23/32	4-3/8
SAS176	B	.091	21/32	3-15/16
SAS177	B	.035	17/64	4-1/8
SAS178	A	.054	1/2	3-9/16
SAS179	B	.036	5/16	3-3/4
SAS180	B	.023	3/16	3-9/16
SAS181	A	.054	9/16	3-1/16
SAS182	A	.047	53/64	3"
SAS183	A	.028	1/4	3-1/4
SAS184	A	.031	17/64	3-1/16
SAS185	A	.048	7/16	3"
SAS186	B	.032	1/4	4-3/4
SAS187	B	.047	3/8	5-3/16
SAS188	B	.041	5/16	6"
SAS189	B	.041	3/8	6-1/4
SAS190	B	.054	7/16	6-3/16
SAS191	B	.062	23/32	3-1/4
SAS192	B	.036	5/16	2-13/16
SAS193	B	.054	1/2	9"
SAS194	B	.062	5/8	8-3/8
SAS195	B	.080	3/4	7-3/8
SAS196	A	.080	5/8	6-3/8
SAS197	B	.080	5/8	2-7/8
SAS198	B	.080	45/64	10"
SAS199	A	.080	1/2	5-1/2
SAS200	B	.072	13/16	10-1/4
SAS201	A	.125	15/16	6-7/8
SAS202	A	.125	13/16	10"
SAS203	B	.135	55/64	8-1/2

ADDITIONAL SPRINGS AVAILABLE  
UPON REQUEST

ADDITIONAL SPRINGS AVAILABLE  
UPON REQUEST

ADDITIONAL SPRINGS AVAILABLE  
UPON REQUEST

## THREADED INSERTS



AUTOMATIC SELF-LOCKING EXTERNAL THREAD WITH USE-ACTIVATED EPOXY ADHESIVE



DRILL WITH STANDARD DRILL, TAP HOLE WITH STANDARD TAP, AND TURN EZ LOK FLUSH WITH BOLT, STUD OR SPARK PLUG.

STOCK NO.	INTERNAL THREAD	EXTERNAL THREAD	TAP DRILL SIZE
EZ3293	10-24	3/8-16	5/16
EZ3294	1/4-20	7/16-14	U
EZ329428	1/4-28	7/16-14	U
EZ3295	5/16-18	1/2-13	27/64
EZ329524	5/16-24	1/2-13	27/64
EZ3296	3/8-16	9/16-12	31/64
EZ329624	3/8-24	9/16-12	31/64
EZ3297	7/16-14	5/8-11	17/32
EZ329720	7/16-20	5/8-11	17/32
EZ3298	1/2-13	3/4-10	21/32
EZ329820	1/2-20	3/4-10	21/32
EZ3299	9/16-12	3/4-10	21/32
EZ32910	5/8-11	7/8-9	49/64
EZ32910F	5/8-18	7/8-9	49/64
EZ32912	3/4-10	1"-8	7/8
EZ3291216	3/4-16	1"-8	7/8
EZ32914	7/8-9	1-1/4-7	1-7/64
EZ32916	1-8	1-3/8-12	1-9/32

**STAINLESS STEEL**

STOCK NO.	INTERNAL THREAD	EXTERNAL THREAD	TAP DRILL SIZE
EZ303004	4-40	10-32	#21
EZ303006	6-32	1/4-20	#7
EZ303008	8-32	5/16-18	F
EZ3033	10-24	3/8-16	5/16
EZ3034	1/4-20	7/16-14	U

**METRIC**

STOCK NO.	INTERNAL THREAD	EXTERNAL THREAD	TAP DRILL SIZE
EZ4506	M6X1.0	M10X1.5	8.6MM
EZ4508	M8X1.25	M12X1.75	10.2MM
EZ45010	M10X1.5	M16X2.0	14MM
EZ65010	M10X1.5	9/16-12	31/64
EZ45012	M12X1.75	M16X2.0	14MM

**E-Z LOCK THREAD REPAIR KIT**



PACKAGED IN HEAVY-DUTY, WELDED STEEL BOX WITH HINGED LID AND SNAP LOCK. COARSE THREAD #10 to 1/2". INCLUDES 10 INSERTS OF 10-24, 10 OF 1/4-20, 10 OF 5/16-18, 10 OF 3/8-16, AND 6 OF 1/2-13.

STOCK NO. EZC108



**INSTALLATION**

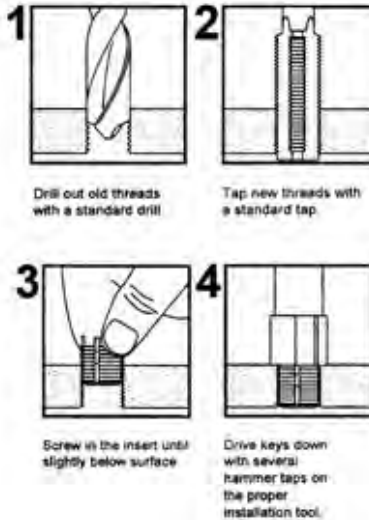

STOCK NO.	INTERNAL THREAD	EXTERNAL THREAD	TAP DRILL SIZE
RL73042	1/4-20	7/16-14	X
RL74042	1/4-28	7/16-14	X
RL73052	5/16-18	1/2-13	29/64
RL74052	5/16-24	1/2-13	29/64
RL73062	3/8-16	9/16-12	33/64
RL74062	3/8-24	9/16-12	33/64
RL73082	1/2-13	3/4-16	45/64
RL74082	1/2-20	3/4-16	45/64
RL73102	5/8-11	7/8-14	53/64
RL74102	5/8-18	7/8-14	53/64
RL73122	3/4-10	1-1/8-12	1-1/16
RL74122	3/4-16	1-1/8-12	1-1/16

**QUESTIONS OR COMMENTS REGARDING THIS CATALOG?**

**DROP US A LINE!**

**SCREW THREAD INSERTS**



STOCK NO.	INTERNAL THREAD	INSTALLED LENGTH
HCI020	6-32	.207
HCI026	8-32	.246
HCI032	10-24	.285
HCI035	10-32	.285
HCI038	12-24	.324
HCI041	1/4-20	.375
HCI042	1/4-20	.500
HCI044	1/4-28	.375
HCI047	5/16-18	.469
HCI050	5/16-24	.469
HCI052	3/8-16	.375
HCI053	3/8-16	.562
HCI054	3/8-16	.750
HCI056	3/8-24	.562
HCI059	7/16-14	.656
HCI062	7/16-20	.656
HCI064	1/2-13	.500
HCI065	1/2-13	.750
HCI068	1/2-20	.750
HCI071	9/16-12	.844
HCI074	9/16-18	.844
HCI077	5/8-11	.938
HCI078	5/8-11	1.250
HCI080	5/8-18	.938
HCI083	3/4-10	1.125
HCI086	3/4-16	1.125
HCI087	3/4-16	1.5
HCI089	7/8-9	1.312
HCI091	7/8-14	.875
HCI092	7/8-14	1.312
HCI095	1"-8	1.50
HCI096	1"-8	2.00
HCI110	1-1/8-7	1.688
HCI135	1-3/8-12	2.062
HCI139	1-1/2-6	1.50

**METRIC**

STOCK NO.	INTERNAL THREAD	PITCH	INSTALLED LENGTH
HCI319	M6	1.00	9.0
HCI325	M8	1.25	12.0
HCI331	M10	1.50	15.0
HCI340	M12	1.75	18.0
HCI446*	M14	1.25	3/4
HCI355	M16	2.00	24.0
HCI367	M20	2.50	30.0

\* SPARK PLUG

**INSERT KITS, ACCESSORIES AND NUTSERTS**

**PLUG TAP**



STOCK NO.	SIZE
HCT337	1/4-20
HCT339	5/16-18
HCT341	3/8-16
HCT345	1/2-13
HCT349	5/8-11

**INSTALLATION TOOL  
THREADED MANDREL TYPE**



STOCK NO.	SIZE
HCT505	1/4-20
HCT506	5/16-18
HCT507	3/8-16
HCT509	1/2-13

**MASTER THREAD REPAIR KIT**



A QUANTITY OF COARSE THREAD SIZES FROM 1/4-20 THROUGH 12-13. INCLUDES ONE TAP FOR EACH SIZE, AND ONE INSTALLATION TOOL FOR EACH SIZE. STURDY PLASTIC CASE.

STOCK NO. HCK002

**M14 SPARK PLUG KIT**



THE FIRST CHOICE OF PROFESSIONAL MECHANICS AND ENGINE REBUILDERS FOR SPARK PLUG PORT REPAIR. KIT CONTAINS A PILOTTED TAP (NO DRILLING NECESSARY), AN INSTALLATION TOOL AND A QUANTITY OF INSERTS WITH SEVERAL INSERT LENGTHS. RUGGED PLASTIC STORAGE CASE.

STOCK NO. HCK001

CUSTOMER SATISFACTION  
IS THE KEY TO OUR SUCCESS

**THREAD REPAIR KITS**



EACH KIT INCLUDES 3 LENGTHS OF ASSORTED INSERTS FOR MULTIPLE APPLICATIONS, HELI-COIL TAP, INSTALLATION TOOL, DRILL BIT AND TANG REMOVAL TOOL. RUGGED PLASTIC STORAGE CASE.

**USS COARSE THREAD**

STOCK NO.	SIZE
HCK106	1/4-20
HCK107	5/16-18
HCK108	3/8-16
HCK109	7/16-14
HCK110	1/2-13
HCK111	9/16-12
HCK112	5/8-11
HCK113	3/4-10
HCK114	7/8-9
HCK115	1"-8

**THREAD REPAIR KITS**

EACH KIT INCLUDES INSERTS, HIGH-SPEED TAP AND TANG BREAK-OFF/INSERTION TOOL.

**MACHINE SCREW THREAD**

STOCK NO.	SIZE
HCK102	6-32
HCK103	8-32
HCK104	10-24
HCK121	10-32
HCK105	12-24

**SAE FINE THREAD**

STOCK NO.	SIZE
HCK122	1/4-28
HCK123	5/16-24
HCK124	3/8-24
HCK125	7/16-20
HCK126	1/2-20
HCK127	9/16-18
HCK128	5/8-18
HCK129	3/4-16

**METRIC**

STOCK NO.	SIZE
HCK203	M5 x 0.80
HCK204	M6 x 1.00
HCK207	M7 x 1.00
HCK206	M8 x 1.25
HCK207	M9 x 1.25
HCK208	M10 x 1.50
HCK219	M10 x 1.00
HCK220	M10 x 1.25
HCK210	M12 x 1.75
HCK224	M12 x 1.50
HCK223	M12 x 1.25
HCK211	M14 x 2.00
HCK212	M16 x 2.00
HCK226	M16 x 1.50
HCK214	M20 x 2.50
HCK215	M24 x 3.00

**NUTSERTS**

**KNURLED THREADED INSERTS**



REGULAR DUTY

HEAVY DUTY

CREATE STRONG, PERMANENT STEEL THREADS IN BLIND, BURIED AND THROUGH HOLES (IN THIN METAL). THE NUTSERT IS HELD SECURELY BY AN INSTALLATION TOOL AND IS PLACED INTO A PREPARED HOLE. AS THE TOOL IS TIGHTENED WITH A WRENCH, THE THREADED PORTION IS PULLED UNTIL THE FASTENER'S WALL COLLAPSES RADIALLY OUTWARD, CLINCHING IT TIGHT AGAINST THE METAL. THE NUTSERT IS NOW READY TO RECEIVE A BOLT OR SCREW.

**REGULAR DUTY**

**HEAVY DUTY**

STOCK NO.	SIZE	STOCK NO.	SIZE
TNATS2832	8-32	TNALS4420165	1/4-20
TNATS21024	10-24	TNALS4524150	5/16-24
TNATS21032	10-32		
TNATS2420	1/4-20		
AV10279	1/4-28		
TNATS2518	5/16-18		
TNATS2616	3/8-16		

**NUTSERT PLACING TOOL**



AN INEXPENSIVE TOOL THAT IS IDEAL FOR APPLICATIONS SUCH AS FIELD REPAIR AND PROTOTYPE WORK.

**STOCK NO. SIZE**

TNAAT916632	6-32
TNAAT916832	8-32
TNAAT9161024	10-24
TNAAT9161032	10-32
TNAAT916420	1/4-20
TNAAT916518	5/16-18
TNAAT916616	3/8-16

**STEEL KLIK THREAD-SERT KIT**



THIS THREADED INSERT INSTALLATION KIT INCLUDES THE THREAD-SETTER TOOL, MANDRELS AND NOSE PIECES, WRENCH AND 62 ASSORTED STEEL KLIK THREAD-SERTS WHICH INCLUDES: 6-32, 8-32, 10-24, 10-32, 1/4-20, 5/16-18, 3/8-16.

STOCK NO.

MAR39214

**ANCHORS & ACCESSORIES**

**WEDGE ANCHORS**  
("T-STUDS")



THE WEDGE ANCHOR IS USED FOR H. D. FASTENING APPLICATIONS. THE ANCHOR AND THE HOLE DIAMETER ARE THE SAME. THE THREE PROTRUDING PRONGS GRIP THE INTERIOR OF THE HOLE, REDUCING THE LIKELIHOOD OF THE ANCHOR "SPINNING". THE WEDGE IS USED IN A VARIETY OF STRUCTURAL APPLICATIONS, INCLUDING FASTENING EQUIPMENT OR MATERIALS TO CONCRETE.

STOCK NO.	SIZE	BOX QTY.
UNTS14134	1/4 x 1-3/4	100
UNTS14214	1/4 x 2-1/4	100
UNTS14314	1/4 x 3-1/4	100
UNTS38214	3/8 x 2-1/4	100
UNTS38234	3/8 x 2-3/4	100
UNTS383	3/8 x 3"	100
UNTS38334	3/8 x 3-3/4	100
UNTS385	3/8 x 5"	50
UNTS12234	1/2 x 2-3/4	50
UNTS12334	1/2 x 3-3/4	50
UNTS12414	1/2 x 4-1/4	25
UNTS12512	1/2 x 5-1/2	25
UNTS127	1/2 x 7"	25
UNTS58312	5/8 x 3-1/2	25
UNTS58412	5/8 x 4-1/2	25
UNTS585	5/8 x 5"	25
UNTS586	5/8 x 6"	25
UNTS587	5/8 x 7"	25
UNTS58812	5/8 x 8-1/2	25
UNTS34414	3/4 x 4-1/4	20
UNTS34434	3/4 x 4-3/4	20
UNTS34512	3/4 x 5-1/2	20
UNTS34614	3/4 x 6-1/4	10
UNTS347	3/4 x 7"	10
UNTS34812	3/4 x 8-1/2	10
UNTS3410	3/4 x 10"	10
UNTS3412	3/4 x 12"	10
UNTS786	7/8 x 6"	5
UNTS788	7/8 x 8"	5
UNTS7810	7/8 x 10"	5
UNTS16	1" x 6"	5
UNTS19	1" x 9"	5
UNTS112	1" x 12"	5
UNTS1149	1-1/4 x 9"	5
UNTS11412	1-1/4 x 12"	5

**STAINLESS STEEL WEDGE ANCHORS**



STOCK NO.	SIZE	BOX QTY.
UNTS14134SS	1/4 x 1-3/4	100
UNTS14214SS	1/4 x 2-1/4	100
UNTS14314SS	1/4 x 3-1/4	100
UNTS38214SS	3/8 x 2-1/4	100
UNTS38234SS	3/8 x 2-3/4	100
UNTS38334SS	3/8 x 3-3/4	100
UNTS12234SS	1/2 x 2-3/4	50
UNTS12334SS	1/2 x 3-3/4	50
UNTS12414SS	1/2 x 4-1/4	25
UNTS12512SS	1/2 x 5-1/2	25
UNTS127SS	1/2 x 7"	25
UNTS587SS	5/8 x 7"	25
UNTS34414SS	3/4 x 4-1/4	20
UNTS34434SS	3/4 x 4-3/4	20
UNTS34512SS	3/4 x 5-1/2	20
UNTS347SS	3/4 x 7"	10

ADDITIONAL SIZES FOR ITEMS ON THIS PAGE AVAILABLE UPON REQUEST

**HEX HEAD SLEEVE ANCHORS**  
("T-BOLTS")

SLEEVE ANCHORS ARE DEPENDABLE FOR USE IN BRICK, CINDER BLOCK, THIN WALL, MARBLE, AND CONCRETE. ONE BENEFIT IS THAT THE BASE MATERIAL DOESN'T HAVE TO BE SOLID. THE SLEEVE ANCHOR'S DIAMETER AND THE HOLE SIZE ARE THE SAME. AN ADDED BENEFIT IS THE ABILITY TO REMOVE THIS ANCHOR AFTER INSTALLATION.



STOCK NO.	SIZE	BOX QTY.
UN2513	1/4 x 1-3/8	100
UN2522	1/4 x 2-1/4	100
UN3114	5/16 x 1-1/2	100
UN3124	5/16 x 2-1/2	100
UN3717	3/8 x 1-7/8	50
UN3730	3/8 x 3"	25
UN3740	3/8 x 4"	25
UN5022	1/2 x 2-1/4	25
UN5026	1/2 x 3"	25
UN5040	1/2 x 4"	25
UN5060	1/2 x 6"	25
UN6230	5/8 x 3"	25
USASH5842	5/8 x 4-1/4	20
USASH5860	5/8 x 6"	10
UN7524	3/4 x 2-1/2	10
UN7542	3/4 x 4-1/4	10
UN7562	3/4 x 6-1/4	10

**FLAT HEAD SLEEVE ANCHORS**



STOCK NO.	SIZE	BOX QTY.
UN2513F	1/4 x 1-3/8	100
UN2520F	1/4 x 2"	100
UN2530F	1/4 x 3"	100
UN3726F	3/8 x 2-3/4	50

**TITEN HEAVY DUTY ANCHOR**



THE TITEN HD IS A PATENTED, HIGH STRENGTH THREADED ANCHOR FOR CONCRETE AND MASONRY. THE SELF-UNDERCUTTING, NON-EXPANSION CHARACTERISTICS MAKES IT THE IDEAL ANCHOR FOR STRUCTURAL APPLICATIONS EVEN AT MINIMUM EDGE DISTANCES AND UNDER REDUCED SPACING CONDITIONS. RECOMMENDED FOR PERMANENT DRY INTERIOR NON-CORROSIVE APPLICATIONS, OR TEMPORARY OUTDOOR APPLICATIONS.

STOCK NO.	SIZE	BOX QTY.
SST0001	3/8 x 3"	50
SST0002	3/8 x 4"	50
SST0003	3/8 x 5"	50
SST0004	3/8 x 6"	50
SST0005	1/2 x 3"	25
SST0006	1/2 x 4"	20
SST0007	1/2 x 5"	20
SST0008	1/2 x 6"	20
SST0009	1/2 x 6-1/2	20
SST0010	1/2 x 8"	20
-	1/2 x 12"	20
-	1/2 x 13"	20
-	1/2 x 14"	20
-	1/2 x 15"	20
SST0015	5/8 x 4"	10
SST0016	5/8 x 5"	10
SST0017	5/8 x 6"	10
SST0018	5/8 x 6-1/2	10
SST0019	5/8 x 8"	10
SST0020	3/4 x 4"	10
SST0021	3/4 x 5"	5
SST0022	3/4 x 6"	5
SST0023	3/4 x 7"	5

**FORWAY ANCHORS**



HANDLES MEDIUM TO HEAVY LOADS. CAN BE USED IN DEAD, VARIABLE, OR VIBRATORY CONDITIONS IN ALL TYPES OF SOLID OR HOLLOW MASONRY MATERIALS. FOUR-WAY EXPANSION ASSURES POSITIVE ANCHORING EVEN UNDER ADVERSE CONDITIONS.

STOCK NO.	SIZE	DRILL HOLE	BOX QTY.
USE1104	1/4-20	1/2"	100
USE1105	5/16-18	9/16"	100
USE1106	3/8-16	11/16"	50
USE1108	1/2-13	7/8"	50
USE1110	5/8-11	1-1/8	50

**DROP-IN ANCHORS**



THE DROP-IN ANCHOR IS USED IN MEDIUM- TO HEAVY-DUTY APPLICATIONS IN SOLID MEDIA SUCH AS CONCRETE AND STONE. A FLUSH, FEMALE ANCHOR, THE DROP-IN HOUSES AN INTERNAL PLUG WHICH IS HELD SECURELY IN PLACE EVEN WHEN USED IN AN OVERHEAD APPLICATION. USING THE SETTING TOOL , THE PLUG IS DRIVEN TO EXACTLY THE RIGHT DEPTH, CAUSING THE ANCHOR TO EXPAND. DROP-INS ARE FREQUENTLY USED FOR OVER-HEAD APPLICATIONS

STOCK NO.	SIZE	DRILL SIZE	BOX QTY.
UNTD14	1/4-20	3/8	100
UNTD38	3/8-16	1/2	50
UNTD12	1/2-13	5/8	50
UNTD58	5/8-11	7/8	25
UNTD34	3/4-10	1"	25

**DROP-IN SETTING TOOL**



STOCK NO.	SIZE
UNST140	1/4
UNST380	3/8
UNST120	1/2
UNST580	5/8
UNST340	3/4

**LAG SHIELDS**



LAG SHIELDS ARE DESIGNED FOR LIGHT TO MEDIUM DUTY FASTENING IN CONCRETE, MORTAR JOINT, MASONRY AND BRICK. THE LAG SHIELD IS RUSTPROOF, AND IS USED WITH A LAG SCREW TO PROVIDE A DEPENDABLE ANCHOR. IN HARD MASONRY, THE SHORT LAG SHIELD MAY BE USED TO MINIMIZE DRILLING TIME. IN SOFTER MASONRY, THE LONG LAG SHIELD WILL DEVELOP SUPERIOR HOLDING STRENGTH.

STOCK NO.	SIZE	TYPE	BOX QTY.
UN1052	1/4"	SHORT	50
UN1056	1/4"	LONG	50
UN1053	5/16"	SHORT	50
UN1057	5/16"	LONG	50
UN1054	3/8"	SHORT	50
UN1058	3/8"	LONG	50
UN1055	1/2"	SHORT	25
UN1059	1/2"	LONG	25

**ANCHORS & ACCESSORIES**

**SINGLE EXPANSION SHIELDS**



THE RUST PROOF, ZINC ALLOY SINGLE EXPANSION ANCHOR IS USED WITH MACHINE SCREWS OR MACHINE BOLTS IN CONCRETE, BRICK OR STONE. THE SCREW OR BOLT CAN BE REMOVED FROM THE ANCHOR, IF NECESSARY, AND REPLACED, WITHOUT MATERIALLY EFFECTING THE HOLDING POWER OF THE ANCHOR.

STOCK NO.	SIZE	HOLE	BOX QTY.
USASE14	1/4 x 1-5/16	1/2	100
USASE56	5/16 x 1-1/2	5/8	50
USASE38	3/8 x 1-1/2	5/8	50
USASE12	1/2 x 2"	7/8	50
-	5/8 x 2-5/8	1"	-
-	3/4 x 2-3/4	1-1/4	-

**DOUBLE EXPANSION ANCHORS**



THE DOUBLE EXPANSION ANCHOR IS MANUFACTURED OF RUSTPROOF ZINC ALLOY, AND IS USED WITH MACHINE SCREWS OR MACHINE BOLTS. AS THE "DOUBLE" SETS, THE TWO OPPOSING WEDGES PULL TOWARDS EACH OTHER, EXPANDING THE FULL LENGTH OF THE ANCHOR BODY.

STOCK NO.	SIZE	HOLE	BOX QTY.
-	1/4 x 1"	1/2	-
USADE56	5/16 x 1-1/2	5/8	50
USADE38	3/8 x 1-1/2	5/8	50
-	1/2 x 2"	7/8	-
-	5/8 x 2-5/8	1"	-
-	3/4 x 2-7/8	1-1/4	-

**MACHINE SCREW ANCHORS**



THIS CAULKING TYPE MACHINE SCREW ANCHOR FEATURES A ZINC ALLOY CONE WITH A LEAD RING. WHEN SET IT PROVIDES A QUICK FIXING IN CONCRETE, STONE, BRICK, ETC.

STOCK NO.	SIZE	BOX QTY.
UN151	10-24	100
UN252	1/4-20	100
UN353	5/16-18	100

**ADDITIONAL SIZES AVAILABLE UPON REQUEST**

**NAIL-IN ANCHORS  
METAL**



THE METAL NAIL-IN ANCHOR IS RUSTPROOF AND DESIGNED TO VIRTUALLY ELIMINATE EMBRITTLEMENT WHICH FREQUENTLY OCCURS IN LOWER GRADES OF ZINC ALLOY. GOOD FOR APPLICATIONS IN CONCRETE, BRICK, BLOCK OR STONE. NAIL-INS HAVE A MUSHROOM HEAD AND ARE RELATIVELY TAMPER PROOF.

STOCK NO.	SIZE	BOX QTY.
UN4103	1/4 x 1"	100
UN4104	1/4 x 1-1/4	100
UN4105	1/4 x 1-1/2	100
UN4106	1/4 x 2"	100

**NYLON  
(MUSHROOMHEAD)**

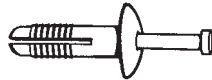

THE NYLON NAIL ANCHOR IS MADE OF VIRGIN NYLON, WHICH REMAINS FLEXIBLE AND RESISTANT TO DRYING AND EMBRITTLEMENT. THE NAIL IS ZINC PLATED STEEL, PARTIALLY THREADED WITH A SLOTTED HEAD TO FACILITATE REMOVAL, SHOULD IT BE NECESSARY ONCE THE ANCHOR HAS BEEN INSTALLED. THE NYLON NAIL ANCHOR IS USED FOR LIGHT DUTY FASTENING IN CONCRETE, BLOCK, BRICK, PLASTIC, WALLBOARD, SHEET METAL, WOOD, PLASTER, GLASS, SLATE, MARBLE, TILE, ETC.

STOCK NO.	SIZE	BOX QTY.
USE4460	3/16 x 3/4	100
ITM809NAOM81	1/4 x 1"	100
ITM809NAOM85	1/4 x 1-1/2	100
ITM809NAOM82	1/4 x 2"	100
ITM809NAOM83	1/4 x 3"	100

**ADDITIONAL SIZES AVAILABLE UPON REQUEST**

BILL SAT AT THE LOCAL BAR, BRAGGING ABOUT HIS ATHLETIC PROWESS. NONE OF THE REGULARS CHALLENGED HIM, BUT A VISITOR PIPED UP, "I'LL BET YOU 50 BUCKS THAT I CAN PUSH SOMETHING IN A WHEELBARROW FOR ONE BLOCK AND YOU CAN'T WHEEL IT BACK."  
BILL LOOKED OVER AT THE SKINNY STRANGER AND DECIDED IT WASN'T MUCH OF A CHALLENGE. "I'LL TAKE YOU ON," HE SAID.  
"THE TWO MEN AND A NUMBER OF REGULARS BORROWED A WHEELBARROW AND TOOK IT TO THE CORNER. "NOW, LET'S SEE WHAT YOU'RE MADE OF," TAUNTED BILL.  
"OKAY," SAID THE CHALLENGER. "GET IN."

**PLASTIC ANCHORS  
CONE TYPE**



USED PRIMARILY FOR LIGHT DUTY FASTENING IN CONCRETE, BRICK, MASONRY OR DRYWALL, THE CONICAL ANCHOR'S RIDGED BODY HELPS ELIMINATE SPINNING WHILE THE SCREW IS BEING INSERTED.

STOCK NO.	SIZE	BOX QTY.
UN6810	6-8 x 7/8	100
UN6815	8-10 x 7/8	100
UN6820	10-12 x 1"	100
UN6860	14-16 x 1-3/8	100

**POLY-TOGGLE**

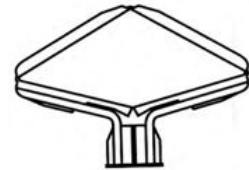

PRIMARILY USED FOR HOLLOW WALLS AND WALLBOARD, THE ANCHOR FOLDS DOWN FOR EASY INSTALLATION, AND THE SHARP RIBS ON THE WINGS PREVENT THE TOGGLE FROM PULLING OUT OR SPINNING WHILE BEING SET, THE REVERSE ACTION OF THE WINGS LOCKS THE ANCHOR INTO PLACE FOR A SECURE FITTING. THE SCREW MAY BE REMOVED AND THE ANCHOR REMAINS IN PLACE FOR SUBSEQUENT USE.

STOCK NO.	SIZE	TYPE	BOX QTY.
RA2303	3/8	SHORT	100
RA2304	1/2	MEDIUM	100
RA2305	5/8	LONG	100

**T-PLUG (FLUTED)**



THE ORIGINAL PLASTIC ANCHOR, THIS STRAIGHT, FLUTED PLUG WORKS IN A VARIETY OF SOLID MATERIALS SUCH AS CONCRETE, BRICK AND STONE. EASY TO INSTALL, IT IS A FLUSH MOUNT ANCHOR WITH COLOR CODED SIZES FOR EASY IDENTIFICATION. NON-CORROSIVE FOR DURABILITY AND STRENGTH IN LIGHT DUTY APPLICATIONS. VINYL PLASTIC PLUGS CAN BE USED WITH A WIDE VARIETY OF SCREWS.

STOCK NO.	SIZE	BOX QTY.
UN2006	1/4 x 1-1/4	100
UN2010	5/16 x 1-1/2	100

**ADDITIONAL SIZES AVAILABLE UPON REQUEST**

### ANCHORS & ACCESSORIES

#### HANGER MATE THREADED ROD ANCHORING SYSTEM

HANGER MATE ANCHORS ACCEPT 1/4-20 AND 3/8-16 ROD FOR ATTACHMENT TO WOOD, MASONRY OR STEEL

FOR WOOD

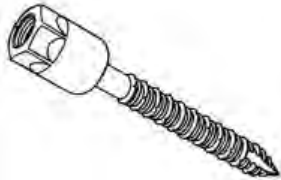

STOCK NO.	ROD SIZE	SHANK	HOLE SIZE REQUIRED
HMEZG315	1/4-20	5/16 X 2-1/4	NONE
HMEZG650	3/8-16	5/16 X 2-1/4	NONE

FOR CONCRETE

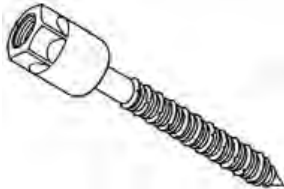

STOCK NO.	ROD SIZE	SHANK	HOLE SIZE REQUIRED
HMEZG365	1/4-20	5/16 X 2-1/4	1/4
HMEZG730	3/8-16	5/16 X 2-1/4	1/4

ADDITIONAL STYLES AND SIZES AVAILABLE UPON REQUEST

THREE MEN DIED AND WENT TO HEAVEN. UPON THEIR ARRIVAL, ST. PETER ASKED THE FIRST IF HE HAD BEEN FAITHFUL TO HIS WIFE. THE MAN ADMITTED TO TWO AFFAIRS DURING HIS MARRIAGE. ST. PETER TOLD HIM THAT HE COULD RECEIVE ONLY A COMPACT CAR TO DRIVE IN HEAVEN.

THEN ST. PETER ASKED THE SECOND MAN IF HE HAD BEEN FAITHFUL TO HIS WIFE, AND THE MAN ADMITTED TO ONE AFFAIR. ST. PETER TOLD HIM HE WOULD BE GIVEN A MIDSIZE CAR TO DRIVE.

THE THIRD MAN WAS ASKED ABOUT HIS FAITHFULNESS, AND HE TOLD ST. PETER HE HAD BEEN TRUE TO HIS WIFE UNTIL THE DAY HE DIED. ST. PETER PRAISED HIM AND GAVE HIM A LUXURY CAR.

A WEEK LATER THE THREE MEN WERE DRIVING AROUND, AND THEY ALL STOPPED AT A RED LIGHT. THE MEN IN THE COMPACT AND MIDSIZE CARS TURNED TO SEE THE MAN IN THE LUXURY CAR CRYING. THEY ASKED HIM WHAT COULD POSSIBLY BE THE MATTER -- AFTER ALL, HE WAS DRIVING A LUXURY CAR.

"I PASSED MY WIFE," HE TOLD THEM. "SHE WAS ON A SKATEBOARD."

#### HANGER MATE INSTALLATION TOOLS AND DRILL BITS

FOR WOOD

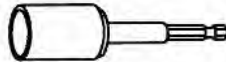

DRIVE SOCKET  
STOCK NO. HMEZE215

FOR CONCRETE

USE WITH DRILLS WITH STANDARD CHUCK

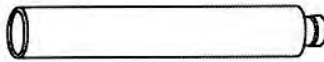

DRILL SLEEVE  
STOCK NO. HMEZE220



DRILL BIT ADAPTOR KIT  
STOCK NO. HMEZE240

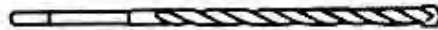

1/4" TANGED MASONRY BIT  
STOCK NO. HMEZE340

USE WITH DRILLS SDS HAMMER DRILL

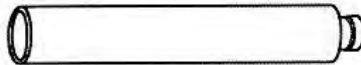

DRILL SLEEVE  
STOCK NO. HMEZE220



1/4" SDS / HEX BIT  
STOCK NO. HMEZE350

ADDITIONAL STYLES AND SIZES AVAILABLE UPON REQUEST

**IF YOU DON'T SEE SOMETHING  
HERE YOU NEED,  
GIVE US A CALL.  
WE WILL DO OUR BEST  
TO FIND IT  
FOR YOU.**



SPACE RESERVED FOR FUTURE ANCHOR ITEMS



**ANCHORS & ACCESSORIES**

**PLASTIC ANCHOR KITS**



INCLUDES 100 3/16" CONE TYPE ANCHORS, 100 #8 SCREWS, AND 1 (ONE) 3/16" DRILL BIT.  
**STOCK NO. USAPAK610**

INCLUDES 100 1/4" CONE TYPE ANCHORS, 100 #10 SCREWS, AND 1 (ONE) 1/4" DRILL BIT.  
**STOCK NO. USAPAK1012**

INCLUDES 50 5/16" CONE TYPE ANCHORS, 50 #14 SCREWS, AND 1 (ONE) 5/16" DRILL BIT.  
**STOCK NO. USAPAK1416**

**TURBO ANCHORS  
HOLLOW WALL ANCHORS**



THIS "EZ STYLE" ANCHOR IS TODAY'S SOLUTION TO ANCHORING IN DRYWALL. SIMPLY SCREW THE JET PLUG INTO THE WALL UNTIL FLUSH WITH SURFACE AND ATTACH ITEMS TO BE FASTENED WITH A SCREW. BOX QUANTITY 100.

**STOCK NO. RA2346**

**TURBO ANCHOR KIT**

INCLUDES 50 TURBO ANCHORS, 50 8 x 1-1/4" SCREWS, AND 1 (ONE) SETTING TOOL.

**STOCK NO. USE85601001**

**ZINC WALLBOARD ANCHOR KIT**



KITS MADE IN THE USA. IMPACT RESISTANT HANGABLE BOX. HIGH QUALITY MASONRY DRILL BIT FOR PROPER INSTALLATION. HIGH QUALITY SCREWS MATCH ANCHOR SIZE. KIT INCLUDES 50 LARGE ZINC ANCHORS, 50 8 x 1" COMBO SCREWS, AND 1 (ONE) NO. 2 PHILLIPS BIT.

**STOCK NO. USE8571100**

**TOGGLE HEADS**



STOCK NO.	SIZE	BOX QTY.
UN5010	1/8"	100
UN5020	3/16"	100
UN5030	1/4"	50
UN5045	5/16"	50
UN5055	3/8"	25
UN5065	1/2"	25

WORDS ARE LIKE DIAMONDS. POLISH THEM TOO MUCH, AND ALL YOU GET ARE PEBBLES.  
--BRYCE CORTENAY

**TOGGLE BOLTS**



STOCK NO.	SIZE	TYPE	BOX QTY.
UN5031	1/8 x 3"	RND.	100
UN5033	1/8 x 3"	MSH.	100
UN5041	1/8 x 4"	RND.	100
UN5131	3/16 x 3"	RND.	50
UN5133	3/16 x 3"	MSH.	100
UN5141	3/16 x 4"	RND.	50
UN5143	3/16 x 4"	MSH.	100
UN5151	3/16 x 5"	RND.	50
UN5161	3/16 x 6"	RND.	50
UN5231	1/4 x 3"	RND.	50
UN5233	1/4 x 3"	MSH.	50
UN5241	1/4 x 4"	RND.	50
UN5243	1/4 x 4"	MSH.	50
UN5251	1/4 x 5"	RND.	50
UN5261	1/4 x 6"	RND.	50
UN5331	5/16 x 3"	RND.	25
UN5341	5/16 x 4"	RND.	25
UN5351	5/16 x 5"	RND.	25
UN5361	5/16 x 6"	RND.	25
UN5441	3/8 x 4"	RND.	25
UN5451	3/8 x 5"	RND.	25
UN5461	3/8 x 6"	RND.	25
UN5541	1/2 x 4"	RND.	25

**EPOXY ANCHORS**



BE SAFE AND SURE WITH THESE ANCHORING CAPSULES. EXACT, PRE-MEASURED AMOUNTS OF AGGREGATE, RESIN, AND CATALYST ARE ENCASED WITHIN GLASS CAPSULES. THE CONTENTS ARE PROPERLY MIXED WHEN THE GLASS CAPSULE IS BROKEN WITH A STUD.

STOCK NO.	SIZE
UNTB38	3/8"
UNTB12	1/2"
UNTB58	5/8"
UNTB34	3/4"

**CHAMFERED STUDS  
(THREADED RODS)**

STOCK NO. SIZE



UNTB38	3/8 x 5"
UNTB12	1/2 x 6-1/2"
UNTB58	5/8 x 7-1/2"
UNTB34	3/4 x 9-3/4"

**ROD DRIVERS**



STOCK NO.	SIZE
USATRD38	3/8"
USATRD12	1/2"
USATRD58	5/8"
USATRD34	3/4"

**ULTRABOND CHEMICAL ANCHOR  
CARTRIDGE**



FOR CONCRETE, LIGHTWEIGHT AND AERATED CONCRETE, GROUT-FILLED CONCRETE BLOCK, HOLLOW CONCRETE BLOCK (CMU), SOLID AND HOLLOW BRICK, STONE. USES STANDARD CAULKING GUN.

**STOCK NO. USAEZ101**

**REPLACEMENT TIPS**



**STOCK NO. USAT58CK**

**ROCKITE  
FOR ANCHORING AND PATCHING**

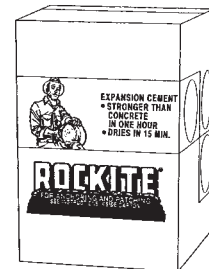

50 LB. BOX

ROCKITE IS AN EXPANDING, FAST-SETTING, POURABLE, HYDRAULIC TYPE CEMENT MORE THAN TWICE THE STRENGTH OF FULLY-CURED AND CONVENTIONAL CONCRETE. WHEN MIXED WITH WATER TO POURABLE CONSISTENCY, IT FLOWS AND SEEPS INTO PLACE AS THOUGH IT WERE MOLTEN LAVA. IT TAKES AN INITIAL SET WITHIN 15 MINUTES. WITHIN ONE HOUR IT DEVELOPS A COMPRESSION STRENGTH OF 4500 LBS. PER SQUARE INCH. ITS ADHESION IS DUE TO EXPANSION AND WHEN FULLY SET, IT GRIPS METAL TO CONCRETE PERMANENTLY.

**STOCK NO. ROC3**

**QUALITY PRODUCTS,  
FAIR AND COMPETITIVE  
PRICES, AND  
EXCELLENT  
SERVICE IS OUR  
REPUTATION**

**ANCHORS & ACCESSORIES**

**CONCRETE SCREWS**



EACH BOX CONTAINS 1 (ONE) CARBIDE TIPPED DRILL BIT. SOLD BY THE BOX ONLY.

**HEX HEAD**

STOCK NO.	SIZE	BOX QTY.
AAHX3114	3/16 x 1-1/4	100
AAHX3134	3/16 x 1-3/4	100
AAHX3214	3/16 x 2-1/4	100
AAHX3234	3/16 x 2-3/4	100
AAHX3314	3/16 x 3-1/4	100
AAHX114	1/4 x 1-1/4	100
AAHX134	1/4 x 1-3/4	100
AAHX214	1/4 x 2-1/4	100
AAHX234	1/4 x 2-3/4	100
AAHX314	1/4 x 3-1/4	100
AAHX400	1/4 x 4"	100
AAHX500	1/4 x 5"	100
AAHX600	1/4 x 6"	100

**PHILLIPS FLAT HEAD**

STOCK NO.	SIZE	BOX QTY.
AAFH3114	3/16 x 1-1/4	100
AAFH3134	3/16 x 1-3/4	100
AAFH3214	3/16 x 2-1/4	100
AAFH3234	3/16 x 2-3/4	100
AAFH3314	3/16 x 3-1/4	100
AAFH3400	3/16 x 4"	100
AAFH114	1/4 x 1-1/4	100
AAFH134	1/4 x 1-3/4	100
AAFH214	1/4 x 2-1/4	100
AAFH234	1/4 x 2-3/4	100
AAFH314	1/4 x 3-1/4	100
AAFH400	1/4 x 4"	100
AAFH500	1/4 x 5"	100
AAFH600	1/4 x 6"	100

**STAINLESS STEEL HEX HEAD**

410 STAINLESS STEEL. SILVER STALGARD COATING

STOCK NO.	SIZE	BOX QTY.
AAHX114SS	1/4 x 1-1/4	100
AAHX134SS	1/4 x 1-3/4	100
AAHX214SS	1/4 x 2-1/4	100
AAHX234SS	1/4 x 2-3/4	100

**CONCRETE SCREW DRILL BITS**



BLACK OXIDE FINISH AND HIGH QUALITY CARBIDE TIP.

STOCK NO.	SIZE
AAS532	5/32 x 3-1/2
AAM532	5/32 x 4-1/2
AAL532	5/32 x 5-1/2
AAS316	3/16 x 3-1/2
AAM316	3/16 x 4-1/2
AAL316	3/16 x 5-1/2
AAXL316	3/16 x 6-1/2
AAXXL316	3/16 x 7-1/2

**CONCRETE SCREW INSTALLATION KIT**



INCLUDES DRIVE TUBE, 1/4" DRIVE NUT SETTER, 5/16" DRIVE NUT SETTER, HOLDER FOR PHILLIPS BITS, DRILL HOLDER, L-HEX KEY, #2 AND #3 PHILLIPS BITS. HEAVY-DUTY PLASTIC CASE.

**STOCK NO. AADRT**

**POWER LOADS**  
(100 PER BOX ON ALL VARIETIES)



**.22 CALIBER SHORT CRIMPED**

STOCK NO.	TYPE
UNI22C1	LIGHT
UNI22C2	MEDIUM
UNI22C3	STRONG
UNI22C4	EXTRA-STRONG

**.25 CALIBER PLASTIC (10 SHOT) STRIP**



STOCK NO.	TYPE
UNI25CS3	LIGHT
UNI25CS4	MEDIUM
UNI25CS5	HEAVY

**.27 CALIBER PLASTIC (10 SHOT) STRIP**



STOCK NO.	TYPE
UNI27CS3	LIGHT
UNI27CS4	MEDIUM
UNI27CS5	HEAVY
UNI27CS6	EXTRA-HEAVY

**.27 CALIBER LONG CRIMPED**



STOCK NO.	TYPE
UNI27CL3	LIGHT
UNI27CL4	MEDIUM
UNI27CL5	HEAVY
UNI27CL6	EXTRA-HEAVY

**IF YOU DON'T SEE SOMETHING HERE YOU NEED.**

**GIVE US A CALL**

**WE WILL DO OUR BEST TO FIND IT FOR YOU.**

**DRIVE PINS**



9/64 - .300 HEAD DIAMETER  
3/8" HEAD DIAMETER  
(\*with washer)

STOCK NO.	SIZE	BOX QTY.
UNIDW100*	9/64 x 1"	100
UNIDW125*	9/64 x 1-1/4	100
UNIDW150*	9/64 x 1-1/2	100
UNIDW200*	9/64 x 2"	100
UNIDW250*	9/64 x 2-1/2	100
UNIDW300*	9/64 x 3"	100
UNID58	9/64 x 1/2	100
UNID63	9/64 x 5/8	100
UNID75	9/64 x 3/4	100
UNID100	9/64 x 1"	100
UNID125	9/64 x 1-1/4	100
UNID150	9/64 x 1-1/2	100
UNID175	9/64 x 1-3/4	100
UNID1875PP*	9/64 x 1-7/8	100
UNID200	9/64 x 2"	100
UNID250	9/64 x 2-1/2	100
UNID300	9/64 x 3"	100
UNID31250	3/8 x 1-1/4	100
UNID32000	3/8 x 2"	100
UNID33000	3/8 x 3"	100

\*THESE PINS USED FOR METAL NOT CONCRETE.

**HAMMER DRIVE PIN**



STOCK NO.	SIZE	BOX QTY.
UNIP75H	1/4 x 3/4	100
UNIP250H	1/4 x 2-1/2	100
UNIP300H	1/4 x 3"	100

**METRIC DRIVE PINS**

STOCK NO.	SIZE	BOX QTY.
UNIPH75	4mm x 3/4	100
UNIPH100	4mm x 1"	100
UNIPH150	4mm x 1-1/2	100
UNIPH200	4mm x 2"	100
UNIPH250	4mm x 2-1/2	100
UNIPH300	4mm x 3"	100
UNIDH63K*	8mm x 5/8	100
UNIDH75K*	8mm x 3/4	100
UNIDH100	8mm x 1"	100
UNIDH125	8mm x 1-1/4	100
UNIDH150	8mm x 1-1/2	100
UNIDH200	8mm x 2"	100
UNIDH250	8mm x 2-1/2	100
UNIDH300	8mm x 3"	100

\*KNURLED SHANK

SOMETIMES THE BEST HELPING HAND YOU CAN GET IS A GOOD, FIRM PUSH.

--JOANN THOMAS





**ABRASIVES**



**GRINDING WHEELS**



**BENCH GRINDING WHEELS**



EVERY WHEEL IS BALANCED AND SPEED TESTED TO INSURE FAST CUTTING. TYPE 1 WHEELS AVAILABLE IN ALUMINUM OXIDE AND SILICON CARBIDE. ALL WHEELS SUPPLIED WITH NESTED BUSHINGS.

**SPECIFICATIONS FOR BENCH GRINDING WHEELS**

**ALUMINUM OXIDE**

- A24** EXTRA COARSE - ROUGHING
- A36** COARSE ROUGHING (METAL)
- A60** MEDIUM - GENERAL GRINDING
- A80** FINE FINISHING

**STOCK NO.**                      **SIZE**                      **SPEC.**

<b>AB053</b>	6" x 1/2 x 1"	A36
<b>AB054</b>	6" x 1/2 x 1"	A60
<b>AB055</b>	6" x 1/2 x 1"	A80
<b>AB056</b>	6" x 3/4 x 1"	A36
<b>AB057</b>	6" x 3/4 x 1"	A60
<b>AB058</b>	6" x 3/4 x 1"	A80
<b>AB059</b>	6" x 1" x 1"	A36
<b>AB060</b>	6" x 1" x 1"	A60
<b>AB061</b>	6" x 1" x 1"	A80
<b>AB062</b>	7" x 3/4 x 1"	A36
<b>063</b>	7" x 3/4 x 1"	A60
<b>AB065</b>	7" x 1" x 1"	A36
<b>AB066</b>	7" x 1" x 1"	A60
<b>AB067</b>	7" x 1" x 1"	A80
<b>AB068</b>	8" x 3/4 x 1-1/4	A36
<b>AB069</b>	8" x 3/4 x 1-1/4	A60
<b>AB070</b>	8" x 3/4 x 1-1/4	A80
<b>AB071</b>	8" x 1" x 1-1/4	A36
<b>AB072</b>	8" x 1" x 1-1/4	A60
<b>AB073</b>	8" x 1" x 1-1/4	A80
<b>AB074</b>	10" x 1" x 1-1/4	A24
<b>AB075</b>	10" x 1" x 1-1/4	A36
<b>AB076</b>	10" x 1" x 1-1/4	A60
<b>083</b>	12" x 2" x 1-1/2	A24
<b>AB084</b>	12" x 2" x 1-1/2	A36
<b>AB085</b>	12" x 2" x 1-1/2	A60

**SILICON CARBIDE**

- GC60** COARSE - ROUGHING
- GC80** MEDIUM - GENERAL GRINDING (GLASS)
- GC120** FINE FINISHING (FIBERGLASS)

**STOCK NO.**                      **SIZE**                      **SPEC.**

<b>AB093</b>	6" x 3/4 x 1"	GC60
<b>AB094</b>	6" x 3/4 x 1"	GC80
<b>AB095</b>	6" x 3/4 x 1"	GC120
<b>AB096</b>	6" x 1" x 1"	GC60
<b>AB097</b>	6" x 1" x 1"	GC80
<b>AB098</b>	6" x 1" x 1"	GC120
<b>AB108</b>	8" x 1" x 1-1/4	GC60
<b>AB109</b>	8" x 1" x 1-1/4	GC80
<b>AB111</b>	10" x 1" x 1-1/4	GC60
<b>117</b>	12" x 2" x 1-1/4	GC60

**OTHER SIZES AVAILABLE FOR ITEMS ON THIS PAGE BY REQUEST. SURFACE GRIND WHEELS ARE FEATURED ON THE NEXT PAGE.**

**TYPE 28**

STOCK NO.	SIZE	SPEC.	BOX QTY.
<b>ABA1237</b>	4-1/2 x 1/4 x 7/8	A30S	25
<b>AB168</b>	7" x 1/4 x 7/8	A24/30T	25
<b>AB174</b>	7" x 1/4 x 5/8-11	A24/30T	10
<b>AB182</b>	9" x 1/4 x 7/8	A24/30T	25
<b>AB188</b>	9" x 1/4 x 5/8-11	A24/30T	10

**FLEXON PREMIUM ZIRCONIUM GRINDING WHEELS**



**ZA20Q- FAST CUT (EVEN IN HARD ALLOYS)**

**TYPE 27**

STOCK NO.	SIZE	SPEC.	BOX QTY.
<b>ABA1244</b>	4-1/2 x 1/4 x 7/8	ZA20Q	10
<b>ABA5444H</b>	7" x 1/4 x 5/8-11	ZA20Q	10
<b>ABA8444H</b>	9" x 1/4 x 5/8-11	ZA20Q	10

**TYPE 28**

<b>ABA5404H</b>	7" x 1/4 x 5/8-11	ZA20Q	10
-----------------	-------------------	-------	----

**GRINDING WHEEL HUB ADAPTER KIT**

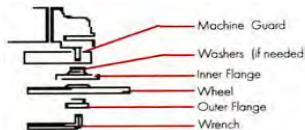

REUSABLE KIT INCLUDES ALL PARTS NECESSARY TO PROPERLY MOUNT 7" AND 9" WHEELS (TYPES 27 AND 28) ON GRINDERS WITH 5/8-11 SPINDLES.

**STOCK NO. ABCP50**

**FLARING CUPSTONES**



TYPE 11 NON-REINFORCED FLARING CUPSTONES ARE USED FOR GRINDING OF CASTINGS AND WELDS. CONSTRUCTED OF TOUGH ALUMINUM OXIDE AND/OR SILICON CARBIDE GRAIN, RESIN BONDED WITH A FULL STEEL BACK.

**SPECIFICATIONS FOR FLARING CUPSTONES**

- A16QB** - METAL GENERAL PURPOSE
- C16PB** - CONCRETE

STOCK NO.	SIZE	SPEC.	RPM
<b>AB195</b>	5" x 2" x 5/8-11	A16QB	7260
<b>AB196</b>	6" x 2" x 5/8-11	A16QB	6050
<b>AB197</b>	6" x 2" x 5/8-11	C16PB	6050

**SPECIFICATIONS FOR RIGHT ANGLE GRINDER WHEELS**

<b>A30S</b> <b>A24N</b>	AGGRESSIVE CUTTING AND GRINDING WITH EXCELLENT LIFE. PERFORMS WELL IN A BROAD RANGE OF METALS (CARBON AND STAINLESS STEELS).
<b>C24/30P</b>	FOR CUTOFF APPLICATIONS IN CONCRETE AND MASONRY.
<b>A24/30T</b>	SMOOTH CUTTING AND GRINDING WITH MAXIMUM LIFE FOR AN ALUMINUM OXIDE WHEEL. THE STANDARD FOR GRINDING.
<b>A30Q</b>	SPECIALLY FORMULATED FOR CUTTING STAINLESS STEELS AND OTHER ALLOY METALS. SMOOTH AND FAST CUTTING.
<b>A24ALU</b>	NON-LOADING IN ALUMINUM AND OTHER NON-FERROUS METALS.
<b>A30R</b>	DESIGNED FOR PIPELINE AND LIGHT GRINDING. FOR PRESSURE VESSEL AND PIPE FABRICATION.

**TYPE 27**

STOCK NO.	SIZE	SPEC.	BOX QTY.
<b>AB148</b>	3" x 1/4 x 3/8	A30S	25
<b>ABA0390</b>	4" x 1/4 x 3/8	A30S	25
<b>MET616745000</b>	4" x 1/4 x 5/8	A24N	25
<b>AB154</b>	4" x 1/4 x 5/8	A30S	25
<b>AB155</b>	4-1/2 x 1/8 x 7/8	A30S	25
<b>ABA1231</b>	4-1/2 x 1/4 x 7/8	A30Q	25
<b>ABA1236H</b>	4-1/2 x 1/4 x 5/8-11	A30S	25
<b>ABA1257</b>	4-1/2 x 1/4 x 7/8	C24/30P	25
<b>MET1672642</b>	4-1/2 x 1/4 x 7/8	A24N	25
<b>AB157</b>	4-1/2 x 3/16 x 7/8	A30S	25
<b>AB158</b>	4-1/2 x 1/4 x 7/8	A30S	25
<b>AB159</b>	4-1/2 x 1/4 x 7/8	A24ALU	25
<b>AB160</b>	5" x 1/4 x 7/8	A30S	25
<b>AB161</b>	5" x 1/4 x 7/8	A30Q	25
<b>ABA3236</b>	6" x 1/4 x 7/8	A30S	25
<b>AB164</b>	7" x 1/8 x 5/8-11	A30R	10
<b>AB167</b>	7" x 1/4 x 7/8	A24/30T	25
<b>AB173</b>	7" x 1/4 x 5/8-11	A24ALU	10
<b>AB176</b>	7" x 1/4 x 5/8-11	A24/30T	10
<b>ABA5331H</b>	7" x 1/4 x 5/8-11	A30Q	10
<b>ABA5446H</b>	7" x 1/4 x 5/8-11	C24/30P	10
<b>ABA7280H</b>	9" x 1/8 x 5/8-11	A30R	10
<b>AB181</b>	9" x 1/4 x 7/8	A24/30T	25
<b>AB187</b>	9" x 1/4 x 5/8-11	A24/30T	10
<b>AB189</b>	9" x 1/4 x 5/8-11	A30S	10

**FLEXOVIT** **UNITED ABRASIVES, INC.**

**ABRASIVES**

**STANDARD ABRASIVES** **FLEXOVIT**

**SURFACE GRINDING WHEELS**



PRECISION-BALANCED. PREMIUM RUBY/WHITE ALUMINUM OXIDE MIXTURE WHEELS. RECOMMENDED FOR ALL-PURPOSE GRINDING OF TOOL STEELS AND CARBON STEELS. J HARDNESS.

STOCK NO.	SIZE	GRIT
AB127	7" x 1/2 x 1-1/4	46
AB129	7" x 1/2 x 1-1/4	60

ADDITIONAL SIZES AVAILABLE UPON REQUEST

**DESMOND**



**DRESSERS AND CUTTERS**

STOCK NO.	DRESSER NO.	DIA.	FACE
DES11210	0	UP TO 10"	2"
DES11310	1	10" TO 16"	3"
DES11510	2	16" TO 36"	3-1/2"



STOCK NO.	CUTTER NO.	DIA.	HOLE	FACE
DES11220	0	1-1/4"	1/4"	.426"
DES11320	1	1-1/2"	1/2"	.432"
DES11520	2	2-3/8"	19/32"	.830"

**CUT-OFF/GRINDING WHEELS**

DIE GRINDER OR ANGLE GRINDER WHEELS  
STOCK NO. SIZE BOX QTY.



ABF0105	2" x .035 x 1/4	100
ABF0269	2-1/2 x 3/8 x 3/8	15
AB213	3" x .035 x 1/4	50
AB214	3" x .035 x 3/8	50
ABF0320	3" x 1/16 x 3/8	50
ABF0340	3" x 1/8 x 3/8	25
AB216	3" x 1/2 x 3/8	10

CONTINUED NEXT COLUMN

STOCK NO.	SIZE	BOX QTY.
ABF0420	4" x 1/16 x 3/8	50
AB300	4" x 1/8 x 3/8	25
FA1F31	4" x .035 x 5/8	50
FA04	4-1/2 x .040 x 7/8	100
AB220	4-1/2 x 3/32 x 7/8	25
FA3B13	6" x 1/16 x 1/2	25
ABF1707	6" x .045 x 7/8	25
ABA3175	6" x 3/32 x 7/8	25

**TYPE 27 ANGLE GRINDER CUT-OFF WHEELS**



STOCK NO.	SIZE	BOX QTY.
ABA0481	4-1/2 x .045 x 7/8	25
UA22047	6" x .045 x 7/8	50
<b>ALUMINUM CUTTING</b>		
UA22345	4-1/2 x .045 x 7/8	50

**ARBORS FOR SMALL DIA. CUT-OFF WHEELS**



GENERAL PURPOSE FOR HEAVIER WHEELS

2-PIECE BLACK OXIDE. SLOTTED HEAD ON LOCKING SCREW. NO WASHER NEEDED.

STOCK NO. AB998 (1/4 SHANK x 1/4 HOLE)  
STOCK NO. AB999 (1/4 SHANK x 3/8 HOLE)

HOLDS UP TO 1/2" THICK WHEELS (3" DIA.). 1/4 SHANK x 3/8 HOLE. BLACK OXIDE.

STOCK NO. AB1000

**CIRCULAR SAW CUT-OFF WHEELS**



FOR CUTTING STEEL, CONCRETE, BRICK AND MASONRY PRODUCTS.

**SPECIFICATIONS FOR CIRCULAR SAW WHEELS**

A36TB38	METAL GENERAL PURPOSE		
C30UB64	CONCRETE AND MASONRY		
STOCK NO.	SIZE	SPEC.	BOX QTY.
AB224	7" x 3/32 x (DIA) 5/8+D	A36TB38	25
AB223	7" x 1/8 x (DIA) 5/8+D	C30UB64	25
AB225	8" x 3/32 x (DIA) 5/8+D	A36TB38	25
AB226	8" x 1/8 x (DIA) 5/8+D	C30UB64	25

**ROAD CONSTRUCTION CUT-OFF WHEELS**



**SPECIFICATIONS FOR ROAD CONSTR. WHEELS**

C20SB	CURED CONCRETE		
C16UB	ASPHALT AND GREEN CONCRETE		
STOCK NO.	SIZE	SPEC.	BOX QTY.
AB250	14" x 3/16 x 1"	C20SB	10
ABL6017	14" x 3/16 x 1"	C16UB	10

**STATIONARY MACHINE (CHOP SAWS) CUT-OFF WHEELS**



**SPECIFICATIONS FOR STATIONARY MACHINE CUT-OFF WHEELS**

A30RB	METAL GENERAL PURPOSE		
A30SB	METAL LONG LIFE (FOR HIGHER HORSEPOWER MACHINES)		
STOCK NO.	SIZE	SPEC.	BOX QTY.
AB230	10" x 3/32 x 5/8	A30SB	10
AB2305	12" x 3/32 x 1"	A30RB	10
ABF4808	12" x 3/32 x 1"	A30SB	10
AB232	12" x 1/8 x 1"	A30SB	10
ABF5521	14" x 3/32 x 1"	A30RB	10
AB234	14" x 3/32 x 1"	A30SB	10
MET16338	14" x 3/32 x 1"	A30	10
ABF5836	14" x 1/8 x 1"	A30RB	10
ABF6521	16" x 3/32 x 1"	A30RB	10
ABF6861	16" x 5/32 x 1"	A30RB	10
AB238	20" x 3/16 x 1"	A30RB	10
ABF9300	22" x 3/16 x 1"	A30SB	10

**HIGH-SPEED PORTABLE GAS AND ELECTRIC SAW CUT-OFF WHEELS**



CONSTRUCTED OF QUALITY ALUMINUM OXIDE AND/OR SILICON CARBIDE GRAIN, WITH A UNIQUE WEAVE OF EXTRA HIGH TENSILE FIBERGLASS REINFORCING AND SPECIALLY FORMULATED RESIN BONDS.

**SPECIFICATIONS FOR PORTABLE GAS AND ELECTRIC SAW CUT-OFF WHEELS**

A24/30SB	HEAVY-DUTY METAL. EXCELLENT FOR CUTTING RE-BAR, PIPE AND STRUCTURAL PROFILES IN BOTH MILD AND STAINLESS STEELS.		
AC24SB	DUCTILE IRON, CAST IRON AND CONCRETE-LINED PIPE.		
C30UB	HEAVY-DUTY CONCRETE (CURED). BRICK, BLOCK, CLAY PIPE, PVC PIPE AND OTHER MASONRY ITEMS.		
C16UB	ASPHALT AND GREEN CONCRETE.		

STOCK NO.	SIZE	SPEC.	BOX QTY.
AB2315	12" x 1/8 x 20mm	A24/30SB	10
AB231	12" x 1/8 x 20mm	C30UB	10
ABL5017	12" x 1/8 x 20mm	AC24SB	10
ABL5330	12" x 5/32 x 20mm	C16UB	10
AB2316	12" x 1/8 x 7/8	C30UB	10
AB240	12" x 1/8 x 1"	A24/30SB	10
AB241	12" x 1/8 x 1"	AC24SB	10
AB242	12" x 1/8 x 1"	C30UB	10
ABL5334	12" x 5/32 x 1"	C16UB	10
AB246	14" x 1/8 x 20mm	A24/30SB	10
ABL5617	14" x 1/8 x 20mm	AC24SB	10
AB245	14" x 1/8 x 20mm	C30UB	10
ABL5619	14" x 1/8 x 1"	AC24SB	10
ABF5687	14" x 1/8 x 1"	A24/30SB	10
ABL5727	14" x 1/8 x 1"	C30UB	10
ABL5712	14" x 5/32 x 1"	C16UB	10

**ABRASIVES**

**DIAMOND BLADES**



<b>STOCK NO.</b>	<b>SIZE</b>
<b>DMB003</b>	4" x .080 x 7/8-5/8
<b>DMB009</b>	6" x .080 x 5/8-DM
<b>DMB010</b>	8" x .090 x 5/8-DM

**SGL. ROW CUP WHEEL**  
(RIGHT ANGLE GRINDER)  
**DMB006** 4" x 7/8-5/8

**TUCK POINT BLADE FOR MORTAR JOINTS**  
**DMB004** 4-1/2 x .250 x 7/8-5/8

**WALK BEHIND**  
(ASPHALT & GREEN CONCRETE)  
**DMB017** 12" x .125 x 1"  
**DMB020** 14" x .125 x 1" (DRY CUT)

**HAND-HELD CUT-OFF SAWS**  
**DMB016** 12" x .110 x 1"  
**DMB020** 14" x .125 x 1"

**DTEC MULTI-PURPOSE BLADES**  
WILL CUT THRU CONCRETE, STEEL, STONE AND BRICK. WET OR DRY CUTTING.  
**DMB101** 4-1/2 x 7/8  
**DMB102** 5" x 7/8  
**DMB103** 6" x 7/8

**BUFFING WHEELS**



Loose Type      Sewed Type

**SEWED:** FIRM, FOR BUFFING AND CUTTING.  
**LOOSE:** FINE, FOR HIGH LUSTER/SATIN FINISH.

**STOCK NO. DTMG95602** (6" SEWED)  
**STOCK NO. DTMG95601** (6" LOOSE)  
**STOCK NO. DTMG95802** (8" SEWED)  
**STOCK NO. DTMG95801** (8" LOOSE)  
**STOCK NO. GR47330** (BUFFING COMPOUND)

**ABRASIVE STONES**



A/O INDIA STONES FOR SMOOTHING AND SHARPENING. AVAILABLE IN VARIOUS SHAPES AND SINGLE OR COMBINATION GRITS. COMBINATION HAS FINE GRIT ON ONE SIDE, AND COARSE ON THE OTHER.

CONTINUED NEXT COLUMN

**BENCH STONES**

4" x 1" x 1/2"  
**STOCK NO. GR10456** (FINE )  
**STOCK NO. GR10461** (MED.)

6" x 2" x 1"  
**STOCK NO. GR10451** (COMBINATION)  
**STOCK NO. GR10457** (FINE GRIT)  
**STOCK NO. GR10462** (MEDIUM GRIT)

**SLIPS**

**STOCK NO. GR10472** (4" x 1/2 FLAT MED. GRIT)

**STOCK NO. GR10478** (4" x 1" KNIFE FINE GRIT)  
**STOCK NO. GR10479** (4" x 1" KNIFE MED. GRIT)

**STOCK NO. GR10486** (4" x 1" RND. EDGE FINE)

**STOCK NO. GR10489** (4" x 1/4 SQUARE FINE)  
**STOCK NO. GR10490** (4" x 1/4 SQUARE MED.)

**STOCK NO. GR10497** (4" x 1/2 SQUARE MED.)  
**STOCK NO. GR10498** (4" x 1/2 SQUARE COARSE)

**STOCK NO. GR10506** (4" x 1/4 TRIANG. FINE)  
**STOCK NO. GR10507** (4" x 1/4 TRIANG. MED.)

**STOCK NO. GR10512** (4" x 1/2 TRIANG. MED.)

**ADDITIONAL GRITS AND SIZES**  
**AVAILABLE UPON REQUEST**



**MOUNTED POINTS**



PFERD MOUNTED POINTS ARE OF VITRIFIED BOND AND OFFERED IN THE FOLLOWING GRADE OF HARDNESS:

**O=MEDIUM, ALUMINUM OXIDE**

IF SIZES, GRADES OR GRITS ARE REQUIRED WHICH DIFFER FROM THOSE IN THE STANDARD PROGRAM, THESE CAN BE SUPPLIED ON REQUEST.

**MOUNTED POINTS**  
**1/4" DIAMETER SHANK**  
**SERIES A**

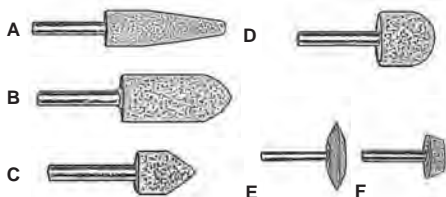

<b>STOCK NO.</b>	<b>PFERD NO.</b>	<b>DIA. x LENGTH</b>	<b>GRIT/ HARDNESS</b>	<b>STYLE</b>
<b>P31001</b>	A1-O 30	3/4 x 2-1/2	30/O	A
<b>P31061</b>	A11-O 30	7/8 x 2"	30/O	B
<b>P31091</b>	A14-O 30	11/16 x 1-1/4	30/O	C
<b>P31111</b>	A21-O 30	1" x 1"	30/O	D
<b>P31211</b>	A35-O 30	1" x 3/8	30/O	F
<b>P31224</b>	A36-O 60	1-5/8 x 3/8	60/O	E

**MOUNTED POINTS**  
**1/8" DIAMETER SHANK**  
**SERIES B**

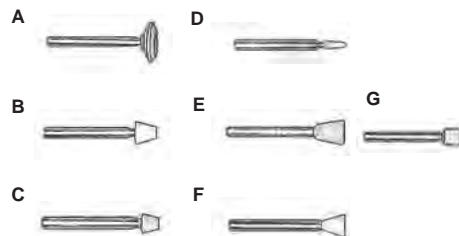

<b>STOCK NO.</b>	<b>PFERD NO.</b>	<b>DIA. x LENGTH</b>	<b>GRIT/ HARDNESS</b>	<b>STYLE</b>
<b>P32518</b>	B72-O 100	1/2 x 1/8	100/O	A
<b>P32608</b>	B92-O 100	1/4 x 1/4	100/O	B
<b>P32618</b>	B93-O 100	3/16 x 3/16	100/O	C
<b>P32668</b>	B98-O 100	3/32 x 1/4	100/O	D
<b>P32705</b>	B104-O 80	5/16 x 3/8	80/O	E
<b>P32718</b>	B105-O 100	1/4 x 1/4	100/O	F
<b>P32758</b>	B113-O 100	1/4 x 1/4	100/O	G

**ADDITIONAL ITEMS**  
**AVAILABLE UPON REQUEST**

**MOUNTED POINTS**  
**1/8" AND 1/4" DIAMETER SHANK**  
**SERIES W**  
(CYLINDRICAL MOUNTED POINTS)



<b>STOCK NO.</b>	<b>PFERD NO.</b>	<b>DIA. x LENGTH</b>	<b>GRIT/ SHANK HARDNESS</b>
<b>P33209</b>	W154-O 100	3/16 x 1/2	100/O 1/8
<b>P33329</b>	W162-O 100	1/4 x 3/8	100/O 1/8
<b>P33338</b>	W163-O 60	1/4 x 1/2	60/O 1/8
<b>P33536</b>	W176-O 80	3/8 x 1/2	80/O 1/8
<b>P33551</b>	W177-O 80	3/8 x 3/4	80/O 1/4
<b>P33650</b>	W184-O 80	1/2 x 3/8	80/O 1/8
<b>P33710</b>	W188-O 46	1/2 x 1-1/2	46/O 1/4
<b>P33842</b>	W197-O 30	5/8 x 2"	30/O 1/4
<b>P33848</b>	W197-O 60	5/8 x 2"	60/O 1/4
<b>P33962</b>	W205-O 30	3/4 x 1"	30/O 1/4
<b>P33968</b>	W205-O 60	3/4 x 1"	60/O 1/4
<b>P34202</b>	W221-O 30	1" x 1-1/2	60/O 1/4



### ABRASIVES



#### CONES AND PLUGS

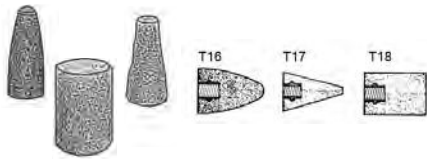

STOCK NO.	TYPE	DIA.	LGTH.	BORE	MAX RPM
UA25000	16 CONE	1-1/4"	3"	3/8-24	29,000
UA25005	16 CONE	2"	3"	3/8-24	18,100
UA25006	16 CONE	2"	3"	5/8-11	18,100
UA25104	17 CONE	1-1/2"	3"	5/8-11	24,100
UA25106	17 CONE	2"	3"	5/8-11	18,100
UA25204	18 PLUG	1-1/2"	3"	5/8-11	24,100
UA25206	18 PLUG	2"	3"	5/8-11	18,100

OTHER SIZES/TYPES AVAILABLE PER REQUEST

#### RESIN FIBER DISCS



STOCK NO.	DIA.	ARBOR HOLE	GRIT	BOX QTY.
AB0001	4"	5/8	24	25
AB0002	4"	5/8	36	25
AB0004	4"	5/8	60	25
AB0007	4"	5/8	120	25
AB0009	4-1/2"	7/8	16	25
AB001	4-1/2"	7/8	24	25
AB002	4-1/2"	7/8	36	25
AB004	4-1/2"	7/8	50	25
AB005	4-1/2"	7/8	60	25
AB006	4-1/2"	7/8	80	25
SA530006	4-1/2"	7/8	80	25
AB007	4-1/2"	7/8	100	25
AB008	4-1/2"	7/8	120	25
AB010	5"	7/8	24	25
AB011	5"	7/8	36	25
AB012	5"	7/8	50	25
AB014	5"	7/8	80	25
AB015	5"	7/8	100	25
AB016	5"	7/8	120	25
AB017	7"	7/8	16	25
AB018	7"	7/8	24	25
AB019	7"	7/8	36	25
AB020	7"	7/8	50	25
AB021	7"	7/8	60	25
AB022	7"	7/8	80	25
AB023	7"	7/8	100	25
AB024	7"	7/8	120	25
AB026	9"	7/8	24	25
AB027	9"	7/8	36	25
AB028	9"	7/8	60	25
AB029	9"	7/8	80	25

#### ECONOMY GRADE R. F. DISCS

STOCK NO.	DIA.	ARBOR HOLE	GRIT	BOX QTY.
AB001S	4-1/2"	7/8	24	25
AB002S	4-1/2"	7/8	36	25
AB005S	4-1/2"	7/8	60	25

#### ZIRCONIUM RESIN FIBER DISCS



ZIRCONIA ALUMINUM OXIDE DISCS PROVIDE COOL CUTTING AND LONGEST LIFE IN ALL TYPES OF METALS. CONTROLLED GRAIN FRACTURE AND GRINDING AIDS COMBINE TO PROVIDE THE MOST COST-EFFECTIVE FIBER DISC CHOICE.

STOCK NO.	DIA.	ARBOR HOLE	GRIT	BOX QTY.
AB0321	4-1/2"	7/8	ZA24	25
AB0325	4-1/2"	7/8	ZA80	25
AB035	7"	7/8	ZA36	25
AB038	7"	7/8	ZA80	25

#### BACKING PADS AND ACCESSORIES



SPIRALCOOL BACK-UP PADS ARE REINFORCED RUBBER-BONDED TO ALUMINUM HUB. FRESH, FIRM BACK-UP PADS CAN EXTEND DISC LIFE UP TO 50%!

STOCK NO.	DIA.	x	CENTER NUT
ABS5110	4-1/2"	x	5/8-11
ABR500R	5"	x	5/8-11
ABR700R	7"	NUT NOT INCLUDED	
ABR900R	9"	NUT NOT INCLUDED	



STOCK NO.	DESCRIPTION	FOR USE ON
AB046	5/8-11 NUT	4-1/2 & 5" PADS
AB047	1/2-13 NUT	4-1/2 & 5" PADS
AB048	14mm x 1.5 NUT	4-1/2 & 5" PADS
AB049	5/8-11 NUT	7" & 9" PADS
AB050	SPANNER WRENCH	CENTER NUTS

#### NYLON BACKING PADS



STOCK NO.	DIA.	FITS BACKING NUT
MET23279	4-1/2"	M14
MET23283	4-1/2"	5/8-11
MET23278	5"	M14
MET23281	7"	5/8-11

#### PREMIUM FLAP DISCS



FOR FLAT AND LIGHT CONTOUR GRINDING ON MILD STEEL, CAST IRON, STAINLESS STEEL, ALUMINUM, PLASTICS AND SHEET METAL

STOCK NO.	DIA.	ARBOR HOLE	GRIT	BOX QTY.
<b>ZIRCONIUM TYPE 27 JUMBO</b>				
FLA712	4-1/2"	7/8	Z60	10
<b>ZIRCONIUM TYPE 29</b>				
FLA009	4-1/2"	7/8	Z40	10
FLA010	4-1/2"	7/8	Z60	10
FLA012	4-1/2"	7/8	Z120	10
FLA015	5"	7/8	Z40	10
FLA016	5"	7/8	Z60	10
FLA017	5"	7/8	Z80	10
FLA234	7"	5/8-11	AF60	10

#### ZIRCONIUM TYPE 29 JUMBO

FLA509	4-1/2"	7/8	Z40	10
FLA510	4-1/2"	7/8	Z60	10
FLA511	4-1/2"	7/8	Z80	10
FLA622	6"	7/8	Z60	10

#### ALUMINUM OXIDE TYPE 27

FLA406	4"	5/8	AF80	10
--------	----	-----	------	----

#### ALUMINUM OXIDE TYPE 29

FLA334	4-1/2"	5/8-11	AF60	10
--------	--------	--------	------	----

#### ABRASIVE SHEETS



#### PAPER BACKING SPECIFICATIONS

**"A" WEIGHT** LIGHT, TOUGH 40 LB. PAPER USED PRIMARILY WHERE FINE GRITS ARE REQUIRED.

**"C" WEIGHT** MEDIUM-LIGHT 70 LB. PAPER IDEALLY SUITED FOR CABINET WORK.

**"D" WEIGHT** MEDIUM-HEAVY 90 LB. PAPER (MEDIUM/COARSE GRITS).

#### WET-DRY SILICON CARBIDE SANDING SHEETS

9" x 11" WATERPROOF "A" WEIGHT PAPER FOR VERY FINE FINISHING AND SMOOTHING APPLICATIONS ON WOOD, METAL, LACQUERS, VARNISH AND ENAMEL.

STOCK NO.	GRIT	SHEETS/PACK
AP2007	220	50
AP2004	320	50
AP2002	400	50
AP2000	600	50

#### GARNET PAPER

9" x 11" ORANGE OPEN-COAT. REDUCED LOADING. FOR HAND SANDING OF MEDIUM TO SOFT WOODS.

STOCK NO.	GRIT/ WT.	SHEETS/PACK
SAN22	50 D	50
SAN23	60 D	50
SAN24	80 D	50
SAN25	100 C	50
SAN26	120 C	50
SAN32	180 A	50
SAN33	220 A	50



**ABRASIVES**



**ABRASIVE SHEETS  
(CONTINUED)**

**9" x 11" A/O CLOTH SHEETS**

INDUSTRIAL-QUALITY ALUMINUM OXIDE GRAIN. SUPERB FOR ANY TYPE METAL FABRICATION AND MACHINE SHOP USE. GLUE BONDED.

STOCK NO.	GRIT/ WT.	SHEETS/PACK
SAN02	36 X	25
SAN04	60 X	25
SAN05	80 J	25
SAN06	100J	50
SAN07	120J	50
SAN08	150J	50
SAN09	180J	50
SAN10	220J	50
SAN13	320J	50
-	400J	50

**9" x 11" EMERY CLOTH**

GOOD FOR LIGHT METAL CLEAN-UP, TO REMOVE RUST AND SCALE, AND FOR POLISHING OF NON-PLATED METALS. SILICON CARBIDE GRAIN.

STOCK NO.	GRIT	SHEETS/PACK
SAN16	FINE	50
SAN17	MEDIUM	50
SAN18	COARSE	50

**9" x 11" CROCUS CLOTH**

USED FOR FINE METAL POLISHING AND CORROSION REMOVAL.

**STOCK NO. SA999** (50 SHEETS PER PACK)

**9" x 11" SCREEN CLOTH**

CLOTH SCREEN WITH SILICON CARBIDE GRAIN. STRONG, LONG-LASTING AND NON-LOADING. USE ON FIBERGLASS, BODY FILLER, PAINT, CEMENT, CERAMIC, MARBLE AND METALS.

STOCK NO.	GRIT	SHEETS/PACK
UA84076	80	50
UA84078	120	50

ADDITIONAL SIZES AND GRITS AVAILABLE FOR ALL TYPES OF ABRASIVE SHEETS BY REQUEST

**PSA SANDING DISCS**



PRESSURE SENSITIVE ADHESIVE ON BACK PROVIDES A STRONG BOND, YET CAN BE EASILY REMOVED. CLEANER OPERATIONS. A/O RESIN BONDED. FOR

APPLICATIONS REQUIRING SPEEDY POLISHING, BLENDING, FLASH REMOVAL AND DEBURRING. 12" DIAMETER.

STOCK NO.	GRIT	SHEETS/PACK
SA210	24	10
SA211	36	10
SA212	50	10
SA213	60	10
SA214	80	10
SA215	100	10

**SHOP ROLLS**



A/O HANDY SHOP ROLLS ARE STANDARD FOR DEBURRING, CLEANING AND POLISHING METAL SURFACES. EXCELLENT FOR HARD FINISHING. 50 YARD ROLLS.

**RESIN BONDED**

EXCELLENT GRAIN ADHESION QUALITIES AND RESISTANCE TO PHYSICAL DETERIORATION AND MOISTURE. TOUGH AND DURABLE. DESIGNED TO WITHSTAND HEAT.

STOCK NO.	WIDTH	GRIT/WT.
GAR38154	1-1/2	80 J
GAR38158	1-1/2	180J
GAR38163	1-1/2	400J
GAR38201	2"	40 J
GAR38202	2"	50 J
GAR38203	2"	60 J
GAR38204	2"	80 J
GAR38205	2"	100J
GAR38206	2"	120J
GAR38207	2"	150J
GAR38208	2"	180J
GAR38209	2"	220J
GAR38210	2"	240J
GAR38212	2"	320J
GAR38213	2"	400J

**SANDING BELTS**



A/O GRAIN, RESIN BONDED CLOTH BELTS FOR BENCH AND PORTABLE POWER SANDERS.

**OPEN COAT BELTS**

OPEN COAT ABRASIVES LOAD LESS READILY. VERY EFFECTIVE ON OPERATIONS WHERE THE SANDED MATERIAL TENDS TO CLOG THE COATING (EXAMPLES: SOFT WOODS, PAINT AND VARNISH).

STOCK NO.	SIZE	GRIT/WT.	BOX QTY.
SB101	3" x 21"	50 X	10
SB112	3" x 21"	80 X	10
SB132	3" x 21"	120X	10
SB22	3" x 24"	50 X	10
SB23	3" x 24"	80 X	10
SB24	3" x 24"	120X	10
SB285	4" x 24"	60 X	10
SB29	4" x 24"	80 X	10
SB30	4" x 24"	100X	10
SB31	4" x 36"	80 X	10
SB38	6" x 48"	80 X	10
SB39	6" x 48"	100X	10

CONTINUED NEXT COLUMN

**CLOSED COAT BELTS**

GOOD FOR OPERATIONS WHERE A HIGH RATE OF STOCK REMOVAL AND A HEAVY WORKING PRESSURE ARE REQUIRED.

STOCK NO.	SIZE	GRIT/WT.	BOX QTY.
SB00312	1/2 x 24"	80 J	50
SB0035	1/2 x 30"	36 X	50
SB01	1" x 42"	40 X	50
SB02	1" x 42"	80 X	50
SB03	1" x 42"	100J	50
SB04	1" x 42"	220J	50
SB05	2" x 48"	60 X	10
SB06	2" x 48"	220X	10
SB07	2" x 90"	80 X	10
SB08	2" x 90"	120X	10
SB085	3" x 18"	80 X	10
SB086	3" x 18"	120X	10
SB09	3" x 21"	24 X	10
SB10	3" x 21"	40 X	10
SB11	3" x 21"	80 X	10
SB12	3" x 21"	100X	10
SB13	3" x 21"	120X	10
SB14	3" x 21"	180X	10
SB15	3" x 24"	24 X	10
SB151	3" x 24"	36 X	10
SB16	3" x 24"	40 X	10
SB17	3" x 24"	50 X	10
SB18	3" x 24"	60 X	10
SB19	3" x 24"	80 X	10
SB20	3" x 24"	100X	10
SB21	3" x 24"	120X	10
SB245	4" x 24"	36 X	10
SB25	4" x 24"	60 X	10
SB26	4" x 24"	80 X	10
SB27	4" x 24"	100X	10
SB28	4" x 24"	120X	10
SB318	4" x 36"	80 X	10
SB32	4" x 36"	180X	10
SB34	6" x 48"	36 X	10
SB35	6" x 48"	50 X	10
SB36	6" x 48"	60 X	10
SB37	6" x 48"	80 X	10
SB391	6" x 48"	120X	10
SB393	6" x 48"	180X	10
SB40	6" x 48"	220X	10
SB402	6" x 48"	320X	10

**PREMIUM PSA SANDING DISCS  
(FOR DUAL ACTION SANDERS)**

DURABLE OPEN COAT. ALUMINUM OXIDE GRAIN. STRONG BOND RESISTANT TO HEAT AND MOISTURE. LONG LIFE.

STOCK NO.	SIZE	GRIT	PCS./PACK
UA36620	6"	80	100
UA36622	6"	120	100
UA36624	6"	180	100
UA36625	6"	220	100

BE CAREFUL OF YOUR THOUGHTS; THEY MAY BECOME WORDS AT ANY MOMENT.

--IARA GASSEN

**SANDING BANDS & DRUMS**



RESIN BOND SPIRAL SANDING BANDS ARE HANDY FOR FINISHING CURVED OR CONTOURED AREAS AND OTHER HARD-TO-REACH PLACES. MADE TO VERY CLOSE TOLERANCES. DESIGNED TO PREVENT SKIPPING AND BUMPING. ALUMINUM OXIDE.

STOCK NO.	SIZE	GRIT
SA02264	1/2" x 1/2"	36 X
-	1/2" x 1/2"	50 X
-	1/2" x 1/2"	60 X
SA023	3/4" x 3/4"	36 X
SA0232	3/4" x 3/4"	60 X
SA0234	3/4" x 3/4"	100X
SA024	3/4" x 1"	80 X
SA025	1" x 1"	36 X
SA0255	1" x 1"	50 X
SA026	1" x 1"	60 X
SA0261	1" x 1"	80 X
SA027	1" x 1"	100X
SA0271	1" x 1"	120X
SA0272	1" x 1"	150X
-	1" x 1"	240X
SA028	1" x 1"	320X
SA029	1" x 2"	36 X
SA031	1" x 2"	80 X
SA032	1-1/2" x 1-1/2"	36 X
SA033	1-1/2" x 1-1/2"	60 X
SA034	1-1/2" x 1-1/2"	80 X
SA035	1-1/2" x 1-1/2"	100X
SA036	1-1/2" x 1-1/2"	120X
SA0365	1-1/2" x 1-1/2"	150X
SA037	1-1/2" x 1-1/2"	220X
SA0375	1-1/2" x 1-1/2"	240X
SA038	1-1/2" x 1-1/2"	320X
SA043	2" x 2"	36 X
SA044	2" x 2"	60 X
SA045	2" x 2"	80 X
SA046	2" x 2"	120X
SA056	3" x 3"	36 X

**RUBBER DRUMS**



STOCK NO.	SIZE	SHANK
SA078	1/2" x 1/2"	1/4
SA079	3/4" x 3/4"	1/4
SA080	1" x 1"	1/4
SA081	1-1/2" x 1-1/2"	1/4
SA0812	1" x 2"	1/4
SA082	2" x 2"	1/4
SA084	3" x 3"	3/8

ADDITIONAL SANDING BANDS, QUICK-CHANGE DISCS, FLAP WHEELS & ACCESSORIES AVAILABLE UPON REQUEST

**QUICK-CHANGE DISCS**



LAMINATED QUICK-CHANGE DISCS WITH PATENTED "TWIST-ON TWIST-OFF" ALL METAL LOCKING DEVICE. DISCS ARE SECURELY ANCHORED TO PADS. 2-PLY FLEXIBILITY FOR EXTREME CONTOURS, GOOD STOCK REMOVAL, BLENDING AND POLISHING. A/O GRAIN.

**MOUNTS**

**METAL NUT: (MN)** "TWIST-ON TWIST-OFF" ALL METAL LOCKING DEVICE FOR SECURE ANCHOR.

**PLASTIC LOCK-IT STUD: (PS)** COMPATIBLE WITH 3M ROLOC.

STOCK NO.	DIA.	GRIT	MOUNT	QTY.
-	1"	36	MN	100
-	1"	80	MN	100
-	1"	100	MN	100
SA522208	1"	120	MN	100
SA522209	1"	150	MN	100
SA522211	1"	240	MN	100
SA522303	1-1/2"	40	MN	100
SA000	2"	36	MN	100
SA592404	2"	50	PS	100
SA001	2"	50	MN	100
SA592405	2"	60	PS	100
SA592406	2"	80	PS	100
SA002	2"	80	MN	100
SA592407	2"	100	PS	100
SA592501	3"	24	PS	50
SA003	3"	36	MN	50
SA005	3"	50	MN	50
SA592504	3"	50	PS	50
SA006	3"	60	MN	50
SA592505	3"	60	PS	50
SA007	3"	80	MN	50
SA592506	3"	80	PS	50

THE FOLLOWING DISCS OFFER A STIFFER MORE DURABLE BACKING.

STOCK NO.	DIA.	GRIT	MOUNT	QTY.
SA599402	2"	36	PS	100
SA599404	2"	50	PS	100
SA599406	2"	80	PS	100
SA599502	3"	36	PS	50
SA599504	3"	50	PS	50

**RUBBER BACKING PADS FOR QUICK-CHANGE DISCS**



PROVIDE LONG-LASTING PERFORMANCE WITH IMPROVED BALANCE. 1/4" STEEL MANDREL. GENERAL PURPOSE MEDIUM RUBBER DENSITY. TYPES: STANDARD (METAL NUT) AND LOCK-IT(PLASTIC STUD).

STOCK NO.	PAD DIAMETER	TYPE
SA020	1"	STANDARD
SA021	2"	STANDARD
SA022	3"	STANDARD
SA546057	2"	LOCK-IT
SA546060	3"	LOCK-IT

**FLAP WHEELS**



DESIGNED FOR PERFECT BALANCE IN STATIONARY AND PORTABLE GRINDERS. FOR FAST POLISHING AND BLENDING SURFACE PREPARATION ON STEEL, ALUMINUM, RUBBER, WOOD AND PLASTICS. A/O RESIN BOND.

STOCK NO.	SIZE	GRIT
SA146	6" x 1"	40 X
SA149	6" x 1"	80 X
SA151	6" x 1-1/2"	80 X
SA160	6" x 2"	80 X
SA161	6" x 2"	120X

**FLAP WHEEL BUSHINGS**



STOCK NO.	SIZE
SA171	1" x 1/2"
SA172	1" x 5/8"
SA173	1" x 3/4"

**MINIATURE FLAP WHEELS**

PERMANENT 1/4-20 THREADED STEEL SHANK OR 1/4 STRAIGHT SHANK RUNS COMPLETELY THROUGH WHEEL FOR BETTER BALANCE.

STOCK NO.	SIZE	GRIT	SHANK
SA090	1" x 1/2"	80X	1/4-20
SA621108	1" x 1/2"	120X	1/4-20
WE30720*	1" x 1"	60X	1/4-STR.
SA094	1" x 1"	60X	1/4-STR.
SA095	1" x 1"	80X	1/4-20
SA096	1-1/2" x 1/2"	60X	1/4-20
SA097	1-1/2" x 1/2"	80X	1/4-20
SA099	1-1/2" x 1"	80X	1/4-20
SA100	2" x 1/2"	80X	1/4-20
SA101	2" x 1/2"	120X	1/4-20
SA103	2" x 1"	60X	1/4-20
SA613445	2" x 1"	60X	1/4-STR.
SA104	2" x 1"	80X	1/4-20
SA613446	2" x 1"	80X	1/4-STR.
SA108	2-1/2" x 1"	80X	1/4-20
P45422	2-1/2" x 1"	120X	1/4-20
SA110	3" x 1/2"	60X	1/4-20
SA111	3" x 1/2"	80X	1/4-20
SA1115	3" x 1"	60X	1/4-20
WE30727*	3" x 1"	80X	1/4-STR.
SA112	3" x 1"	80X	1/4-20
SA615446	3" x 1"	80X	1/4-STR.

\* ECONOMY GRADE

**1/4-20 FEMALE ADAPTERS FOR FLAP WHEELS**



CONVERTS 1/4-20 THREADED SHANK TO 1/4" STRAIGHT SHANK.

STOCK NO. CLE069	( x 1-3/4")
STOCK NO. CLE070	( x 4")
STOCK NO. CLE071	( x 6")



**ABRASIVES - SURFACE CONDITIONING**



**STRAIGHT CARTRIDGE ROLLS**



LONG LASTING RESIN BOND ROLLS. IDEAL FOR FLASH REMOVAL, POLISHING, REMOVING MACHINE TOOL MARKS AND EDGE BREAKING. 1/8 ARBOR HOLE.

STOCK NO.	SIZE	GRIT
SA709700	1/4 x 1-1/2	320X
SA704406	1/4 x 1-1/2	60 X
SA704551	5/16 x 1-1/2	60 X
SA713420	5/16 x 1-1/2	100X
SA703732	3/8 x 1-1/2	60 X
SA706044	3/8 x 1-1/2	100X
SA709187	1/2 x 1-1/2	60 X
SA708530	1/2 x 1-1/2	100X

ADDITIONAL CARTRIDGE ROLL SIZES, STYLES AND GRITS AVAILABLE UPON REQUEST.

**CARTRIDGE ROLL MANDREL**



1/8" PILOT DIAMETER. 1" PILOT LENGTH. 1/4" SHANK DIAMETER.

STOCK NO.	SIZE (OAL)
SA710190	2-3/4
SA7101904	4"
SA7101906	6"

**BUFF AND BLEND ROLL**



BUFF & BLEND ROLLS ARE USED WITH VIBRATORY, ORBITAL AND STRAIGHT-LINE SANDERS, TO PRODUCE MATTE AND SATIN FINISHES. ROLLS ARE ALSO CUT TO SIZE AND USED BY HAND OR TO FINISH A PART TURNING ON A LATHE OR SPINDLE. THE BUFF &

BLEND ROLL CAN BE USED FOR: DEBURRING, CLEANING, BLENDING AND FINISHING.

STOCK NO.	SIZE
SA830021	6" X 30' (VERY FINE)

OTHER GRADES AVAILABLE PER REQUEST.

**6" x 9" HAND PADS**



TOUGH, NON-WOVEN NYLON FIBER CONSTRUCTION. NON-METALLIC. NON-CONDUCTIVE. CAN BE USED DRY OR WET WITH WATER, POLISH OR SOLVENTS. SELF-DRESSING AND NON-CLOGGING. WASHABLE AND REUSABLE.

**BROWN- HEAVY-DUTY:**

DESIGNED TO LAST LONGER ON TOUGH, DEMANDING JOBS. PROVIDES THE MOST AGGRESSIVE FINISHING. IDEAL FOR WELD CLEANING, RUST OR OXIDE REMOVAL, BLENDING OR DEBURRING.  
**STOCK NO. SA073** (BOX QTY. 10)

**GREEN- GENERAL PURPOSE:**

MOST POPULAR FOR FINISHING AND GENERAL CLEANING. IDEAL FOR RUST REMOVAL AND SURFACE CONDITIONING, BLENDING, FINE BURR REMOVAL ON METAL PARTS AND FOR DEGREASING MACHINE PARTS.  
**STOCK NO. SA071** (BOX QTY. 20)

**MAROON- VERY FINE:**

IDEAL FOR BLENDING AND FINISHING STAINLESS STEEL, REMOVING RUST AND CORROSION, LIGHT DEBURRING, CLEANING & FINISHING AND REMOVING LIGHT OXIDATION & DISCOLORATION.  
**STOCK NO. SA070** (BOX QTY. 20)

**GRAY- ULTRA-FINE:**

IDEAL FOR FINAL SURFACE PREPARATION BEFORE PAINTING OR VARNISHING- EXCELLENT FOR LIGHT SCUFFING BETWEEN COATS. ALSO GOOD FOR HAND CLEANING PRINTED CIRCUIT BOARDS, AND FOR LIGHT CLEANING & FINISHING OF METAL, COMPOSITES AND WOOD SURFACES.  
**STOCK NO. SA072** (BOX QTY. 20)

**HAND PAD HOLDER**



**STOCK NO. SA827000**

**AH BRITE STRIP DISC**



**STOCK NO. SA843401**      **SIZE 4" X 1/4**

**STEEL WOOL**



16 UNIT SLEEVE. 12 SLEEVES PER CASE.

**GRADE 0000 - FINEST**

ULTRA-SMOOTH FINISH, FINAL HAND RUBBING APPLICATION.  
**STOCK NO. SW001**

**GRADE 000 - EXTRA FINE**

EXCELLENT FOR METAL POLISHING.  
**STOCK NO. SW002**

**GRADE 00 - FINE**

GOOD FOR CUTTING GLOSS FINISHES AND WOOD FLOORING PREPARATION.  
**STOCK NO. SW003**

**GRADE 0 - MEDIUM FINE**

GOOD FOR RUST REMOVAL & SURFACE CLEANING DUE TO OXIDATION. SCOURING POTS/PANS.  
**STOCK NO. SW004**

**GRADE 1 - MEDIUM**

GOOD WHITE SIDEWALL CLEANER. WOOD AND METAL PREP FOR PAINTING.  
**STOCK NO. SW005**

**GRADE 2 - MEDIUM COARSE**

ROUGH SURFACE CLEANING. MACHINERY & TOOL CLEAN-UP.  
**STOCK NO. SW006**

**GRADE 3 - COARSE**

HEAVY CLEAN-UP ON ROUGH SURFACES. GOOD FOR OLD PAINT REMOVAL.  
**STOCK NO. SW007**



FIVE POUND ROLLS OF GRADE 1 (MEDIUM) STEEL WOOL.

**STOCK NO. AFS5044**



## ABRASIVES - SURFACE CONDITIONING



### SURFACE CONDITIONING DISCS

USED FOR MATERIAL REMOVAL. IDEAL FOR FLAT AND CONTOUR SURFACES. APPLICATIONS INCLUDE: DEBURRING, BLENDING AND CLEANING.

#### TYPES

**COARSE: BROWN, HEAVY-DUTY.** REMOVES SURFACE COATINGS AND CONTAMINANTS, INCLUDING RUST.

**MEDIUM: MAROON, GENERAL PURPOSE.** REMOVES LIGHT RUST AND SURFACE COATINGS.

**VERY FINE: DARK BLUE, GENERAL DUTY .** REMOVES CORROSION, PAINTS AND COATINGS.

### SURFACE CONDITIONING DISCS

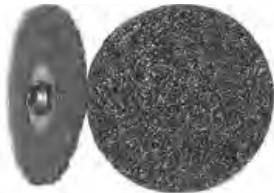

STOCK NO.	SIZE	TYPE	QTY.
SA840331	2"	COARSE	50
- 840333	2"	VERY FINE	-
SA840431	3"	COARSE	25
SA840432	3"	MEDIUM	25

### SURFACE CONDITIONING DISCS ROLON STYLE



STOCK NO.	SIZE	TYPE	QTY
SA840387	2"	COARSE	50
SA840388	2"	MEDIUM	50
SA840487	3"	COARSE	25
SA840488	3"	MEDIUM	25

### 3M BRISTLE DISC



IDEAL FOR SAFELY CLEANING AND STRIPPING PAINT AND A WIDE VARIETY OF OTHER SUBSTANCES OFF OF METAL. BENEFITS INCLUDE CONSISTENT WEAR, UNIFORM FINISH, AND LACK OF LOADING.

STOCK NO.	SIZE	TYPE	QTY
3MA18734	3"	COARSE-GREEN	10
3MA18736	3"	MEDIUM-YELLOW	10
3MA18737	3"	FINE-WHITE	10

### PLASTIC LOCK-IT STUD



COMPATIBLE WITH THREE M ROLOC

STOCK NO.	SIZE	ARBOR
SA546057	2"	1/4 SHANK
SA546060	3"	1/4 SHANK

### HOOK & LOOP DISCS



STOCK NO.	SIZE	TYPE	QTY.
- 842337	2"	COARSE	-
- 842338	2"	MEDIUM	-
SA842437	3"	COARSE	25
SA842438	3"	MEDIUM	25
UA77118	4-1/2	COARSE	10
UA77120	4-1/2	MEDIUM	10
- 845514	4-1/2	VERY FINE	-

### HOOK & LOOP PADS



VELCRO STYLE. THE "HOOKS" OF THE BACKING PAD LOCK INTO THE "LOOPS" OF THE DISC, PROVIDING FOR BOTH PROPER FASTENING AND A QUICK CHANGE.

STOCK NO.	SIZE	ARBOR
SA840020	2"	1/4 SHANK
SA840030	3"	1/4 SHANK

UA95159	4-1/2	5/8-11 NUT
---------	-------	------------

### METAL NUT BACK-UP PAD



"TWIST-ON TWIST-OFF"  
ALL METAL LOCKING  
DEVICE FOR SECURE  
ANCHOR.

STOCK NO.	SIZE	ARBOR
SA021	2"	1/4 SHANK
SA022	3"	1/4 SHANK

### BUFF AND BLEND DISCS

USED MORE AS A FINISHING/POLISHING DISC IN LIGHT DUTY WORK. APPLICATIONS INCLUDE: BLENDING, CLEANING, DEBURRING AND FINISHING.

#### TYPES

**COARSE: TAN, GENERAL PURPOSE.** FOR ALL MINOR APPLICATIONS

**MEDIUM: MAROON, MINOR DEBURRING** APPLICATIONS.

**FINE: MAROON, MINOR BLENDING** APPLICATIONS.

**VERY FINE: MAROON, MINOR FINISHING** APPLICATIONS.

### BUFF AND BLEND DISCS



STOCK NO.	SIZE	TYPE	QTY.
- 840311	2"	COARSE	-
SA840312	2"	MEDIUM	50
SA840313	2"	FINE	-
- 840315	2"	VERY FINE	-
- 840411	3"	COARSE	-
SA840412	3"	MEDIUM	25
SA840413	3"	FINE	25
SA840415	3"	VERY FINE	25

### BUFF AND BLEND DISCS ROLON STYLE



STOCK NO.	SIZE	TYPE	QTY.
SA810312	2"	MEDIUM	50
SA810412	3"	MEDIUM	25

*CALL YOUR  
ORDER FOR  
PROMPT,  
COURTEOUS  
ASSISTANCE.*





**HEAVY DUTY DRILLS / STRAIGHT SHANK**

**HIGH SPEED STEEL**  
JOBBER'S LENGTH 135° SPLIT POINT



STOCK NO.	DIAMETER (INCHES)	PACKAGE QUANTITY
VT110001	*1/64	12
VT110019	*1/32	12
VT110027	*3/64	12
VT110035	1/16	12
VT110043	5/64	12
VT110050	3/32	12
VT110068	7/64	12
VT110076	1/8	12
VT110084	9/64	12
VT110092	5/32	12
VT110100	11/64	12
VT110118	3/16	12
VT110126	13/64	12
VT110134	7/32	12
VT110142	15/64	12
VT110159	1/4	12
VT110167	17/64	12
VT110175	9/32	12
VT110183	19/64	6
VT110191	5/16	6
VT110209	21/64	6
VT110217	11/32	6
VT110225	23/64	6
VT110233	3/8	6
VT110241	25/64	6
VT110258	13/32	6
VT110266	27/64	6
VT110274	7/16	6
VT110282	29/64	6
VT110290	15/32	6
VT110308	31/64	6
VT110316	1/2	6

\*118 POINT

**HIGH SPEED STEEL**  
JOBBER'S LENGTH 118° SPLIT POINT



STOCK NO.	WIRE GAUGE SIZE	PACKAGE QUANTITY
OD087	87	12
OD080	80	12
OD079	79	12
OD078	78	12
OD077	77	12
OD076	76	12
OD075	75	12
OD074	74	12
OD073	73	12
OD072	72	12
OD071	71	12
OD070	70	12
OD069	69	12
OD068	68	12
OD067	67	12
OD066	66	12
OD065	65	12
OD064	64	12
OD063	63	12
OD062	62	12
OD061	61	12

**HIGH SPEED STEEL**  
JOBBER'S LENGTH 135° SPLIT POINT



STOCK NO.	WIRE GAUGE SIZE	PACKAGE QUANTITY
VT114200	60	12
VT114218	59	12
VT114226	58	12
VT114234	57	12
VT114242	56	12
VT114259	55	12
VT114267	54	12
VT114275	53	12
VT114283	52	12
VT114291	51	12
VT114309	50	12
VT114317	49	12
VT114325	48	12
VT114333	47	12
VT114341	46	12
VT114358	45	12
VT114366	44	12
VT114374	43	12
VT114382	42	12
VT114390	41	12
VT114408	40	12
VT114416	39	12
VT114424	38	12
VT114432	37	12
VT114440	36	12
VT114457	35	12
VT114465	34	12
VT114473	33	12
VT114481	32	12
VT114499	31	12
VT114507	30	12
VT114515	29	12
VT114523	28	12
VT114531	27	12
VT114549	26	12
VT114556	25	12
VT114564	24	12
VT114572	23	12
VT114580	22	12
VT114598	21	12
VT114606	20	12
VT114614	19	12
VT114622	18	12
VT114630	17	12
VT114648	16	12
VT114655	15	12
VT114663	14	12
VT114671	13	12
VT114689	12	12
VT114697	11	12
VT114705	10	12
VT114713	9	12
VT114721	8	12
VT114739	7	12
VT114747	6	12
VT114754	5	12
VT114762	4	12
VT114770	3	12
VT114788	2	12
VT114796	1	12

**HIGH SPEED STEEL**  
JOBBER'S LENGTH 135° SPLIT POINT



STOCK NO.	DIAMETER	PACKAGE QUANTITY
VT116008	A	12
VT116016	B	12
VT116024	C	12
VT116032	D	12
VT116040	E	12
VT116057	F	12
VT116065	G	12
VT116073	H	12
VT116081	I	12
VT116099	J	12
VT116107	K	12
VT116115	L	12
VT116123	M	6
VT116131	N	6
VT116149	O	6
VT116156	P	6
VT116164	Q	6
VT116172	R	6
VT116180	S	6
VT116198	T	6
VT116206	U	6
VT116214	V	6
VT116222	W	6
VT116230	X	6
VT116248	Y	6
VT116255	Z	6

**WE STOCK  
POPULAR SIZES.**



**CALL US  
FOR YOUR NEEDS  
ADDITIONAL  
BITS AVAILABLE  
UPON REQUEST.**

**CALL US FOR ALL YOUR NEEDS  
855-785-TOOL**

### HEAVY DUTY DRILLS / STRAIGHT SHANK

**HIGH SPEED STEEL**  
SCREW MACHINE LENGTH  
(STUB LENGTH)  
135° SPLIT POINT



STOCK NO.	DIAMETER (INCHES)	PACKAGE QUANTITY
VT136410	1/16	12
VT136428	5/64	12
VT136436	3/32	12
VT136444	7/64	12
VT136451	1/8	12
VT136469	9/64	12
VT136477	5/32	12
VT136485	11/64	12
VT136493	3/16	12
VT136501	13/64	12
VT136519	7/32	12
VT136527	15/64	12
VT136535	1/4	12
VT136543	17/64	12
VT136550	9/32	12
VT136568	19/64	6
VT136576	5/16	6
VT136584	21/64	6
VT136592	11/32	6
VT136600	23/64	6
VT136618	3/8	6
VT136626	25/64	6
VT136634	13/32	6
VT136642	27/64	6
VT136659	7/16	6
VT136667	29/64	6
VT136675	15/32	6
VT136683	31/64	6
VT136691	1/2	6

**YOU  
CAN  
DEPEND  
US!**

**HIGH SPEED STEEL**  
SCREW MACHINE LENGTH  
(STUB LENGTH)  
135° SPLIT POINT



STOCK NO.	WIRE GAUGE SIZE	PACKAGE QUANTITY
134001	60	12
134019	59	12
134027	58	12
134035	57	12
134043	56	12
134050	55	12
134068	54	12
134076	53	12
134084	52	12
134092	51	12
134100	50	12
134118	49	12
134126	48	12
134134	47	12
134142	46	12
134159	45	12
134167	44	12
134175	43	12
134183	42	12
134191	41	12
134209	40	12
134217	39	12
134225	38	12
134233	37	12
134241	36	12
134258	35	12
134266	34	12
134274	33	12
VT134282	32	12
VT134290	31	12
VT134308	30	12
134316	29	12
134324	28	12
VT134332	27	12
134340	26	12
134357	25	12
134365	24	12
134373	23	12
134381	22	12
134399	21	12
VT134407	20	12
134415	19	12
134423	18	12
134431	17	12
134449	16	12
134456	15	12
134464	14	12
134472	13	12
134480	12	12
VT134498	11	12

(CONTINUED TOP OF NEXT COLUMN)

**HIGH SPEED STEEL(CONT)**  
SCREW MACHINE LENGTH  
(STUB LENGTH)  
135° SPLIT POINT



STOCK NO.	WIRE GAUGE SIZE	PACKAGE QUANTITY
134506	10	12
VT134514	9	12
134522	8	12
VT134530	7	12
134548	6	12
VT134555	5	12
134563	4	12
VT134571	3	12
VT134589	2	12
VT134597	1	12



**WE STOCK POPULAR SIZES. CALL US FOR YOUR NEEDS.  
ADDITIONAL BITS AVAILABLE UPON REQUEST.**

**REDUCED SHANK DRILL BITS**

**3/8" SHANK HIGH SPEED STEEL**



STOCK NO.	DIAMETER (INCHES)	PACKAGE QUANTITY
HAN71825	25/64	6
HAN71826	13/32	6
HAN71827	27/64	6
HAN71828	7/16	6
HAN71829	29/64	6
HAN71830	15/32	6
HAN71831	31/64	6
HAN71832	1/2	6
SKF0205916	9/16	1
SKF020558	5/8	1

**WE  
STOCK  
POPULAR  
SIZES.**



**CALL  
US  
FOR  
YOUR  
NEEDS.**

**ADDITIONAL  
BITS  
AVAILABLE  
UPON  
REQUEST.**

**1/2" SHANK HIGH SPEED**

118° POINT ANGLE  
6" OVERALL LENGTH  
3" FLUTE LENGTH



STOCK NO.	DIAMETER (INCHES)	PACKAGE QUANTITY
VT164206	33/64	1
VT164074	17/32	1
VT164214	35/64	1
VT164075	9/16	1
ITM218HS3664*	9/16	1
VT164222	37/64	1
VT164076	19/32	1
VT164230	39/64	1
VT164077	5/8	1
ITM218HS4064*	5/8	1
VT164248	41/64	1
VT164078	21/32	1
VT164255	43/64	1
VT164079	11/16	1
VT164263	45/64	1
VT164082	23/32	1
VT164271	47/64	1
VT164073	3/4	1
VT164289	49/64	1
VT164081	25/32	1
VT164297	51/64	1
VT164099	13/16	1
VT164305	53/64	1
VT164107	27/32	1
VT164313	55/64	1
VT164115	7/8	1
VT164321	57/64	1
VT164123	29/32	1
VT164339	59/64	1
VT164131	15/16	1
VT164347	61/64	1
VT164149	31/32	1
VT164354	63/64	1
VT164156	1"	1
-	1-1/64	1
VT164446	1-1/32	1
-	1-3/64	1
VT164164	1-1/16	1
-	1-5/64	1
-	1-3/32	1
-	1-7/64	1
VT164172	1-1/8	1
-	1-9/64	1
-	1-5/32	1
-	1-11/64	1
VT164180	1-3/16	1
-	1-13/64	1
-	1-7/32	1
-	1-15/64	1
VT164198	1-1/4	1
SKF023415160	1-5/16	1
SKF0234138	1-3/8	1
SKF023411200	1-1/2	1

\*12" OVERALL LENGTH, 9" FLUTE LENGTH

**S & D SETS**

1/2" REDUCED SHANK HIGH SPEED STEEL  
FRACTIONAL SIZES  
IN METAL CASES



STOCK NUMBER NO.	RANGE OF SIZES OF DRILLS	
SKF090850	9/16, 5/8, 3/4, 7/8, 1"	5
CHPXG12-8P	9/16 TO 1" BY 16THS	8

**IF YOU  
DON'T SEE  
SOMTHING  
HERE  
YOU NEED,  
GIVE US  
A  
CALL.  
WE WILL  
DO OUR  
BEST TO FIND  
IT  
FOR YOU.**

WHETHER ON THE ROAD OR IN AN ARGUMENT, WHEN YOU SEE RED IT'S TIME TO STOP.

--JOEY ADAMS

???QUESTIONS???



**CALL US  
WE WANT TO HELP!**

**GENERAL PURPOSE DRILLS / REGULAR TAPER SHANKS**

REGULAR TAPER SHANKS HIGH SPEED STEEL 118° INCLUDED POINT ANGLE			
STOCK NO.	DIAMETER (INCHES)	MORSE TAPER	PACKAGE QUANTITY
VT183081	1/4	1	1
VT183099	17/64	1	1
VT183107	9/32	1	1
VT183115	19/64	1	1
VT183123	5/16	1	1
VT183131	21/64	1	1
VT183149	11/32	1	1
VT183156	23/64	1	1
VT183164	3/8	1	1
VT183172	25/64	1	1
VT183180	13/32	1	1
VT183198	27/64	1	1
VT183206	7/16	1	1
VT183214	29/64	1	1
VT183222	15/32	1	1
VT183230	31/64	2	1
VT183248	1/2	2	1
VT183255	33/64	2	1
VT183263	17/32	2	1
VT183271	35/64	2	1
VT183289	9/16	2	1
VT183297	37/64	2	1
VT183305	19/32	2	1
VT183313	39/64	2	1
VT183321	5/8	2	1
VT183339	41/64	2	1
VT183347	21/32	2	1
VT183354	43/64	2	1
VT183362	11/16	2	1
VT183370	45/64	2	1
VT183388	23/32	2	1
VT183396	47/64	2	1
VT183404	3/4	2	1
VT183412	49/64	2	1
VT183420	25/32	2	1
VT183438	51/64	3	1
VT183446	13/16	3	1
VT183453	53/64	3	1
VT183461	27/32	3	1
VT183479	55/64	3	1
VT183487	7/8	3	1
VT183495	57/64	3	1
VT183503	29/32	3	1
VT183511	59/64	3	1
VT183529	15/16	3	1
VT183537	61/64	3	1
VT183545	31/32	3	1
VT183552	63/64	3	1
VT183560	1	3	1
VT183578	1-1/64	3	1
VT183586	1-1/32	3	1
-	1-3/64	3	1

REGULAR TAPER SHANK HIGH SPEED STEEL 118° INCLUDED POINT ANGLE			
STOCK NO.	DIAMETER (INCHES)	MORSE TAPER	PACKAGE QUANTITY
VT183602	1-1/16	3	1
-	1-5/64	3	1
VT183628	1-3/32	4	1
VT183636	1-7/64	4	1
VT183644	1-1/8	4	1
-	1-9/64	4	1
VT183669	1-5/32	4	1
-	1-11/64	4	1
VT183685	1-3/16	4	1
-	1-13/64	4	1
VT183702	1-7/32	4	1
-	1-15/64	4	1
VT183727	1-1/4	4	1
-	1-17/64	4	1
-	1-9/32	4	1
-	1-19/64	4	1
VT183768	1-5/16	4	1
-	1-21/64	4	1
VT183784	1-11/32	4	1
-	1-23/64	4	1
VT183802	1-3/8	4	1
-	1-25/64	4	1
-	1-13/32	4	1
-	1-27/64	4	1
-	1-7/16	4	1
-	1-29/64	4	1
-	1-15/32	4	1
-	1-31/64	4	1
SKF0302112	1-1/2	4	1
-	1-17/32	5	1
-	1-9/16	5	1
-	1-19/32	5	1
SKF0302158	1-5/8	5	1
-	1-21/32	5	1
-	1-11/16	5	1
-	1-23/32	5	1
SKF0302134	1-3/4	5	1
-	1-25/32	5	1
-	1-13/16	5	1
-	1-27/32	5	1
SKF0302178	1-7/8	5	1
-	1-29/32	5	1
-	1-15/16	5	1
-	1-31/32	5	1
SKF03022	2	5	1

TAPER SHANK DRILL BITS EXTRA LENGTH HIGH SPEED STEEL PRECISION GROUND 18" OVERALL LENGTH			
STOCK NO.	DIA. (INCHES)	MORSE TAPER	PACKAGE QUANTITY
STC5623362	9/16	2	1
STC5623382	19/32	2	1
STC5623402	5/8	2	1
STC5623422	21/32	2	1
STC5623442	11/16	2	1
STC5623462	23/32	2	1
STC5623482	3/4	2	1
STC5623502	25/32	2	1
STC5623523	13/16	3	1
STC5623543	27/32	3	1
STC5623563	7/8	3	1
STC5623583	29/32	3	1
STC5623603	15/16	3	1
STC5623643	1"	3	1
STC5623683	1-1/16	3	1
STC5623724	1-1/8	4	1
STC5623764	1-3/16	4	1
STC5623804	1-1/4	4	1

**OUR STAFF IS ALWAYS  
AT YOUR SERVICE  
CALL  
TO PLACE AN ORDER,**



**AND REMEMBER  
TO HAVE THIS  
VALUABLE CATALOG  
NEARBY!**

**CALL US FOR ALL YOUR NEEDS  
855-785-TOOL**

**STRAIGHT SHANK - EXTRA LENGTH AND AIRCRAFT EXTENSION DRILL BITS**

**EXTRA LENGTH DRILLS**

STANDARD FLUTES  
12" APPROX. OVERALL LENGTH  
(THESE BITS HAVE 9" OF FLUTE  
AND 3" OF SHANK)



STOCK NO.	SIZE EQUIV.	PACKAGE QUANTITY
-	1/16	1
-	5/64	1
-	3/32	1
-	7/64	1
SKF025618	1/8	1
-	9/64	1
SKF0256532	5/32	1
-	11/64	1
SKF0256316	3/16	1
-	13/64	1
SKF0256732	7/32	1
-	15/64	1
SKF025614	1/4	1
-	17/64	1
SKF0256932	9/32	1
-	19/64	1
SKF0256516	5/16	1
-	21/64	1
SKF02561132	11/32	1
-	23/64	1
SKF025638	3/8	1
-	25/64	1
SKF02561332	13/32	1
SKF02562764	27/64	1
SKF0256716	7/16	1
-	29/64	1
SKF02561532	15/32	1
-	31/64	1
SKF025612	1/2	1
-	33/64	1
SKF02561732	17/32	1
-	35/64	1
SKF0256916	9/16	1
-	37/64	1
-	19/32	1
-	39/64	1
SKF025658	5/8	1
-	21/32	1
SKF02561116	11/16	1
-	23/32	1
SKF025634	3/4	1
-	25/32	1
DTAM52052	13/16	1
-	7/8	1
-	15/16	1
-	1"	1
-	1-1/16	1
-	1-1/8	1
-	1-3/16	1
-	1-1/4	1

**TAPER LENGTH  
HIGH SPEED STEEL  
PRECISION GROUND**



STOCK NO.	DIA (INCHES)	OVERALL LENGTH
-	1/64	1-3/4
-	1/32	2-7/8
-	3/64	2-1/4
OD203	1/16	3"
-	5/64	3-3/4
OD205	3/32	4-1/4
OD206	7/64	4-5/8
OD207	1/8	5-1/8
OD208	9/64	5-3/8
OD209	5/32	5-3/8
OD210	11/64	5-3/4
OD211	3/16	5-3/4
OD212	13/64	6"
OD213	7/32	6"
OD214	15/64	6-1/8
OD215	1/4	6-1/8
OD216	17/64	6-1/4
OD217	9/32	6-1/4
OD218	19/64	6-3/8
OD219	5/16	6-1/2
OD220	21/64	6-1/2
OD221	11/32	6-1/2
OD222	23/64	6-3/4
OD223	3/8	6-3/4
OD224	25/64	7"
OD225	13/32	7"
OD226	27/64	7-1/4
OD227	7/16	7-1/4
OD228	29/64	7-1/2
OD229	15/32	7-1/2
OD230	31/64	7-3/4
OD231	1/2	7-3/4
-	33/64	8"
-	17/32	8"
-	35/64	8-1/4
OD233	9/16	8-1/4
-	37/64	8-3/4
-	19/32	8-3/4
-	39/64	8-3/4
OD235	5/8	8-3/4
-	41/64	9"
-	21/32	9"
-	43/64	9-1/4
-	11/16	9-1/4
-	45/64	9-1/2
-	23/32	9-1/2
-	47/64	9-3/4
OD238	3/4	9-3/4
OD240	1"	11"

LETTER AND NUMBER SIZES  
AVAILABLE UPON REQUEST

**6 INCH AIRCRAFT EXTENSION  
HIGH SPEED STEEL  
135° SPLIT POINT  
BLACK OXIDE FINISH**



STOCK NO.	DIA (INCHES)	PACKAGE QUANTITY
-	3/64	6
HAN66604	1/16	6
HAN66605	5/64	6
HAN66606	3/32	6
HAN66607	7/64	6
HAN66608	1/8	6
HAN66609	9/64	6
HAN66610	5/32	6
HAN66611	11/64	6
HAN66612	3/16	6
HAN66613	13/64	6
HAN66614	7/32	6
HAN66615	15/64	6
HAN66616	1/4	6
HAN66618	9/32	6
HAN66620	5/16	6
HAN66622	11/32	6
HAN66624	3/8	6
-	13/32	6
-	7/16	6
-	1/2	6

**12 INCH AIRCRAFT EXTENSION  
HIGH SPEED STEEL  
135° SPLIT POINT  
BLACK OXIDE FINISH  
(THESE BITS HAVE 3" OF FLUTE  
AND 9" OF SHANK)**



STOCK NO.	DIA. (INCHES)	PACKAGE QUANTITY
-	3/64	6
-	1/16	6
-	5/64	6
-	3/32	6
-	7/64	6
HAN61208	1/8	6
-	9/64	6
-	5/32	6
-	11/64	6
HAN61212	3/16	6
-	13/64	6
-	7/32	6
-	15/64	6
HAN61216	1/4	6
-	9/32	6
HAN61220	5/16	6
-	11/32	6
HAN61224	3/8	6
HAN61226	13/32	6
HAN61228	7/16	6
HAN61232	1/2	6

### SPECIALTY DRILL BITS

**COBALT DRILLS  
JOBBER LENGTH  
135° SPLIT POINT**



COBALT JOBBER LENGTH DRILLS ARE MADE FROM PREMIUM COBALT HIGH SPEED STEEL WITH HEAVY DUTY CONSTRUCTION. DUE TO THE HEAT-RESISTANT CHARACTERISTICS OF THEIR PREMIUM COBALT STEEL, THESE DRILLS ARE USED IN DRILLING HARD, TOUGH, HIGH TENSILE STRENGTH MATERIALS, SUCH AS TITANIUM ALLOYS AND CHROME-NICKEL STEELS, WHICH CAUSE HIGH HEAT TO BE GENERATED WHEN CUT. THEIR HEAT-RESISTANCE AND HEAVY DUTY DESIGN ALSO ENABLE THESE DRILLS TO BE USED IN DIFFICULT APPLICATIONS WITH MUCH HIGHER THAN ORDINARY SPEEDS AND FEEDS.

STOCK NO.	DIAMETER INCHES	PACKAGE QUANTITY
OD101	1/16	12
OD102	5/64	12
OD103	3/32	12
OD104	7/64	12
OD105	1/8	12
OD106	9/64	12
OD107	5/32	12
OD108	11/64	12
OD109	3/16	12
OD110	13/64	12
OD111	7/32	12
OD112	15/64	12
OD113	1/4	12
OD114	17/64	12
OD115	9/32	12
OD116	19/64	12
OD117	5/16	12
OD118	21/64	6
OD119	11/32	6
OD120	23/64	6
OD121	3/8	6
OD122	25/64	6
OD123	13/32	6
OD124	27/64	6
OD125	7/16	6
OD126	29/64	6
OD127	15/32	6
OD128	31/64	6
OD129	1/2	6

**COBALT DRILLS - 1/2" SHANK  
135° SPLIT POINT  
6" OVERALL LENGTH  
3" FLUTE LENGTH**



PACKAGED INDIVIDUALLY

STOCK NO.(INCHES)	DIAMETER QUANTITY	PACKAGE QUANTITY
OD1294	9/16	1
OD1298	5/8	1
OD1300	21/32	1
OD1302	11/16	1
OD1306	3/4	1
OD1310	13/16	1
OD1314	7/8	1
OD1318	15/16	1
OD1322	1"	1

**MECHANICS LENGTH DRILL BITS  
MAGNUM SUPER PREMIUM  
MECHANICS LENGTH  
(SHORTER THAN JOBBER LENGTH)  
135° SPLIT POINT  
3-FLATS ON SHANK ON  
SIZES 3/16 AND LARGER**



STOCK NO.	DIAMETER	PACKAGE QUANTITY
22860	1/16	12
22870	5/64	12
22880	3/32	12
86950	7/64	12
CD86960	1/8	12
CD86970	9/64	12
CD86980	5/32	12
CD86990	11/64	12
CD87000	3/16	12
CD87010	13/64	12
CD87020	7/32	12
CD87030	15/64	12
CD87040	1/4	12
CD87050	17/64	12
CD87060	9/32	12
CD87070	19/64	6
CD87080	5/16	6
CD87090	21/64	6
CD87100	11/32	6
CD87110	23/64	6
CD87120	3/8	6
CD87130	25/64	6
CD87140	13/32	6
CD87150	27/64	6
CD87160	7/16	6
CD87170	29/64	6
CD87180	15/32	6
CD87190	31/64	6
CD87200	1/2	6

**TWIN DRILLS  
HIGH SPEED STEEL  
SCREW MACHINE LENGTH  
(STUB LENGTH)  
135° SPLIT POINT**



STOCK NO.	DIAMETER (INCHES)	PACKAGE QUANTITY
OD316	1/8	12
OD324	1/4	12

**LEFT HAND DRILL BITS  
HIGH SPEED STEEL  
JOBBER LENGTH  
135° SPLIT POINT**



STOCK NO.	DIAMETER	PACKAGE QUANTITY
OD302	1/8	6
OD304	3/16	6
OD306	1/4	6
OD307	5/16	3
OD308	3/8	3

**TITANIUM NITRIDE COATED DRILLS  
FRACTIONAL SIZES  
JOBBER LENGTH  
135° SPLIT POINT  
STRAIGHT SHANK**



TITANIUM NITRIDE COATING IS A REFRACTORY COMPOUND WITH EXTREME HARDNESS AND HEAT RESISTANCE. IT IS MORE THAN TWICE AS HARD AS HIGH SPEED STEEL - HARDER THAN TUNGSTEN CARBIDE. TITANIUM NITRIDE COATED TOOLS CAN BE REGROUND AND IN CASES STILL OUTPERFORM NORMAL HIGH SPEED STEEL TOOLS BY TWO TIMES, OR MORE. 135° SPLIT POINT ALLOWS EASIER PENETRATION AND HELPS ELIMINATE DRILL WALKING.

STOCK NO.	DIAMETER (INCHES)	PACKAGE QUANTITY
VTV119016	1/16	6
VTV119024	5/64	6
VTV119032	3/32	6
VTV119040	7/64	6
VTV119057	1/8	6
VTV119065	9/64	6
VTV119073	5/32	6
VTV119081	11/64	6
VTV119099	3/16	6
VTV119107	13/64	6
VTV119115	7/32	6
VTV119123	15/64	6
VTV119131	1/4	6
VTV119149	17/64	6
VTV119156	9/32	6
VTV119164	19/64	3
VTV119172	5/16	3
VTV119180	21/64	3
VTV119198	11/32	3
VTV119206	23/64	3
VTV119214	3/8	3
VTV119222	25/64	3
VTV119230	13/32	3
VTV119248	27/64	3
VTV119255	7/16	3
VTV119263	29/64	3
VTV119271	15/32	3
VTV119289	31/64	3
VTV119297	1/2	3

**ADDITIONAL  
BITS  
AVAILABLE  
UPON  
REQUEST.**

**SOLID CARBIDE / CARBIDE TIP / CARBIDE DIE DRILL BITS**

**CARBIDE TIPPED 13/16 HOLE CUTTER**



THIS HOLE CUTTER FEATURES TWO SETS OF THREE CUTTING BLADES, EACH WITH DIFFERENT GEOMETRIES. THIS UNIQUE SYSTEM BALANCES THE CUTTING FORCES ENABLING RAPID, SMOOTH DRILLING WITH BETTER CONTROL. ONE PIECE CONSTRUCTION, SPECIAL TUNGSTEN CARBIDE TEETH, EJECTOR SPRING, AND SAFETY COLLAR STOP.

STOCK NO.	DIAMETER (INCHES)	PACKAGE QUANTITY
CHPCT706250	5/8	1
CHPCT706875	11/16	1
CHPCT707500	3/4	1
CHPCT78125	13/16	1
CHPCT710000	1"	1

**ROTO BRUTE CARBIDE SET**

THIS SET WILL DRILL STEEL UP TO 3/16" THICK. SET INCLUDES SIZES 7/8", 1-1/8", 1-3/8", 1-3/4", AND 2" IN A METAL CASE.



STOCK NO. CHPCT5SET1

THIS SET WILL DRILL STEEL UP TO 1" THICK. SET INCLUDES SIZES 11/16", 13/16", 15/16", AND 1-1/16" IN A METAL CASE.



STOCK NO. CHPCT7SET1

**ADDITIONAL  
BITS  
AVAILABLE  
UPON  
REQUEST.**

**SOLID CARBIDE DRILL BITS**

118° POINT  
STRAIGHT SHANK  
FOR NON-FERROUS METALS



STOCK NO.	DIA (INCHES)	PACKAGE QUANTITY
SGS50	1/16	1
SGS51	5/64	1
SGS52	3/32	1
SGS53	7/64	1
SGS54	1/8	1
SGS55	9/64	1
SGS56	5/32	1
SGS57	11/64	1
SGS58	3/16	1
SGS59	13/64	1
SGS60	7/32	1
SGS61	15/64	1
SGS62	1/4	1
SGS63	17/64	1
SGS64	9/32	1
SGS65	19/64	1
SGS66	5/16	1
SGS67	21/64	1
SGS68	11/32	1
SGS69	23/64	1
SGS70	3/8	1
SGS71	25/64	1
SGS72	13/32	1
SGS73	27/64	1
SGS74	7/16	1
SGS75	29/64	1
SGS76	15/32	1
SGS77	31/64	1
SGS78	1/2	1

**SOLID CARBIDE DRILL BITS**

FOR DRILLING HARD OR HEAT TREATED MATERIALS



STOCK NO.	DIA (INCHES)	PACKAGE QUANTITY
SGS921	3/8	1
SGS929	1/2	1

**WE STOCK  
POPULAR SIZES.  
CALL  
US  
FOR  
YOUR NEEDS.**

**CARBIDE TIP DRILL BITS  
TOOL STEEL BODY, CARBIDE TIP**  
118° POINT, BRIGHT FINISH  
FOR NON-FERROUS MATERIALS  
-NOT STEEL



STOCK NO.	DIA (INCHES)	PACKAGE QUANTITY
CHP705CT14	1/4	1
CHP705CT516	5/16	1
CHP705CT38	3/8	1
CHP705CT716	7/16	1
CHP705CT12	1/2	1

**CARBIDE DIE DRILL BITS**

**CARBIDE TIP  
STRAIGHT FLUTE**



FOR NON-PRECISION DRILLING OF HARDENED STEEL AND SAFES. IDEAL FOR DRILLING AND EXTRACTING BROKEN HARDENED BOLTS.

STOCK NO.	DESCRIPTION
CHPCT705146	1/4 x 6"
CHPCT7055166	5/16 x 6"
CHPCT705386	3/8 x 6"
CHPCT705126	1/2 x 6"

**PRICES  
AND  
COMPLETE  
INFORMATION  
IS  
AVAILABLE  
UPON  
REQUEST!**

NOSTALGIA IS LIKE A GRAMMAR LESSON: YOU FIND THE PRESENT TENSE AND THE PAST PERFECT.  
--THE UNITED CHURCH OBSERVER

## DRILL INDEXES, GAUGES AND ACCESSORIES

### DRILL INDEXES



ORGANIZERS FEATURE PANELS THAT STAND UPRIGHT AND FOLD LIKE BOOK PAGES. DECIMAL EQUIVALENTS. PERMANENT, RAISED (EMBOSSSED) LETTERING. DURABLE STEEL WITH BAKED EPOXY FINISH. FITS IN 2" DEEP TOOL DRAWER.

STOCK NO.	DESCRIPTION
HU313	FOR JOBBERS LENGTH 1/16" - 1/4" BY 64ths. SIZE 2-1/16" x 4-1/8" x 5/8".
HU15	FOR JOBBERS LENGTH 1/16" - 1/2" BY 32nds. SIZE 4" x 7" x 1-1/4".
HU26	FOR LETTER SIZE DRILLS A-Z. SIZE 4" x 7" x 1-3/4".
HU29	FOR JOBBERS LENGTH 1/16" - 1/2" BY 64ths. SIZE 4" x 7" x 1-3/4". DECIMAL EQUIVALENTS AND USS TAP INFORMATION.
HU60	FOR WIRE GAUGE DRILLS 1-60. SIZE 3-1/4" x 4-1/2" x 1". DECIMAL EQUIVALENTS AND MACHINE SCREW TAP INFORMATION.
HU80	FOR WIRE GAUGE DRILLS 1-80. SIZE 3-1/4" x 4-1/2" x 1-5/16".
HU2029	FOR STUB & SCREW MACHINE LENGTH DRILLS 1/16" - 1/2" BY 64ths. DECIMAL EQUIVALENTS AND USS TAP INFORMATION. SIZE 4" x 7" x 1-3/4".
<b>TAP &amp; DRILL INDEX</b>	
HU99	HOLDS NATIONAL COARSE SIZES 6-32 TAP #36 DRILL, 8-32 #29, 10-24 #25, 10-32 #21, 1/4-20 #7, 5/16-18 #F, 3/8-16 #5/16, 7/16-14 #U, 1/2-13 #27/64. SIZE 4" x 7" x 1-1/4".

### FRACTIONAL DRILL STAND

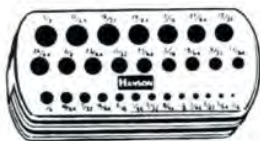

HOLDS 29 DRILL SIZES 1/16" - 1/2" BY 64ths. SIZE 5-3/4" x 2-5/8" x 1-3/4". STURDY METAL.

STOCK NO. HAN60172

EVERYWHERE IS WALKING DISTANCE IF YOU HAVE THE TIME.

--STEVEN WRIGHT

### DRILL GAUGES

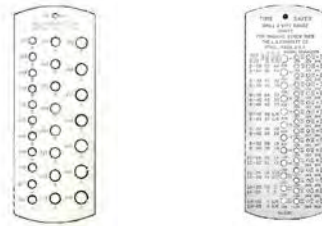

#### NUMBER DRILL GAUGE

**1-60 TWIST DRILL AND MACHINE SCREW TAP GAUGE:** TELLS AT A GLANCE THE CORRECT SIZE TAP DRILL FOR MACHINE SCREW TAP IN NATIONAL FINE (NF) OR NATIONAL COARSE (NC) THREAD SERIES. SHOWS THE CORRECT BODY SIZE DRILL TO USE. DECIMAL EQUIVALENTS. STOCK NO. ST25001600

#### FRACTIONAL DRILL GAUGE

**1/16 to 1/2 FRACTIONAL SIZE GAUGE:** HAS 29 MEASURING HOLES FOR DETERMINING TWIST DRILL SIZES IN 1/64 INCREMENTS. DECIMAL EQUIVALENTS. STOCK NO. ST25001700  
STOCK NO. HU9092 (ECONOMY)

#### LETTER DRILL GAUGE

**A-Z ALPHABET DRILL GAUGE:** EACH HOLE IS MARKED BY LETTER SIZE AND ITS DECIMAL EQUIVALENTS FROM .234 INCH DIAMETER THROUGH .413 INCH DIAMETER. STOCK NO. ST25001800

### DRILL GRINDING ATTACHMENT



SHARPENS DRILL BITS TO FACTORY ACCURACY. EXTENDS BIT LIFE. ANGLE ADJUSTMENTS LOCK IN TO GRIND BITS FOR MORE ACCURATE DRILLING IN A VARIETY OF MATERIALS. ADJUST AUTOMATICALLY. FOR USE WITH ANSI, OSHA AND UL APPROVED STANDARD

ELECTRIC BENCH GRINDERS OR SURFACE GRINDERS. CAPACITY: 1/8" - 3/4" DRILLS NUMBER DRILLS 30 - 1, LETTER DRILLS A - Z, MILLIMETER DRILLS 3.0 - 19.0.

STOCK NO. GEN825

### DRILL STOP SET



FOR USE ON TWIST OR BRAD POINT DRILLS TO PREVENT EXCESSIVE DRILL PENETRATION. POSITIVE DEPTH CONTROL ASSURES EXACT HOLE DEPTHS FOR MULTIPLE DRILLING JOBS. BLACK OXIDE FINISH ON COLD ROLLED STEEL. SIZES: 3/16", 1/4", 5/16", 3/8", 7/16", 1/2". HEX WRENCH INCLUDED.

STOCK NO. GENS838

### DRILL DOCTOR



RENEW DULL WORN OUT DRILL BITS TO PRECISION SHARPMNESS WITH THE DRILL DOCTOR. STOP THROWING YOUR COSTLY BROKEN DRILL BITS INTO THE TRASH. SHARPEN THE COMPLETE RANGE OF DRILL BITS 3/32 - 3/4" METRIC AND LETTER SIZES. NEW! CUSTOM POINT--CHOOSE ANY ANGLE FROM 155° TO 140°. ALSO NEW ADJUSTABLE MATERIAL TAKE-OFF SO YOU CAN TOUCH UP A SLIGHTLY DULL BIT OR DEEP GRIND FOR A HEAVILY DAMAGED BIT. COMES WITH TOUGH INJECTION MOLDED, POLYETHYLENE CARRYING AND STORAGE CASE.

STOCK NO. DAREXDD750X

ADAPTER CHUCKS FOR DRILL DOCTOR X500SP



STOCK NO.	SIZE
DAREXSA01500PA	1/2"
DAREXSA01750PA	3/4"

REPLACEMENT SHARPENER DIAMOND WHEEL



STOCK NO. DAREX01

CHUCK STORAGE RACK



STOCK NO. DAREX02



**MORSE TAPER, ANNULAR CUTTERS, UNIBIT STEP DRILLS & DRILL SETS**

**MORSE TAPER DRILL SLEEVES**



STOCK NO.	INSIDE TAPER	OUTSIDE TAPER
SKF980113	1	3
SKF980123	2	3
SKF980124	2	4
SKF980134	3	4
SKF980145	4	5

**MORSE TAPER SOCKETS**



STOCK NO.	INSIDE TAPER	OUTSIDE TAPER
SKF981232	3	2
SKF981243	4	3

**DRILL DRIFTS**



STOCK NO. STC1960001 (#1 DRIFT)  
STOCK NO. STC1960002 (#2 DRIFT)  
STOCK NO. STC1960003 (#3 DRIFT)  
STOCK NO. STC1960004 (#4 DRIFT)

**UNIBIT STEP DRILLS**

THE SINGLE RADIAL CONCAVE FLUTE DESIGN MEANS SMOOTH, EVEN CUTTING. IDEAL FOR STEEL, COPPER, BRASS, ALUMINUM AND OTHER THIN MATERIALS. SELF-STARTING TIP WON'T SKID. MADE OF INDUSTRIAL-GRADE HIGH SPEED MOLYBDENUM STEEL.



STOCK NO.	TYPE A MULTIPLE-HOLE SIZES		TYPE B SINGLE-HOLE SIZES	
	TYPE	SIZE RANGE	TYPE	SIZE RANGE
VG1	A	1/8-1/2		
VG3	A	1/4-3/4		
VG4	A	3/16-7/8		
VG10	B	1/2		
VG11	B	7/8		
VG13	B	1-1/8		

HUMOR IS A REMINDER THAT NO MATTER HOW HIGH THE THRONE ONE SITS ON, ONE SITS ON ONE'S BOTTOM.

--TAKI

**ANNULAR CUTTERS**

HSS/COBALT CUTTERS USED FOR QUICKER AND SMOOTHER CUTTING OF MILD STEEL, STRUCTURAL STEEL, BRIDGE STEEL, CAST IRON AND ALUMINUM. FITS MOST BRANDS OF MAG DRILLS THAT USE A STANDARD 3/4" WELDON SHANK



STOCK NO.	1" DEPTH OF CUT SIZE
NK0250*	7/16 x 1"
COB002	1/2 x 1"
COB003	9/16 x 1"
COB004	5/8 x 1"
COB005	11/16 x 1"
COB006	3/4 x 1"
COB007	13/16 x 1"
COB008	7/8 x 1"
COB009	15/16 x 1"
COB010	1" x 1"
COB011	1-1/16 x 1"
COB012	1-1/8 x 1"
COB013	1-3/16 x 1"
COB014	1-1/4 x 1"
COB015	1-5/16 x 1"
COB016	1-3/8 x 1"
COB017	1-7/16 x 1"
COB018	1-1/2 x 1"

\*COMES WITH PIN



STOCK NO.	2" DEPTH OF CUT SIZE
NK0280*	7/16 x 2"
COB041	1/2 x 2"
COB042	9/16 x 2"
COB043	5/8 x 2"
COB044	11/16 x 2"
COB045	3/4 x 2"
COB046	13/16 x 2"
COB047	7/8 x 2"
COB048	15/16 x 2"
COB049	1" x 2"
COB050	1-1/16 x 2"
COB051	1-1/8 x 2"
COB052	1-3/16 x 2"
COB053	1-1/4 x 2"
COB054	1-5/16 x 2"
COB055	1-3/8 x 2"
COB056	1-7/16 x 2"
COB057	1-1/2 x 2"

\*COMES WITH PIN

**PILOT PINS FOR ANNULAR CUTTERS**



1" DEPTH OF CUT ANNULAR CUTTER  
STOCK NO. NKUEA06250

2" DEPTH OF CUT ANNULAR CUTTER  
STOCK NO. NKUEA06500

**DRILL SETS**



SIZES 1-60 HSS DRILL SET. STURDY METAL CASE.  
STOCK NO. CD88640

SIZES A-Z HSS DRILL SET. STURDY METAL CASE  
STOCK NO. CD88660

SIZES 1/16" - 1/2" DRILL SET (15 PIECE) BY 32nds. STURDY METAL CASE.  
STOCK NO. CD44120

SIZES 1/16" - 1/2" DRILL SET (29 PIECE) BY 64ths. STURDY METAL CASE.  
STOCK NO. CD44150

COBALT DRILL SET (29 PIECE). STURDY METAL CASE - SIZES 1/16" - 1/2"  
STOCK NO. SKF18CO



SIZES 1/16" - 1/2" HSS DRILL SET (15 PIECE). 3/8" REDUCED SHANK. BY 32nds. STURDY METAL CASE  
STOCK NO. HAN60147

SIZES 1/16" - 1/2" HSS DRILL SET (29 PIECE). 3/8" REDUCED SHANK. BY 64ths. STURDY METAL CASE.  
STOCK NO. HAN60148



115 PIECE SET. CONSISTS OF:  
SIZES 1-60 HSS DRILL SET.  
SIZES A-Z HSS DRILL SET.  
SIZES 1/16" - 1/2" DRILL SET BY 64ths.  
STURDY METAL CASE.

STOCK NO. CD93840



29 PIECE SET. CONSISTS OF:  
SIZES 1/16" - 1/2" BY 64THS.  
ULTRADEX PLASTIC WATERPROOF, SHOCKPROOF CASE.

STOCK NO. CD44170

## CARBIDE MASONRY BITS

### CONCRETE HAMMER BITS



THE STANDARD, STRAIGHT SHANK BIT FOR UNIVERSAL APPLICATION IN DRILL MOTORS AND HAMMER DRILLS (ROTARY PERCUSSION TOOLS). FOR MASONRY AND CONCRETE. TUNGSTEN CARBIDE TIP HAS POSITIVE RAKE.

STOCK NO.	DIA	DRILL DEPTH	OVERALL LENGTH
CMB70001	1/8	1-3/8	3"
CMB70004	3/16	1-9/16	3"
CMB70007	3/16	4"	6"
CMB70010	1/4	2-1/8	4"
CMB70013	1/4	4"	6"
CMB70016	1/4	8"	12"
ITM502BU1814	1/4	14"	18"
ITM308CT2401	1/4	20"	24"
CMB70019	5/16	2-3/4	4"
CMB70022	5/16	4"	6"
CMB70025	5/16	9"	12"
ITM502BU1856	5/16	10"	18"
ITM308CT2402	5/16	19"	24"
CMB70028	3/8	4"	6"
CMB70031	3/8	10"	12"
CMB70034	3/8	18"	20"
CMB80035	3/8	21"	24"
CMB70037	7/16	4"	6"
CMB70040	1/2	4"	6"
CMB70043	1/2	10"	12"
CMB70045	1/2	18"	20"
CMB70047	1/2	20"	24"
CMB70049	9/16	3"	6"
CMB70052	5/8	3-1/2	6"
CMB70055	5/8	10"	12"
ITM502BU1858	5/8	11"	18"
CMB70056	5/8	20"	24"
CMB70058	3/4	4"	6"
CMB70061	3/4	9"	12"
ITM502BU1834	3/4	14"	18"
CMB70064	7/8	3"	6"
CMB70067	7/8	9"	13"
CMB70070	1"	4"	6"
CMB70073	1"	10"	12"

### HEAVY-DUTY STRAIGHT SHANK SET



6 PIECE SET INCLUDES:  
3/16" x 3 1/2"; 1/4" x 4"; 1/4" x 6;  
5/16" x 6"; 3/8" x 6"; 1/2" x 6"

STOCK NO. CMB75210

### CARBIDE TIPPED GLASS/TILE DRILLS FOR DRILLING GLASS AND TILE.



(USE ONLY WITH ROTARY DRILLING.  
NO HAMMER DRILLING)

STOCK NO.	SIZE
CMB001	1/8
CMB002	3/16
CMB003	1/4
CMB004	5/16
CMB005	3/8
CMB006	1/2

### SPLINE SHANK BITS



FOR USE IN ROTARY HAMMERS. SPLINES HELD TO VERY CLOSE TOLERANCES. SHOT PEENED FOR TORQUE PROTECTION. FASTER DRILLING WITH UNDERCUT, HELICAL FLUTING. MADE TO ANSI STANDARDS.

STOCK NO.	DIA	DRILL DEPTH	OVERALL LENGTH
CMB93302	3/8	5"	10"
CMB93304	3/8	8"	13"
CMB93312	1/2	5"	10"
CMB93316	1/2	11"	16"
CMB93318	1/2	17"	22"
CMB93330	5/8	5"	10"
CMB93024	5/8	11"	16"
CMB93025	5/8	16"	21"
CMB93031	3/4	5"	10"
CMB93030	3/4	11"	16"
CMB93033	3/4	17"	22"
CMB93039	7/8	11"	16"
CMB93042	7/8	17"	22"
CMB93045	1"	11"	16"
CMB93048	1"	17"	22"
CMB93051	1-1/8	10"	16"
CMB93057	1-1/4	17"	22"
CMB93382	1-3/8	11"	16"
CMB93069	1-1/2	17"	22"
CMB93390	1-3/4	17"	22"
CMB93392	2"	17"	22"

### HAMMER CHISELS FOR SPLINE SHANK ROTARY HAMMERS

#### FLAT HAMMER CHISEL



FOR CHISELING, SCALING, CHIPPING, EDGING & CHANNELING IN BRICK AND CONCRETE.

STOCK NO. CMB79320 (1" x 12")  
STOCK NO. CMB79330 (1" x 18")

#### BULL POINT CHISEL



STANDARD DEMOLITION CHISEL

STOCK NO. CMB79300 (12")  
STOCK NO. CMB79310 (18")

#### SCALING CHISEL



FOR REMOVING WELD SPATTER, SCALE, AND CONCRETE FORM OVERFLOW & SEEPAGE.

STOCK NO. CMB79370 (2" x 12")  
STOCK NO. CMB79372 (2" x 18")

ADDITIONAL SPLINE SHANK BITS AND CHISELS AVAILABLE UPON REQUEST

### SDS-PLUS SHANK BITS



VERSATILE SLOT DRIVE SYSTEM BITS. POSITIVE DRIVE SLOTS DELIVER MAXIMUM DRILLING TORQUE. SMALL FLUTE LANDS PRODUCE LESS HEAT FOR EASIER DRILLING. UNDERCUT DOUBLE FLUTING. FITS ALL ROTARY HAMMERS WITH SDS-PLUS AND HILTI CHUCKS.

STOCK NO.	DIA	DRILL DEPTH	OVERALL LENGTH
CMB90002	5/32	4"	6"
CMB90006	3/16	4"	6"
CMB90013	1/4	4"	6"
CMB90017	1/4	9"	11"
CMB90022	5/16	4"	6"
CMB90025	5/16	10"	12"
CMB90028	3/8	4"	6"
CMB90031	3/8	10-1/4	12"
CMB90037	7/16	4"	6"
CMB90040	1/2	4"	6"
CMB90043	1/2	10-1/4	12"
CMB90045	1/2	16"	18"
CMB90046	1/2	22"	24"
CMB90048	9/16	4-1/4	6"
CMB90053	5/8	6"	8"
CMB90055	5/8	10"	12"
CMB90056	5/8	16"	18"
CMB90054	5/8	22"	24"
CMB90059	3/4	6"	8"
CMB90061	3/4	10"	12"
CMB90063	3/4	16"	18"
CMB90064	3/4	22"	24"
CMB90067	7/8	10-1/4	12"
CMB90071	1"	8"	10"
CMB90076	1"	16"	18"

### SDS-MAX SHANK BITS



TAPERED BODY TRANSFERS MORE TORQUE TO THE CARBIDE CUTTING HEADS. FOUR CARBIDE CUTTING EDGES DRILL 15% FASTER THAN STANDARD BITS. SIZES BELOW 5/8" DIAMETER ARE SINGLE TIP (2-CUTTER) HEAD DESIGN. FITS ALL BOSCH SDS-MAX AND HILTI TE-54, TE-52, TE-60, TE-72, TE-74, TE-92, TE-94 HAMMER DRILLS.

STOCK NO.	DIA	DRILL DEPTH	OVERALL LENGTH
CMB95205	1/2	7-1/2	13"
CMB95210	1/2	15-1/2	21"
CMB95225	5/8	7-1/2	13"
CMB95230	5/8	15-1/2	21"
CMB95235	3/4	8"	13"
CMB95240	3/4	17"	21"
CMB95255	7/8	8"	13"
CMB95260	7/8	17"	21"
CMB95265	1"	8"	13"
CMB95270	1"	17"	21"

ADDITIONAL SDS-PLUS AND SDS-MAX SHANK CARBIDE MASONRY BITS AVAILABLE UPON REQUEST



**DUAL AUGER BITS**



FOR USE IN 3/8" OR LARGER POWER DRILLS AND HAND BRACES. COARSE SCREW POINT FOR FAST BORING. OVERALL LENGTH 7-1/2". CAN BORE THROUGH UP TO 3 STUDS.

STOCK NO.	SIZE
IR49904	1/4
IR49905	5/16
IR49906	3/8
IR49908	1/2
IR49910	5/8
IR49912	3/4
IR49914	7/8
IR49916	1"

**SOLID CENTER AUGER BITS**



BALANCED CUTTING HEAD WITH MEDIUM-FAST SCREW PITCH BORES CLEANER AND FASTER. DOUBLE SPUR, DOUBLE CUTTER. OVERALL LENGTH 18", 12" TWIST.

STOCK NO.	SIZE
IR47704	1/4
IR47705	5/16
IR47706	3/8
IR47708	1/2
IR47709	9/16
IR47710	5/8
IR47712	3/4
IR47714	7/8
IR47716	1"
IR47718	1-1/8

**HSS BRAD POINT BITS**



PRECISION-GROUND FOR USE IN DOWELING WHEN EXACT HOLE SIZES ARE REQUIRED. COMBINATION OF CUTTING EDGES AND SPURS REDUCE SPLINTERING. CHROME VANADIUM.

STOCK NO.	SIZE
IR49612	1/8
IR49613	3/16
IR49614	1/4
IR49615	5/16
IR49616	3/8
IR49617	7/16
IR49618	1/2



**PRICES AND COMPLETE INFORMATION  
 AVAILABLE UPON REQUEST**

**WOOD BORING BITS**

**SPEEDBOR BITS**



SPEEDBOR BITS BORE 2 TIMES FASTER AND LAST 3 TIMES LONGER. FOR 1/4" AND LARGER POWER DRILLS. COMMONLY KNOWN AS SPADE BITS.

STOCK NO.	SIZE
IR88804	1/4
IR88805	5/16
IR88806	3/8
IR88808	1/2
IR88810	5/8
IR88812	3/4
IR88814	7/8
IR88816	1"
IR88818	1-1/8
IR88820	1-1/4
IR88822	1-3/8
IR88824	1-1/2

**6 PIECE SPADE BIT SET**

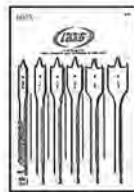

CONTAINS 1 EACH:

- 3/8
- 1/2
- 5/8
- 3/4
- 7/8
- 1"

VINYL POUCH

STOCK NO. IR88899

**12" QUICK CHANGE EXTENSION**



LONG LENGTH HEX SHANK FOR FASTER LOADING. NICKEL PLATING PROVIDES IMPACT AND CORROSION RESISTANCE. INTERNAL HEX DRIVE ELIMINATES SLIPPAGE.

STOCK NO. IR90112

**ADDITIONAL SIZES FOR ALL WOOD BITS ON  
 THIS PAGE AVAILABLE UPON REQUEST**

PATIENCE IS SOMETHING YOU ADMIRE IN THE DRIVER BEHIND YOU AND SCORN IN THE ONE AHEAD.

--MAC MCLEARY



**AUTOMATIC-FEED WOOD BITS**



FEATURES INCLUDE OUTSIDE DIAMETER THREADS AND FORGED BODY. PRECISION GROUND. DEEP CUTTING. 4-1/2" SHANK LENGTH, WITH INDENTATIONS FOR EXTENSION BAR SET SCREWS. OVERALL LENGTH 5-1/2". REPLACEABLE LEAD SCREW.

STOCK NO.	SIZE
LEN33100	1"
LEN33112	1-1/8
LEN33125	1-1/4
LEN33137	1-3/8
LEN33150	1-1/2
LEN33175	1-3/4
LEN33200	2"
LEN33212	2-1/8
LEN33225	2-1/4
LEN33256	2-9/16
LEN33300	3"

WOOD BIT, LEAD SCREW (FITS ALL SIZES)  
 STOCK NO. LEN33900

**AUTOMATIC-FEED WOOD BIT EXTENSIONS**



STOCK NO. LEN30846 (5-1/2")  
 STOCK NO. LEN30847 (12")  
 STOCK NO. LEN30848 (18")

**INSTALLER (BELL HANGER)  
 DRILL BITS**



FOR INSTALLING ALL TYPES OF SMALL WIRE. HOLE IN HEAD OF FLUTE MAKES IT EASY TO PULL WIRES THROUGH HOLE IN WALL. BORING ACTION IS FAST, SMOOTH AND CLEAN.

STOCK NO.	SIZE
IR38505	5/16 x 12"
38605	5/16 x 18"

**QUALITY PRODUCTS,  
 FAIR  
 AND  
 COMPETITIVE PRICES,  
 AND  
 EXCELLENT SERVICE  
 IS  
 OUR REPUTATION.**

### TAPS

**STRAIGHT-FLUTED HAND TAPS**  
 GROUND THREAD - HIGH SPEED STEEL



STOCK NO.	SIZE	TYPE
VT300272	2-56	TAPER
-	2-56	PLUG
VT300819	4-40	TAPER
VT300827	4-40	PLUG
VT300835	4-40	BOTTOM
VT300778*	4-40	BOTTOM
VT300942	4-48	PLUG
VT301056	5-40	TAPER
VT301064	5-40	PLUG
VT301072	5-40	BOTTOM
VT301353	6-32	TAPER
VT301361	6-32	PLUG
VT301379	6-32	BOTTOM
-	6-40	PLUG
VT301742	8-32	TAPER
VT301759	8-32	PLUG
VT301767	8-32	BOTTOM
STC8008401	8-40	PLUG
VT302195	10-24	TAPER
VT302203	10-24	PLUG
VT302211	10-24	BOTTOM
VT302468	10-32	TAPER
VT302476	10-32	PLUG
VT302484	10-32	BOTTOM
VT302526	12-24	TAPER
VT302534	12-24	PLUG
VT302542	12-24	BOTTOM
VT305065	1/4-20	TAPER
VT305073	1/4-20	PLUG
VT305081	1/4-20	BOTTOM
VT305214	1/4-28	TAPER
VT305222	1/4-28	PLUG
VT305230	1/4-28	BOTTOM
VT305396	5/16-18	TAPER
VT305404	5/16-18	PLUG
VT305412	5/16-18	BOTTOM
VT305511	5/16-24	TAPER
VT305529	5/16-24	PLUG
VT305537	5/16-24	BOTTOM
VT305693	3/8-16	TAPER
VT305701	3/8-16	PLUG
VT305719	3/8-16	BOTTOM
VT305818	3/8-24	TAPER
VT305826	3/8-24	PLUG
VT305834	3/8-24	BOTTOM
VT305990	7/16-14	TAPER
VT306006	7/16-14	PLUG
VT306014	7/16-14	BOTTOM
VT306113	7/16-20	TAPER
VT306121	7/16-20	PLUG
VT306139	7/16-20	BOTTOM
VT306295	1/2-13	TAPER
VT306303	1/2-13	PLUG
VT306311	1/2-13	BOTTOM
VT306444	1/2-20	TAPER
VT306451	1/2-20	PLUG
VT306469	1/2-20	BOTTOM
VT306626	9/16-12	TAPER
VT306634	9/16-12	PLUG
VT306642	9/16-12	BOTTOM
VT306741	9/16-18	TAPER
VT306758	9/16-18	PLUG
VT306766	9/16-18	BOTTOM
VT306923	5/8-11	TAPER
VT306931	5/8-11	PLUG
VT306949	5/8-11	BOTTOM
VT307046	5/8-18	TAPER
VT307053	5/8-18	PLUG
VT307061	5/8-18	BOTTOM

(CONTINUED NEXT COLUMN)



### TYPES

**TAPER-** HAVE 8 to 10 THREADS CHAMFERED, AND ARE DESIGNED FOR THREADING THROUGH HOLES.

**PLUG-** HAVE 3 to 5 THREADS CHAMFERED, AND ARE MOST WIDELY USED IN THROUGH HOLES AND IN BLIND HOLES THAT DO NOT HAVE TO BE THREADED ALL THE WAY TO THE BOTTOM.

**BOTTOM-** HAVE 1 to 2 THREADS CHAMFERED AND ARE DESIGNED TO THREAD BLIND HOLES ALL THE WAY TO THE BOTTOM.

**AVAILABLE FROM SINGLE UNITS TO PACK QUANTITIES.**  
**VERTANIUM TAPS AVAILABLE UPON REQUEST.**

STOCK NO.	SIZE	TYPE
HAN1457**	11/16-16	PLUG
VT307343	3/4-10	TAPER
VT307350	3/4-10	PLUG
VT307368	3/4-10	BOTTOM
VT307467	3/4-16	TAPER
VT307475	3/4-16	PLUG
VT307483	3/4-16	BOTTOM
VT307707	7/8-9	TAPER
VT307715	7/8-9	PLUG
VT307723	7/8-9	BOTTOM
VT307822	7/8-14	TAPER
VT307830	7/8-14	PLUG
VT307848	7/8-14	BOTTOM
VT308069	1"-8	TAPER
VT308077	1"-8	PLUG
VT308085	1"-8	BOTTOM
VT308192	1"-12	PLUG
VT308275	1"-14	TAPER
VT308283	1"-14	PLUG
VT308291	1"-14	BOTTOM
-	1-1/8-7	TAPER
VT308432	1-1/8-7	PLUG
VT308465	1-1/8-12	PLUG
VT308549	1-1/4-7	TAPER
VT308556	1-1/4-7	PLUG
VT308564	1-1/4-7	BOTTOM
VT308580	1-1/4-12	PLUG
VT308671	1-3/8-6	PLUG
-	1-3/8-12	PLUG
VT308788	1-1/2-6	TAPER
VT308796	1-1/2-6	PLUG
VT308804	1-1/2-6	BOTTOM
VT308820	1-1/2-12	PLUG
STC8148051	1-3/4-5	PLUG
STC8148121	1-3/4-12	PLUG
WID12	2"-4-1/2	PLUG
WID14	2"-12	PLUG

\*2 FLUTE  
 \*\*HIGH CARBON STEEL

ADDITIONAL TAPS AVAILABLE UPON REQUEST

**TAP SETS**  
 GROUND THREAD - HIGH SPEED STEEL  
 STRAIGHT FLUTE



SETS CONTAIN 1 (ONE) EACH OF THE ABOVE

STOCK NO.	SIZE
-	1-72
VT341573	2-56
-	2-64
VT341599	3-48
VT341607	3-56
VT341623	4-40
VT341649	4-48
VT341664	5-40
-	5-44
VT341706	6-32
VT341714	6-40
VT341748	8-32
VT341755	8-36
VT341789	10-24
VT341813	10-32
VT341821	12-24
VT341839	12-28
VT342522	1/4-20
VT342530	1/4-28
VT342555	5/16-18
VT342563	5/16-24
VT342589	3/8-16
VT342597	3/8-24
VT342605	7/16-14
VT342613	7/16-20
VT342621	1/2-13
VT342639	1/2-20
VT342647	9/16-12
VT342654	9/16-18
VT342662	5/8-11
VT342670	5/8-18
VT342704	3/4-10
VT342712	3/4-16
VT342720	7/8-9
VT342738	7/8-14
-	1"-12
-	1"-14
-	1-1/8-7
-	1-1/4-7
-	1-1/2-12

ADDITIONAL TAP SETS AVAILABLE UPON REQUEST



**TAPS / SETS**



**SPIRAL-POINT TAPS**  
GROUND THREAD - HIGH SPEED STEEL



STOCK NO.	SIZE	TYPE
VT356324	4-40	PLUG
VT356407	5-40	PLUG
VT356506	6-32	PLUG
VT356514	6-32	BOTTOM
VT356633	8-32	PLUG
VT356634	8-32	BOTTOM
VT356704	10-24	PLUG
VT356712	10-24	BOTTOM
VT356761	10-32	PLUG
VT356779	10-32	BOTTOM
VT357041	1/4-20	PLUG
VT357058	1/4-20	BOTTOM
VT357280	5/16-18	PLUG
VT358516	5/16-18+.005"	PLUG
VT357298	5/16-18	BOTTOM
VT357405	5/16-24	PLUG
VT357413	5/16-24	BOTTOM
VT357520	3/8-16	PLUG
-	3/8-24	PLUG
-	7/16-14	PLUG
VT357827	1/2-13	PLUG
VT357926	5/8-11	PLUG
VT357967	3/4-10	PLUG

\*TIN COATED

**HSS PIPE TAPS**  
TAPERED PIPE TAP  
HIGH SPEED STEEL



STOCK NO.	SIZE
DTEM50127	1/16
SKF1010519	1/8
SKF1010520	1/4
SKF1010521	3/8
SKF1010522	1/2
SKF1010523	3/4
SKF1010524	1"
-	1-1/4
-	1-1/2

**CARBON PIPE TAPS**



STOCK NO.	SIZE
HAN1902	1/8
HAN1903	1/4
HAN1904	3/8
HAN1905	1/2
HAN1906	3/4
HAN1907	1"
HAN1908	1-1/4
HAN1909	1-1/2
HAN1910	2"

**NPS PIPE TAPS**



**STRAIGHT PIPE TAP**  
HIGH SPEED STEEL

STOCK NO.	SIZE
STC1010008	1/8
STC1010016	1/4
STC1010024	3/8
STC1010032	1/2

**PULLEY TAPS**  
HIGH SPEED STEEL



STOCK NO.	SIZE	OVERALL LENGTH.
VT373931	1/4-20	6"
VT373956	5/16-18	6"
VT373972	3/8-16	6"
VT384037	1/2-13	6"

**EXTENSION TAPS**  
HIGH SPEED STEEL SPIRAL POINT



STOCK NO.	SIZE	OVERALL LENGTH.
REG15124	1/4-20	6"
REG15130	5/16-18	6"
REG15139	3/8-16	6"
OSG12955	1/2-13	6"

**TAP AND DIE SETS**



ALL CUTTING TOOLS HAVE A BLACK FINISH TO PREVENT CORROSION. SETS ARE PACKED IN A STURDY MOLDED PLASTIC CASE WITH COMPARTMENTS.

**58 PIECE SET**

CONTAINS ONE TAP AND DIE IN EACH OF THE FOLLOWING SIZES:

<b>NC-</b>	6-32, 8-32, 10-24, 12-24, 1/4-20, 5/16-18, 3/8-16, 7/16-14, 1/2-13, 9/16-12, 5/8-11, 3/4-10.
<b>NF-</b>	10-32, 1/4-28, 5/16-24, 3/8-24, 7/16-20, 1/2-20, 9/16-18, 5/8-18, 3/4-16.
<b>NPT-</b>	1/8-27, 1/4-18.

**ACCESSORIES-** 2 DIE STOCKS, 1 T-HANDLE WRENCH, 2 TAP AND REAMER WRENCHES, 1 SCREW PITCH GAUGE, 1 SCREWDRIVER, AND 1-5 SCREW EXTRACTORS.

STOCK NO. VT410044

(CONTINUED ON NEXT PAGE)

**40 PIECE SET**

CONTAINS ONE TAP AND DIE IN EACH OF THE FOLLOWING SIZES:

<b>NC-</b>	4-40, 6-32, 8-32, 10-24, 12-24, 1/4-20, 5/16-18, 3/8-16, 7/16-14, 1/2-13.
<b>NF-</b>	10-32, 1/4-28, 5/16-24, 3/8-24, 7/16-20, 1/2-20.
<b>NPT-</b>	1/8-27

**ACCESSORIES-** 1 DIE STOCK, 2 T-HANDLE WRENCHES, 1 TAP AND REAMER WRENCH, 1 SCREW PITCH GAUGE, 1 SCREWDRIVER.

STOCK NO. VT410036



**METRIC TAP AND DIE SETS**



**41 PIECE METRIC PLUG TAP AND HEX DIE SET**

CONTAINS ONE TAP AND DIE IN EACH OF THE FOLLOWING SIZES:

M3-.5, M4-.7, M4-.75, M5-.8, M5-.9, M6-1.00, M7-1.00, M8-1.00, M8-1.25, M9-1.00, M9-1.25, M10-1.25, M10-1.50, M11-1.50, M12-1.50, M12-1.75  
PIPE- 1/8 - BSP

**ACCESSORIES-** 2 DIE STOCKS, 1 TAP WRENCH, T-TAP WRENCH, T-TAP WRENCH WITH 3/8 SQ. DRIVE, METRIC SCREW PITCH GAUGE AND 1 SCREWDRIVER. HINGED PLASTIC CASE WITH REMOVABLE TRAY.

STOCK NO. HAN26317

**12 PIECE PIPE TAP AND RETHREAD DIE SET**



CONTAINS ONE TAP AND DIE IN EACH OF THE FOLLOWING NPT SIZES: 1/8, 1/4, 3/8, 1/2, 3/4, 1" IN WOODEN CASE

STOCK NO. HAN1920



**PREMIUM TAPS**



**STRAIGHT-FLUTED HAND TAPS**  
GROUND THREAD - HIGH SPEED STEEL



STOCK NO.	SIZE	TYPE
OSG10236	6-32	TAPER
OSG10237	6-32	PLUG
OSG10238	6-32	BOTTOM
OSG10242	8-32	TAPER
OSG10243	8-32	PLUG
OSG10244	8-32	BOTTOM
OSG10248	10-24	TAPER
OSG10249	10-24	PLUG
OSG10250	10-24	BOTTOM
OSG10251	10-32	TAPER
OSG10252	10-32	PLUG
OSG10253	10-32	BOTTOM
OSG11200	1/4-20	TAPER
OSG11201	1/4-20	PLUG
OSG11202	1/4-20	BOTTOM
OSG11206	5/16-18	TAPER
OSG11207	5/16-18	PLUG
OSG11208	5/16-18	BOTTOM
OSG11212	3/8-16	TAPER
OSG11213	3/8-16	PLUG
OSG11214	3/8-16	BOTTOM
OSG11224	1/2-13	TAPER
OSG11225	1/2-13	PLUG
OSG11226	1/2-13	BOTTOM
OSG11236	5/8-11	TAPER
OSG11237	5/8-11	PLUG
OSG11238	5/8-11	BOTTOM
OSG11248	3/4-10	TAPER
OSG11249	3/4-10	PLUG
OSG11250	3/4-10	BOTTOM
OSG11354	7/8-9	TAPER
OSG11355	7/8-9	PLUG
OSG11356	7/8-9	BOTTOM
OSG11360	1"-8	TAPER
OSG11361	1"-8	PLUG
OSG11362	1"-8	BOTTOM
OSG11376	1-1/4-7	PLUG
OSG11388	1-1/2-6	PLUG

**8 PITCH PLUG TAPS**

STOCK NO.	SIZE
OSG16901	1-1/8-8
OSG16904	1-1/4-8
OSG16910	1-1/2-8
DTER6013208*	1-1/2-8
STC8148081*	1-3/4-8
STC8200081*	2"-8

\*ECONOMY

ADDITIONAL TAPS AVAILABLE UPON REQUEST



**TYPES**

**TAPER-** HAVE 8 to 10 THREADS CHAMFERED, AND ARE DESIGNED FOR THREADING THROUGH HOLES.

**PLUG-** HAVE 3 to 5 THREADS CHAMFERED, AND ARE MOST WIDELY USED IN THROUGH HOLES AND IN BLIND HOLES THAT DO NOT HAVE TO BE THREADED ALL THE WAY TO THE BOTTOM.

**BOTTOM-** HAVE 1 to 2 THREADS CHAMFERED AND ARE DESIGNED TO THREAD BLIND HOLES ALL THE WAY TO THE BOTTOM.

AVAILABLE FROM SINGLE UNITS TO PACK QUANTITIES.



**THIS SPACE RESERVED FOR FUTURE TAPS**



**SPIRAL-POINT TAPS**  
GROUND THREAD - HIGH SPEED STEEL



STOCK NO.	SIZE	TYPE
-	4-40	PLUG
OSG12124	6-32	PLUG
OSG12125	6-32	BOTTOM
OSG12128	8-32	PLUG
OSG12129	8-32	BOTTOM
OSG12134	10-24	PLUG
OSG12135	10-24	BOTTOM
OSG12138	10-32	PLUG
OSG12139	10-32	BOTTOM
OSG12300	1/4-20	PLUG
OSG12301	1/4-20	BOTTOM
OSG12302*	1/4-20	PLUG
OSG12308	5/16-18	PLUG
OSG12309	5/16-18	BOTTOM
OSG12316	3/8-16	PLUG
OSG12317	3/8-16	BOTTOM
OSG12324	1/2-13	PLUG
OSG12332	5/8-11	PLUG
OSG12336	3/4-10	PLUG

\*3 FLUTE

**NPT PIPE TAPS**  
HIGH SPEED STEEL



STOCK NO.	SIZE
OSG13101	1/8-27
OSG13103	1/4-18
OSG13104	3/8-18
OSG13105	1/2-14
OSG13106	3/4-14

**NPTF (DRYSEAL) PIPE TAPS**  
HIGH SPEED STEEL

STOCK NO.	SIZE
13126	1/8-27
OSG13128	1/4-18
OSG13129	3/8-18
OSG13130	1/2-14
VT385471*	1/2-14
OSG13131	3/4-14
13132	1"-11-1/2

\*VERMONT BRAND

ADDITIONAL TAPS AVAILABLE UPON REQUEST





SPECIALTY AND METRIC TAPS



HI-HELIX PLUG TAPS  
HIGH SPEED STEEL



RECOMMENDED FOR TAPPING RELATIVELY DEEP, BLIND HOLES IN MATERIALS WHICH PRODUCE LONG, CURLING CHIPS. THE HIGHER FLUTE ANGLE INCREASES THE LIFTING ACTION.

STOCK NO.	SIZE	FLUTE
OSG14064	4-40	2
OSG14124	6-32	2
OSG14128	8-32	3
OSG14132	10-24	3
OSG14134	10-32	3
-	12-24	3
OSG14300	1/4-20	3
-	1/4-28	3
OSG14304	5/16-18	3
-	5/16-24	3
OSG14308	3/8-16	3
OSG14320	1/2-13	3

SPIRAL POINT PLUG EXOTAPS  
GROUND THREAD  
PREMIUM HIGH SPEED STEEL



EXOTAP VA3 IS A SUPER ALLOY TAP FOR STAINLESS STEEL. DEVELOPED TO WITHSTAND THE HIGH STRESSES AND HIGH HEAT GENERATED WHEN WORKING STAINLESS MATERIALS.

STOCK NO.	SIZE	FLUTE
17302	6-32	2
OSG17304	10-24	3
OSG17305	10-32	3
OSG17306	1/4-20	3
OSG17308	5/16-18	3
OSG17310	3/8-16	3
OSG17314	1/2-13	3
OSG17316	5/8-11	3
OSG17318	3/4-10	3

HY-PRO SPIRAL POINT PLUG  
GROUND THREAD  
PREMIUM HIGH SPEED STEEL



SPIRAL POINTED TAPS ARE DESIGNED FOR TAPPING HARDENED STEEL SUCH AS 4140, 4340, H-13, D-2, AND 1055 UP TO HRC 35 AS WELL AS A VARIETY OF STAINLESS STEEL.

STOCK NO.	SIZE
OSG28300	1/4-20
OSG28308	5/16-18
OSG28316	3/8-16
OSG28324	1/2-13
OSG28332	5/8-11
OSG28336	3/4-10
OSG28440	7/8-9
OSG28444	1" -8

NPT INTERRUPTED THREAD  
TAPER PIPE TAPS



THESE TAPS HAVE EVERY OTHER THREAD REMOVED EXCEPT FOR THE FIRST FEW AT THE POINT. USED ON TOUGH METALS OR ONES WHICH TEND TO "LOAD" THE TEETH. USE ONLY WHEN REGULAR PIPE TAPS FAIL.

STOCK NO.	SIZE
-	1/8
OSG13153	1/4
OSG13154	3/8
OSG13155	1/2
-	3/4

NPT PIPE TAPS FOR MOLD STEEL



EXOTAP MOLD CONTAINS PREMIUM COBALT AND IS DESIGNED FOR USE IN DIE MOLD STEEL OR ANY PRE-HARDENED STEELS IN THE 30 TO 40 ROCKWELL C RANGE. 4 FLUTES.

STOCK NO.	SIZE
OSG17361	1/4
OSG17362	3/8
OSG17363	1/2

SPECIAL THREAD TAPS



HIGH SPEED STEEL - PLUG STYLE

LEFT-HAND PLUG TAPS  
HIGH SPEED STEEL



STOCK NO.	SIZE
DTER5291024	10-24
STC9010321	10-32
DTER52420	1/4-20
DTER52428	1/4-28
DTER52518	5/16-18
DTER52524	5/16-24
DTER52616	3/8-16
DTER52624	3/8-24
STC9028141	7/16-14
STC9028201	7/16-20
DTER52813	1/2-13
DTER52820	1/2-20
DTER521011	5/8-11
DTER521018	5/8-18
DTER521210	3/4-10
DTER521216	3/4-16

STOCK NO.	SIZE
STC8016241	1/4-24
STC8016321	1/4-32
STC8016361	1/4-36
STC8020321	5/16-32
STC8020361	5/16-36
STC8020401	5/16-40
STC8024321	3/8-32
STC8032241	1/2-24
STC8032281	1/2-28
STC8032321	1/2-32
STC8040161	5/8-16
STC8040241	5/8-24
STC8040261	5/8-26
STC8040281	5/8-28
STC8040321	5/8-32
STC8040361	5/8-36
STC8048241	3/4-24
STC8048261	3/4-26
STC8048281	3/4-28
STC8048321	3/4-32
STC8048361	3/4-36
DTER6005618	7/8-18
WID101	1-3/4-6

HY-PRO THREAD FORMING TAP



HY-PRO NRT FORMING TAPS ARE DESIGNED FOR BETTER AND MORE ECONOMICAL TAPPING OF DUCTILE METALS. THEY ARE IDEAL FOR ALUMINUM, BRASS, COPPER, DIE CASTING, LEADED STEELS, MAGNESIUM, ZINC AND 300 SERIES STAINLESS STEELS UP TO 30 HRC. THE THREADS ARE FORMED BY DISPLACEMENT OF THE MATERIAL WHERE NO CHIPS ARE PRODUCED, AND THE ACCURACY OF THE THREAD IS SUPERIOR TO CONVENTIONAL TAPPING. HY-PRO NRT TAPS ARE DESIGNED FOR HIGH PRODUCTION TAPPING. TAP MATERIAL IS MADE OUT OF HIGH SPEED STEEL COBALT M42.

STOCK NO.	SIZE
OSG14001059	4-40
OSG14001100	6-32
OSG14001152	8-32
OSG14001191	10-24
OSG14001212	10-32

**OUR  
COURTEOUS  
STAFF  
IS READY TO  
TAKE YOUR CALLS.  
IT IS OUR  
PLEASURE TO  
ASSIST YOU.**

CALL US FOR ALL YOUR NEEDS  
**855-785-TOOL**



**METRIC TAPS**



**METRIC HAND TAPS**



GROUND THREAD - HIGH SPEED STEEL

STOCK NO.	SIZE	TYPE
OSG19010	M3 x 0.5	PLUG
OSG19015	M4 x 0.7	TAPER
OSG19016	M4 x 0.7	PLUG
OSG19017	M4 x 0.7	BOTTOM
OSG19022	M5 x 0.8	PLUG
OSG19124	M6 x 1.0	TAPER
OSG19125	M6 x 1.0	PLUG
OSG19126	M6 x 1.0	BOTTOM
OSG19230	M8 x 1.25	TAPER
OSG19231	M8 x 1.25	PLUG
OSG19232	M8 x 1.25	BOTTOM
OSG19236	M10 x 1.5	TAPER
OSG19237	M10 x 1.5	PLUG
OSG19238	M10 x 1.5	BOTTOM
OSG19342	M12 x 1.75	TAPER
OSG19343	M12 x 1.75	PLUG
OSG19344	M12 x 1.75	BOTTOM
VT328752	M14 x 2.0	TAPER
VT328760	M14 x 2.0	PLUG
VT328778	M14 x 2.0	BOTTOM
VT328810	M16 x 2.0	TAPER
VT328828	M16 x 2.0	PLUG
VT328836	M16 x 2.0	BOTTOM
VT328877	M18 x 2.5	TAPER
VT328885	M18 x 2.5	PLUG
VT328893	M18 x 2.5	BOTTOM
VT328935	M20 x 2.5	TAPER
VT328943	M20 x 2.5	PLUG
VT328950	M20 x 2.5	BOTTOM
DTEP5027803*	M22 x 2.5	PLUG
VT329057	M24 x 3.0	TAPER
VT329065	M24 x 3.0	PLUG
VT329073	M24 x 3.0	BOTTOM
VT329180	M30 x 3.5	PLUG

\*ECONOMY

**METRIC TAP SETS**



SETS CONTAIN 1 (ONE) EACH OF THE ABOVE

STOCK NO.	SIZE
VT174519	M3 x 0.5
VT174520	M4 x 0.7
VT174521	M5 x 0.8
VT174522	M6 x 1.0
VT174524	M8 x 1.25
VT174548	M10 x 1.5
VT174549	M12 x 1.75

**ECONOMY-GRADE FINE THREAD METRIC PLUG TAPS**



STOCK NO.	SIZE
DTEP5027745	M7 x 1.00
DTEP5027753	M8 x 1.00
STC1001001	M10 x 1.00
DTEP5027761	M10 x 1.25
STC1101001	M11 x 1.00
STC1101501	M11 x 1.50
STC1201001	M12 x 1.00
DTEP5027769	M12 x 1.25
DTEP5040120	M12 x 1.50
STC1401251	M14 x 1.25
DTEP5027777	M14 x 1.50
DTEP5040160	M16 x 1.25
DTEP5027785	M16 x 1.50
STC1801001	M18 x 1.00
STC1801501	M18 x 1.50
STC2001501	M20 x 1.50
STC2401501	M24 x 1.50
STC2402001	M24 x 2.00
STC3001501	M30 x 1.5
STC3002001	M30 x 2.0

**METRIC SPIRAL POINT PLUG TAPS**



STOCK NO.	SIZE	FLUTES
VT360805	M3 x 0.5	2
OSG19804	M4 x 0.7	2
VT360839	M4 x 0.7	2
OSG19807	M5 x 0.8	2
VT350862	M5 x 0.8	2
OSG19810	M6 x 1.0	2
VT360888	M6 x 1.0	2
OSG19813	M8 x 1.25	2
OSG11012007	M8 x 1.25 +.005	2
VT360920	M8 x 1.25	2
OSG19816	M10 x 1.5	3
VT360946	M10 x 1.5	3
OSG19819	M12 x 1.75	3
VT360961	M12 x 1.75	3
OSG19831	M14 x 2.0	3
OSG19833	M16 x 2.0	3
OSG19835	M18 x 2.5	3
OSG19837	M20 x 2.5	3



**THIS VALUABLE CATALOG IS YOUR GUIDE TO EFFICIENT BUYING**





**HANSON.**

**DIES**

**HANSON.**

**CARBON HEXAGON DIES**



**FRACTIONAL**

STOCK NO.	SIZE	HEX
HAN6412	4-40	1"
HAN6418	6-32	1"
HAN6424	8-32	1"
HAN6428	10-24	1"
HAN6431	10-32	1"
HAN6432	12-24	1"
HAN6520	1/4-20	1"
HAN6523	1/4-28	1"
HAN6527	5/16-18	1"
HAN6529	5/16-24	1"
HAN6534	3/8-16	1"
HAN6536	3/8-24	1"
HAN6539	7/16-14	1"
HAN6540	7/16-20	1"
HAN6544	1/2-13	1"
HAN6545	1/2-20	1"
HAN6848	9/16-12	1-7/16
HAN6849	9/16-18	1-7/16
HAN6852	5/8-11	1-7/16
HAN6854	5/8-18	1-7/16
HAN6858	3/4-10	1-7/16
HAN6860	3/4-16	1-7/16
HAN8461	7/8-9	1-13/16
HAN8463	7/8-14	1-13/16
HAN8465	1"-8	1-13/16
MAG95772	1"-12	1-13/16
HAN8467	1"-14	1-13/16

**METRIC**

STOCK NO.	SIZE	HEX
HAN6612	M3 x .50	1"
HAN6617	M4 x .70	1"
HAN6622	M5 x .80	1"
HAN6627	M6 x 1.00	1"
HAN6633	M8 x 1.00	1"
HAN6634	M8 x 1.25	1"
HAN6638	M10 x 1.00	1"
HAN6639	M10 x 1.25	1"
HAN6640	M10 x 1.50	1"
HAN6642	M12 x 1.25	1"
HAN6643	M12 x 1.50	1"
HAN6644	M12 x 1.75	1"
HAN6949	M14 x 1.25	1-7/16
HAN6950	M14 x 1.50	1-7/16
HAN6952	M14 x 2.00	1-7/16
HAN6955	M16 x 1.50	1-7/16
HAN6956	M16 x 2.00	1-7/16
HAN6959	M18 x 1.50	1-7/16
HAN6961	M18 x 2.50	1-7/16
HAN8564	M20 x 2.50	1-13/16
HAN8568	M24 x 2.00	1-13/16
HAN8569	M24 x 3.00	1-13/16

**NPT CARBON HEXAGON PIPE DIES**

STOCK NO.	SIZE	HEX
HAN6702	1/8	1"
HAN6703	1/4	1"

**ADDITIONAL CARBON HEX DIE SIZES AVAILABLE  
IN BOTH FRACTIONAL AND METRIC  
BY REQUEST**

**ADJUSTABLE ROUND DIES**



**RIGHT-HAND (HIGH SPEED STEEL)**

STOCK NO.	SIZE	O.D.
STC1016201	1/4-20	1"
STC1016281	1/4-28	1"
STC1020181	5/16-18	1"
STC1020241	5/16-24	1"
STC1024161	3/8-16	1"
STC1024241	3/8-24	1"
STC1032131	1/2-13	1"
STC1032201	1/2-20	1"
STC1040112	5/8-11	1-1/2
STC1040182	5/8-18	1-1/2
STC1048102	3/4-10	1-1/2
STC1048162	3/4-16	1-1/2

**LEFT-HAND (HIGH SPEED STEEL)**

STOCK NO.	SIZE	O.D.
DTER621420	1/4-20	1"
DTER621428	1/4-28	1"
DTER6251618	5/16-18	1"
DTER6251624	5/16-24	1"
DTER623816	3/8-16	1"
DTER623824	3/8-24	1"
DTER621213	1/2-13	1"
DTER621220	1/2-20	1"
DTER625811	5/8-11	1-1/2
DTER625818	5/8-18	1-1/2
DTER623410	3/4-10	1-1/2
DTER623416	3/4-16	1-1/2

**CARBON HEX RETHREAD DIES**



(NOT FOR USE IN CUTTING NEW THREADS)

STOCK NO.	SIZE
HAN7220	1/4-20
HAN7223	1/4-28
HAN7227	5/16-18
HAN7229	5/16-24
HAN7234	3/8-16
HAN7236	3/8-24
HAN7239	7/16-14
HAN7240	7/16-20
HAN7244	1/2-13
HAN7245	1/2-20
HAN7248	9/16-12
HAN7249	9/16-18
HAN7252	5/8-11
HAN7254	5/8-18
HAN7257	11/16-16
HAN7258	3/4-10
HAN7260	3/4-16
HAN7261	7/8-9
HAN7263	7/8-14

(CONTINUED NEXT COLUMN)

STOCK NO.	SIZE
HAN7265	1"-8
HAN7266	1"-12
HAN7267	1"-14
HAN7268	1-1/8-7
STC1207208	1-1/8-8
HAN7269	1-1/8-12
HAN7270	1-1/4-7
STC1208008	1-1/4-8
HAN7271	1-1/4-12
HAN7272	1-3/8-6
HAN7273	1-3/8-12
HAN7274	1-1/2-6
STC1209608	1-1/2-8
HAN7275	1-1/2-12
STC1214808	1-3/4-8
STC1220008	2"-8

**NPT CARBON RETHREAD PIPE DIES**

STOCK NO.	SIZE
HAN7403	1/4
HAN7404	3/8
HAN7405	1/2
HAN7406	3/4
HAN7407	1"

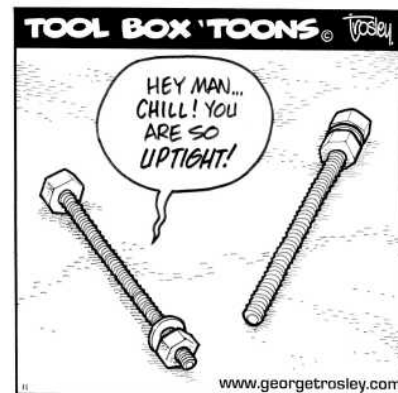

**RETHREADING TOOLS AND SETS**

**UNIVERSAL THREAD RESTORING FILE**



THIS UNIVERSAL THREAD RESTORING FILE PUTS NEW LIFE IN MASHED THREADS OF ALL SIZES AND TYPES. IT'S AN IDEAL TOOL FOR RELIEVING OVERSIZED THREADS THAT FIT TOO TIGHT. RESTORES USS (NC), SAE (NF), METRIC AND FOREIGN THREADS. FILE EDGE LENGTH IS 5". OVERALL LENGTH INCLUDING HANDLE IS 9".

STOCK NO. RIM0039

**EXTERNAL THREAD RESTORING FILE**



RESTORES DAMAGED EXTERNAL THREADS ON STUDS, BOLTS, SCREWS, SHAFTS, PLUMBING PIPE AND PIPE FITTINGS. RESTORES RUSTED OR CORRODED FASTENERS. DOUBLES AS A SCREW PITCH GAUGE. 8-1/2" x 7/16" x 7/16". THREAD PITCH SIZES: 11, 12, 13, 14, 16, 18, 20, 24 T.P.I.

STOCK NO. GEN1771

**RETHREADER DIE SET  
10 PIECE**

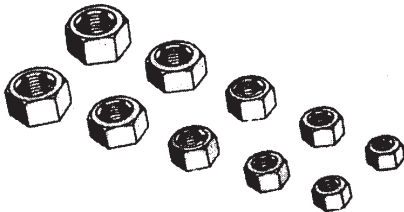

THESE NUT SIZE RETHREADING HEX DIES ARE JUST WHAT IS NEEDED FOR RESTORING DAMAGED THREADS IN TIGHT PLACES. SIZES: 1/4, 5/16, 3/8, 7/16 & 1/2 IN BOTH NC AND NF.

STOCK NO. RIM0710

**METRIC RETHREADER DIE SET  
5 PIECE**

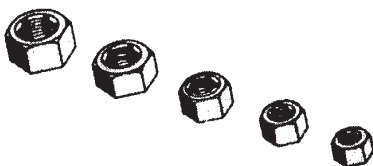

RESTORES DAMAGED THREADS IN TIGHT PLACES. MADE OF THE FINEST HEAT-TREATED STEEL TO CLOSE TOLERANCES WITH FULL THREADS. ALL DIES ARE COUNTERSUNK FOR EASY STARTING. SIZES: 12 x 1.75, 10 x 1.50, 8 x 1.25, 7 x 1.00 & 6 x 1.00 mm.

STOCK NO. RIM0711

**COARSE THREAD RESTORER TAP SET**

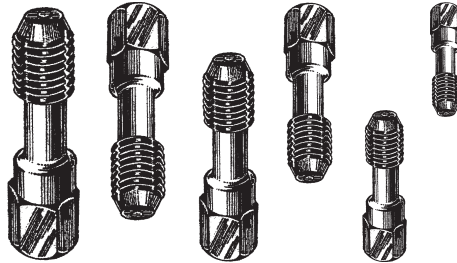

RESTORES DAMAGED THREADS ON 1/4-20, 5/16-18, 3/8-16, 7/16-14, 1/2-13 AND 9/16-12 SIZES WITHOUT UNDERCUTTING. TOOL HAS HEX HEAD FOR EASY DRIVING AND IS PILOTTED FOR EASY STARTING. SIX TAPS PACKED IN A COMPACT PLASTIC POUCH.

STOCK NO. RIM0713

**FINE THREAD RESTORER TAP SET**

SAME AS COARSE THREAD BUT, RESTORES DAMAGED THREADS ON 1/4-28, 5/16-24, 3/8-24, 7/16-20, 1/2-20 AND 9/16-18 SIZES.

STOCK NO. RIM0712

**EXTERNAL/INTERNAL THREAD RESTORING FILES**



RESTORES DAMAGED THREADS FOR ALL POPULAR PIPE THREAD SIZES FOR BOTH EXTERNAL PIPE AND INTERNAL FIXTURE THREADS. ALSO RESTORES DAMAGED THREADS FOR ALL POPULAR BOLT AND NUT THREADS.

STOCK NO.	RESTORES THREADS
WF17250	11, 12, 13, 14, 16, 18, 20, 24
WF17251	.75, 1.00, 1.25, 1.50, 1.75, 2.00, 2.50, 3.00 mm
WF17252	9, 10, 12, 16, 20, 27, 28, 32
WF17253	PIPE THREADS 8, 10, 11-1/2, 14, 16, 18, 24, 27
WF17254	4 PIECE SET INCLUDES ONE EACH OF THE ABOVE

ADDITIONAL ITEMS AVAILABLE UPON REQUEST

**ASSISTANCE  
IS A  
PHONE CALL  
AWAY!**



**CALL US FOR ALL YOUR NEEDS  
855-785-TOOL**

**PLACING AN ORDER?**

THIS VALUABLE CATALOG IS YOUR TOOL FOR EFFICIENT BUYING. CONSULT CATALOG INDEX FOR EASY REFERENCE, AND REFER TO STOCK NUMBERS FOR USER-FRIENDLY ACCESS. IT'S THAT EASY!



**TAP AND DIE ACCESSORIES**



**DIE STOCK**



PLAIN - FOR HEX OR ROUND DIES

STOCK NO.	O.D.	APPLICATION
HAN12008	1"	HEX AND ROUND
DTEV50150	1-1/2"	ROUND ONLY
STC2320020	2"	ROUND ONLY



ADJUSTABLE GUIDE - FOR HEXAGON DIES

STOCK NO.	HAN12436 (1-7/16 W.A.F.)
-----------	--------------------------

**TAP WRENCHES  
 BAR TYPE - ADJUSTABLE**



STOCK NO.	SIZE RANGE
HAN12088	#0 - 1/2"
SKF23972	5/32 - 3/4"
SKF23973	1/4 - 1 1/8"

**T-HANDLE WRENCHES**



STOCK NO.	SIZE RANGE
HAN12401	#0 - 1/4"
HAN12402	1/4 - 1/2"

**13" LONG TAP WRENCHES**



STOCK NO.	SIZE RANGE
STC2335523	1/4 - 1/2"

**ALSO AVAILABLE: 2-IN-1 T-HANDLE WRENCH** HAS A 3/8" SQUARE DRIVE TO ACCOMMODATE SOCKET WRENCH OR EXTENSION WHEN DESIRED.

STOCK NO. HAN12450

**RATCHET-STYLE T-HANDLE WRENCHES**

STOCK NO.	SIZE RANGE
GEN160R	#0 - #8
GEN161R	#8 - 1/4"

**TAP EXTRACTORS**



**4 FLUTE**

STOCK NO.	SIZE
WAL10063*	#6
WAL10084	#8
WAL10104	#10
WAL10124	#12
WAL10254	1/4"
WAL10314	5/16"
WAL10374	3/8"
WAL10434	7/16"
WAL10504	1/2"
WAL10564	9/16"
WAL10624	5/8"
WAL10754	3/4"
WAL10874	7/8"
WAL11004	1"
WAL11124	1-1/8"
WAL11254	1-1/4"

**\*3 FLUTE**

**TAP EXTRACTOR REPLACEMENT FINGERS**

STOCK NO.	SIZE
WAL12084	#8
WAL12104	#10
WAL12254	1/4"
WAL12314	5/16"
WAL12374	3/8"
WAL12434	7/16"
WAL12504	1/2"
WAL12564	9/16"
WAL12624	5/8"
WAL12754	3/4"
WAL13004	1"

**TAP EXTRACTOR SETS**



**#2 SET**

INCLUDES SIZES 1/4, 5/16, 3/8, 7/16, 1/2, 5/8. ALL 4 FLUTE. MOLDED PLASTIC CASE.

STOCK NO. WAL18002

**#13 SET (PICTURED)**

INCLUDES SIZES #4, #5 AND #6 IN 3 FLUTE. #8, #10, #12, 1/4, 5/16, 3/8, 7/16, 1/2, 5/8 AND 3/4 IN 4 FLUTE. MOLDED PLASTIC CASE.

STOCK NO. WAL18013

**PIPE TAP EXTRACTORS**



STOCK NO.	SIZE
WAL20124	1/8"
WAL20254	1/4"
WAL20374	3/8"
WAL20504	1/2"
WAL20755	3/4"
WAL21005	1"

**TAP EXTENSIONS**

STYLE A - FOR HAND TAPPING ONLY



5" LONG EACH

STOCK NO.	SIZE
WAL45010	#10
WAL45025	1/4"
WAL45031	5/16"
WAL45038	3/8"
WAL45043	7/16"
WAL45050	1/2"
WAL45062	5/8"
WAL45075	3/4"

**TAP EXTENSION SET**

STYLE B - FOR MACHINE & HAND TAPPING



8" LONG EACH



TAP IS HELD SECURELY IN THE DEEP SOCKET BY 2 SET SCREWS. SET IS PACKED IN STURDY MOLDED PLASTIC CASE, COMPLETE WITH HEX KEYS AND EXTRA SOCKET SET SCREWS. ONE SIZE EACH: #0 - #6, #8, #10 (3/16), #12, 1/4, 5/16, 3/8, 7/16, 1/2.

STOCK NO. WAL40090

**ADDITIONAL TAP EXTRACTORS, REPLACEMENT FINGERS, TAP EXTENSIONS AND SETS AVAILABLE UPON REQUEST**

# HANSON

## SCREW EXTRACTORS & SETS

# WALTON

### SPIRAL SCREW EXTRACTORS



STOCK NO.	SIZE	STOCK NO.	SIZE
HAN52401	#EX-1	HAN52406	#EX-6
HAN52402	#EX-2	HAN52407	#EX-7
HAN52403	#EX-3	HAN52408	#EX-8
HAN52404	#EX-4	HAN52409	#EX-9
HAN52405	#EX-5	HAN52410	#EX-10

### SPIRAL EXTRACTOR SETS



#### 5 PIECE SET

INCLUDES #EX-1 THROUGH #EX-5 PLASTIC POUCH  
STOCK NO. HAN53535

#### 6 PIECE SET

INCLUDES #EX-1 THROUGH #EX-6 PLASTIC POUCH  
STOCK NO. HAN53545

### BOLT EXTRACTORS



HEXAGONAL FLATS TO USE WITH FLAT WRENCHES, ADJUSTABLE WRENCH OR SOCKET. SQUARE DRIVE FOR USE WITH SOCKET OR IMPACT WRENCH. LEFT HAND SPIRAL FLUTES FOR MAXIMUM GRIPPING POWER. MADE FROM HIGH CARBON STEEL.

STOCK NO.	DESCRIPTION
HAN54009	9 PC. EXTRACTOR SET. 1/4" - 3/4" W/ 3/8" DRIVE.
HAN54019	9 PC. EXTRACTOR SET 8MM - 19MM W/ 3/8" DRIVE
HAN54113	13 PC. EXTRACTOR SET 1/4" - 3/4" W/ 3/8" DRIVE
HAN54125	5 PC. EXTRACTOR SET 3/4" - 1" W/ 1/2' DRIVE

### SCREW EXTRACTOR SELECTOR CHART

#### SPIRAL FLUTE

EX-1	5/16"	3/8" to 1/2", 2.5MM to 4MM, No. 3 to No. 6
EX-2	7/16"	1/2" to 5/8", 4MM to 6MM, No. 6 to No. 12
EX-3	9/16"	5/8" to 3/4", 6MM to 8MM, No. 12
EX-4	1"	3/4" to 1" and 1/2" NPT, 1/2" BSP, 8MM to 10MM
EX-5	1 1/8"	1/2" to 3/4" and 1/2" NPT, 1/2" BSP, 10MM to 16MM
EX-6	1 1/4"	3/4" to 1" and 1/2" NPT, 1/2" BSP, 16MM to 22MM
EX-7	1 1/2"	1/2" to 1 1/4" and 1/2" NPT, 1/2" BSP, 22MM to 27MM
EX-8	1 3/4"	1 1/4" to 1 1/2" and 1/2" NPT, 1/2" BSP, 27MM to 36MM
EX-9	1 7/8"	1 1/4" to 2" and 1" NPT, 1" BSP, 36MM to 52MM
EX-10	1 5/8"	2 1/4" to 2 1/2" and 1 1/2" NPT, 1 1/2" BSP, 52MM to 68MM

#### STRAIGHT FLUTE

ST-1	3/16"	3/16" to 3/16", 5MM to 8MM, No. 10
ST-2	3/16"	3/8", 10MM
ST-3	1/4"	7/16" and 1/2" NPT, 10MM, 1/2" BSP
ST-4	3/16"	1/2" to 3/4" and 1/2" NPT, 12MM to 14MM, 1/2" BSP
ST-5	3/8"	5/8" and 3/4" NPT, 16MM, 3/8" BSP
ST-6	1/2"	3/4" and 1/2" NPT, 20MM, 1/2" BSP
ST-7	3/4"	7/8", 22MM, 3/4" BSP

### STRAIGHT SCREW EXTRACTORS



STOCK NO. SIZE

HAN52601	#ST-1
HAN52602	#ST-2
HAN52603	#ST-3
HAN52604	#ST-4
HAN52605	#ST-5
HAN52606	#ST-6
-	#ST-7

### STRAIGHT EXTRACTOR SET



#### 5 PIECE SET

INCLUDES #ST-1 THROUGH #ST-5 PLASTIC POUCH

STOCK NO. HAN53635

ADDITIONAL WALTON ITEMS AVAILABLE UPON REQUEST

### HEAVY-DUTY EXTRACTOR SETS FOR PIPE, STUDS AND SCREWS



"REPS" HEAVY-DUTY EXTRACTORS HAVE A FOUR POINT SHALLOW GRIP, WHICH ASSURES A STRONG BITE (WITH LESS EXPANSION AND JAMMING). SETS ARE PACKED IN DURABLE MOLDED PLASTIC CASES.



#### 5 PIECE SET

INCLUDES ONE EACH OF #1, #2, #3, #4, #5. RANGE FOR BROKEN PIPE: 1/8 - 3/4 FOR BROKEN STUD OR SCREW: 3/8 - 1-1/8

STOCK NO. WAL50205

#### 6 PIECE SET

INCLUDES ONE EACH OF #1, #2, #3, #4, #5, #6. RANGE FOR BROKEN PIPE: 1/8 - 1" FOR BROKEN STUD OR SCREW: 3/8 - 1-1/2 or 1-3/4.

STOCK NO. WAL50206

#### 7 PIECE SET (PICTURED)

INCLUDES ONE EACH OF #1, #2, #3, #4, #5, #6, #7. RANGE FOR BROKEN PIPE: 1/8 - 1-1/4 FOR BROKEN STUD OR SCREW: 3/8 - 2"

STOCK NO. WAL50207

ADDITIONAL WALTON ITEMS AVAILABLE UPON REQUEST



REAMERS AND COUNTERSINKS



STRAIGHT-FLUTE  
CHUCKING REAMER



HSS- 45° CHAMFER - R.H. CUT

STOCK NO.	DIAMETER	OVERALL LENGTH
SKF160118	1/8	3-1/2
SKF1601964	9/64	4"
SKF1601532	5/32	4"
SKF16011164	11/64	4-1/2
SKF1601316	3/16	4-1/2
SKF16011364	13/64	5"
SKF1601732	7/32	5"
SKF16011564	15/64	6"
SKF160114	1/4	6"
SKF16011764	17/64	6"
SKF1601932	9/32	6"
SKF16011964	19/64	6"
SKF1601516	5/16	6"
SKF16012164	21/64	6"
SKF16011132	11/32	6"
SKF16012364	23/64	7"
SKF160138	3/8	7"
SKF16012564	25/64	7"
SKF16011332	13/32	7"
SKF16012764	27/64	7"
SKF1601716	7/16	7"
SKF16012964	29/64	7"
SKF16011532	15/32	7"
SKF16013164	31/64	8"
SKF160112	1/2	8"
SKF16011732	17/32	8"
SKF1601916	9/16	8"
SKF16011932	19/32	8"
SKF160158	5/8	9"
SKF16012132	21/32	9"
SKF16011116	11/16	9"
SKF16012332	23/32	9"
SKF160134	3/4	9-1/2
SKF16012532	25/32	9-1/2
SKF16011316	13/16	9-1/2
SKF16012732	27/32	9-1/2
SKF160178	7/8	10"
SKF16012932	29/32	10"
SKF16011516	15/16	10"
SKF16013132	31/32	10"
SKF16011	1"	10-1/2
SKF160111160	1-1/16	10-1/2
SKF1601118	1-1/8	11"
SKF160113160	1-3/16	11"
SKF1601114	1-1/4	11-1/2

SPIRAL FLUTE CAR REAMERS



THESE REAMERS ARE ESPECIALLY DESIGNED FOR THE REAMING OF STRUCTURAL STEEL PLATE. FOR USE ONLY TO ENLARGE PREVIOUSLY DRILLED OR FORMED HOLES.

HSS - 1/2" DIA. REDUCED SHANKS - R.H. CUT

STOCK NO.	DIAMETER	OVERALL LENGTH
CD06400	1/2	5-7/8
CD06410	9/16	5-7/8
CD06420	5/8	6-3/8
CD06430	11/16	6-3/8
CD06440	3/4	6-7/8
CD06460	7/8	6-7/8
CD06480	1"	6-7/8

SPIRAL-FLUTE  
HAND REAMERS



HSS- 45° CHAMFER - L.H. HELICAL FLUTE

STOCK NO.	DIAMETER	OVERALL LENGTH
SKF161314	1/4	4"
SKF1613516	5/16	4-1/2
SKF161338	3/8	5"
SKF1613716	7/16	5-1/2
SKF161312	1/2	6"
SKF1613916	9/16	61/2
SKF161358	5/8	7"
-	11/16	7-3/4
SKF161334	3/4	8-3/8
SKF161378	7/8	9-3/4
SKF16131516	15/16	10-1/4
SKF16131	1"	10-7/8
DTBM51116	1-1/4	11"

STRAIGHT-FLUTE  
TAPER PIN REAMERS



HIGH SPEED STEEL

STOCK NO.	SIZE	OVERALL LENGTH
STC1155000	#0	2-15/16
STC1155001	#1	2-15/16
STC1155002	#2	3-3/16
STC1155003	#3	3-11/16
STC1155004	#4	4-1/16
STC1155005	#5	4-5/16
STC1155006	#6	5-7/16
STC1155007	#7	6-5/16
STC1155008	#8	7-3/16
STC1155009	#9	8-5/16
STC1155010	#10	9-5/16

REPAIR REAMERS



REMOVABLE  
HANDLE WITH 3/8"  
SQUARE DRIVE.

STOCK NO. HAN11214 (1/8" - 1/2")  
STOCK NO. HAN11221 (1/2" - 1")

COMBINED DRILLS & COUNTERSINKS



HIGH SPEED STEEL - 118° POINT

STOCK NO.	SIZE	DRILL DIA.	BODY DIA.
SKF02751	#1	3/64	1/8
SKF02752	#2	5/64	3/16
SKF02753	#3	7/64	1/4
SKF02754	#4	1/8	5/16
SKF02755	#5	3/16	7/16
SKF02756	#6	7/32	1/2
SKF02757	#7	1/4	5/8
SKF02758	#8	5/16	3/4

LONG LENGTH COMB. DRILLS &



STOCK NO.	CTS SKS SIZE	DRILL DIA.	BODY DIA.
SKF02771X4	#1 x 4"	3/64	1/8
SKF02772X4	#2 x 4"	5/64	3/16
SKF02773X5	#3 x 5"	7/64	1/4
SKF02774X5	#4 x 5"	1/8	5/16
SKF02775X5	#5 x 5"	3/16	7/16
SKF02776X5	#6 x 5"	7/32	1/2

SINGLE-FLUTE COUNTERSINKS



CHAMPION  
CUTTING TOOL CORP.  
82°  
HIGH HOOK

STOCK NO.	SIZE	STOCK NO.	SIZE
CHPXL80114	1/4	CHPXL80134	3/4
CHPXL80138	3/8	CHPXL8011	1"
CHPXL80112	1/2	CHPXL801114	1-1/4
CHPXL80158	5/8	DTBC52RF24	1-1/2

90° COUNTERSINKS  
FOR USE ON METRIC FLAT HEAD SCREWS

STOCK NO.	SIZE	STOCK NO.	SIZE
CHPXL8011490	1/4	CHPXL8015890	5/8
CHPXL8013890	3/8	CHPXL8013490	3/4
CHPXL8011290	1/2		

CAPSCREW COUNTERBORES  
3 FLUTE - STRAIGHT SHANK - HSS - SOLID PILOT



STOCK NO.	SOCKET CAP SIZE	PILOT DIA.	CUTTING DIA.
DTCD50008	#8	11/64	19/64
DTCD50010	#10	13/64	21/64
DTCD50016	1/4	9/32	13/32
DTCD50020	5/16	11/32	1/2
DTCD50024	3/8	13/32	19/32
DTCD50032	1/2	17/32	25/32

DEBURRING BLADES AND TOOL



**B10**-BASIC HSS BLADE USED FOR STEEL/ALUMINUM.  
**B20**-HSS BLADE USED FOR BRASS AND CAST IRON CAN ROTATE CLOCKWISE AND COUNTERCLOCK WISE.  
**B30**- REMOVES INTERNAL AND EXTERNAL BURRS SIMULTANEOUSLY FROM HOLES DRILLED INTO TUBING AND SHEET METAL.

SOLD PER EACH OR FIVE PACK

STOCK NO.	DTFN50B10 (B10)	OTHER BLADE STYLES AVAILABLE
STOCK NO. DTFN50B10P(B10)		
STOCK NO. DTFN50B20 (B20)		
STOCK NO. DTFN50B30 (B30)		

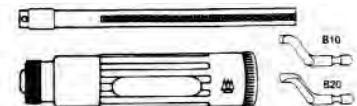

TOOL COMES WITH HANDLE AND TWO BLADES.  
STOCK NO. DTFN50PBB2

## END MILLS

### ROUGHING END MILLS

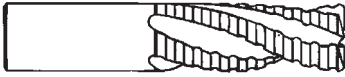

#### PREMIUM HSS - 8% COBALT

STOCK NO.	MILL DIA.	LENGTH OF CUT	OVERALL LENGTH	NO. OF FLUTES
OSG49099	7/16	1"	2-11/16	4
OSG49001	1/2	1-1/4	3-1/4	4
OSG49005	5/8	1-5/8	3-3/4	4
OSG49013	3/4	1-5/8	3-7/8	4
OSG49017	7/8	1-7/8	4-1/8	5
OSG49101*	1"	2"	4-1/4	5
OSG49105	1"	2"	4-1/2	5
OSG49121	1-1/4	2"	4-1/2	6
OSG49135	1-1/2	3"	5-1/2	6
OSG49201	2"	2"	4-1/2	8
OSG49205	2"	4"	6-1/2	8

\* 3/4 SHANK

#### FINE PITCH ROUGHING ENDMILLS

STOCK NO.	MILL DIA.	LENGTH OF CUT	OVERALL LENGTH	NO. OF FLUTES
OSG45098	3/8	1-1/2	3-1/4	4
OSG45003	1/2	2"	4"	4
OSG45007	5/8	2-1/2	4-5/8	4
OSG45015	3/4	3"	5-1/4	4
OSG45109	1"	4"	6-1/2	5

#### EXTRA-LONG ROUGHING ENDMILLS

STOCK NO.	MILL DIA.	LENGTH OF CUT	OVERALL LENGTH	NO. OF FLUTES
OSG49092	1/4	1-1/4	3-1/16	4
OSG49098	3/8	1-1/2	3-1/4	4
OSG49003	1/2	2"	4"	4
OSG49007	5/8	2-1/2	4-5/8	4
OSG49015	3/4	3"	5-1/4	4
OSG49107	1"	3"	5-1/2	5
OSG49109	1"	4"	6-1/2	5
OSG49123	1-1/4	3"	5-1/2	6
OSG49137	1-1/2	4"	6-1/2	6

### SINGLE-END 2-FLUTE END MILLS



#### PREMIUM HSS - 8% COBALT

STOCK NO.	MILL DIA.	LENGTH OF CUT	OVERALL LENGTH
OSG52001	1/8	3/8	2-5/16
OSG52091	5/32	7/16	2-5/16
OSG52002	3/16	7/16	2-5/16
OSG52092	7/32	1/2	2-5/16
OSG52003	1/4	1/2	2-5/16
OSG52093	9/32	9/16	2-5/16
OSG52004	5/16	7/16	2-5/16
OSG52094	11/32	9/16	2-5/16
OSG52005	3/8	9/16	2-5/16
OSG52095	13/32	13/16	2-1/2
OSG52006	7/16	13/16	2-1/2
OSG52097	15/32	13/16	2-1/2
OSG52011	1/2	1"	3"
OSG52016	17/32	1-1/8	3-1/8
OSG52012	9/16	1-1/8	3-1/8

(CONTINUED NEXT COLUMN)

### SINGLE-END 2-FLUTE END MILLS

STOCK NO.	MILL DIA.	LENGTH OF CUT	OVERALL LENGTH
OSG52017	19/32	1-1/8	3-1/8
OSG52021	5/8	1-5/16	3-7/16
OSG52018	21/32	1-5/16	3-5/16
OSG52022	11/16	1-5/16	3-7/16
OSG52019	23/32	1-5/16	3-5/16
OSG52023	3/4	1-5/16	3-7/16
OSG52031	3/4	1-5/16	3-9/16
OSG52028	25/32	1-1/2	3-5/8
OSG52024	13/16	1-1/2	3-5/8
OSG52029	27/32	1-1/2	3-5/8
OSG52032	7/8	1-1/2	3-3/4
OSG52034	29/32	1-1/2	3-3/4
OSG52026	15/16	1-1/2	3-5/8
OSG52035	31/32	1-1/2	3-3/4
OSG52033	1"	1-1/2	3-3/4
OSG52052	1-1/8	1-5/8	4-1/8
OSG52053	1-1/4	1-5/8	4-1/8
OSG52054	1-3/8	1-5/8	4-1/8
OSG52055	1-1/2	1-5/8	4-1/8
OSG52063	1-3/4	1-5/8	4-1/8

### BALL-END END MILLS



#### SINGLE-END 2-FLUTE PREMIUM HSS - 8% COBALT

STOCK NO.	MILL DIA.	LENGTH OF CUT	OVERALL LENGTH
OSG52101	1/8	3/8	2-5/16
OSG52102	3/16	1/2	2-3/8
OSG52103	1/4	5/8	2-7/16
OSG52104	5/16	3/4	2-1/2
OSG52105	3/8	3/4	2-1/2
OSG52196	7/16	1"	3"
OSG52111	1/2	1"	3"
OSG52113	5/8	1-1/8	3-1/8 *
OSG52115	3/4	1-5/16	3-5/16
OSG52133	1"	2-1/4	4-1/2

\*1/2 SHANK

### DOUBLE-END 2-FLUTE END MILLS

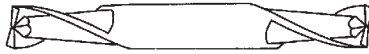

#### PREMIUM HSS - 8% COBALT

STOCK NO.	MILL DIA.	LENGTH OF CUT	OVERALL LENGTH
OSG52201	1/8	3/8	3-1/16
OSG52291	5/32	7/16	3-1/8
OSG52202	3/16	3/8	3-1/8
OSG52292	7/32	1/2	3-1/8
OSG52203	1/4	1/2	3-1/8
OSG52204	5/16	3/8	3-1/8
OSG52205	3/8	3/8	3-1/8
OSG52296	7/16	13/16	3-3/4
OSG52211	1/2	13/16	3-3/4
OSG52221	5/8	1-1/8	4-1/2
OSG52231	3/4	1-5/16	5"
OSG52241	7/8	1-9/16	5-1/2

### DOUBLE-END 4-FLUTE END MILLS

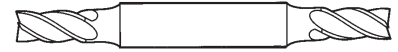

#### PREMIUM HSS - 8% COBALT

STOCK NO.	MILL DIA.	LENGTH OF CUT	OVERALL LENGTH
OSG54201	1/8	3/8	3-1/16
OSG54202	3/16	1/2	3-1/4
OSG54203	1/4	5/8	3-3/8
OSG54204	5/16	3/4	3-1/2
OSG54205	3/8	3/4	3-1/2
OSG54211	1/2	1"	4-1/8
OSG54221	5/8	1-3/8	5"
OSG54231	3/4	1-5/8	5-5/8

### DOUBLE-END 4-FLUTE END MILLS CENTER CUTTING



#### PREMIUM HSS - 8% COBALT

STOCK NO.	MILL DIA.	LENGTH OF CUT	OVERALL LENGTH
OSG54301	1/8	3/8	3-1/16
OSG54302	3/16	1/2	3-1/4
OSG54303	1/4	5/8	3-3/8
OSG54304	5/16	3/4	3-1/2
OSG54305	3/8	3/4	3-1/2
OSG54311	1/2	1	4-1/8
OSG54321	5/8	1-3/8	5"
OSG54331	3/4	1-5/8	5-5/8
54341	7/8	1-7/8	6-1/8
54351	1	1-7/8	6-3/8

### SINGLE-END MULTIPLE FLUTE END MILLS



#### PREMIUM HSS - 8% COBALT

STOCK NO.	MILL DIA.	LENGTH OF CUT	OVERALL LENGTH	NO. OF FLUTES
OSG54001	1/8	3/8	2-5/16	4
OSG54002	3/16	1/2	2-3/8	4
OSG54003	1/4	5/8	2-7/16	4
OSG54004	5/16	3/4	2-1/2	4
OSG54005	3/8	3/4	3-1/2	4
OSG54006	7/16	1"	2-11/16	4
OSG54011	1/2	1-1/4	3-1/4	4
OSG54012	9/16	1-3/8	3-3/8	4
OSG54021	5/8	1-5/8	3-1/4	4
OSG54022	11/16	1-5/8	3-3/4	4
OSG54031	3/4	1-5/8	3-7/8	4
OSG54032	7/8	1-7/8	4-1/8	4
OSG54033	1"	1-7/8	4-1/8	4
OSG54053	1-1/4	2"	4-1/2	6
OSG54055	1-1/2	2"	4-1/2	6
OSG54064	2"	2"	4-1/2	8

**END MILLS**

**LONG LENGTH END MILLS**



**SINGLE-END - PREMIUM HSS - 8% COBALT**

STOCK NO.	MILL DIA.	LENGTH OF CUT	OVERALL LENGTH	NO. OF FLUTES
OSG54503	1/4	1-1/4	3-1/16	4
OSG54504	5/16	1-3/8	3-1/8	4
OSG54505	3/8	1-1/2	3-1/4	4
OSG54510	7/16	1-3/4	3-3/4	4
OSG54511	1/2	2"	4"	4
OSG54521	5/8	2-1/2	4-5/8	4
OSG54531	3/4	3"	5-1/4	4
OSG54541	7/8	3-1/2	5-3/4	4
OSG54551	1"	4"	6-1/2	4
OSG54561	1-1/4	4"	6-1/2	6

**EXTRA-LONG LENGTH END MILLS**



**SINGLE-END - 4-FLUTE  
PREMIUM HSS - 8% COBALT**

STOCK NO.	MILL DIA.	LENGTH OF CUT	OVERALL LENGTH
OSG55703	1/4	1-3/4	3-9/16
OSG55704	5/16	2"	3-3/4
OSG55705	3/8	2-1/2	4-1/4
OSG55711	1/2	3"	5"
OSG55721	5/8	4"	6-1/8
OSG55731	3/4	4"	6-1/4
OSG55751	1"	6"	8-1/2

**MINIATURE END MILLS**



**DOUBLE-END - 4-FLUTE  
PREMIUM HSS - 8% COBALT  
3/16" DIAMETER STRAIGHT SHANKS**

STOCK NO.	MILL DIA.	LENGTH OF CUT	OVERALL LENGTH
OSG56672	1/16	3/32	2"
OSG56674	3/32	9/64	2"
OSG56676	1/8	3/16	2"
OSG56776	1/8	3/8	2-1/4
OSG56680	3/16	9/32	2"
OSG56780	3/16	1/2	2-1/4

**TAPERED END MILL**



**10° TAPER ON SIDE  
THREE FLUTE - CENTER CUTTING**

STOCK NO.	MILL DIA.	LENGTH OF CUT	OVERALL LENGTH
OSG59761	1/4	3/4	2-3/4

**METRIC END MILLS**



**SINGLE-END - PREMIUM HSS - 8% COBALT**

STOCK NO.	MILL DIA.	LENGTH OF CUT	OVERALL LENGTH	NO. OF FLUTES
OSG58002	M4	7/16	2-5/16	2
OSG58003	M5	1/2	2-5/16	2
OSG58004	M6	1/2	2-5/16	2
OSG58104	M6	5/8	2-7/16	4
OSG58006	M8	9/16	2-5/16	2
OSG58106	M8	3/4	2-1/2	4
OSG58008	M10	13/16	2-1/2	2
OSG58108	M10	3/4	2-1/2	4
OSG58011	M12	1"	3"	2
OSG58013	M14	1-1/8	3-1/8	2
OSG58021	M16	1-5/16	3-7/16	2
OSG58023	M18	1-5/16	3-7/16	2
OSG58032	M20	1-1/2	3-3/4	2

**EXOMILLS**

DELIVER COST-SAVING BENEFITS ON TOUGH-TO-MILL APPLICATIONS: ST. STEEL, TITANIUM, AND HEAT RESISTANT-ALLOYS. MADE UP OF PREM.-GRADE HIGH SPEED STEEL. LASTS MUCH LONGER THAN REGULAR HSS AND COBALT END MILLS BECAUSE THEY WITHSTAND HIGHER CUTTING TEMP. LESS WEAR DUE TO THEIR HARDNESS AND ABILITY TO WITHSTAND ABRASION.

**SINGLE-END 2-FLUTE EXOMILLS**



STOCK NO.	MILL DIA.	LENGTH OF CUT	OVERALL LENGTH
OSG62003	1/4	1/2	2-5/16
OSG62005	3/8	9/16	2-5/16
OSG62011	1/2	1"	3"
OSG62021	5/8	1-5/16	3-7/16
OSG62031	3/4	1-5/16	3-9/16
OSG62051	1"	1-5/8	4-1/8

**SINGLE-END 4-FLUTE EXOMILLS**



STOCK NO.	MILL DIA.	LENGTH OF CUT	OVERALL LENGTH
OSG64105	3/8	3/4	2-1/2
OSG64111	1/2	1-1/4	3-1/4
OSG64121	5/8	1-5/8	3-3/4
OSG64131	3/4	1-5/8	3-7/8
OSG64151	1"	2"	4-1/2

**SINGLE-END - 4-FLUTE  
LONG LENGTH EXOMILLS**



STOCK NO.	MILL DIA.	LENGTH OF CUT	OVERALL LENGTH
OSG64603	1/4	1/2	2-5/16
OSG64605	3/8	9/16	2-5/16
OSG64611	1/2	1"	3"
OSG64621	5/8	1-5/16	3-7/16
OSG64631	3/4	1-5/16	3-9/16
OSG64651	1"	1-5/8	4-1/8

**EXOCARB END MILLS**

HIGH PERFORMANCE MULTI-LAYER TIAIN COATED SUB-MICROGRAIN CARBIDE END MILLS.

**MINIATURE METRIC BALL END MILLS**



STOCK NO.	MILL DIA.	LENGTH OF CUT	OVERALL LENGTH
OSG8523508	0.4 x 0.8MM	2MM	40MM
OSG8523510	0.5 x 1MM	2.5MM	40MM

**STUB LENGTH  
METRIC BALL END MILLS**



STOCK NO.	MILL DIA.	LENGTH OF CUT	OVERALL LENGTH
OSG8518006	3 x 6MM	6MM	90MM

**METRIC BALL END MILLS**

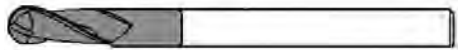

STOCK NO.	MILL DIA.	LENGTH OF CUT	OVERALL LENGTH
OSG8521020	1 x 2MM	5MM	50MM
OSG8521030	1.5 x 3MM	8MM	60MM
OSG8521040	2 x 4MM	8MM	70MM
OSG8521041	2 x 4MM	8MM	60MM
OSG8521050	2.5 x 5MM	10MM	80MM
OSG8521060	3 x 6MM	12MM	90MM
OSG8521070	3.5 x 7MM	14MM	90MM
OSG8521080	4 x 8MM	14MM	100MM
OSG8521100	5 x 10MM	18MM	100MM
OSG8521120	6 x 12MM	22MM	110MM

**LONG SHANK  
METRIC BALL END MILLS**

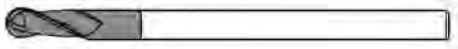

STOCK NO.	MILL DIA.	LENGTH OF CUT	OVERALL LENGTH
OSG8541120	6 x 12MM	22MM	200MM

WHAT AN AUTOMATED SOCIETY WE LIVE IN. HAVE YOU EVER NOTICED THAT WHEN A TRAFFIC SIGNAL TURNS GREEN, IT AUTOMATICALLY ACTIVATES THE HORN OF THE CAR BEHIND YOU?

### HI QUALITY, LOW COST END MILLS

#### SINGLE-END 2 FLUTE END MILLS



STOCK NO.	MILL DIA.	LENGTH OF CUT	OVERALL LENGTH
IZ02016	1/4	1/2	2-5/16
IZ02028	5/16	9/16	2-5/16
IZ02040	3/8	9/16	2-5/16
IZ02068	5/8	1-5/16	3-7/16
IZ02080	3/4	1-5/16	3-9/16
IZ02100	1"	1-1/2	3-3/4
IZ02104	1"	1-5/8	4-1/8

#### SINGLE-END 4 FLUTE END MILLS



STOCK NO.	MILL DIA.	LENGTH OF CUT	OVERALL LENGTH
IZ02212	1/4	5/8	2-7/16
IZ02228	5/16	3/4	2-1/2
IZ02244	3/8	3/4	2-1/2
IZ02268	1/2	1-1/4	3-1/4
IZ02288	5/8	1-5/8	3-3/4
IZ02308	3/4	1-5/8	3-7/8

#### DOUBLE-END 4 FLUTE END MILLS



STOCK NO.	MILL DIA.	LENGTH OF CUT	OVERALL LENGTH
IZ02400	1/8	3/8	3-1/16
IZ02424	1/4	5/8	3-3/8
IZ02440	3/8	3/4	3-1/2
IZ02452	1/2	1"	4-1/8

#### ROUGHING END MILLS



STOCK NO.	MILL DIA.	LENGTH OF CUT	OVERALL LENGTH
IZ02508	1/4	5/8	2-7/16
IZ02516	1/4	1-3/8	3-1/8
IZ02524	5/16	3/4	2-1/2
IZ02532	5/16	1-3/8	3-1/8
IZ02572	7/16	1	2-11/16
IZ02628	5/8	2-1/2	4-5/8
IZ02668	3/4	3"	5-1/4

#### LONG ROUGHING END MILLS



STOCK NO.	MILL DIA.	LENGTH OF CUT	OVERALL LENGTH
IZ02596	1/2	2"	4"
IZ02732	1"	4"	6-1/2"



CAN'T  
FIND  
IT



CALL!

**CALL US FOR ALL YOUR NEEDS**  
**855-785-TOOL**

SATAN AGREED TO BE INTERVIEWED ON THE LARRY KING SHOW. ASKED WHAT HE THOUGHT WERE HIS GREATEST ACCOMPLISHMENTS, THE DEVIL THOUGH FOR A MINUTE.

"I ALWAYS LOOK BACK WITH A SMILE ON THE SINKING OF THE *TITANIC*," HE MUSED. "BUT THERE ARE SO MANY FOND MEMORIES OF WARS, DISASTERS, AND CITIES LAID WASTE, IT'S HARD TO PICK OUT A FAVORITE."

"COME ON," PRESSED KING. "THERE MUST BE ONE FOUL DEED YOU CONSIDER YOUR CROWNING ACHIEVEMENT."

"WELL, YES," ADMITTED SATAN. "I INVENTED CALL WAITING."





**SOLID CARBIDE END MILLS**

**SOLID CARBIDE END MILLS  
 SINGLE-END - 2-FLUTE**



STOCK NO.	MILL DIA.	LENGTH OF CUT	OVERALL LENGTH
SGS02	1/16	3/16	1-1/2
SGS03	3/32	5/16	1-1/2
SGS04	1/8	1/2	1-1/2
SGS06	3/16	5/8	2"
SGS08	1/4	3/4	2-1/2
SGS09	5/16	13/16	2-1/2
SGS10	3/8	1"	2-1/2
SGS102	1/2	1"	3"
SGS103	5/8	1-1/4	3-1/2
SGS104	3/4	1-1/2	4"
SGS105	7/8	1-1/2	4"
SGS106	1"	1-1/2	4"

**SINGLE-END - 4FLUTE**



STOCK NO.	MILL DIA.	LENGTH OF CUT	OVERALL LENGTH
SGS21	1/16	3/16	1-1/2
SGS215	3/32	5/16	1-1/2
SGS22	1/8	1/2	1-1/2
SGS1819	1/8	1"	3"
SGS225	5/32	9/16	2"
SGS23	3/16	5/8	2"
SGS1820	3/16	1-1/8	3"
SGS24	1/4	3/4	2-1/2
SGS1821	1/4	1-1/2	4"
SGS25	5/16	13/16	2-1/2
SGS26	3/8	1"	2-1/2
SGS18226	3/8	1-1/8	3"
SGS18227	3/8	1-3/4	4"
SGS1823	3/8	2-1/2	6"
SGS28	1/2	1"	3"
SGS18251	1/2	2"	4"
SGS1825	1/2	3"	6"
SGS30	5/8	1-1/4	3-1/2
SGS1831	5/8	2-1/4	5"
SGS31	3/4	1-1/2	4"
SGS1832	3/4	2-1/4	5"
SGS1833	3/4	3"	6"
SGS311	1"	1-1/2	4"

**SOLID CARBIDE END MILLS  
 DOUBLE-END - 2-FLUTE**

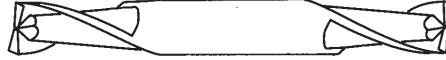

STOCK NO.	MILL DIA.	LENGTH OF CUT	OVERALL LENGTH
SGS31118	3/16	1/2	3-1/4
SGS31106	1/4	1/2	2-1/2
SGS32	1/4	5/8	3"
SGS31108	3/8	1/2	2-1/2
SGS34	3/8	3/4	3-1/2
SGS31110	1/2	5/8	3"
SGS36	1/2	1"	4"

**DOUBLE-END - 4-FLUTE**



STOCK NO.	MILL DIA.	LENGTH OF CUT	OVERALL LENGTH
SGS13	3/16	1/2	3-1/4
SGS1076	1/4	1/2	2-1/2
SGS14	1/4	5/8	3"
SGS15	5/16	3/4	3-1/2
SGS1078	3/8	1/2	2-1/2
SGS16	3/8	3/4	3-1/2
SGS1080	1/2	5/8	3"
SGS18	1/2	1"	4"

**SOLID CARBIDE END MILLS  
 BALL STYLE - SINGLE-END - 2-FLUTE**



STOCK NO.	MILL DIA.	LENGTH OF CUT	OVERALL LENGTH
SGS3802	1/16	1/4	1-1/2
SGS3804	1/8	1/2	1-1/2
SGS3806	3/16	5/8	2"
SGS3808	1/4	3/4	2-1/2
SGS3810	3/8	1"	2-1/2
SGS3812	1/2	1"	3"

**BALL STYLE - SINGLE-END - 4-FLUTE**



STOCK NO.	MILL DIA.	LENGTH OF CUT	OVERALL LENGTH
SGS42	1/8	1/2	1-1/2
SGS424	1/8	1"	3"
SGS425	5/32	9/16	2"
SGS43	3/16	5/8	2"
SGS434	3/16	1-1/8	3"
SGS44	1/4	3/4	2-1/2
SGS444	1/4	1-1/2	4"
SGS45	5/16	13/16	2-1/2
SGS46	3/8	1"	2-1/2
SGS464	3/8	1-3/4	4"
SGS48	1/2	1"	3"
SGS4802	1/2	2"	4"

**BALL STYLE - DOUBLE END - 4 FLUTE**



STOCK NO.	MILL DIA.	LENGTH OF CUT	OVERALL LENGTH
SGS441	1/4	1/2	2-1/2
SGS461	3/8	1/2	2-1/2

NOT SURE  
 ABOUT  
 SOMETHING?  
 GIVE US  
 A CALL!  
 ONE OF OUR  
 ASSOCIATES  
 WILL BE  
 MORE THAN  
 HAPPY  
 TO HELP  
 YOU  
 OUT.

PRICES  
 AND  
 COMPLETE  
 INFORMATION  
 AVAILABLE  
 UPON  
 REQUEST.

WHAT IS THE DIFFERENCE BETWEEN A  
 TAXIDERMIST AND A TAX COLLECTOR?  
 THE TAXIDERMIST TAKES ONLY YOUR  
 SKIN.

--MARK TWAIN

**CORNER ROUNDING END MILLS, R8 COLLETS, INDEXABLE CENTER DRILL**

**CORNER ROUNDING END MILLS**



**HSS - 4-FLUTE**

STOCK NO.	MILL DIA.	LENGTH OF CUT	OVERALL LENGTH
STC1310061	3/32	1/2	2-1/2
STC1310082	1/8	5/8	3"
STC1310122	3/16	7/8	3"
STC1310162	1/4	1"	3"
STC1310202	5/16	1-1/8	3-1/4
STC1310242	3/8	1-1/4	3-1/2

**R8 COLLETS**



STOCK NO.	SIZE
STC1995108	1/8
STC1995112	3/16
STC1995116	1/4
STC1995120	5/16
STC1995124	3/8
STC1995132	1/2
STC1995140	5/8
STC1995148	3/4

ADDITIONAL ITEMS AND SIZES AVAILABLE UPON REQUEST

**CNC INDEXABLE CENTER DRILL**



FOR CHAMFERING, CENTER-DRILLING, COUNTERSINKING, AND V-GROOVING WITH ONE TOOL. SINGLE INSERT CHIP ENABLES TOOL TO ELIMINATE VIBRATION. 90° POINT ANGLE. 4-1/2" OAL.

STOCK NO. OSG738010

**CARBIDE INSERT CHIP FOR CENTERING DRILL TOOL**



FOR STEELS APPLICATIONS  
NK2020 POINT ANGLE

STOCK NO. OSG738120



THIS IS A COMPREHENSIVE CATALOG OF OUR MAJOR LINES AND SERVICES, BUT IT DOES NOT SHOW ALL AVAILABLE PRODUCT LINES. IF THERE IS SOMETHING YOU NEED THAT IS NOT SHOWN, WE EITHER CARRY IT OR CAN GET IT. PLEASE CALL US FOR INFORMATION.

**CALL US FOR ALL YOUR NEEDS  
855-785-TOOL**



**CARBIDE AND SQUARE TOOL BITS**

**CARBIDE TOOL BITS**

**TYPES**

**C-2 (SERIES 883) IS FOR MACHINING CAST IRON AND NON-FERROUS MATERIALS.**

**C-6 (SERIES 370) IS FOR BOTH GENERAL PURPOSE AND HEAVY-DUTY USE ON STEELS.**

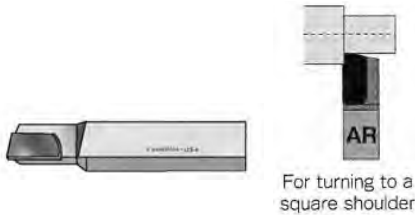

STOCK NO.	SIZE	TYPE
CHPAR4883	1/4	C-2
CHPAR4	1/4	C-6
CHPAR5883	5/16	C-2
CHPAR5	5/16	C-6
CHPAR6883	3/8	C-2
CHPAR6	3/8	C-6
CHPAR7	7/16	C-6
CHPAR8883	1/2	C-2
CHPAR8	1/2	C-6
CHPAR10883	5/8	C-2



STOCK NO.	SIZE	TYPE
CHPAL4883	1/4	C-2
CHPAL4	1/4	C-6
CHPAL5883	5/16	C-2
CHPAL5	5/16	C-6
CHPAL6883	3/8	C-2
CHPAL6	3/8	C-6
CHPAL7	7/16	C-6
CHPAL8883	1/2	C-2
CHPAL8	1/2	C-6
CHPAL10883	5/8	C-2
CHPAL12883	3/4	C-2
CHPAL12	3/4	C-6

A GENTLEMAN ENTERED A BUSY FLORIST SHOP THAT DISPLAYED A LARGE SIGN THAT READ "SAY IT WITH FLOWERS."  
"WRAP UP ONE ROSE," HE TOLD THE FLORIST.  
"ONLY ONE?" THE FLORIST ASKED.  
"JUST ONE," THE CUSTOMER REPLIED. "I'M A MAN OF FEW WORDS."



STOCK NO.	SIZE	TYPE
CHPC8	1/2	C-6

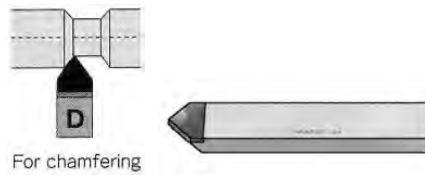

STOCK NO.	SIZE	TYPE
CHPD4	1/4	C-6
CHPD5	5/16	C-6
CHPD6	3/8	C-6
CHPD8	1/2	C-6



STOCK NO.	SIZE	TYPE
CHPE5883	5/16	C-2
CHPE5	5/16	C-6
CHPE6	3/8	C-6
CHPE8883	1/2	C-2
CHPE8	1/2	C-6

WALKING DOWN THE STREET, A DOG SAW A SIGN IN AN OFFICE WINDOW. "HELP WANTED. MUST TYPE 70 WORDS A MINUTE. MUST BE COMPUTER LITERATE. MUST BE BILINGUAL. AN EQUAL-OPPORTUNITY EMPLOYER."

THE DOG APPLIED FOR THE POSITION, BUT HE WAS QUICKLY REBUFFED. "I CAN'T HIRE A DOG FOR THIS JOB," THE OFFICE MANAGER SAID. BUT WHEN THE DOG POINTED TO THE LINE THAT READ "AN EQUAL-OPPORTUNITY EMPLOYER," THE OFFICE MANAGER SIGHED AND ASKED, "CAN YOU TYPE?" SILENTLY, THE DOG WALKED OVER TO A TYPEWRITER AND FLAWLESSLY BANGED OUT A LETTER. "CAN YOU OPERATE A COMPUTER?" THE MANAGER INQUIRED. THE DOG THEN SAT DOWN AT A TERMINAL, WROTE A PROGRAM AND RAN IT PERFECTLY.

"LOOK, I STILL CAN'T HIRE A DOG FOR THIS POSITION," SAID THE EXASPERATED OFFICE MANAGER. "YOU HAVE FINE SKILLS, BUT I NEED SOMEONE WHO'S BILINGUAL. IT SAYS SO RIGHT IN THE AD."

THE DOG LOOKED UP AT THE MANAGER AND SAID, "MEOW."

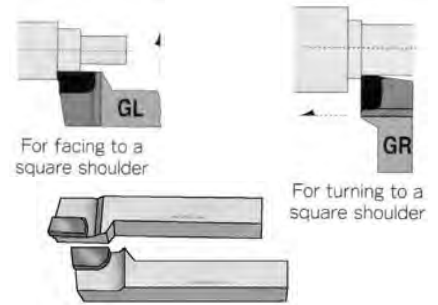

STOCK NO.	SIZE	TYPE
CHPGL12883	3/4	C-2
CHPGR12883	3/4	C-2

**SQUARE TOOL BITS**



**POLISHED AND GROUND FINISH. HIGH SPEED STEEL. 5% COBALT. WEAR RESISTANT.**

STOCK NO.	SIZE (SQUARE)	OVERALL LENGTH
DTFC61004	1/4	2-1/2
DTFC61005	5/16	2-1/2
DTFC61006	3/8	3"
DTFC61008	1/2	4"

**ADDITIONAL ITEMS AND SIZES AVAILABLE UPON REQUEST**

**IT'S OUR PLEASURE TO ASSIST YOU**  
**QUALITY PRODUCTS AND SERVICE**

## CARBIDE AND CERAMIC INDEXABLE INSERTS

### CARBIDE INSERTS

#### GRADES

**C5** IS FOR BOTH GENERAL PURPOSE AND HEAVY-DUTY USE ON STEELS.

**C5TI** IS FOR APPLICATIONS NEEDING A TITANIUM NITRIDE COATING. THIS IS DESIGNED FOR MILLING STEEL AT HIGHER SPEEDS WITH BETTER WEAR-RESISTANCE AND FOR LONGER TOOL LIFE.



STOCK NO. GRADE  
**DFFF50CNMG432TI** C5/C6TI



STOCK NO. GRADE  
**DFFF50TNMG322** C5/C6  
**DFFF50TNMG322TI** C5/C6TI  
**DFFF50TNMG432** C5/C6  
**DFFF50TNMG432R** C5/C6  
**DFFF50TNMG432TI** C5/C6TI  
**DFFF50TNMG433** C5/C6  
**DFFF50TNMG433TI** C5/C6TI  
**DFFF50TNMG434** C5/C6



STOCK NO. GRADE  
**DFFF50TNMP432** C5/C6



STOCK NO. GRADE  
**DFFF50TPG221** C5/C6  
**DFFF50TPG321** C5/C6  
**DFFF50TPG322** C5/C6  
**DFFF50TPG322TI** C5/C6TI  
**DFFF50TPG432** C5/C6  
**DFFF50TPG433TI** C5/C6TI

THE PESSIMIST COMPLAINS ABOUT THE WIND;  
 THE OPTIMIST EXPECTS IT TO CHANGE; THE  
 REALIST ADJUSTS THE SAILS.  
 --LENOARD LOUIS LEVINSON

THERE ARE LITERALLY THOUSANDS OF INDEXABLE INSERTS AVAILABLE. THE ITEMS WE STOCK ARE THE POPULAR STYLES AND SIZES THAT REFLECT OUR CUSTOMER'S NEEDS. CALL US TO INQUIRE ABOUT ANY ADDITIONAL INSERTS THAT MAY SUIT YOUR APPLICATION.



STOCK NO. GRADE  
**DFFF50SPG632** C5/C6



STOCK NO. GRADE  
**CER12** C5/C6TI



STOCK NO. GRADE  
**DFFF70SNW64** C5/C6



STOCK NO. GRADE  
**DFFF48TT221TI** C5/C6  
**DFFF4840240** C5/C6



STOCK NO. GRADE  
**CER04** C5/C6TI



STOCK NO. GRADE  
**CER01** C5/C6TI  
**CER02** C5/C6TI



STOCK NO. GRADE  
**CER03** C5/C6TI

### CERAMIC INSERTS A2 GRADE



STOCK NO.  
**DFFF55CNGA432**  
**DFFF55CNGA433**  
**DFFF55CNGA543**



STOCK NO.  
**DFFF55DNGA433**



STOCK NO.  
**DFFF55RNGA43**



STOCK NO.  
**DFFF55TNGA433**



STOCK NO.  
**DFFF55VNGA333**  
**DFFF55VNGA432**

**NEW ITEMS ARE ADDED DAILY  
 TO KEEP OUR STOCK UP TO  
 DATE. CALL WITH YOUR  
 INQUIRIES WHEN YOU WANT  
 AN ITEM THAT IS NOT LISTED.**

BAND SAW BLADE BRIEFING

BLADE BASICS

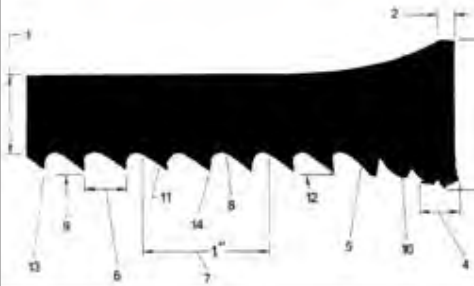

1. **Blade Back**—The body of the blade not including tooth portion.
2. **Thickness**—The thickness of the blade.
3. **Width**—The nominal dimension of a saw blade is measured from the tip of the tooth to the back of the band.
4. **Set**—The bending of teeth to right or left to allow clearance of the back through the cut.
5. **Tooth**—The cutting portion of a saw blade.
6. **Tooth Pitch**—The distance from the tip of one tooth to the tip of the next tooth.
7. **T.P.I.**—The number of teeth per inch.
8. **Gullet**—The curved area at the base of the tooth.
9. **Gullet Depth**—The distance from the tooth tip to the bottom of the gullet.
10. **Tooth Face**—The surface of the tooth on which the chip is formed.
11. **Tooth Back**—The surface of the tooth opposite the tooth face.
12. **Tooth Back Clearance Angle**—The angle of the tooth back measured in relation to the cutting direction of the saw.
13. **Tooth Rake Angle**—The angle of the tooth face measured with respect to a line perpendicular to the cutting direction of the saw.
14. **Tooth Tip**—The cutting edge of the saw tooth.

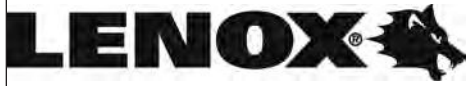

Blade Construction

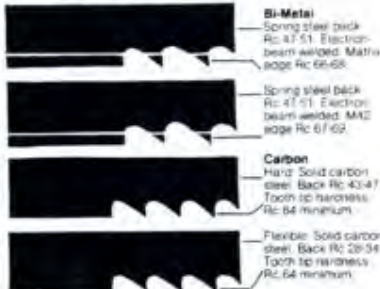

**Bi-Metal:** Modified cobalt high-speed steel edge electron-beam welded to tough spring steel back. For production, semi-production, general cutting and tool and die work on horizontal and vertical automatic and manual machines.

**Lenox Examples:**  
Edge: Matrix  
•Matrix Electron Weld®  
Edge: M42  
•Billet Master  
•Diamond 2\* •Mercuryl

**Carbon:** For lighter, non-production cutting on manual machines where the higher performance of bi-metal blades is not required.

**Lenox Examples:**  
Edge: Hardened Carbon Steel  
•Neo-Type®  
•Flex Back  
•Friction Band  
•Wood/Core Band

Set

Refers to positioning of tooth tip to right or left to provide clearance for the blade. Lenox precision-set tolerance is ±.002".



\***Lenox Raker** 5 Sequence: right, left, right, left, raker (straight) 2 Sequence for 4 pitch: right, left, right, left, raker (straight)



\***Raker** 3 Sequence: right, left, raker



**Vari-Raker** Right, left, right, left, etc. raker, with sequence depending on tooth pitch. Used with Variable and Variable Positive tooth forms.



**Alternate** Right, left throughout. No raker.



**Wavy** The alternating of series of teeth right, one raker, and series of teeth left. These right and left teeth are positioned in varying sets.

\*Lenox Raker set is used for the following tooth pitches: 3, 4, 6, 8, 10, 12 & 14  
Raker set is used for the following tooth pitches: 1, 1 1/2, 2, 1 1/8 & 3/4

TOOTH PITCH

Fewer than 24 teeth in the zone may cause tooth stoppage, more than 24 teeth will usually lead to tooth stripage or gullet clogging. Best results are obtained with 8 to 12.

TOOTH FORM

STANDARD



- Deep Gullets • Evenly Spaced Teeth
- 0 Degree Rake Angle

BENEFITS

- General Purpose Design For Wide Range of Applications

SKIP



- Wide Gullets • Evenly Spaced Teeth
- 0 Degree Rake Angle

BENEFITS

- Allows Good Chip Carrying Capacity in Non-Metallic Applications (Wood, Plastic, Cork, and Compositon Material)

HOOK



- Wide Gullets • Evenly Spaced Teeth
- 10 Degree Positive Rake Angle

BENEFITS

- Allows Good Chip Carrying Capacity in Non-Metallic Applications
- Good Cutting Performance on Cast Iron

VARIABLE POSITIVE



- Standard Tooth Forms
- Variable Tooth Spacing

BENEFITS

- Faster Cutting Rates
- Longest Blade Life

- Formed Positive Rake Angle
- Varying Gullet Depth

- Cuts Smoother
- Reduces Noise

- 0 Degree Rake Angle
- Varying Gullet Depth

BENEFITS

- Cuts Smoother
- Reduces Noise



- Standard Tooth Forms
- Variable Tooth Spacing

- Cuts More Efficiently
- Longer Blade Life





**BAND SAW BLADES**



**CARBON NEO-TYPE**



**1/8" BLADE WIDTH - .025 THICKNESS**

STOCK NO.	LENGTH	TOOTH	TOOTH FORM
LEN90003	7'-9"	14	R
LENB66	11'-11"	18	R

**3/16" BLADE WIDTH - .025 THICKNESS**

STOCK NO.	LENGTH	TOOTH	TOOTH FORM
LEN90037	7'-9-1/2"	14	R

**1/4" BLADE WIDTH - .025 THICKNESS**

STOCK NO.	LENGTH	TOOTH	TOOTH FORM
LENB183	4'-8-1/8"	6	S
LENB103	4'-9"	6	R
LENB104	4'-9"	18	R
LENB182	5'-8"	6	S
LENB93	5'-11"	10	R
LENB62	6'-6"	6	S
LEN90078	6'-8"	6	H
LENB29	6'-8"	6	S
LEN90082	6'-8"	14	R
LEN90083	6'-8"	18	R
LEN90092	7'-8"	10	R
LEN90095	7'-9"	6	H
LEN90096	7'-9"	6	S
LEN90097	7'-9"	10	R
LEN90098	7'-9"	14	R
LEN90115	7'-9"	18	R
LEN90105	7'-9-1/2"	10	R
LEN90106	7'-9-1/2"	14	R
LEN90107	7'-9-1/2"	18	R
LEN90121	7'-11-1/2"	14	R
LEN90126	8'	14	R
LEN91454	8'	18	R
LENB196	8'-7-1/2"	6	R
LEN90131	8'-9"	4	S
LENB39	9'-4"	14	R
LEN92417	9'-4"	18	R
LENB261	9'-9-1/2"	14	R
LENB011	10'	6	S
LEN90150	10'	10	R
LEN90151	10'	14	R
LENB12	10'	18	R
LENB03	10'-6"	6	S
LENB04	10'-6"	14	R
LENB164	10'-7-1/2"	4	S
LENB118	12'	4	S
LEN90166	12'	14	R
LENB045	14'-10"	14	R
LENB119	14'-11"	10	R
LENB60	15'	6	R
LENB61	15'	10	R

ALL BAND SAW BLADES ARE WELDED IN-HOUSE.  
ANY CONFIGURATION OF BLADE CAN BE CUSTOM-CRAFTED TO SUIT YOUR APPLICATION.  
CALL US WITH ALL YOUR NEEDS!

**TOOTH FORM ABBREVIATIONS**

RAKER- (R) VARIABLE- (V) HOOK- (H)  
SKIP- (S) WAVY- (W)

**3/8" BLADE WIDTH - .025 THICKNESS**

STOCK NO.	LENGTH	TOOTH	TOOTH FORM
LENB115	4'-8-1/8"	24	R
LENB165	4'-9"	6	R
LENB197	4'-11-1/4"	4	H
LENB133	5'	6	R
LENB147	5'-10"	4	H
LENB148	5'-10"	6	H
LEN90317	5'-11"	10	R
LEN90226	6'-8"	4	H
LEN90228	6'-8"	6	H
LEN90231	6'-8"	14	R
LENB135	6'-9-1/2"	4	H
LENB154	7'-8"	18	R
LENB50	7'-9"	4	H
LEN90239	7'-9"	6	H
LEN90240	7'-9"	10	R
LEN90241	7'-9"	14	R
LEN90242	7'-9"	18	R
LEN91488	7'-9"	24	R
LEN90244	7'-9-1/2"	4	S
LEN90245	7'-9-1/2"	6	H
LEN90248	7'-9-1/2"	18	R
LENB126	7'-10"	6	R
LENB1265	7'-10"	24	R
LENB198	8'	4	H
LEN90259	8'	18	R
LENB64	8'-1/2"	24	R
LENB205	9'-4"	14	R
LENB71	9'-6"	10	R
LENB712	9'-6"	18	R
LENB713	9'-6"	24	R
LENB146	10'	4	H
LEN90030	10'	14	R
LENB998	10'-6"	14	R
LENB256	12'-2"	4	H
LEN90306	12'-6"	4	H
LEN90308	12'-6"	6	H
LEN90311	12'-6"	14	R
LENB123	13'-2"	14	R
LENB117	14'-6"	14	R
LENB07	14'-8"	14	R
LENB132	15'	6	H
LEN89081	18'	4	H

**THE BLADES REPRESENTED ON THIS PAGE ARE ONLY A FRACTION OF THE ENDLESS BLADE CONFIGURATIONS AVAILABLE. CONTACT US WITH ALL YOUR BAND SAW BLADE NEEDS. IF WE DO NOT STOCK IT, WE WILL CUSTOM WELD IT FOR YOU.**

**1/2" BLADE WIDTH - .025 THICKNESS**

STOCK NO.	LENGTH	TOOTH	TOOTH FORM
LEN90401	5'	10	R
LEN90403	5'	14	R
LEN90405	5'	18	R
LEN90407	5'	24	R
LEN90419	5'-4-1/2"	6	R
LEN90421	5'-4-1/2"	10	R
LEN90423	5'-4-1/2"	14	R
LEN90425	5'-4-1/2"	18	R
LEN90427	5'-4-1/2"	24	R
LENB153	5'-6"	4	H
LEN90444	5'-6"	14	R
LEN90391	5'-8"	10	R
LEN90392	5'-8"	14	R
LEN90395	5'-8"	18	R
LENB17	5'-8"	24	R
LEN90464	6'-9"	14	R
LENB111	7'-1"	3	S
LEN90475	7'-5"	10	R
LEN90477	7'-5"	14	R
LEN90479	7'-5"	18	R
LEN90487	7'-6"	10	R
LEN90489	7'-6"	14	R
LENB22	7'-9"	3	S
LEN90761	7'-9"	4	S
LEN90500	7'-9"	6	H
LEN90503	7'-9"	10	R
LEN90505	7'-9"	14	R
LEN90507	7'-9"	18	R
LEN90509	7'-9"	24	R
LEN90514	7'-9-1/2"	4	S
LEN90515	7'-9-1/2"	6	H
LEN90518	7'-9-1/2"	10	R
LEN90520	7'-9-1/2"	14	R
LEN90528	7'-10"	10	R
LEN90530	7'-10"	14	R
LEN90545	7'-11-1/2"	14	R
LENB999	9'-3"	6	H
LEN91632	9'-4"	4	S
LEN91601	9'-4"	14	R
LEN90596	9'-5-1/2"	14	R
LENB128	9'-6"	18	R
LENB124	9'-6"	24	R
LENB263	9'-9-1/2"	10	R
LENB262	9'-9-1/2"	14	R
LENB46	9'-9-3/4"	3	S
LEN90612	10'	14	R
LEN90613	10'	18	R
LENB89	11'-4"	6	R
LENB96	11'-4"	10	R
LEN90644	11'-6"	14	R
LEN90666	12'	4	S
LEN90670	12'	14	R
LEN90692	12'-6"	14	R
LEN90698	12'-7"	6	H
LEN90717	13'-6"	14	R
LENB19	13'-8"	8	R
LENB20	13'-8"	10	R
LENB21	13'-8"	18	R
LENB190	14'-9"	10	R
LEN91654	15'	10	R
LENB92	15'	18	R
LENB187	15'-7"	3	S
LENB186	15'-7"	4	S
LEN94532	18'	4	S
LENB42	18'	6	R
LENB69	18'-9"	3	S
LENB139	22'-3"	10	R



**BAND SAW BLADES**



**CARBON NEO-TYPE**



**5/8" BLADE WIDTH - .032 THICKNESS**

STOCK NO.	LENGTH	TOOTH	TOOTH FORM
LEN90817	7'-9"	10	R
LEN90819	7'-9"	14	R
LEN90847	8'-2-1/2"	10	R
LEN90858	8'-5"	10	R
LEN90860	8'-5"	14	R
LEN90872	8'-10"	10	R
LENB49	12'-7"	14	R

**3/4" BLADE WIDTH - .032 THICKNESS**

STOCK NO.	LENGTH	TOOTH	TOOTH FORM
LENB189	7'-3-1/2"	10	R
LENB68	7'-8"	10	R
LEN90913	7'-9"	4	H
LEN90931	7'-9"	8	R
LEN90929	7'-9"	10	R
LEN90930	7'-9"	14	R
LEN90920	7'-9"	18	R
LEN91707	7'-9-1/2"	4	H
LENB77	7'-10-1/2"	10	R
LENB78	8'-5"	10	R
LEN90944	8'-5"	14	R
LEN90950	8'-10"	14	R
LEN90957	8'-11"	14	R
LEN90960	9'	6	R
LEN90962	9'	10	R
LEN90971	9'-2"	6	R
LEN90974	9'-2"	10	R
LEN90983	9'-6"	14	R
LEN90995	9'-7-1/2"	14	R
LEN90997	9'-7-1/2"	18	R
LEN91004	10'	3	H
LEN91003	10'	4	H
LEN91006	10'	10	R
LEN91020	10'-5"	6	R
LEN91023	10'-5"	10	R
LEN91027	10'-5"	14	R
LENB131	10'-7-1/2"	3	H
LEN91772	10'-9"	6	R
LEN91041	10'-9"	10	R
LENB172	10'-9-1/4"	6	R
LENB171	10'-9-1/4"	10	R
LENB34	10'-10-1/2"	4	H
LEN91052	10'-10-1/2"	6	R
LEN91055	10'-10-1/2"	10	R
LEN91059	10'-10-1/2"	14	R
LEN91091	11'-6"	10	R
LEN91095	11'-6"	14	R
LENB180	11'-8"	6	R
LENB193	11'-9"	4	H
LEN91111	11'-9"	10	R
LEN91120	12'-6"	3	H
LENB23	12'-6"	14	R
LENB250	13'-4"	10	R
LENB251	13'-4"	14	R
LENB26	13'-11"	14	R
LENB08	15'-8"	3	H
LENB09	15'-10"	14	R
LENB94	22'-3"	10	R

ALL BAND SAW BLADES ARE WELDED IN-HOUSE.  
 ANY CONFIGURATION OF BLADE CAN BE CUSTOM-CRAFTED TO SUIT YOUR APPLICATION.  
 CALL US WITH ALL YOUR NEEDS!

**TOOTH FORM ABBREVIATIONS**

RAKER- (R) VARIABLE- (V) HOOK- (H)  
 SKIP- (S) WAVY- (W)

**1" BLADE WIDTH - .035 THICKNESS**

STOCK NO.	LENGTH	TOOTH	TOOTH FORM
LENB194	9'-7-1/2"	14	R
LENB145	10'-8"	8	R
LENB80	10'-8-1/2"	14	R
LENB51	10'-9-1/2"	8	R
LENB511	10'-9-1/2"	10	R
LEN91228	10'-10-1/2"	6	R
LEN91229	10'-10-1/2"	8	R
LEN91230	10'-10-1/2"	10	R
LEN91938	11'	6	R
LEN91236	11'	10	R
LEN91238	11'	14	R
LEN91240	11'-5"	8	R
LEN91246	11'-6"	6	R
LEN91247	11'-6"	8	R
LEN91248	11'-6"	10	R
LEN91250	11'-6"	14	R
LENB18	11'-6-1/2"	8	R
LEN91873	11'-7"	14	R
LEN91258	12'	6	R
LEN91259	12'	8	R
LENB137	12'-7"	3	H
LEN91288	13'-6"	8	R
LEN91302	13'-11"	14	R
LENB138	14'-6"	3	H
LEN91965	16'	3	H
LENB33	18'-8"	3	H
LENB121	19'-6"	6	R
LENB16	20'	3	H
LENB107	21'	10	R
LENB13	21'-3"	3	H
LENB06	22'-9"	3	H

*THE BLADES REPRESENTED ON THIS PAGE ARE ONLY A FRACTION OF THE ENDLESS BLADE CONFIGURATIONS AVAILABLE. CONTACT US WITH ALL YOUR BAND SAW BLADE NEEDS. IF WE DO NOT STOCK IT, WE WILL CUSTOM WELD IT FOR YOU.*

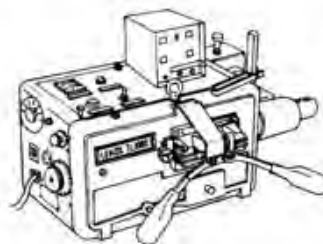

**BI-METAL**



**1/4" BLADE WIDTH - .025 THICKNESS**

STOCK NO.	LENGTH	TOOTH	TOOTH FORM
LENB01	9'	10	R
LENB120	10'	10/14	V
LENB70	12'	10/14	V

**3/8" BLADE WIDTH - .025 THICKNESS**

LENB41	10'-8"	10/14	V
LENB88	11'-9"	4	H

**1/2" BLADE WIDTH - .025 THICKNESS**

LENB37	5'-4-1/2"	8/12	V
LENB255	5'-4-1/2"	10/14	V
LENB25	5'-4-1/2"	14	R
LENB2316	5'-8"	14	R
LENB54	5'-8-1/2"	8/12	R
LENB114	6'-1"	14	R
LENB76	6'-9"	14	R
LENB1105	7'-1"	10/14	V
LENB110	7'-1"	14	R
LENB195	7'-5"	10/14	V
LENB113	7'-5"	14	R
LENB95	7'-8-1/2"	14	R
LENB57	7'-9"	8/12	V
LENB97	7'-9"	10/14	V
LENB199	7'-9-1/2"	10/14	V
LENB188	7'-9-1/2"	14	R
LENB73	8'	8/12	V
LENB122	8'	10/14	V
LENB178	8'-1/2"	14	R
LENB02	9'	10	R
LENB106	9'-7"	14	R
LENB151	10'	10/14	V
LENB112	10'-2"	10/14	V
LENB90	10'-2"	14	R
LENB1505	10'-5"	8/12	V
LENB136	10'-5"	10/14	V
LENB74	10'-5"	14	R
LENB191	11'-9"	14	R
LENB150	12'	8/12	V
LENB149	12'	10/14	V
LENB109	12'	14	R
LENB0349	12'-6"	10/14	V
LENB144	13'-8"	14	R
LENB59	15'	8/12	V
LENB206	15'-7"	4	H
LENB141	22'-3"	10	R

*SERVICE  
 YOU CAN DEPEND ON*

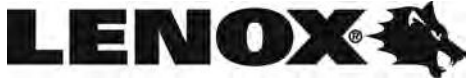

**BAND SAW BLADES**



ALL BAND SAW BLADES ARE WELDED IN-HOUSE.  
ANY CONFIGURATION OF BLADE CAN BE CUSTOM-CRAFTED TO SUIT YOUR APPLICATION.  
CALL US WITH ALL YOUR NEEDS!

**TOOTH FORM ABBREVIATIONS**

RAKER- (R) VARIABLE- (V) HOOK- (H)  
SKIP- (S) WAVY- (W)

**BI-METAL**



**3/4" BLADE WIDTH - .035 THICKNESS**

STOCK NO.	LENGTH	TOOTH	TOOTH FORM
LENB130	7'-6"	5/8	V
LEN80426	7'-9"	4/6	V
LENB116	7'-9"	5/8	V
LEN80427	7'-9"	6/10	V
LEN80429	7'-9"	8/12	V
LEN80430	7'-9"	10/14	V
LEN80431	7'-9"	14	R
LENB67	7'-9-1/2"	8/12	V
LENB200	7'-9-1/2"	10/14	V
LEN80444	8'-5"	4/6	V
LEN80446	8'-5"	6/10	V
LEN80448	8'-5"	8/12	V
LEN80450	8'-5"	14	R
LEN80458	8'-10"	10/14	V
LEN80468	8'-11"	14	R
LEN80470	9'	4/6	V
LEN80471	9'	6	R
LEN80476	9'	8/12	V
LEN80477	9'	10/14	V
LEN80478	9'	14	R
LEN80493	9'-6"	4/6	V
LEN81505	9'-6"	5/8	V
LEN80494	9'-6"	6/10	V
LEN80496	9'-6"	8/12	V
LEN80497	9'-6"	10/14	V
LEN80503	9'-7"	8/12	V
LEN80504	9'-7"	10/14	V
LEN80508	9'-7-1/2"	6/10	V
LEN80511	9'-7-1/2"	10/14	V
LEN80512	9'-7-1/2"	14	R
LEN82435	10'	4/6	V
LEN82436	10'	5/8	V
LEN80523	10'	6/10	V
LEN80524	10'	8/12	V
LEN80535	10'-5"	5/8	V
LEN80538	10'-5"	6/10	V
LEN80541	10'-5"	8/12	V
LEN80539	10'-5"	10	R
LEN80542	10'-5"	10/14	V
LEN80543	10'-5"	14	R
LEN80557	10'-10"	8/12	V
LEN80573	10'-10"	14	R
LEN80562	10'-10-1/2"	4/6	V
LEN80566	10'-10-1/2"	6/10	V
LENB27	10'-10-1/2"	8/12	V
LEN80570	10'-10-1/2"	10/14	V
LEN80576	10'-11"	4/6	V
LEN80608	11'-6"	4/6	V

(CONTINUED)

**3/4" BLADE WIDTH - .035 THICKNESS (CONTINUED)**

STOCK NO.	LENGTH	TOOTH	TOOTH FORM
LEN80611	11'-6"	5/8	V
LEN80613	11'-6"	6/10	V
LENB43	11'-6"	8/12	V
LEN80617	11'-6"	10/14	V
LEN80618	11'-6"	14	R
LEN81770	11'-8"	6/10	V
LEN80632	12'-1"	5/8	V
LEN80642	12'-6"	4/6	V
LEN80649	12'-6"	10/14	V
LENB143	13'-5"	8/12	V
LENB40	13'-6"	8/12	V
LEN80671	14'-6"	6/10	V
LEN80682	14'-8"	5/8	V
LEN80688	14'-8"	10/14	V
LENB48	14'-10"	4/6	V
LENB167	21'-2"	5/8	V
LENB166	21'-2"	8/12	V

*THE BLADES REPRESENTED ON THIS PAGE ARE ONLY A FRACTION OF THE ENDLESS BLADE CONFIGURATIONS AVAILABLE. CONTACT US WITH ALL YOUR BAND SAW BLADE NEEDS. IF WE DO NOT STOCK IT, WE WILL CUSTOM WELD IT FOR YOU.*

**1" BLADE WIDTH - .035 THICKNESS**

STOCK NO.	LENGTH	TOOTH	TOOTH FORM
LENB125	9'-2"	3/4	V
LENB1685	9'-7-1/2"	4/6	V
LENB169	9'-7-1/2"	10/14	V
LEN80754	10'-6"	6/10	V
LENB129	10'-8"	4/6	V
LENB108	10'-8-1/2"	6/10	V
LENB1081	10'-8"	8/12	V
LENB79	10'-9"	8/12	V
LENB177	10'-9-1/2"	6/10	V
LENB184	10'-10-1/4"	3/4	V
LEN80766	10'-10-1/2"	6/10	V
LENB98*	10'-11"	3/4	V
LEN80775	11'	4/6	V
LEN80777	11'	5/8	V
LEN80776	11'	6	R
LEN80779	11'	6/10	V
LEN80781	11'	8/12	V
LEN80782	11'	10/14	V

(CONTINUED)

**1" BLADE WIDTH - .035 THICKNESS (CONTINUED)**

STOCK NO.	LENGTH	TOOTH	TOOTH FORM
LENB91	11'-4"	5/8	V
LEN80789	11'-5"	3/4	V
LEN80794	11'-5"	5/8	V
LENB161	11'-5"	8/12	V
LEN80804	11'-6"	3/4	V
LEN80807	11'-6"	4/6	V
LEN84049	11'-6"	4/6	V
LEN80810	11'-6"	5/8	V
LEN80812	11'-6"	6/10	V
LEN80815	11'-6"	8/12	V
LEN80816	11'-6"	10/14	V
LEN80843	12'	3/4	V
LEN80846	12'	4/6	V
LENB35	12'	5/8	V
LENB134	12'	6	R
LEN80853	12'	6/10	V
LEN80856	12'	8/12	V
LEN80865	12'-1"	5/8	V
LEN80891	12'-4"	6/10	V
LEN80872	12'-4-1/2"	4/6	V
LEN80871	12'-4-1/2"	5/8	V
LENB163	12'-5"	5/8	V
LEN80852	12'-6"	3/4	V
LEN86249	12'-6"	3/4	V
LEN80901	12'-6"	4/6	V
LEN80905	12'-6"	6/10	V
LENB15	12'-7"	3/4	V
LEN80924	13'-3"	4/6	V
LEN809245	13'-3"	6	R
LEN80925	13'-3"	6/10	V
LEN80926	13'-3"	8/12	V
LEN80927	13'-4"	3/4	V
LEN86258	13'-4"	4/6	V
LEN86257	13'-6"	3/4	V
LEN80941	13'-6"	4/6	V
LEN80943	13'-6"	5/8	V
LEN87092	13'-6"	5/8	V
LEN80945	13'-6"	6/10	V
LEN80948	13'-6"	10/14	V
LEN80967	13'-11"	4/6	V
LEN80971	13'-11-1/4"	6/10	V
LEN81020	14'-6"	4/6	V
LEN81024	14'-6"	5/8	V
LEN81027	14'-6"	6/10	V
LEN81025	14'-6"	5/8	V
LEN81029	14'-6"	8/12	V
LENB1030	14'-6"	10/14	V
LENB162	21'	4/6	V
LENB168	21'	5/8	V
LENB179	21'-1"	5/8	V



"Mum! Come and see the coffee table I've made with my new tool-set!"



**BAND SAW BLADES, SAW STOCK, SAWING FLUID AND MICRONIZER APPLICATOR**

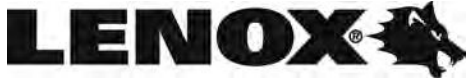

ALL BAND SAW BLADES ARE WELDED IN-HOUSE.  
ANY CONFIGURATION OF BLADE CAN BE CUSTOM-CRAFTED TO SUIT YOUR APPLICATION.  
CALL US WITH ALL YOUR NEEDS!

**TOOTH FORM ABBREVIATIONS**

RAKER- (R) VARIABLE- (V) HOOK- (H)  
SKIP- (S) WAVY- (W)

**BI-METAL**



**1-1/4" BLADE WIDTH - .042 THICK**

STOCK NO.	LENGTH	TOOTH	TOOTH FORM
LEN86314	13'-5"	3/4	V
LEN87716	13'-5"	5/8	V
LEN81205	14'-5"	4/6	V
LEN87192	14'-6"	5/8	V
LEN87205	15'	5/8	V

**PORTABLE BAND SAW BLADES**



**(PORTABANDS)**

BI-METAL CONSTRUCTION BLADES FOR USE WITH PORTABLE BAND SAWS. 44-7/8" LONG.

**LENOX BRAND**

STOCK NO.	DESCRIPTION
LEN80114	10/14 V
LEN80115	14 R
LEN80116	18 R
LEN80117	24 R
LEN80120*	14R

\*53-3/4 LONG

EVERYBODY WANTS TO GO BACK TO NATURE-- BUT NOT ON FOOT.

--WERNER MITSCH

**CARBON BAND SAW STOCK**

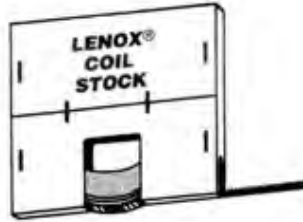

**NEO-TYPE - HARD TEMPERED BACK**

ONE PIECE CARBON STEEL CONSTRUCTION. RECOMMENDED FOR EVERY TYPE OF UTILITY CUTTING, INCLUDING CONTOUR WORK. CUTS BOTH METALS AND NON-METALS, SOLIDS, TUBING AND STRUCTURALS. MAXIMUM OPERATING SPEED OF 4,000 FPM. 100 FT. COILS IN STOCK. OTHER COIL LENGTHS AVAILABLE.

STOCK NO.	WIDTH	THICKNESS	RAKER (STD.)
LEN04022	1/4	.025	10
LEN04025	1/4	.025	18
LEN04029	3/8	.025	10
LEN04057	3/4	.032	6
LEN04058	3/4	.032	8



**CALL US FOR ALL YOUR NEEDS**  
**855-785-TOOL**



**ADDITIONAL ITEMS AND SIZES AVAILABLE UPON REQUEST**

**OVER 30,000 INVENTORY ITEMS IN STOCK!**



**CALL IN YOUR ORDER FOR PROMPT, COURTEOUS ASSISTANCE.**

# LENOX

## LENOX

# LENOX

### MASTER-GRIT HOLE SAWS



FEATURING TUNGSTEN CARBIDE GRIT EDGE. GULLETED CUTTING EDGE DESIGN. 3/16" THICK HEAVY-DUTY BACKING CAP AND 1-5/8" CUTTING DEPTH. GREATER HEAT AND WEAR RESISTANCE THAN BI-METAL. CUTS MATERIALS THAT BI-METAL HOLE SAWS WILL NOT: CERAMIC WALL TILE, GLASS, CAST IRON, FIBERGLASS, PLASTIC LAMINATES AND OTHER ABRASIVE MATERIALS. FAST CUTTING AND LONG LASTING.

STOCK NO.	SIZE
LEN29916	1"
LEN29918	1-1/8
LEN29920	1-1/4
LEN29924	1-1/2
LEN29932	2"
LEN29934	2-1/8
LEN29940	2-1/2
LEN29948	3"

A MAN WALKED INTO A SECOND-STORY BAR AND ORDERED A DRINK. THE MAN NEXT TO HIM BEGAN A CONVERSATION ABOUT WIND CURRENTS IN THE AREA. THE FIRST MAN SAID HE DIDN'T UNDERSTAND WHAT WAS SO SPECIAL ABOUT THE WIND, SO THE SECOND MAN SAID, "LET ME DEMONSTRATE."

WITH THAT, HE WENT TO THE WINDOW, JUMPED OUT, DID A LITTLE SPIN IN MIDAIR AND CAME BACK IN. "SEE HOW GREAT THE CURRENTS ARE? YOU CAN DO THE SAME THING."

AFTER A FEW MORE DRINKS AND MUCH PRODDING, THE FIRST MAN DECIDED TO TEST THE WIND CURRENTS. HE WENT TO THE WINDOW, JUMPED OUT AND FELL TO THE GROUND.

THE BARTENDER LOOKED AT THE OTHER MAN AND SAID, "SUPERMAN, YOU'RE REALLY MEAN WHEN YOU'RE DRUNK."

### HOLE SAWS

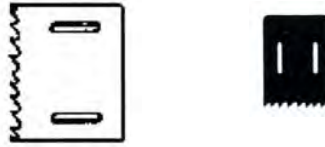

BI-METAL CONSTRUCTION. CUTS THROUGH STAINLESS STEEL AND OTHER METALS, PIPE, NAIL-EMBEDDED WOOD, HARDWOOD FLOORS, PLYWOOD AND PLASTICS. 1-1/2" CUTTING DEPTH. 4/6 VARI-TOOTH.

STOCK NO.	SIZE
LEN30009	9/16
LEN30010	5/8
LEN30011	11/16
LEN30012	3/4
LEN30013	13/16
LEN30014	7/8
LEN30015	15/16
LEN30016	1"
LEN30017	1-1/16
LEN30018	1-1/8
LEN30019	1-3/16
LEN30020	1-1/4
LEN30021	1-5/16
LEN30022	1-3/8
LEN30023	1-7/16
LEN30024	1-1/2
LEN30025	1-9/16
LEN30026	1-5/8
LEN30028	1-3/4
LEN30030	1-7/8
LEN30032	2"
LEN30033	2-1/16
LEN30034	2-1/8
LEN30036	2-1/4
LEN30038	2-3/8
LEN30040	2-1/2
LEN30041	2-9/16
LEN30042	2-5/8
LEN30044	2-3/4
LEN30046	2-7/8

STOCK NO.	SIZE
LEN30048	3"
LEN30050	3-1/8
LEN30052	3-1/4
LEN30054	3-3/8
LEN30056	3-1/2
LEN30058	3-5/8
LEN30060	3-3/4
LEN30064	4"
LEN30066	4-1/8
LEN30068	4-1/4
LEN30072	4-1/2
LEN30076	4-3/4
LEN30080	5"
LEN30088	5-1/2
LEN30096	6"

### CARBIDE-TIPPED HOLE SAWS



3 TEETH PER INCH. 1-1/2" CUTTING DEPTH. FOR CUTTING PLASTICS, FIBERGLASS, GRAPHITE, CAST IRON AND CERAMIC TILE, TITANIUM ALLOYS AND STAINLESS STEELS.

STOCK NO.	SIZE
LEN30212	3/4
LEN30214	7/8
LEN30216	1"
LEN30218	1-1/8
LEN30220	1-1/4
LEN30222	1-3/8
LEN30224	1-1/2
LEN30226	1-5/8
LEN30228	1-3/4
LEN30232	2"
LEN30234	2-1/8
LEN30236	2-1/4
LEN30240	2-1/2
LEN30248	3"

A PAIR OF HONEYMOONERS CHECKED INTO THE WATERGATE HOTEL IN WASHINGTON, D.C. THAT NIGHT, AS THE HUSBAND WAS ABOUT TO TURN OFF THE LIGHT, HIS BRIDE ASKED, "DO YOU THINK THIS ROOM IS BUGGED?"

"THAT WAS A LONG TIME AGO, SWEETHEART," HE REASSURED HER.

"BUT WHAT IF THERE'S A MICROPHONE SOMEWHERE? I'D BE SO EMBARRASSED."

SO THE GROOM SEARCHED UNDER TABLES AND BEHIND PICTURES. THEN HE TURNED BACK THE RUG. SURE ENOUGH, THERE WAS A FUNNY-LOOKING GIZMO IN THE FLOOR. HE TOOK OUT THE SCREWS, GOT RID OF THE HARDWARE, AND CLIMBED INTO BED.

THE NEXT MORNING THE NEWLYWEDS WERE AWAKENED BY A HOTEL CLERK WHO WANTED TO KNOW IF THEY HAD SLEPT WELL.

"WE DID," REPLIED THE GROOM. "WHY DO YOU ASK?"

"IT'S RATHER UNUSUAL," THE CLERK ANSWERED. "LAST NIGHT THE COUPLE IN THE ROOM BELOW YOURS HAD A CHANDELIER FALL ON THEM."



# FOR ALL YOUR INDUSTRIAL SUPPLIES

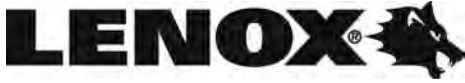

LENOX

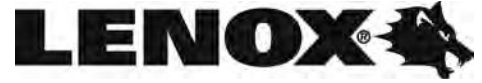

**ARBORS**



HOLE SAW SIZES 9/16 THROUGH 1-3/16 HAVE A 1/2-20 THREAD, AND USE 1L, 4L OR 5L ARBORS. HOLE SAW SIZES 1-1/4 THROUGH 6" HAVE A 5/8-18 THREAD, AND USE 2L OR 6L ARBORS.

STOCK NO.	SIZE	TYPE	SHANK
LEN30001	-1L 1/2	HEX	7/16
LEN30002	-2L 1/2	HEX	7/16
LEN30004	-4L 1/4	ROUND	1/4
LEN30005	-5L 3/8	HEX	3/8
LEN30006	-6L 3/8	HEX	3/8

**PILOT DRILLS**



STOCK NO.	CHUCK SIZE	FITS ARBORS
LEN30850	1/4	1L, 2L, 4L
LEN30851	1/4	5L, 6L

STOCK NO. **LEN30297** CARBIDE TIPPED PILOT DRILL

**ARBOR ADAPTER**



ADAPTS 1L, 4L & 5L ARBORS TO SAWS 1-1/4 THROUGH 6".

STOCK NO. **LEN30857**

**HOLE SAW EXTENSIONS**



STOCK NO. **LEN30846** (5-1/2")  
 STOCK NO. **LEN30847** (12")  
 STOCK NO. **LEN30848** (18")

ADDITIONAL PRODUCTS AVAILABLE  
 UPON REQUEST

**HOLE SAW KITS**

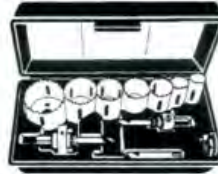

**AUTOMOTIVE**

FIVE SIZES USED TO INSTALL AIR CONDITIONER HOSES, DOOR LOCKS, SUN ROOFS, ETC. ONE EACH: 3/4, 7/8, 1", 1-1/8, 1-1/4. ONE 5L ARBOR AND ONE ARBOR ADAPTER ALSO INCLUDED.  
**STOCK NO. LEN30805**

**PLUMBER**

SIX SIZES MOST COMMONLY USED FOR PIPE TAP AND ENTRANCE. ONE EACH: 3/4, 7/8, 1-1/8, 1-1/2, 1-3/4, 2-1/4. ONE EACH ARBORS 2L & 4L. ONE SPARE PILOT DRILL AND ONE ARBOR ADAPTER ALSO INCLUDED.  
**STOCK NO. LEN30808**

**ELECTRICIAN**

SIX SIZES MOST FREQUENTLY USED FOR PIPE AND CONDUIT ENTRANCE. ONE EACH: 7/8, 1-1/8, 1-3/8, 1-3/4, 2", 2-1/2. ONE EACH ARBORS 1L & 2L. ONE SPARE PILOT DRILL INCLUDED.  
**STOCK NO. LEN30800**

**DELUXE**

TWELVE POPULAR SIZES. ONE EACH: 5/8, 3/4, 7/8, 1", 1-1/8, 1-1/4, 1-3/8, 1-1/2, 1-3/4, 2", 2-1/2, 3". ONE EACH ARBORS 1L & 2L. THREE SPARE PILOT DRILLS ALSO INCLUDED.  
**STOCK NO. LEN30820**

OTHER LENOX HOLE SAW KITS AVAILABLE  
 UPON REQUEST

WE ARE HERE TO HELP!



CALL US FOR ALL YOUR NEEDS  
**855-785-TOOL**

CALL WITH ANY  
 QUESTIONS  
 YOU MIGHT HAVE.



CALL US FOR ALL YOUR NEEDS  
**855-785-TOOL**



"And see this ring right here, Jimmy? ... That's another time when the old fellow miraculously survived some big forest fire."

# LENOX

## LENOX

# LENOX

### JIGSAW BLADES



BOSCH STYLE (B)      UNIVERSAL STYLE (U)



BAYONET STYLE (L)

BI-METAL CONSTRUCTION. CUTS THROUGH MOST MATERIALS, INCLUDING STAINLESS STEEL AND NAIL-EMBEDDED WOOD.

STOCK NO.	SIZE	STYLE	TEETH/ INCH
LEN20805	3-5/8 x 3/8 x .035	B	14 T
LEN20806	3-5/8 x 3/8 x .035	B	18 T
LEN20610	3" x 3/8 x .035	U	14 T
LEN20611	3" x 3/8 x .035	U	18 T
LEN20612	3" x 3/8 x .035	U	24 T
LEN20315	4-1/2 x 3/8 x .035	B	6 T
LEN20620	4-1/2 x 3/8 x .035	U	6 T
LEN20622	4-1/2 x 3/8 x .035	U	10 T

### 7 PIECE JIG SAW BLADE ASSORTMENT

STOCK NO. **LEN20606** (W/ VINYL POUCH)

### RECIPROCATING BLADES

BI-METAL CONSTRUCTION. CUTS THROUGH MOST MATERIALS, INCLUDING STAINLESS STEEL AND NAIL-EMBEDDED WOOD. 5 BLADES PER VINYL POUCH.

#### TYPES

- A) ROUGH WORK IN WOOD, FAST CUTTING, USED IN REMODELING/DEMOLITION WK.
- B) WOOD, ALL COMPOSITION MATERIAL.
- C) WOOD, COMPOSITIONS, PLASTIC, CAST ALUMINUM, NON-FERROUS METALS.
- D) WOOD, COMPOSITIONS, PLASTIC, CAST ALUMINUM, LIGHT NON-FERROUS METALS, STAINLESS STEEL.
- E) HEAVY-GAUGE METAL 1/4" - 1/2", HARD RUBBER, FIBER AND ANGLE IRON.
- F) HEAVY GAUGE METAL 1/8" - 1/4", CONDUIT AND TUBING, OPENING WOOD CRATES, REMOVING WOOD SIDING OR SHINGLES.
- G) CONTOURS- METALS UNDER 1/8"/3.2mm.
- H) METAL AND GALVANIZED PIPE 18 GAUGE & UNDER.
- I) PLASTER AND PLASTER BOARD.
- J) CARBIDE GRIT FOR CAST IRON AND CERAMICS.
- K) WOOD AND METAL. USED FOR FIRE AND RESCUE.



STOCK NO.	SIZE	TYPE	TEETH PER INCH
LEN20572	6" x 3/4 x .050	A	6 RAKER
LEN20582	9" x 3/4 x .050	A	6 RAKER
LEN20598	9" x 3/4 x .062	K	6 RAKER
LEN20597	9" x 7/8 x .050	K	10 RAKER
LEN20585	12" x 3/4 x .050	A	6 RAKER



STOCK NO.	SIZE	TYPE	TEETH PER INCH
LEN20521	3" x 1/4 x .025	G	18
LEN20550	4" x 3/4 x .035	E	14
LEN20552	4" x 3/4 x .035	F	18
LEN20554	4" x 3/4 x .035	H	24
LEN20560	6" x 3/4 x .035	B	6
LEN20562	6" x 3/4 x .035	C	10
LEN20564	6" x 3/4 x .035	E	14
LEN20566	6" x 3/4 x .035	F	18
LEN20568	6" x 3/4 x .035	H	24
LEN20570	6" x 3/4 x .035	I	6
LEN20592	6" x 3/4 x .050	K	10/14
LEN20580	8" x 3/4 x .035	D	10
LEN21519	8" x 3/4 x .035	D	14
LEN20578	8" x 3/4 x .035	F	18
LEN20576	8" x 3/4 x .035	J	GRIT EDGE
LEN20511	9" x 3/4 x .050	E	14

### 5 PIECE RECIPROCATING BLADE ASSORTMENT

STOCK NO. **LEN20502** (W/ VINYL POUCH)

### TRI-FOLD SAW

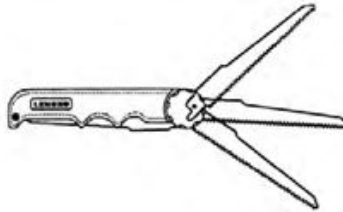

CUTS IN HARD-TO-GET-AT-PLACES. LIGHT-WEIGHT, DIE-CAST ALUMINUM HANDLE. RECIPROCATING BLADE FOLDS AWAY SAFELY. LOCKS IN THREE POSITIONS (SHOWN ABOVE). ACCEPTS ALL BRANDS OF RECIPROCATING BLADES USING 1/2" TANG. FITS IN POCKET. COMES WITH ONE BLADE FOR METAL CUTTING AND ONE BLADE FOR DRYWALL AND WOOD

STOCK NO. **LEN20997**

### HAND HACKSAW BLADES



HACKMASTER 2 BI-METAL HACKSAW BLADES CUT STAINLESS, PIPE, CONDUIT, BAR & ROD, ALUMINUM, BRASS, COPPER. VIRTUALLY UNBREAKABLE. SHOCK RESISTANT.

STOCK NO.	SIZE	TEETH PER INCH
LEN20141	10" x 1/2 x .025	24
LEN20116	12" x 1/2 x .025	18
LEN20117	12" x 1/2 x .025	24
LEN20118	12" x 1/2 x .025	32

### CROSSCUT SAW



STANLEY BRAND CROSSCUT HANDSAW COMES WITH A PROTECTIVE FULL-LENGTH SLEEVE. 8 POINTS PER INCH.

STOCK NO. **STW15726**

### HACKSAW FRAMES

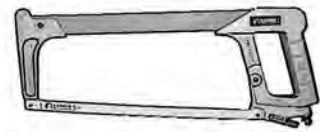

NO. 4012 HI-TENSION HACKSAW FRAME. WITH 12" BLADE. TENSION TO 30,000 PSI. HEAVY-DUTY. BLADE CAN BE MOUNTED AT A 45 DEGREE ANGLE FOR FLUSH JOBS. SPARE BLADE STORAGE INSIDE TUBULAR BACK.

STOCK NO. **LEN20918**

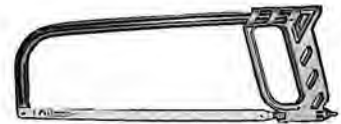

NO. 2012 STANDARD HACKSAW FRAME. WITH 12" BLADE. RUGGED YET ECONOMICAL.

STOCK NO. **LEN20919**

### PVC SAW



HAND SAW DESIGNED ESPECIALLY TO CUT PVC AND ABS PLASTIC PIPE WITHOUT BINDING. CAN ALSO DO OTHER GENERAL CUTTING OF PLASTIC AND WOOD. CUTS ON BOTH PUSH AND PULL STROKES. DIE-CAST ALUMINUM HANDLE. 18" BLADE.

STOCK NO. **LEN20980**

18" REPLACEMENT BLADE

STOCK NO. **LEN20981**

### POWER HACKSAW BLADES



BI-METAL CONSTRUCTION PERMITS FULL, HARD TOOTH FOR LONGER, FASTER CUTTING WITH LOWEST COST PER CUT.

STANDARD: (S)  
VARI-TOOTH: (VT)

STOCK NO.	SIZE	TYPE	TEETH PER INCH
LEN22011	12" x 1" x .050	S	14
LEN22017	14" x 1" x .050	S	10
LEN22018	14" x 1" x .050	S	14
LEN22155	14" x 1-1/4 x .062	VT	4/6
LEN22022	14" x 1-1/4 x .062	S	6
LEN22123	14" x 1-1/4 x .062	VT	6/10
LEN22023	14" x 1-1/4 x .062	S	10
LEN22026	14" x 1-1/2 x .062	S	4
LEN22027	14" x 1-1/2 x .062	S	6
LEN22050	18" x 1-1/4 x .062	S	6
LEN22051	18" x 1-1/4 x .062	S	10
LEN22054	18" x 1-1/2 x .075	S	4
LEN22055	18" x 1-1/2 x .075	S	6
LEN22060	18" x 1-3/4 x .088	S	4
LEN22061	18" x 1-3/4 x .088	S	6
LEN22069	21" x 1-3/4 x .088	S	4
LEN22070	21" x 1-3/4 x .088	S	6



**CIRCULAR SAW BLADES**



IRWIN, AN AMERICAN TOOL COMPANY, OFFERS QUALITY BLADES MADE OF THE FINEST ALLOY SAW STEEL. PRECISION GROUND TO EXACTING STANDARDS. BLADES TEMPERED AND HARDENED TO ELIMINATE WARPING. BLADES CAN BE RESHARPENED.

**CHISEL TOOTH COMBINATION**



MOST POPULAR ALL-PURPOSE BLADE FOR RIPPING AND CROSS-CUT. SMALL NUMBER OF TEETH FOR FAST CUTTING WHERE SMOOTH FINISH IS NOT NEEDED. IDEAL FOR HOUSE FRAMING. 7-1/4" DIAMETER. UNIVERSAL ARBOR HOLE. 1 PER PACK.

STOCK NO. HAN11040

**STANDARD COMBINATION**



BEST COMBINATION BLADE FOR BOTH CUT-OFF AND RIP. BLADES PROVIDE A SMOOTHER FINISH WITH LITTLE LOSS IN SPEED. 7-1/4" DIAMETER. UNIVERSAL ARBOR HOLE. 1 PER PACK.

STOCK NO. HAN11140

**MASTER COMBINATION**



THE BEST COMBINATION FOR SMOOTH CUTS. ALL-PURPOSE GENERAL CUTTING BLADE FOR SMOOTH, FAST CUTS. RIP, CROSS-CUT, AND MITERS. 7-1/4" DIAMETER. UNIVERSAL ARBOR HOLE. 1PER PACK.

STOCK NO. HAN11240

**PLYWOOD/PANELING**



SMOOTH, CLEAN CUTTING IN PLYWOOD, PANELING AND VENEER. LARGE NUMBER OF TEETH REDUCES SPLINTERING. 7-1/4" DIAMETER, UNIVERSAL ARBOR HOLE. 1 PER PACK

STOCK NO. HAN11840

10" DIAMETER. 5/8" ARBOR HOLE.  
STOCK NO. HAN11870

**CALL IN  
YOUR ORDER  
FOR  
PROMPT,COURTEOUS  
ASSISTANCE!**

**CARBIDE TIPPED SAW BLADES**

FREUD CARBIDE TIPPED BLADES FIT ALL POPULAR PORTABLE, TABLE AND RADIAL SAWS. SMOOTHER, LONGER LASTING PRECISION-GROUND CARBIDE TEETH. STAYS SHARP UP TO 50 TIMES MORE THAN STEEL BLADES.

**PROFESSIONAL CONSTRUCTION FRAMING LUMBER BLADES**



ANTI-KICKBACK DESIGN

STOCK NO.	DIA.	ARBOR	TEETH
FRTK103	7-1/4"	5/8"	16
FRTK203	7-1/4"	5/8"	24
FRTK204	8-1/4"	5/8"	24
FRTK206	10"	5/8"	24

**FINISHING BLADES**



THE CROSSCUTTING, RIPPING AND PLYWOD BLADE. ANTI-KICKBACK DESIGN. SMOOTH CUT.

STOCK NO.	DIA.	ARBOR	TEETH
FRTK303	7-1/4"	5/8"	40
FRTK304	8"	5/8"	40
FRTK306	10"	5/8"	40
FRTK406	10"	5/8"	60

CARBIDE TIPPED CIRCULAR BLADES  
CONTINUED NEXT COLUMN

**REMODELING/NAIL CUTTING BLADE**



HANDLES UNSEEN HAZARDS SUCH AS NAIL-EMBEDDED WOOD. ANTI-KICKBACK DESIGN.

STOCK NO.	DIA.	ARBOR	TEETH
FRTK503	7-1/4"	5/8"	14

**COMBINATION BLADES**



IDEALCOMBINATION BLADES FOR RIP, CROSS-CUT, CHIP BOARD AND PLYWOOD. ANTI-KICKBACK DESIGN.

STOCK NO.	DIA.	ARBOR	TEETH
FRTK903	7-1/4"	5/8"	30
FRTK905	9"	5/8"	40
FRTK906	10"	5/8"	50
FRLU84M012	12"	1"	60

**NON-FERROUS BLADES**



CUTS THROUGH ALUMINUM, BRASS AND OTHER NON-FERROUS METALS. UNIQUE GULLET PREVENTS CHIP BUILD-UP WHICH CAN CAUSE SHOULDER DAMAGE.

STOCK NO.	DIA.	ARBOR	TEETH
FRLU89M010	10"	5/8"	72

**ECONOMICAL "THROW-AWAY" CARBIDE TIPPED BLADES**

STOCK NO.	DIA.	ARBOR	TEETH
X200	7-1/4"	5/8"	24

ADDITIONAL SIZES AND STYLES OF CIRCULAR SAW BLADES AVAILABLE UPON REQUEST

## CARBIDE ROUTER AND BORING BITS

### STRAIGHT BITS

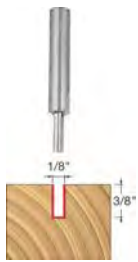

TWO FLUTES FOR SMOOTH CUTTING IN ABRASIVE OR HARD MATERIALS. SPECIAL RELIEVED END DESIGN ENABLES EASY PLUNGING. WORKS WELL IN AUTOMATIC OR MANUAL ROUTERS.

STOCK NO.	CUTTING DIA.	CUTTING LENGTH	SHANK DIA.	OVERALL LENGTH
FR04100	1/8	3/8	1/4	1-3/4
FR04106	1/4	3/4	1/4	2-1/4
FR04108	1/4	1"	1/4	2-1/2
FR04126	3/8	1-1/4	1/4	2-3/4
FR12122	1/2	1-1/2	1/2	3-1/8
FR11180*	1/2	2-1/2	1/2	4-3/8
FR04140	3/4	3/4	1/4	2-1/8

\*SINGLE FLUTE

### MORTISING BITS



DEEP CENTER GULLET ALLOWS MAXIMUM MATERIAL REMOVAL. IDEAL BITS TO USE WITH TEMPLATES FOR SETTING BUTT HINGES.

STOCK NO.	CUTTING DIA.	CUTTING LENGTH	SHANK DIA.	OVERALL LENGTH
FR16100	1/2	1/2	1/4	2"

### ROUND NOSE BITS



GIVES A PERFECT RADIUS, FREE OF CHIPPING. IDEAL TO CUT DECORATIVE DESIGNS IN CABINET DOORS AND FOR PATTERNMAKING.

STOCK NO.	CUTTING DIA.	CUTTING LENGTH	SHANK DIA.	OVERALL LENGTH
FR18104	1/4	3/8	1/4	2"
FR18106	3/8	3/8	1/4	1-13/16

ADDITIONAL SIZES AND BITS AVAILABLE UPON REQUEST

### V-GROOVING BITS



90° V-GROOVING BITS CREATE DEEP OR SHALLOW GROOVES IN HARD OR SOFT MATERIALS. USED IN SIGN MAKING AND AS A DECORATIVE ACCENT ON FURNITURE AND PLAQUES.

STOCK NO.	CUTTING DIA.	CUTTING LENGTH	SHANK DIA.	OVERALL LENGTH
FR20100	1/4	1/4	1/4	1-1/2
FR20104	1/2	1/2	1/4	1-3/4

### DOVETAIL BITS



EXCELLENT RESULTS IN SOLID WOOD, PLYWOOD, LAMINATES AND COMPOSITION MATERIALS. IDEAL FOR MAKING FURNITURE.

STOCK NO.	CUTTING DIA.	CUTTING LENGTH	SHANK DIA.	DEGREE EA. SIDE
FR22104	1/2	1/4	1/4	14°

### PANEL PILOT BIT WITH PLUNGE POINT



THE DRILL POINT ALLOWS SELF-STARTING AND THE PILOT FEATURE ACTS AS A GUIDE FOR CUT-OUT WORK. IDEAL FOR TEMPLATES.

STOCK NO.	CUTTING DIA.	CUTTING LENGTH	SHANK DIA.	OVERALL LENGTH
FR26100	1/4	3/4	1/4	2-1/4
FR26104	1/2	1-1/4	1/2	3-3/3

ADDITIONAL SIZES AND BITS AVAILABLE UPON REQUEST

### COVE BITS



A SPECIAL UP-SHEAR CUTTING ANGLE ALLOWS FAST, SMOOTH CUTTING IN HARD AND SOFT WOODS. BALL-BEARING PILOT.

STOCK NO.	RADIUS	LARGE DIA.	SHANK DIA.	DEPTH OF CUT
FR30102	1/4	7/8	1/4	1/2
FR30106	1/2	1-3/8	1/4	5/8

### RABBETING BITS



CUTS A CLEAN EDGE STEP IN HARD & SOFT WOODS AND COMPOSITIONS. IDEAL FOR LAP JOINTS, PICTURE FRAME BACKS AND CABINET DOORS. RELIEVED TOP AND BOTTOM FOR FASTER CUTTING.

STOCK NO.	LARGE DIA.	DEPTH OF RABBET	SHANK DIA.	CUTTING EDGE
FR32100	1-1/4	3/8	1/4	1/2
FR32102	1-1/4	3/8	1/2	1/2

### ROUNDING-OVER BITS



HIGH RADIAL CUTTING ANGLES FOR FAST CHIP EJECTION AND SMOOTH CUTTING. STAINLESS STEEL NON-MARRING BALL BEARING PILOT IS SHIELDED FOR LONG LIFE.

STOCK NO.	RADIUS	LARGE DIA.	SHANK DIA.	CARBIDE HEIGHT
FR34110	1/4	1"	1/4	1/2
FR34114	3/8	1-1/4	1/4	1/2

CARBIDE ROUTER AND BORING BITS CONTINUED NEXT PAGE

**CARBIDE ROUTER AND BORING BITS**

**BEADING BITS**



MANUFACTURED WITH HIGH RADIAL ANGLES FOR FAST CHIP REJECTION AND SMOOTH FINISH. NON-MARRING BALL BEARING IS SHIELDED FOR LONGER LIFE. USED TO PRODUCE AN ATTRACTIVE BEAD PROFILE TO FURNITURE AND MILLWORK.

STOCK NO.	RADIUS	LARGE DIA.	SHANK DIA.	CARBIDE HEIGHT
FR36110	1/4	1"	1/4	1/2
FR36114	3/8	1-1/4	1/4	1/2

*ADDITIONAL SIZES AND BITS AVAILABLE UPON REQUEST*

**ROMAN OGEE BITS**



EXTREMELY PRECISION-MADE FOR HIGH PERFORMANCE ROUTING WITH CLASSICAL STYLING. FOR SIGN MAKING, PLAQUES, FURNITURE MAKING AND CABINET- MAKING. CUTS WELL IN SOLID WOOD AND COMPOSITIONS.

STOCK NO.	LARGE RADIUS	OVERALL DIA.	SHANK DIA.	CARBIDE HEIGHT
FR38100	5/32	1-1/16	1/4	1/2
FR38102	1/4	1-3/8	1/4	23/32

**CHAMFER BIT**



FORMS A UNIFORM CHAMFER ON THE EDGE OF THE WORK PIECE TO ADD CHARACTER WHILE KEEPING CRISP GEOMETRIC LINES. THE SIZE OF THE CHAMFER MAY BE ADJUSTED BY RAISING OR LOWERING THE BIT.

STOCK NO.	DEGREE ANGLE	CARBIDE LENGTH	SHANK DIA.	OVERALL LENGTH
FR40106	45°	1"	1/4	1-3/4

*ADDITIONAL SIZES AND BITS AVAILABLE UPON REQUEST*

**BEARING FLUSH TRIM BITS**



SMOOTH, BURN-FREE CUTS FOR TRIM WORK. CUTS ALL LAMINATES, COMPOSITION MATERIALS, PLYWOOD, HARD AND SOFT WOODS.

STOCK NO.	OVERALL DIA.	CARBIDE HEIGHT	SHANK DIA.	OVERALL LENGTH
FR42100	3/8	1"	1/4	2-13/16
FR42104	1/2	1"	1/4	2-13/16
FR42106	1/2	1/2	1/4	2-1/8

**SOLID CARBIDE TRIM BITS**



SELF-PILOTING BITS GET INTO TIGHTER SPOTS THAN BEARING-GUIDED BITS. THE FLUSH BIT HAS A 3/8" CUTTING EDGE. THE BEVEL BIT FEATURES A 7° BEVEL FOR PERFECT EDGE TRIMMING.



**FLUSH BIT**

STOCK NO.	OVERALL DIA.	CARBIDE HEIGHT	SHANK DIA.	OVERALL LENGTH
FR64100	1/4	3/8	1/4	1-1/2

**BEVEL BIT**

STOCK NO.	OVERALL DIA.	CARBIDE HEIGHT	SHANK DIA.	OVERALL LENGTH
FR66100	1/4	1/4	1/4	1-1/2

*OUR STAFF IS READY TO TAKE YOUR CALL*



THIS IS A COMPREHENSIVE CATALOG OF OUR MAJOR LINES AND SERVICES, BUT IT DOES NOT SHOW ALL AVAILABLE PRODUCT LINES. IF THERE IS SOMETHING YOU NEED THAT IS NOT SHOWN, GIVE US A CALL. WE EITHER CARRY IT OR CAN GET IT FOR YOU.

**CONSULT  
 OUR  
 DETAILED  
 CATALOG INDEX  
 FOR  
 EASY-REFERENCE**



### SWISS PATTERN NEEDLE FILES

#### BARRETTE

	CUTS 00	0	2	4	6
4"		GR314501	31451	31452	
5-1/2"		31453	31454	31456	
6-1/4"	GR314581	GR314591	31461	31463	31464

#### CROSSING

	CUTS 00	0	2	4	6
4"		31484	31485	31486	
5-1/2"		31487	31488	31489	
6-1/4"		31490	31491	31492	31493

#### EQUALLING

	CUTS 00	0	2	4	6
4"		31498	31499	31500	
5-1/2"		GR31501	31502	31503	
6-1/4"	31505	31506	31508	31510	31511

#### HALF-ROUND

	CUTS 00	0	2	4	6
4"		GR315161	31517	31518	
5-1/2"		31519	31520	31522	
6-1/4"	GR315241	GR315251	31527	31529	31530

#### 6 PC. CROSS CUT FILE SET



STOCK NO. GR32510

#### ESCAPEMENT FILES

ESCAPEMENT FILES (OR SQUARE HANDLE NEEDLE FILES) ARE USED IN FINE WATCH-MAKING, IN FINISHING FINE EXTRUSION DIES, AND FOR FINE JEWELRY REPAIR WORK. LENGTH OF CUT: 1-9/16" TO 2-9/16" ACCORDING TO SHAPE. OVERALL LENGTH: 5-1/2".

MANY OTHER STYLES AND CUTS ARE AVAILABLE UPON REQUEST.

#### HALF ROUND

	CUTS 0	2	4	6	8
5-1/2"	GR317241	31725	31727	31728	31729

#### SQUARE

	CUTS 0	2	4	6	8
5-1/2"	GR317541	31755	31756	31757	31758

FOR MORE EFFICIENT WILL-CALL SERVICE, PLEASE CALL AHEAD WITH YOUR ORDER.

STOCK ITEMS BEGIN WITH A GR OR P PREFIX OTHERS AVAILABLE UPON REQUEST

NEEDLE FILES ARE USED FOR APPLICATIONS SIMILAR TO LARGER TANG FILES. HANDLES ARE KNURLED TO PERMIT A POSITIVE, SURE GRIP FOR PRECISION FILING. USED FOR PRODUCTION WORK ON SMALL AND ELECTRONIC PARTS.

OVERALL LENGTHS: 4", 5-1/2", 6-1/4", 7-3/4". LENGTH OF CUT: 1-3/4", 2-1/2", 3", 4-1/8".

#### SCALE OF CUT

TEETH PER INCH: 41 64 97 117 142 213 (UP-CUT)  
FILES 4" - 7-3/4" 00 0 2 3 4 6

#### COMPARABLE CUT DESIGNATIONS

SWISS PATTERN	AMERICAN PATTERN
NO. 00	BASTARD
NO. 0	SECOND
NO. 2	SMOOTH

THERE IS NO EQUIVALENT IN AMERICAN PATTERN FILES FOR SWISS CUTS No. 4 to No. 8.

#### HOT DIE FILES



WIDELY USED IN MAKING AND REPAIRING EXTRUSION DIES. BARRETTE, GROUND BACK STYLE IS A STOCK ITEM. OTHERS ARE AVAILABLE UPON REQUEST.

STOCK NO.	LENGTH	CUT
31693	5-1/2"	0
GR316941	6-1/4"	0

#### PLASTIC FILE HANDLES



ANATOMICALLY WELL-FORMED WITH GRIPPING EDGE WHICH PREVENTS SLIPPING. HOLLOW IN THE HANDLE HELP INCREASE THE HOLD. ECONOMICAL- CAN BE REUSED OVER AGAIN. FOR FILE LENGTHS 4-6" WITH VERY NARROW TANGS AND FOR KEY FILES.

STOCK NO. P11130

#### NEEDLE FILE HANDLE



THIS HANDLE HAS A CLAMPING MECHANISM WHICH, BY TURNING THE UPPER AND LOWER PART OF THE HANDLE, MAKES EASY CLAMPING POSSIBLE OF NEEDLE AND KEY FILES.

STOCK NO. P16074

#### ROUND

	CUTS 00	0	2	4	6
4"		GR315821	31583	31584	
5-1/2"		31585	31586	31588	
6-1/4"	31590	GR315911	31593	31595	31596

#### SQUARE

	CUTS 00	0	2	4	6
4"		GR316121	31613	31614	
5-1/2"		31615	31616	31617	
6-1/4"	31619	GR316201	31622	31624	31625

#### THREE-SQUARE

	CUTS 00	0	2	4	6
4"		GR316301	31631	31632	
5-1/2"		31633	31634	31636	
6-1/4"	31637	31638	31640	31642	31643

#### JOINT, ROUND EDGE

	CUTS 00	0	2	4	6
4"		31537	31538	31539	
5-1/2"		31540	31541	31542	
6-1/4"		GR315431	31544	31545	31546

#### DIAMOND FILES

FOR FILING OF HARDENED STEEL AND TUNGSTEN CARBIDE MATERIAL IN THE MANUFACTURE OF CUTTING DIES, PUNCHING AND PRESS TOOLS. GUARANTEED HIGH STOCK REMOVAL. OVERALL LENGTH: 5-1/2".

MANY OTHER STYLES AND CUTS ARE AVAILABLE UPON REQUEST.

#### EQUALLING



STOCK NO. P04001 (COARSE GRIT)  
STOCK NO. 04014 (MEDIUM GRIT)  
STOCK NO. 04027 (FINE GRIT)

#### SQUARE



STOCK NO. P04005 (COARSE GRIT)  
STOCK NO. 04018 (MEDIUM GRIT)  
STOCK NO. 04031 (FINE GRIT)

#### ROUND



STOCK NO. P04007 (COARSE GRIT)  
STOCK NO. 04020 (MEDIUM GRIT)  
STOCK NO. 04033 (FINE GRIT)

#### BARRETTE



STOCK NO. P04011 (COARSE GRIT)  
STOCK NO. 04024 (MEDIUM GRIT)  
STOCK NO. 04037 (FINE GRIT)  
STOCK NO. SDI2102TBC\* (COARSE GRIT)  
STOCK NO. SDI2102TBM\* (MEDIUM GRIT)  
STOCK NO. SDI2102TBF\* (FINE GRIT)

\* OVERALL LENGTH 6-1/4



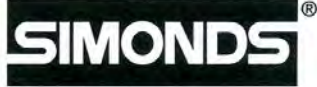

AMERICAN PATTERN FILES



FLAT



FLAT FILES ARE TAPERED IN WIDTH AT THE POINT AND SLIGHTLY TAPERED IN THICKNESS AT THE POINT. THEY ARE DOUBLE CUT ON BOTH SIDES AND SINGLE CUT ON BOTH EDGES. USED EXTENSIVELY BY MACHINISTS ON FERROUS AND NON-FERROUS METALS FOR RAPID STOCK REMOVAL.

STOCK NO.	CUT	APPROX. SIZE
F227000	BASTARD	4" x 13/32 x 3/32
F229500	BASTARD	6" x 5/8 x 5/32
F232000	BASTARD	8" x 25/32 x 7/32
F234000	BASTARD	10" x 31/32 x 1/4
F236000	BASTARD	12" x 1-5/32 x 9/32
F238000	BASTARD	14" x 1-11/32 x 5/16
F227500	SECOND	4" x 13/32 x 3/32
F230000	SECOND	6" x 5/8 x 5/32
F232500	SECOND	8" x 25/32 x 7/32
F234500	SECOND	10" x 31/32 x 1/4
F236500	SECOND	12" x 1-5/32 x 9/32
-	SECOND	14" x 1-11/32 x 5/16
F228000	SMOOTH	4" x 13/32 x 3/32
F230500	SMOOTH	6" x 5/8 x 5/32
F233000	SMOOTH	8" x 25/32 x 7/32
F235000	SMOOTH	10" x 31/32 x 1/4
F237000	SMOOTH	12" x 1-5/32 x 9/32
-	SMOOTH	14" x 1-11/32 x 5/16

KNIFE



SHAPED LIKE A KNIFE BLADE, THIS FILE IS COMMONLY USED ON SLOTS AND KEYWAYS AND FOR ACUTE ANGLE WORK IN DIE MAKING. SIDES ARE DOUBLE CUT AND THIN EDGE IS CUT. BACK IS SAFE (UNCUT).

STOCK NO.	CUT	APPROX. SIZE
-	BASTARD	4" x 15/32 x 7/64
F500000	BASTARD	6" x 21/32 x 5/32
-	BASTARD	8" x 27/32 x 3/16
F503000	BASTARD	10" x 1-1/32 x 1/4
-	SECOND	4" x 7/16 x 5/64
-	SECOND	6" x 21/32 x 5/32
F502000	SECOND	8" x 27/32 x 3/16
F503500	SECOND	10" x 1-1/32 x 1/4
-	SMOOTH	4" x 15/32 x 7/64
F501000	SMOOTH	6" x 21/32 x 5/32
F502500	SMOOTH	8" x 27/32 x 3/16
-	SMOOTH	10" x 1-1/32 x 1/4

FLAT BABBITT



BOTH SIDES ARE STANDARD CUT ON THIS CURVED TOOTH FILE. EXACTLY LIKE FLAT FILES IN SHAPE AND SIZE, BUT WITH FEWER TEETH PER INCH.

STOCK NO.	APPROX. SIZE
-	12" x 1-5/32 x 17/64
F134000	14" x 1-11/32 x 5/16

HALF-ROUND



HALF-ROUND FILES ARE ROUNDED ON ONE SIDE AND FLAT ON THE OTHER. DOUBLE CUT FOR FAST STOCK REMOVAL ON CONCAVE, CONVEX AND FLAT SURFACES. THE FILE TAPERS TOWARD THE POINT IN BOTH WIDTH AND THICKNESS.

STOCK NO.	CUT	APPROX. SIZE
-	BASTARD	4" x 7/16 x 1/8
F317000	BASTARD	6" x 19/32 x 5/32
F319000	BASTARD	8" x 3/4 x 7/32
F321000	BASTARD	10" x 15/16 x 9/32
F323000	BASTARD	12" x 1-1/8 x 11/32
NICH05190	BASTARD	14" x 1-9/32 x 13/32
F315500	SECOND	4" x 7/16 x 1/8
F317500	SECOND	6" x 19/32 x 5/32
F319500	SECOND	8" x 3/4 x 7/32
F321500	SECOND	10" x 15/16 x 9/32
F323500	SECOND	12" x 1-1/8 x 11/32
-	SECOND	14" x 1-9/32 x 13/32
F316000	SMOOTH	4" x 7/16 x 1/8
F318000	SMOOTH	6" x 19/32 x 5/32
F320000	SMOOTH	8" x 3/4 x 7/32
F322000	SMOOTH	10" x 15/16 x 9/32
F324000	SMOOTH	12" x 1-1/8 x 11/32
-	SMOOTH	14" x 1-9/32 x 13/32

LONG ANGLE LATHE



A RAPID, FREE-CUTTING FILE DESIGNED FOR SMOOTH FINISH LATHE WORK ON EITHER HARD OR SOFT METALS. THIS SINGLE CUT FILE HAS TEETH CUT ON A LONG ANGLE WITH SAFE EDGES TO PROTECT THE SHOULDER OR DOG. IT TAPERS IN WIDTH TOWARD THE POINT.

STOCK NO.	APPROX. SIZE
F255500	10" x 31/32 x 1/4
F256000	12" x 1-5/32 x 9/32
F256500	14" x 1-11/32 x 5/16

WOOD RASP HAND



USED BY WOOD WORKERS FOR VERY ROUGH CUTTING. FLAT RASP AND BLUNT IN SHAPE WITH NO TAPER. CUT SIDES.

STOCK NO.	CUT	APPROX. SIZE
-	BASTARD	6" x 5/8 x 5/32
-	BASTARD	8" x 25/32 x 13/64
F107080	BASTARD	10" x 1" x 1/4
F113080	BASTARD	12" x 1-5/32 x 7/16
-	SECOND	8" x 25/32 x 13/64
-	SECOND	10" x 1" x 1/4

ALL PURPOSE



A VERSATILE FILE THAT IS SINGLE CUT ON ONE SIDE AND DOUBLE CUT ON THE OTHER WITH A BUILT IN HANDLE, EXCELLENT FOR A VARIETY OF SHARPENING.

STOCK NO.	CUT	APPROX. SIZE
F187500	-	8" x 31/32 x 3/16

GREAT AMERICAN CROSSCUT



WEDGE-SHAPED WITH A ROUNDED CUT BACK, AND ORIGINALLY MADE FOR SHARPENING GREAT AMERICAN TYPE OF CROSS CUT SAWS. THE ROUNDED BACK IS USED TO DEEPEN ROUNDED GULLETS OF SAW TEETH AND THE SIDES ARE USED FOR FILING THE TEETH. SINGLE CUT W/ TEETH CUT ALONG THIN EDGE.

STOCK NO.	APPROX. SIZE
F512000	8" x 11/16 x 9/32
F512500	10" x 13/16 x 23/64

MASTER CUT



MASTER CUT FILES HAVE GROUND-IN CHIP BREAKERS, MAKING THEM THE MOST VERSATILE MACHINISTS-TYPE FILE AVAILABLE. REMOVES STOCK RAPIDLY, YET LEAVES A SMOOTH SURFACE. IT MAY BE USED ON PLASTIC, BRASS, STEEL, CAST IRON OR ALMOST ANY METAL. UNIFORM IN THICKNESS, IT TAPERS IN WIDTH TOWARD THE POINT.

STOCK NO.	APPROX. SIZE
-	8" x 25/32 x 7/32
F243500	10" x 31/32 x 1/4
F244000	12" x 1-5/32 x 9/32

MILL



MILL FILES ARE USED FOR SHARPENING SAWS AND MANY OTHER TYPES OF CUTTING TOOLS. SUITABLE BOTH AS AN ENGINEERING AND SHARPENING FILE. USEFUL WHERE A SMOOTH FINISH IS IMPORTANT. ALSO GOOD FOR POLISHING AND DEBURRING WORK IN LATHES. TWO SQUARE EDGES. SINGLE CUT ON SIDES AND EDGES. ALL SIZES SLIGHTLY TAPERED IN WIDTH.

STOCK NO.	CUT	APPROX. SIZE
F140500	BASTARD	4" x 7/16 x 5/64
F143000	BASTARD	6" x 19/32 x 7/64
F145500	BASTARD	8" x 25/32 x 9/64
F147500	BASTARD	10" x 31/32 x 11/64
F149500	BASTARD	12" x 1-5/32 x 7/32
P151500	BASTARD	14" x 1-5/16 x 1/4
-	SECOND	4" x 7/16 x 5/64
F143500	SECOND	6" x 19/32 x 7/64
F146000	SECOND	8" x 25/32 x 9/64
F148000	SECOND	10" x 31/32 x 11/64
F150000	SECOND	12" x 1-5/32 x 7/32
F152000	SECOND	14" x 1-5/16 x 1/4
-	SMOOTH	4" x 7/16 x 5/64
F144000	SMOOTH	6" x 19/32 x 7/64
F146500	SMOOTH	8" x 25/32 x 9/64
F148500	SMOOTH	10" x 31/32 x 11/64
F150500	SMOOTH	12" x 1-5/32 x 7/32
F152500	SMOOTH	14" x 1-5/16 x 1/4

**SIMONDS**<sup>®</sup>
**AMERICAN PATTERN FILES & ACCESSORIES**
**SIMONDS**<sup>®</sup>
**ROUND**

DESIGNED FOR ENLARGING CIRCULAR HOLES OR ROUNDED GROOVES TOO SMALL FOR A HALF ROUND FILE. IT TAPERS TOWARD THE POINT, MAKING IT ADAPTABLE FOR USE ON VARIOUS HOLE SIZES.

STOCK NO.	CUT	APPROX. SIZE
F393000	BASTARD	4" x 5/32
F396000	BASTARD	6" x 7/32
F398500	BASTARD	8" x 5/16
F400500	BASTARD	10" x 3/8
F402500	BASTARD	12" x 1/2
F404500	BASTARD	14" x 5/8
F393500	SECOND	4" x 5/32
F396500	SECOND	6" x 7/32
F399000	SECOND	8" x 5/16
F401000	SECOND	10" x 3/8
F403000	SECOND	12" x 1/2
-	SECOND	14" x 5/8
F394000	SMOOTH	4" x 5/32
F397000	SMOOTH	6" x 7/32
F399500	SMOOTH	8" x 5/16
F401500	SMOOTH	10" x 3/8
F403500	SMOOTH	12" x 1/2
-	SMOOTH	14" x 5/8

**THREE SQUARE**

THREE SQUARE FILES ARE TRIANGULAR IN CROSS SECTION, BUT ARE DOUBLE CUT. THEY ALSO HAVE FAIRLY SHARP CORNERS THAT ARE SLIGHTLY SET AND CUT. THESE FILES ARE FOR GENERAL USE BY MACHINISTS FOR FILING INTERNAL ANGLES MORE ACUTE THAN THE RIGHT ANGLE. THEY ARE ALSO USED FOR CLEARING OUT SQUARE CORNERS AND FILING TAPS AND CUTTERS.

STOCK NO.	CUT	APPROX. SIZE
F516500	BASTARD	6" x 15/32
F518000	BASTARD	8" x 5/8
F519500	BASTARD	10" x 3/4
-	BASTARD	12" x 27/32
-	SECOND	6" x 15/32
F518500	SECOND	8" x 5/8
F520000	SECOND	10" x 3/4
F517500	SMOOTH	6" x 15/32
F519000	SMOOTH	8" x 5/8
F520500	SMOOTH	10" x 3/4

CONSULT OUR  
DETAILED CATALOG INDEX  
FOR EASY REFERENCE

**SQUARE**

SQUARE FILES ARE HANDY FOR FILING SLOTS, KEYWAYS AND GENERAL SURFACE FILING. THE LARGER SIZES ARE FREQUENTLY PREFERRED OVER CORRESPONDING FLAT FILES BECAUSE OF THE HEAVIER SECTION AND FOUR EQUAL FILING SURFACES. DOUBLE CUT, IT TAPERS TOWARD THE POINT.

STOCK NO.	CUT	APPROX. SIZE
-	BASTARD	4" x 5/32
-	BASTARD	6" x 7/32
-	BASTARD	8" x 5/16
-	BASTARD	10" x 3/8
-	BASTARD	12" x 1/2
-	SECOND	4" x 5/32
-	SECOND	6" x 7/32
F430500	SECOND	8" x 5/16
-	SECOND	10" x 3/8
-	SECOND	12" x 1/2
-	SMOOTH	4" x 5/32
-	SMOOTH	6" x 7/32
-	SMOOTH	8" x 5/16
-	SMOOTH	10" x 3/8
-	SMOOTH	12" x 1/2

**LONG FERRULE FILE HANDLES**

STOCK NO.	SIZE	FITS FILE	LENGTH x DIA.
OPL29542	#2	6" to 8"	4-1/2 x 1-3/16
OPL29543	#3	8" to 12"	5" x 1-5/16
OPL29544	#4	12" to 16"	5-1/2 x 1-7/16
-	#5	16" to 20"	6" x 1-9/16

**SKROO-ZON FILE HANDLES**

WHITE BIRCH HANDLE AND HEAVY STEEL GAUGE FERRULE. PREFERRED BY MANY BECAUSE THE FILE SCREWS ONTO A HARDENED STEEL INSERT INSIDE THE HANDLE.

STOCK NO.	SIZE	FITS FILE	LENGTH x DIA.
LFT10202	#T2	4"	3-1/2 x 1-1/16
LFT10204	#T4	6"	4" x 1-1/8
LFT10205	#T5	8"	4-1/2 x 1-1/4
LFT10206	#T6	10"	4-1/2 x 1-1/4
LFT10207	#T7	12"	5" x 1-3/8
LFT10208	#T8	14"	5" x 1-3/8

MANY OTHER FILES AND HANDLES ARE  
AVAILABLE UPON REQUEST

**TAPER**

TRIANGULAR IN SHAPE. SINGLE OR DOUBLE CUT AND TAPERED TOWARD THE POINT, THESE FILES ARE USED PRIMARILY FOR SHARPENING HAND SAWS, CIRCULAR SAWS, NARROW BAND, CROSS CUT AND BUCK SAWS. CUT EDGES OR CORNERS TO MAINTAIN SAW GULLETS.

STOCK NO.	CUT	APPROX. SIZE
F564500	DOUBLE	6" x 7/32
F553000	DOUBLE	6" x 9/32
F537000	SINGLE	6" x 11/32
F532500	DOUBLE	6" x 15/32
F565000	DOUBLE	7" x 1/4

**FILE CARD**

SHARP STEEL BRISTLES DIG AND REMOVE FILINGS FROM GROOVES OF FILES TO RESTORE THEIR CLEAN CUTTING CAPACITY.

STOCK NO.	NO.	SIZE
LFT20010	10	8-3/4"

**COMBINATION FILE CARD AND BRUSH**

BRUSH SIDE USED ESPECIALLY TO REMOVE FILINGS ON FINER CUT FILES.

STOCK NO.	NO.	SIZE
LFT20020	20	9-1/4"

**FILE SETS**

**5 PC. FILE SET WITH HANDLES** (8" FILES) MILL, ROUND, SQUARE, AND HALF ROUND BASTARD FILES, AND ONE FLAT MULTI-CUT.  
**STOCK NO. F75879**

**6 PC. FILE SET (WITHOUT HANDLES)** IMPORTED, PREMIUM-QUALITY SET INCLUDING 8" AND 12" FLAT BASTARD, 10" MILL BASTARD, 8" AND 8-1/2" ROUND BASTARD, AND 6" 3-SQUARE.  
**STOCK NO. X750**

**9 PC. FILE SET WITH HANDLES** (10" FILES) FLAT, HALF ROUND, ROUND, MILL, SQUARE BASTARDS, FLAT SMOOTH, HOBBY RASP, FILE CARD AND ONE 7" SLIM TAPER.  
**STOCK NO. F75881**

**SOLID CARBIDE ROTARY FILES  
1/4" DIAMETER SHANKS**

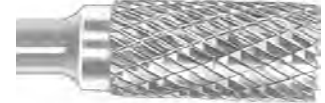
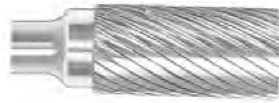
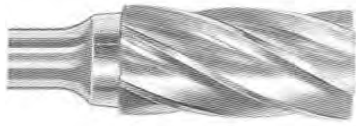

STOCK ITEM WITH **GR** PREFIX - OTHER AVAILABLE PER REQUEST

SELECTION OF THE TYPE OF CUT DEPENDS ON THE MATERIAL TO BE CUT, THE FINISH DESIRED AND THE BUR SHAPE ITSELF. STANDARD CUT IS MOST COMMONLY USED FOR GENERAL PURPOSE DEBURRING OF STEEL, CAST IRON AND OTHER FERROUS MATERIALS. ALL DIMENSIONAL LISTED BURS ARE STOCKED IN STANDARD CUT.

ALTERNATE DIAMOND CUT (ALT. DIA.) ALSO REFERRED TO AS DOUBLE CUT, DUPLICATES THE RIGHT HAND SPIRAL OF STANDARD CUT BUT FEATURES HALF AS MANY FLUTES IN THE LEFT HAND SPIRAL. THIS DESIGN PRODUCES A FINER FINISH ON MATERIAL WHILE REPRODUCING CHIPS AND SLIVERS. IT IS ALSO IDEAL WHERE GREATER TOOL CONTROL IS IMPORTANT AND IS RECOMMENDED OVER THE CHIP-BREAKER PATTERN. DIAMOND CHIP IS SIMILAR TO THE ALTERNATE DIAMOND CUT BUT HAS APPROXIMATELY THE SAME NUMBER OF TEETH IN THE LEFT HAND SPIRAL AS THE RIGHT HAND SPIRAL. THE TRIANGULAR STYLE OF TOOTH STRUCTURE DELIVERS A FINE FINISH WITH EXCELLENT TOOL CONTROL. CHIPS ARE NEARLY ELIMINATED BUT TOOL LIFE IS SHORT

**CYLINDRICAL-PLAIN END**



CUTTING HEAD DIA. x LENGTH	SCTI	STANDARD	SCTI	DOUBLE CUT	SCTI	DIAMOND
1/8 x 1/2	SA11	<b>GR325401</b>	SA11ADC	32541	SA11DM	32542
3/16 x 5/8	SA14	<b>GR325431</b>	SA14ADC	32544	SA14DM	32545
1/4 x 5/8	SA1	<b>GR325461</b>	SA1ADC	32547	SA1DM	<b>GR325481</b>
5/16 x 3/4	SA2	32549	SA2ADC	32550	SA2DM	32551
3/8 x 3/4	SA3	<b>GR325521</b>	SA3ADC	<b>GR32553</b>	SA3DM	<b>GR325541</b>
1/2 x 1"	SA5	<b>GR325551</b>	SA5ADC	32556	SA5DM	<b>GR325571</b>
5/8 x 1"	SA6	<b>GR325581</b>	SA6ADC	<b>GR32559</b>	SA6DM	32560
3/4 x 3/4	SA16	32561	SA16ADC	32562	SA16DM	32563
3/4 x 1"	SA7	32564	SA7ADC	32565	SA7DM	32566
1" x 1"	SA9	32567	SA9ADC	32568	SA9DM	32569

**BALL**



CUTTING HEAD DIAMETER	SCTI	STANDARD	SCTI	DOUBLE CUT	SCTI	DIAMOND
1/8	SD11	<b>GR326331</b>	SD11ADC	32634	SD11DM	32635
3/16	SD14	<b>GR326361</b>	SD14ADC	32637	SD14DM	32638
1/4	SD1	<b>GR326391</b>	SD1ADC	32640	SD1DM	<b>GR326411</b>
5/16	SD2	<b>GR326421</b>	SD2ADC	32644	SD2DM	32643
3/8	SD3	<b>GR326451</b>	SD3ADC	32646	SD3DM	<b>GR326471</b>
1/2	SD5	<b>GR326481</b>	SD5ADC	32649	SD5DM	32650
5/8	SD6	32651	SD6ADC	32652	SD6DM	32653
3/4	SD7	32654	SD7ADC	32655	SD7DM	32656

**CYLINDRICAL - END CUT**



CUTTING HEAD DIA. x LENGTH	SCTI	STANDARD	SCTI	DOUBLE CUT	SCTI	DIAMOND
1/8 x 1/2	SB11	32573	SB11ADC	32574	SB11DM	32575
1/8 x 9/16 x 3	SB43L3	-	SB43L3ADC	<b>GR3283933*</b>	SB43L3DM	-
3/16 x 5/8	SB14	32576	SB14ADC	<b>GR32577</b>	SB14DM	32578
1/4 x 5/8	SB1	<b>GR325791</b>	SB1ADC	32580	SB1DM	32581
5/16 x 3/4	SB2	32582	SB2ADC	32583	SB2DM	32584
3/8 x 3/4	SB3	<b>GR325851</b>	SB3ADC	<b>GR32586</b>	SB3DM	32587
1/2 x 1"	SB5	<b>GR325881</b>	SB5ADC	<b>GR32589</b>	SB5DM	32590
5/8 x 1"	SB6	32591	SB6ADC	<b>GR32592</b>	SB6DM	32593
3/4 x 3/4	SB16	32594	SB16ADC	32595	SB16DM	32596
3/4 x 1"	SB7	32597	SB7ADC	32598	SB7DM	32599
1" x 1"	SB9	32600	SB9ADC	32601	SB9DM	32602

**OVAL**



CUTTING HEAD DIA. x LENGTH	SCTI	STANDARD	SCTI	DOUBLE CUT	SCTI	DIAMOND
1/4 x 3/8	SE1	<b>GR326601</b>	SE1ADC	32661	SE1DM	32662
3/8 x 19/32	SE3	<b>GR326631</b>	SE3ADC	32664	SE3DM	<b>GR326651</b>
1/2 x 7/8	SE5	<b>GR326661</b>	SE5ADC	32667	SE5DM	32668
5/8 x 1"	SE6	32669	SE6ADC	32670	SE6DM	32671

\* 1/8 SHANK

**CYLINDRICAL-RADIUS END**



CUTTING HEAD DIA. x LENGTH	SCTI	STANDARD	SCTI	DOUBLE CUT	SCTI	DIAMOND
1/8 x 1/2	SC11	<b>GR326061</b>	SC11ADC	32607	SC11DM	32608
1/8 x 1/2	SC42	-	SC42ADC	<b>GR32848*</b>	SC42DM	-
3/16 x 5/8	SC14	<b>GR326091</b>	SC14ADC	32610	SC14DM	32611
1/4 x 5/8	SC1	<b>GR326121</b>	SC1ADC	32613	SC1DM	<b>GR326141</b>
5/16 x 3/4	SC2	<b>GR326151</b>	SC2ADC	32616	SC2DM	32617
3/8 x 3/4	SC3	<b>GR326181</b>	SC3ADC	<b>GR32619</b>	SC3DM	<b>GR326201</b>
1/2 x 1"	SC5	<b>GR326211</b>	SC5ADC	32622	SC5DM	<b>GR326231</b>
1/2 x 1" x 6"	SC5L6	-	SC5L6ADC	<b>GR3293758</b>	SC5L6DM	-
5/8 x 1"	SC6	<b>GR326241</b>	SC6ADC	<b>GR32625</b>	SC6DM	32626
3/4 x 1"	SC7	32627	SC7ADC	32628	SC7DM	32629

**FLAME**



CUTTING HEAD DIA. x LENGTH	SCTI	STANDARD	SCTI	DOUBLE CUT	SCTI	DIAMOND
5/16 x 3/4	SH2	<b>GR326751</b>	SH2ADC	<b>GR32676</b>	SH2DM	32677
1/2 x 1-1/4	SH5	<b>GR326781</b>	SH5ADC	<b>GR32679</b>	SH5DM	32680

**TREE POINTED**



CUTTING HEAD DIA. x LENGTH	SCTI	STANDARD	SCTI	DOUBLE CUT	SCTI	DIAMOND
1/4 x 5/8	SG1	<b>GR326841</b>	SG1ADC	32685	SG1DM	32686
3/8 x 3/4	SG3	<b>GR326871</b>	SG3ADC	<b>GR32688</b>	SG3DM	32689
1/2 x 3/4	SG13	<b>GR326901</b>	SG13ADC	32691	SG13DM	32692
1/2 x 1"	SG5	<b>GR326931</b>	SG5ADC	32694	SG5DM	32695
5/8 x 1"	SG6	32696	SG6ADC	32697	SG6DM	32698

## SOLID CARBIDE ROTARY FILES 1/4" DIAMETER SHANKS

### TREE RADIUS



CUTTING HEAD DIA. x LENGTH	SCTI	STANDARD	SCTI	DOUBLE CUT	SCTI	DIAMOND
1/4 x 5/8	SF1	<b>GR327021</b>	SF1ADC	32703	SF1DM	<b>GR327041</b>
3/8 x 3/4	SF3	<b>GR327051</b>	SF3ADC	<b>GR32706</b>	SF3DM	<b>GR327071</b>
1/2 x 1"	SF5	<b>GR327081</b>	SF5ADC	<b>GR32709</b>	SF5DM	<b>GR327101</b>
5/8 x 1"	SF6	<b>GR327111</b>	SF6ADC	32712	SF6DM	32713
3/4 x 1-1/4	SF14	32714	SF14ADC	32715	SF14DM	32716

### TREE RADIUS ALUMINUM CUT



CUTTING HEAD DIA. x LENGTH	SCTI	STANDARD	SCTI	DOUBLE CUT	SCTI	DIAMOND
1/2 x 1"	SF5NF	<b>GR3295717</b>	-	-	-	-

### CONE-RADIUS NOSE



CUTTING HEAD DIA. x LENGTH	SCTI	STANDARD	SCTI	DOUBLE CUT	SCTI	DIAMOND
1/4 x 5/8	SL1	<b>GR327201</b>	SL1ADC	32721	SL1DM	32722
5/16 x 7/8	SL2	<b>GR327231</b>	SL2ADC	32724	SL2DM	<b>GR327251</b>
3/8 x 1-1/16	SL3	<b>GR327261</b>	SL3ADC	32727	SL3DM	<b>GR327281</b>
1/2 x 1-1/8	SL4	32729	SL4ADC	32730	SL4DM	<b>GR327311</b>
5/8 x 1-5/16	SL6	32732	SL6ADC	32733	SL6DM	32734

### CONICAL



CUTTING HEAD DIA. x LENGTH	SCTI	STANDARD	SCTI	DOUBLE CUT	SCTI	DIAMOND
1/4 x 1/2	SM1	<b>GR327381</b>	SM1ADC	32739	SM1DM	32740
1/4 x 3/4	SM2	<b>GR327411</b>	SM2ADC	8052501	SM2DM	32743
1/4 x 1"	SM3	<b>GR327441</b>	SM3ADC	<b>GR327451</b>	SM3DM	32746
3/8 x 3/4	SM4	<b>GR327471</b>	SM4ADC	32748	SM4DM	32749
1/2 x 1"	SM5	<b>GR327501</b>	SM5ADC	32751	SM5DM	32753
5/8 x 1-1/8	SM6	32753	SM6ADC	32754	SM6DM	32755

### INVERTED CONE - PLAIN END



CUTTING HEAD DIA. x LENGTH	SCTI	STANDARD	SCTI	DOUBLE CUT	SCTI	DIAMOND
1/4 x 1/4	SN1	<b>GR327591</b>	SN1ADC	32760	SN1DM	32761
1/2 x 1/2	SN4	32762	SN4ADC	32763	SN4DM	32764

### INVERTED CONE - CONE-END CUT



CUTTING HEAD DIA. x LENGTH	SCTI	STANDARD	SCTI	DOUBLE CUT	SCTI	DIAMOND
1/4 x 1/4	SN1	GR327681	SN1ADC	32778	SN1DM	32779
1/2 x 1/2	SN4	GR327711	SN4ADC	32772	SN4DM	32773

### DEBURRING - 60°



CUTTING HEAD DIA. x LENGTH	SCTI	STANDARD	SCTI	DOUBLE CUT	SCTI	DIAMOND
1/4	SJ1	32777	SJ1ADC	32778	SJ1DM	32779
3/8	SJ3	32780	SJ3ADC	32781	SJ3DM	32782
1/2	SJ5	32783	SJ5ADC	32784	SJ5DM	32785

### DEBURRING - 90°



CUTTING HEAD DIA. x LENGTH	SCTI	STANDARD	SCTI	DOUBLE CUT	SCTI	DIAMOND
1/4	SK1	32789	SK1ADC	32790	SK1DM	32791
3/8	SK3	<b>GR327921</b>	SK3ADC	32793	SK3DM	32794
1/2	SK5	32795	SK5ADC	32796	SK5DM	32797
5/8	SK6	32798	SK6ADC	32799	SK6DM	32800
3/4	SK7	32801	SK7ADC	32802	SK7DM	32803
1"	SK9	32804	SK9ADC	32805	SK9DM	32806

**IF YOU NEED IT  
AND WE DON'T HAVE IT,  
IT'S OUR JOB TO GET IT FOR YOU!!**

**UTILITY RAZOR KNIVES, SCRAPPERS AND SPECIAL PURPOSE KNIVES**

**ADJUSTABLE MINI KNIFE**



TRIPLE CHROME PLATED CASE. TOP SLIDE, POCKET SIZED. KNIFE ONLY 3-1/4" LONG. RETRACTABLE BLADE LOCKS INTO TWO CUTTING POSITIONS. EXTRA BLADE IN HANDLE.

**STOCK NO. LSS63184**

**5 PK BLADES**

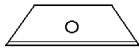

**STOCK NO. LSS63186**

**RETRACTABLE UTILITY KNIFE**



DIE-CAST ALL METAL UTILITY KNIFE. TOP SLIDE ADJUSTMENT. 3 POSITION RETRACTABLE BLADE. THREE HEAVY-DUTY BLADES INCLUDED.

**STOCK NO. USB11752B**

**SAFETY NOSE RETRACTABLE KNIFE**



HEAVY-DUTY RETRACTABLE UTILITY KNIFE. DESIGNED TO FIT THE HAND MORE COMFORTABLY. THE SAFETY NOSE OVERLAP ON BOTH TOP AND BOTTOM PROVIDES MORE SAFETY.

**STOCK NO. LFT30282**

**H. D. RETRACTABLE UTILITY KNIFE**



LOCKING AND UNLOCKING THE KNIFE IS QUICK AND EASY. NO TOOLS REQUIRED TO CHANGE BLADE. LARGE CONTOURED HANDLE FOR ULTIMATE COMFORT AND CONTROL. PLASTIC HOLSTER AND BELT CLIP FOR CONVENIENT AND SAFE USE.

**STOCK NO. X605**

**FIXED-BLADE UTILITY KNIFE**



DELUXE ALL METAL KNIFE. NON-ADJUSTABLE. THREE HEAVY-DUTY BLADES INCLUDED.

**STOCK NO. USB11799B**

**TIN COATED UTILITY KNIFE BLADE**



LASTS LONGER, HIGH SPEED STEEL EDGE WITH TITANIUM COATING KEEPS BLADES CUTTING AFTER OTHERS HAVE QUIT. SHATTER RESISTANT CONSTRUCTION ALLOWS BLADES TO BEND AND FLEX WITHOUT BREAKING. FITS ALL STANDARD UTILITY KNIVES. 100 CT DISPENSER PACK.

**STOCK NO. LEN20352**

**SUPERKNIFE**



THE ORIGINAL FOLDING UTILITY KNIFE, A CONVENIENT HYBRID OF A POCKET KNIFE AND A UTILITY KNIFE. ACCEPTS MOST STANDARD UTILITY KNIFE BLADES. COMES WITH ALL IN ONE TOOL FOR QUICK BLADE CHANGES. COMES WITH STANDARD AND RUBBERIZED HANDLES.

<b>STOCK NO.</b>	COLOR
<b>SN901</b>	SILVER
<b>SN902</b>	BLACK
<b>SN903</b>	BLUE
<b>SN904</b>	RED
<b>SN562</b>	BLACK - RUBBERIZED
<b>SN563</b>	BLUE - RUBBERIZED
<b>SN939</b>	ORANGE - RUBBERIZED
<b>SN940</b>	CAMO - RUBBERIZED

**SUPERKNIFE BLADE DISPENSER**

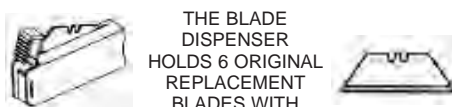

THE BLADE DISPENSER HOLDS 6 ORIGINAL REPLACEMENT BLADES WITH AGGRESSIVE DOUBLE GROUND EDGE AND .040" THICK BLADES.

**STOCK NO. SN918**

ONLY THE BILLIONAIRE AND HIS FRIEND REMAINED AFTER ALL THE GUESTS AT HIS WEEKEND RANCH PARTY SCURRIED OFF FOR THE AFTERNOON'S ENTERTAINMENT. THE HOST ANSWERED THE PHONE AND SLAMMED DOWN THE RECEIVER IN DISGUST. "I HAVE TO GO TO DALLAS, AND I'VE NO WAY TO GET THERE!" "SURE YOU DO," HIS FRIEND REASSURED HIM. "ISN'T THAT A CADILLAC CONVERTIBLE WITH THE KEYS IN IT?" "YES, BUT THAT'S MY WIFE'S CAR." "SO WHY CAN'T YOU USE IT?" "ARE YOU KIDDING? THE WINDSHIELD'S GROUND TO HER PRESCRIPTION."

**UTILITY KNIFE BLADES**



HEAVY-DUTY .025 THICK BLADES. UNIVERSAL TO FIT ALL STANDARD KNIVES.

5 PACK (CARDED) **STOCK NO. USB11212**      100 PACK (20-5'S) **STOCK NO. USB11211**

HEAVY-DUTY .035 THICK BLADES. UNIVERSAL TO FIT ALL STANDARD KNIVES.

5 PACK (CARDED) **STOCK NO. STW11931**

3 NOTCH H.D. BLADES (FIXED BLADE KNIVES) **STOCK NO. USB11217**

**HEAVY-DUTY BLADE DISPENSER**

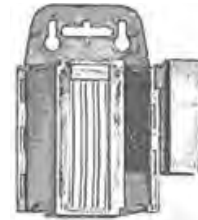

DISPENSER HOLDS 100 HEAVY-DUTY UTILITY BLADES. ONE BLADE DISPENSED AT A TIME. DESIGNED TO BE WALL HUNG OR FITS EASILY INTO A TOOL BOX. 100 BLADES INCLUDED.

**STOCK NO. HY42101**

**RAZOR BLADE SCRAPPERS**



REMOVES PAINT AND STICKERS FROM WINDOW GLASS. METAL CONSTRUCTION. RETRACTABLE BLADE WITH SAFE LOCKING PUSH BUTTON CONTROL (ONE BLADE INCLUDED).

**STOCK NO. HY13000**

**SINGLE-EDGE RAZOR BLADES**

USE IN RAZOR BLADE SCRAPPERS, RAZOR



KNIVES, WALLCOVERING KNIVES AND VINYL KNIVES. INDUSTRIAL-QUALITY STEEL. OILED TO PREVENT RUSTING.

**STOCK NO. USB11102 (5 PK).**  
**STOCK NO. USB11101 (100 PK).**

**CARTON CUTTER**

USE TO CUT CORRUGATED CARDBOARD, PAPER,



WALLCOVERING AND GENERAL PURPOSE. METAL FRAME CONSTRUCTION HOLDS SINGLE-EDGE RAZOR BLADE. BLADE RETRACTS FOR SAFETY (ONE BLADE INCLUDED).

**STOCK NO. USB11428**

**UTILITY RAZOR KNIVES, SCRAPPERS AND SPECIAL PURPOSE KNIVES**

**SNAP-OFF BLADE UTILITY KNIFE**



USED TO CUT DRYWALL, CARPETING, WALLCOVERING, ETC. 8 SHARP POINTS PER BLADE. RETRACTABLE BLADE WITH SAFE-LOCKING THUMB SCREW CONTROL. BLADE BREAKER INCLUDED. SIZE OF BLADE IS 18MM. 1 BLADE INCLUDED.

STOCK NO. HY42030 (KNIFE)  
STOCK NO. HY42330 (5 PK. OF BLADES)

**SNAP-OFF BLADE UTILITY KNIFE**

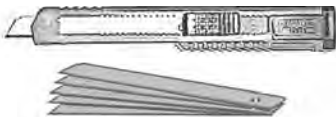

USED TO CUT WALLCOVERING, CARDBOARD, PAPER, FOIL, ETC. 12 SHARP POINTS PER BLADE. RETRACTABLE BLADE WITH SAFE-LOCKING PUSH BUTTON CONTROL. POCKET CLIP WITH BUILT-IN BLADE BREAKER. SIZE OF BLADE IS 8MM. 1 BLADE INCLUDED.

STOCK NO. HY42035 (KNIFE)  
STOCK NO. HY42345 (5 PK. OF BLADES)

**LINOLEUM KNIFE**



USED TO CUT FLOOR COVERING AND DRYWALL MATERIAL. HIGH CARBON CUTLERY STEEL BLADE; HARDENED, TEMPERED AND HONED. BURNT HARDWOOD HANDLE. 2-1/2" SHORT POINT.

STOCK NO. HY20160

**SLOYD KNIFE**



USED FOR WOOD CARVING AND GENERAL PURPOSE. EXTRA SHARP HIGH CARBON STEEL BLADE. HARDWOOD HANDLE. 2-5/8" BLADE.

STOCK NO. HY40060

BY INFLECTION YOU CAN SAY MUCH MORE THAN YOUR WORDS DO.

--MALCOLM S. FORBES

**SLITTING POCKET KNIFE**



EXTRA-LARGE CURVED SHEEP FOOT SLITTING BLADE (2-5/8" LONG). IDEAL FOR HEAVY-DUTY LINE WORK. BLADE LOCKS OPEN. STANDARD CARBON STEEL BLADE. 4" LENGTH (CLOSED).

STOCK NO. VA15504

**HEAVY-DUTY MILL KNIFE**



HARDWOOD HANDLE WITH CUTLERY COMPRESSION RIVETS. 14 GAUGE 4 X 1-1/4 BLADE.

STOCK NO. HY61770

**2-BLADE POCKET KNIFE**



BOTH STANDARD SPEARPOINT BLADE AND SCREWDRIVER-TIP BLADE ARE 2-1/2" LONG. SCREWDRIVER BLADE LOCKS OPEN. STANDARD CARBON STEEL

BLADES. 3-3/4" LENGTH (CLOSED).

STOCK NO. VA15502

**QUALITY PRODUCTS, FAIR AND COMPETITIVE PRICES, AND EXCELLENT SERVICE IS OUR REPUTATION**



**WE STOCK OVER 30,000 INVENTORY ITEMS**

**WE ARE CONSTANTLY ADDING TO OUR PRODUCT LINES TO SUIT YOUR APPLICATIONS. IF YOU DON'T SEE IT IN OUR CATALOG, CALL US. WE WILL DO EVERYTHING TO ACCOMMODATE YOUR NEEDS.**

LOST ON BACK ROADS IN VERMONT, A TOURIST COLLIDED WITH A LOCAL MAN AT AN INTERSECTION. HE AND THE LOCAL GOT OUT TO EXAMINE THEIR BENT FENDERS. "WELL, DON'T LOOK LIKE MUCH," OBSERVED THE LOCAL. "WHY'N'T WE JUST TAKE A LITTLE PULL TO STEADY OUR NERVES." HE GRABBED A JUG FROM HIS BATTERED PICKUP, REMOVED THE STOPPER AND HANDED IT TO THE TOURIST. AFTER TAKING A GOOD SLUG, THE TOURIST HANDED THE JUG BACK TO THE LOCAL, WHO BANGED IN THE STOPPER AND SET THE JUG BACK IN HIS TRUCK. "AREN'T YOU GOING TO HAVE SOME?" ASKED THE TOURIST. THE LOCAL SHOOK HIS HEAD. "NOT TILL AFTER THE TROOPER COMES."

**PUTTY AND SPECIAL PURPOSE KNIVES**

**PUTTY KNIVES**

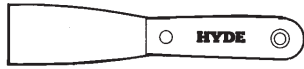

STOCK NO.	DESCRIPTION
HY02050	1-1/4 STIFF
HY02000	1-1/4 FLEX
HY02150	1-1/2 STIFF
HY02100	1-1/2 FLEX
HY02310	2" STIFF
HY02250	2" FLEX

**BENT PUTTY KNIFE**

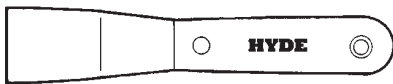

STOCK NO.	DESCRIPTION
HY02070	1-1/4 STIFF

**SCRAPERS**

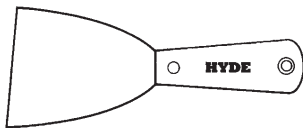

STOCK NO.	DESCRIPTION
HY02400	3" STIFF
HY02350	3" FLEX
HY02600	4" STIFF
HY02550	4" FLEX

**HEAVY-DUTY LONG HANDLE SCRAPER**



3" STIFF BLADE. DESIGNED FOR USE WITH PAINT REMOVERS. HIGH CARBON STEEL BLADE SECURELY ATTACHED TO 8" LONG POLYPROPYLENE HANDLE.

STOCK NO. HY12050

**HEAVY-DUTY BENT BLADE SCRAPER**

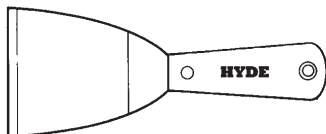

A RUGGED 3" WIDE STIFF STEEL BLADE BENT AT A 20 DEGREE ANGLE FOR EASY PAINT REMOVAL. SECURELY FASTENED TO POLYPROPYLENE HANDLE. TOOL MEASURES 9" OVERALL.

STOCK NO. HY12000

**HOMEOWNER PUTTY KNIFE**



RUGGED AND BUDGET PRICED FOR THOSE WHO WANT LOW COST AND DURABILITY. LARGE HOLE IN HANDLE TO HANG TOOL.

STOCK NO. HY04150 (1-1/2" STIFF)  
STOCK NO. HY04100 (1-1/2" FLEX)

**PUTTY CHISEL**



PROFESSIONAL QUALITY. ROSEWOOD HANDLE IS SECURELY RIVETED TO FULL TANG STEEL BLADE. HANDLES RESISTANT TO COMMON PAINT THINNERS. HIGH CARBON STEEL BLADE IS HARDENED, TEMPERED, PRECISION GROUND AND MIRROR FINISHED.

STOCK NO. HY07200 (1-1/4" STIFF)

**BRICK AND POINTING TROWELS**

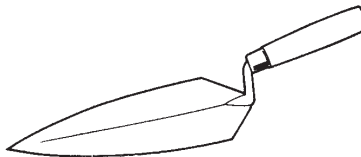

HARDENED, TEMPERED STEEL BLADES. FORGED SHANKS. HARDWOOD HANDLES WITH METAL FERRULE.

STOCK NO. HY18100 (5-1/2" POINT TROWEL)  
STOCK NO. HY18090 (10" BRICK TROWEL)

**CEMENT TROWELS**

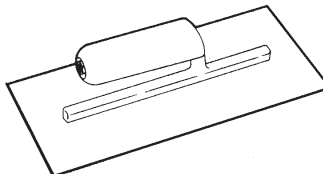

FOR CEMENT, DRYWALL AND PLASTER FINISHING. PROFESSIONAL TOOLS. HIGHEST GRADE FLEXIBLE SPRING STEEL BLADES; TEMPERED, GROUND AND POLISHED. ALUMINUM ALLOY BLADE MOUNTING FASTENED WITH 10 HARD STEEL RIVETS. SMOOTHLY TURNED WOOD HANDLES.

STOCK NO. HY18000 (STANDARD, 14" x 4" FLAT BLADE).

**MARGIN TROWELS**

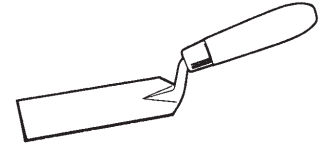

FOR PATCHING AND CLEANING OTHER TOOLS. HIGH QUALITY TEMPERED STEEL. TAPER GROUND FOR PROPER FLEXIBILITY. HARDWOOD HANDLES WITH METAL FERRULE.

STOCK NO. HY18050 (1-1/2" BLADE)  
STOCK NO. HY18060 (2" BLADE)

**THIS VALUABLE CATALOG  
IS YOUR GUIDE  
TO EFFICIENT BUYING**

**THIS IS A COMPREHENSIVE  
CATALOG OF OUR MAJOR LINES AND  
SERVICES, BUT IT DOES NOT SHOW ALL  
AVAILABLE PRODUCT LINES.  
IF THERE IS SOMETHING YOU NEED THAT IS  
NOT SHOWN, WE EITHER CARRY  
IT OR CAN GET IT. PLEASE CALL FOR  
INFORMATION OR  
WITH YOUR SUGGESTIONS.**



**SHEARS AND SCISSORS**

**ELECTRICIAN SCISSORS**



HOT-FORGED STEEL. CHROME OVER NICKEL. THIS ITEM OFFERS DOUBLE PROTECTION AGAINST STAINS AND RUST. SCRAPER/FILE ON BACK OF BLADE. WITH STRIPPING NOTCHES FOR 19 AND 23 GAUGE WIRES. 5-1/4" FULL LENGTH. 1-7/8" LENGTH OF CUT.

**STOCK NO. HERI100CS**

**LIGHTWEIGHT TRIMMERS**



PARTIAL SERRATION. RUST RESISTANT STAINLESS STEEL. WIDELY USED IN AUTO PLANTS FOR RUBBER FLASHING, UPHOLSTERY AND HEAD LINERS. 6-3/8" FULL LENGTH. 1-5/8" LENGTH OF CUT. PLASTIC CONTOURED HANDLES.

**STOCK NO. HERI545**

**STRAIGHT TRIMMERS**



HOT-FORGED HIGH CARBON STEEL. CHROME OVER NICKEL.

8" FULL LENGTH, 3" LENGTH OF CUT  
**STOCK NO. HERI107**

8" FULL LENGTH, 3-1/2" LENGTH OF CUT  
**STOCK NO. HERI108**

**BENT TRIMMERS**



HOT-FORGED HIGH CARBON STEEL. CHROME OVER NICKEL. DESIGNED WITH SOFT BLUE, REMOVABLE FINGER INSERTS.

7" FULL LENGTH, 3" LENGTH OF CUT  
**STOCK NO. HERI207**

10" FULL LENGTH, 4-3/4" LENGTH OF CUT  
**STOCK NO. HERI210**

**MULTI-PURPOSE SHEARS**



HEAVY-DUTY. HIGH LEVERAGE. HOT-FORGED ALLOY STEEL. CHROME OVER NICKEL. ADJUSTABLE.

8" FULL LENGTH, 2" LENGTH OF CUT  
**STOCK NO. HERI775**

8" FULL LENGTH, 2" LENGTH OF CUT  
**STOCK NO. HERI775S (ONE BLADE SERRATED)**

8" FULL LENGTH, 2-3/4" LENGTH OF CUT  
**STOCK NO. HERI717**

**LIGHTWEIGHT SHEARS**



RUST RESISTANT STAINLESS STEEL. LIGHTWEIGHT. COMFORT-FIT NYLON HANDLES. CONTOURED THUMB HOLE FOR FIRM CONTROL.

8-1/4" FULL LENGTH, 3-1/4" LENGTH OF CUT  
**STOCK NO. HERI7210**

9-1/2" FULL LENGTH, 3-3/4" LENGTH OF CUT.  
**STOCK NO. HERI7240**

WE STOCK  
OVER 30,000  
INVENTORY ITEMS

WE ARE CONSTANTLY  
ADDING TO OUR  
PRODUCT LINES  
TO SUIT YOUR  
APPLICATIONS.  
IF YOU DON'T SEE IT  
IN OUR CATALOG,  
CALL US.  
WE WILL DO EVERYTHING  
TO ACCOMMODATE  
YOUR NEEDS.

**LIGHT METAL SHEARS**



CHROME OVER NICKEL. EXTREME HI-LEVERAGE. POWERFUL CUTTING ACTION. EASY TO CONTROL FOR ACCURATE CUTTING. EXCELLENT FOR CUTTING LIGHT METALS, RUBBER, AND HEAVY FABRICS.

7" FULL LENGTH, 1-3/4" LENGTH OF CUT  
**STOCK NO. HERI716**

**ADDITIONAL ITEMS AVAILABLE UPON REQUEST**

**SERVICE  
YOU CAN  
DEPEND ON**

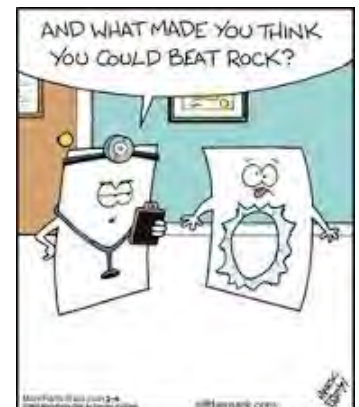



**GENERAL®**

**PUNCHES AND MARKING TOOLS**

**GENERAL®**

**DRIVE PIN PUNCH SET**



TOOL STEEL PUNCHES UNIFORMLY HEAT-TREATED, GROUND AND POLISHED. FINGER-GRIP KNURLED BODY. ENDS GROUND SQUARE. 4" LONG OVERALL. VINYL CASE. ONE SIZE EACH PER SET: 1/16, 3/32, 1/8, 5/32, 3/16, 7/32, 1/4, 5/16.

STOCK NO. GENSPC75

**EXTRA LONG PIN PUNCH SET**



8" LONG TO PERMIT REACHING HARD-TO-GET-AT PLACES. TOOL STEEL, HARDENED AND TEMPERED; CENTERLESS GROUND. KNURLED BODY IS 4-1/2" LONG, POINTS ARE 3-1/2" LONG AND GROUND FLAT ON ENDS. VINYL CASE. ONE SIZE EACH PER SET: 1/8, 3/16, 1/4, 5/16, 3/8.

STOCK NO. GENSPC76

**AUTOMATIC CENTER PUNCHES BALL BEARING**



LIGHTWEIGHT ALUMINUM BODY, ALLOY STEEL PARTS FOR LONG WEAR. ADJUSTABLE FOR LIGHT OR HEAVY STROKES. HAS SMOOTH, UNIFORM PRESSURE DESIRABLE WHERE FREQUENT OR REPETITIVE PUNCHING OR RIVETING IS USED. PRESSURE UNIFORM ALSO WHEN USED WITH INSPECTION SYMBOLS, EYELET OR CONNECTOR RIVETING, ETC. 5" LENGTH; 5/8" DIAMETER. POINT CAN BE SHARPENED FOR FURTHER USE.

STOCK NO. GEN77

**5 PIECE CENTER PUNCH SET**



ROUND SHANK, KNURLED GRIP. WILL NOT ROLL. TOOL HARDENED AND TEMPERED FULL LENGTH. EACH PUNCH STAMPED WITH SIZE. SET OF FIVE PUNCHES IN A VINYL CASE.

DIA. AT TOP OF TAPER	LENGTH	BODY DIA.
1/16	3-1/8	1/4
5/64	4"	5/16
3/32	4"	5/16
9/64	4"	3/8
5/32	4"	7/16

STOCK NO. GENSPC74

**SCRATCH AWL**



FINEST QUALITY. FULL-LENGTH ALLOY STEEL

BLADE RUNS THROUGH HARDWOOD FLUTED HANDLE AND IS SECURELY FASTENED TO BOTH THE PLATED STEEL FERRULE AND CAP. 3-3/4" BLADE, 6-1/2" LONG OVERALL.

STOCK NO. GEN818

**AWL**



THE TOOL WITH 1,000 USES. SHANK IS HOT-FORGED AND TAPERED TO A SHARP POINT. TOUGH AND DURABLE PLASTIC HANDLE. 8" OVERALL LENGTH.

STOCK NO. MAY31013

**TUNGSTEN CARBIDE POINT SCRIBER**



FOR SCRIBING, MARKING OR ENGRAVING ON HARD STEEL, GLASS, PLASTICS, CERAMIC, JEWELRY, ETC. SCREW CHUCK PERMITS REVERSING POINT WHEN NOT IN USE. 6" LONG. WITH POCKET CLIP.

STOCK NO. GEN88  
REPLACEMENT POINT GEN88P

**MAGNETIC TUNGSTEN CARBIDE SCRIBER**



TUNGSTEN CARBIDE TIP; ALNICO PERMANENT MAGNET ON OTHER END. POINT REVERSES FOR SAFETY.

STOCK NO. GEN88CM  
REPLACEMENT POINT GEN88P

**CIRCLE CUTTERS**



HEAVY DUTY. 1/2" ROUND SHANK FOR DRILL PRESS USE. COMPLETE WITH 1/4" HIGH SPEED TOOL BIT AND 1/4" DRILL. FOR CUTTING STEEL, OTHER METALS, WOOD, PLASTICS, ETC. HEX WRENCH INCLUDED. RANGE 1-3/4" TO 8"

STOCK NO. GEN55  
REPLACEMENT H.S. CUTTER BIT GEN55BLADE

**PRECISION TRAMMEL POINTS**



FOR MEASURING OR MARKING DISTANCES TOO GREAT FOR ORDINARY DIVIDERS. DIE CAST BODY WITH 3" NEEDLE POINT LEGS. COMPLETE WITH PENCIL HOLDER TO REPLACE LEG WHEN SO DESIRED. WITH FINE ADJUSTING SCREW.

STOCK NO. GEN520 (PER SET OF TWO)

**ADJUSTABLE TRAMMEL POINTS**



FOR ACCURATELY MEASURING OR MARKING DISTANCES GREATER THAN THE RANGE OF ORDINARY DIVIDERS. USE FOR LOFTING LAYOUTS, TEMPLATE MARKING, ETC. THE 6" OFF-CENTER POINTS CAN BE REPLACED WITH PENCILS, BALL PENS, CRAYONS, OR SOAPSTONE STICKS.

CLAMP OPENING WILL TAKE A BEAM 3/4" TO 1-3/8" THICK AND ANY WIDTH OR LENGTH.

STOCK NO. GEN523 (PER SET OF TWO)

**EDGE FINDERS**



FOR QUICKLY LOCATING WORK EDGES. A MODERATE PRICED TIMESAVING POSITIONING TOOL FOR JIG BORERS, MILLING AND OTHER MACHINES. PRECISION GROUND. DOUBLE END. 1/2" SHANK. .200" AND .500" SIZE.

STOCK NO. GEN262

**BRASS PLUMB BOBS**



MACHINED OF SOLID BRASS. FULLY POLISHED AND LACQUERED. REMOVABLE SELF-CENTERING CORD CAP FOR EASY CORD REPLACEMENT. REPLACEABLE HARDENED STEEL POINT.

STOCK NO.	WEIGHT	LENGTH	DIA.
GEN80010	10 OZ.	4-3/4	1-5/16
GEN80012	12 OZ.	5"	1-3/8
GEN80016	16 OZ.	5-3/4	1-1/2
80024	24 OZ.	6-1/2	1-11/16
80032	32 OZ.	7-1/4	1-7/8

REPLACEMENT PART GEN800NP (NEW STYLE POINT 10-32 THREAD).

**HEXAGON STEEL PLUMB BOBS**



MADE OF COLD DRAWN STEEL, NICKEL PLATED. REMOVABLE CORD CAP.

STOCK NO.	WEIGHT	LENGTH	WIDTH
GEN7908	8 OZ.	4"	7/8

ADDITIONAL ITEMS AVAILABLE UPON REQUEST

**GENERAL®**

**PRECISION AND MACHINISTS TOOLS**

**GENERAL®**

**READING GLASSES**



MAGNIFIES SMALL OR FINE PRINT FOR EASY READING. LENSES ARE GROUND AND POLISHED OPTICAL GLASS. WITH METAL RIMS AND RIBBED PLASTIC HANDLES.

STOCK NO.	DIA.	POWER
-	2"	1.4
<b>GEN541</b>	2-1/2"	1.4
<b>GEN542</b>	3"	1.4
<b>GEN543</b>	3-1/2"	1.2
-	4"	1.2
-	4-1/2"	1.2

**POWER MAGNIFIER WITH LIGHT**



4 POWER MAGNIFIER FITS IN POCKET. PLASTIC BODY AND LENS. REPLACEABLE BULB. BATTERIES INCLUDED.

**STOCK NO. GEN553**

**STAIR GAGE SET**



SOLID BRASS STAIR GAGE ASSURES FAST AND UNIFORM LAYOUT IN REPETITIVE WORK, INCLUDING ANGLE CUTS ON RAFTERS AND STAIR STRINGERS. ATTACHES EASILY TO ALL METAL RAFTER SQUARES.

**STOCK NO. GEN803**

**TELESCOPING MAGNETIC PICKUP TOOL**



STRONG PERMANENT ALNICO MAGNET IN NICKEL PLATED TELESCOPING HOLDER WITH POCKET CLIP. HOLDER EXTENDS FROM 6" TO 24". USED FOR RETRIEVING SMALL PARTS AND REMOVING STEEL DUST AND CHIPS FROM DRILLED HOLES.

**STOCK NO. GEN383X**

**POT MAGNETS**



UNIQUE COMBINATION OF STRONG MAGNET WITH INSULATING RING GIVES SUPERIOR HOLDING POWER. 1/4-20 THREADED HOLE FOR ATTACHING TO FIXTURES AND MACHINES.

<b>STOCK NO. GEN374A</b>	(5/8" x 11/16)
<b>STOCK NO. GEN374B</b>	(3/4" x 13/16)
<b>STOCK NO. GEN374C</b>	(1" x 1-1/16)
<b>STOCK NO. GEN374D</b>	(1-3/16" x 1-3/8)

**SINGLE END PIN VISE**



FOR HOLDING SMALL RODS, WIRE, DRILLS, TAPS, AND OTHER SMALL TOOLS. NICKEL PLATED BODY IS HOLLOW TO PERMIT HOLDING OF LONG RODS OF WIRE. TOOL STEEL COLLETS ARE HARDENED AND GRIP FIRMLY WHEN SCREW CHUCK IS TIGHTENED. RANGE 0 TO .055 (0 TO 1.40MM).

**STOCK NO. GEN94A**

**STAINLESS STEEL REFERENCE TABLE**



A HANDY REFERENCE TABLE FOR TOOLMAKERS, MACHINISTS, MECHANICS, AND HOME CRAFTSMEN. FRONT HAS TAP DRILL SIZES FOR 75% RECOMMENDED DEPTH OF THREAD ON MACHINE SCREW SIZES. BACK HAS DECIMAL EQUIVALENTS TABLE IN 64THS FROM 1/64 TO 63/64 WITH A QUICK READING 6" RULE.

**STOCK NO. GEN715**

**APPRENTICE VERNIER CALIPERS**

AMERICAN MADE. A MODERATELY PRICED SLIDE



CALIPER WITH ROLLER ADJUSTMENT. HAS BOTH INSIDE AND OUTSIDE JAWS AND FULL-LENGTH DEPTH GAGE. 5" CAPACITY, IN 16THS AND 32NDS WITH A VERNIER READING OF 1/128TH.

**STOCK NO. GEN721**

**APPRENTICE POCKET CALIPERS**



STAINLESS STEEL. A HANDY POCKET SLIDE CALIPER WITH INSIDE AND OUTSIDE READING IN 16THS AND 32NDS. DECIMAL EQUIVALENTS ON BACK. 5" RULE.

**STOCK NO. GEN729**

**3" APPRENTICE POCKET CALIPER**



STAINLESS STEEL CALIPER, WITH INSIDE/ OUTSIDE READING IN METRIC AND INCHES. 3" CAPACITY. DECIMAL EQUIVALENTS.

**STOCK NO. GEN132ME**

**ADDITIONAL ITEMS AVAILABLE UPON REQUEST**

**STEEL PROTRACTORS**



STAINLESS STEEL. GRADUATED FROM 0 TO 180 DEGREES IN OPPOSITE DIRECTIONS. 3-3/8 X 2 HEAD. 6" ADJUSTABLE ARM LOCKS WITH KNURLED THUMB NUT.

**STOCK NO. GEN17** (SQUARE HEAD)

**STOCK NO. GEN18** (ROUND HEAD)

**SLIDING T-BEVEL**



SOLID ROSEWOOD HANDLE WITH BRASS TRIM AND LOCKING WING NUT. 8" BLADE. PREFERRED BY CARPENTERS, CABINETMAKERS AND BUILDERS.

**STOCK NO. GEN829**

**DRILL GRINDING ATTACHMENT**



SHARPENS DRILL BITS TO FACTORY ACCURACY. EXTENDS BIT LIFE. ANGLE ADJUSTMENTS LOCK IN TO GRIND BITS FOR MORE ACCURATE DRILLING IN A VARIETY OF MATERIALS. ADJUSTS AUTOMATICALLY. FOR USE WITH ANSI, OSHA AND UL APPROVED STANDARD ELECTRIC BENCH GRINDERS OR

SURFACE GRINDERS. CAPACITY: 1/8" - 3/4" DRILLS, NUMBER DRILLS 30 - 1, LETTER DRILLS A - Z, MILLIMETER DRILLS 3.0 - 19.0.

**STOCK NO. GEN825**

DID YOU HEAR ABOUT THE SCIENTIST WHO CROSSED A CARRIER PIGEON WITH A WOODPECKER?

HE GOT A BIRD THAT NOT ONLY DELIVERS MESSAGES TO THEIR DESTINATION BUT KNOCKS ON THE DOOR WHEN IT GETS THERE.

**GENERAL®**

PRECISION TOOLS AND STEEL RULES

**GENERAL®**

**MULTI-USE RULE AND GAGE**



MADE OF STAINLESS STEEL. HAS A 4" RULE GRADUATED IN 32NDS AND MILLIMETERS. USED AS A DRILL POINT GAGE, A SQUARE, BEVEL PROTRACTOR AND CENTER FINDER. ALSO HAS A TAP AND DRILL TABLE.

STOCK NO. GEN16ME

**STEEL RULES  
300 SERIES**



STAINLESS STEEL. WITH DEPTH GAGE POCKET CLIP. 32NDS AND 64THS ON ONE SIDE, DECIMAL EQUIVALENTS ON BACK. 6" LONG, 15/32" WIDE. FLEXIBLE.

STOCK NO. GEN300



STAINLESS STEEL. WITH DEPTH GAGE POCKET CLIP. ONE SIDE GRADUATED IN 64THS AND 32NDS. 6" LONG, 1/4" WIDE.

STOCK NO. GEN301



SEMI-FLEXIBLE STAINLESS STEEL. ONE SIDE GRADUATED IN MILLIMETERS AND 16THS. 6" LONG, 15/32" WIDE.

STOCK NO. GEN305ME

**PRECISION STAINLESS  
STEEL RULES**



FLEXIBLE STAINLESS STEEL. GRADUATED IN 10THS AND 100THS ON ONE SIDE AND IN QUICK-READING 32NDS AND 64THS ON OTHER SIDE. (GRAD NO. 5). 6" LONG, 15/32" WIDE.

STOCK NO. GEN616

STOCK NO. GENCF616



STIFF STAINLESS STEEL. GRADUATED IN QUICK-READING 32NDS AND 64THS ON ONE SIDE AND IN 8THS AND 16THS ON OTHER SIDE (GRAD NO. 4).

STOCK NO. GEN676 (6" LONG, 3/4" WIDE).

STOCK NO. GEN1276 (12" LONG, 1" WIDE).

**DRILL STOP SET**



FOR USE ON TWIST OR BRAD POINT DRILLS TO PREVENT EXCESSIVE DRILL PENETRATION. POSITIVE DEPTH CONTROL ASSURES EXACT HOLE DEPTHS FOR MULTIPLE DRILLING JOBS. BLACK OXIDE FINISH ON COLD ROLLED STEEL. SIZES: 3/16", 1/4", 5/16", 3/8", 7/16", 1/2". HEX WRENCH INCLUDED.

STOCK NO. GENS838

**CARPENTER'S COMBINATION  
SQUARE**



SPECIALLY DESIGNED FOR CARPENTERS AND THE WOODWORKING TRADES. MACHINED AND ENAMELED CAST IRON HEAD HAS PRECISION LEVEL AND SCRIBER FOR PRODUCING RIGHT AND 45° ANGLES. SATIN CHROME FINISH 12" x 1" STEEL BLADE IS GRADUATED ON BOTH SIDES. SELF-ALIGNING DRAWBOLT.

STOCK NO. GEN812

**UTILITY COMBINATION SQUARE**



ECONOMY-VERSION OF THE CARPENTER'S COMBINATION SQUARE. STEEL BLADE IS 12" x 1" AND GRADUATED IN 8THS, 16THS AND 32NDS. HEAVY ZINC-CAST HEAD WITH LEVEL AND SCRIBER. SELF-ALIGNING DRAWBOLT.

STOCK NO. EM230

**MAGNETIC PROTRACTOR LEVEL**



FUNCTIONS AS LEVEL, PROTRACTOR, SQUARE AND PITCH GAGE. MEASURES ANGLES IN FULL 360° RANGE. ACCURATELY TRANSFERS ANGLES AND MEASURES PITCH ANGLES. INSTANTLY ADJUSTABLE.

STOCK NO. EM361

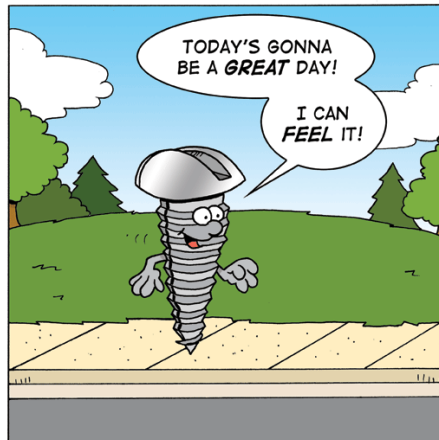

SPUDCOMICS.COM © 2010 LONNIE EASTERLING

BEFORE HE GOT SCREWED

THIS SPACE RESERVED FOR  
FUTURE PRECISION TOOLS



**LYON INDUSTRIES**



**BOXED STEEL SHIM STOCK**



MILD STEEL - LOW CARBON. C1010 NO. 1 TEMPER.

6" WIDE x 100" LONG ROLLS

STOCK NO. THICKNESS

LY001	.001
LY002	.002
LY003	.003
LY004	.004
LY005	.005
LY006	.006
LY007	.007
LY008	.008
LY009	.009
LY010	.010
LY011	.015
LY012	.020
LY013	.025
LY014	.031

12" WIDE x 120" LONG ROLLS

STOCK NO. THICKNESS

LY023	.002
LY024	.003
LY025	.005
LY026	.007
LY027	.009
LY028	.010
LY029	.015
LY0291	.020
LY0292	.025
LY0295	.031

**12 PC. STEEL SHIM STOCK ASSORTMENT**

6" x 12"

ONE EACH: .001, .0015, .002, .003, .004, .005, .006, .007, .008, .010, .012, .015

STOCK NO. LY030

**BOXED BRASS SHIM STOCK**

6" WIDE x 100" LONG ROLLS



STOCK NO. THICKNESS

LY015	.001
LY016	.002
LY017	.003
LY018	.004
LY019	.005
LY020	.006
LY021	.007
LY022	.010
LY0221	.015

STAINLESS STEEL SHIM STOCK AVAILABLE UPON REQUEST

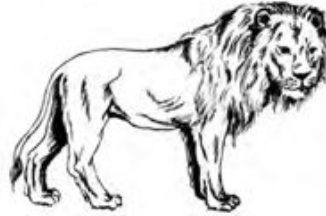

**STAINLESS STEEL LOCKWIRE**



STOCK NO. LYLW41 (.041 DIAMETER)

**MUSIC WIRE**



MADE OF HIGH CARBON STEEL ALLOY THAT COMBINES EXTREMELY HIGH TENSILE STRENGTH WITH HIGH FATIGUE RESISTANCE. ITS MANY APPLICATIONS INCLUDE SPRINGS, WIRE FORMS, CONTROL LINKAGES, ARMATURE BINDING AND CERAMIC CUTTING. 1 LB. EACH.

STOCK NO.	WIRE DIA.	FT./LB.
MW010	.010	3749
MW014	.014	1913
MW016	.016	1464
MW018	.018	1156
MW020	.020	937
MW022	.022	774
MW024	.024	651
MW026	.026	575
MW029	.029	446
MW031	.031	400
MW033	.033	344
MW035	.035	306
MW041	.041	223
MW045	.045	190
MW049	.049	156
MW055	.055	123
MW059	.059	110
MW063	.063	95
MW071	.071	78
MW075	.075	71
MW080	.080	58

ADDITIONAL MUSIC WIRE AVAILABLE UPON REQUEST

**FEELER GAUGES**



CLOSE TOLERANCE. 1095 TEMPERED SPRING STEEL. SMOOTH ROUND EDGES. 1/2" x 12".

STOCK NO. THICKNESS

LY032	.001
LY033	.0015
LY034	.002
LY035	.0025
LY036	.003
LY037	.004
LY0375	.005
LY038	.006
LY039	.007
LY040	.008
LY041	.009
LY042	.010
LY043	.011
LY044	.012
LY045	.013
LY046	.014
LY047	.015
LY048	.016
LY049	.017
LY050	.018
LY051	.019
LY052	.020
LY053	.021
LY054	.022
LY055	.023
LY056	.024
LY057	.025
LY058	.026
LY059	.027
LY060	.028
LY061	.029
LY062	.030
LY0625	.031
LY063	.032
LY0635	.034
LY064	.035

ADDITIONAL FEELER GAUGES AVAILABLE UPON REQUEST

**CUSTOMER SATISFACTION IS THE KEY TO OUR SUCCESS**



**PRECISION MEASURING TOOLS**



**FEELER GAUGES**

**25 BLADE - 12" EXTRA LONG**



SIZES: .0015, .002 THROUGH .021, .025, .027, .030 AND .040. 12" x 1/2" EACH.

**STOCK NO. KA12025**

**13 BLADE - PRECISION FEELER GAUGE**

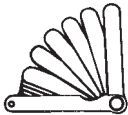

HARDENED AND TEMPERED FEELER GAUGE STOCK. STRAIGHT BLADE. SIZES: .0015, .002, .003, .004, .006, .008, .010, .020, .030, .040, .075, .100, .200 INCH.

**STOCK NO. ST25003700**

**32 BLADE MASTER FEELER GAUGE**



RANGE FROM .0015 TO .035 AND METRIC SIZES FROM .038mm TO .889mm. ALSO INCLUDES BRASS BLADE FOR ELECTRONIC IGNITIONS.

**STOCK NO. RIM0552**

**PRECISION THICKNESS GAUGE**



IDEAL FOR MECHANICS. SIZES: .0015 TO .035 WITH METRIC EQUIVALENTS. 25 BLADE SET. 1/2" x 3-1/4" EACH.

**STOCK NO. RIM0026**

**20 BLADE FEELER GAUGE**



SIZES: .001, .0015, .002 THROUGH .010, .012, .014, .015, .016, .018, .020, .022, .024, .025. METRIC RANGE: .025MM - .635MM. 6" x 1/2" EACH. PACKED IN POUCH.

**STOCK NO. KA76020**

**SHEET METAL and WIRE GAUGES**

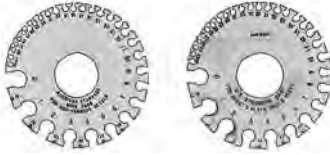

**AMERICAN STANDARD WIRE GAUGE**

ACCEPTED STANDARD FOR GAUGING SHEETS, PLATES AND WIRE MADE OF NON-FERROUS METALS SUCH AS COPPER, BRASS, ALUMINUM, ETC. SIZE RANGE FROM 0-36.  
**STOCK NO. GEN20**

**U.S. STANDARD SHEET METAL GAUGE**

RECOGNIZED COMMERCIAL STANDARD FOR UNCOATED SHEET, PLATE IRON AND STEEL. SIZE RANGE FROM 0-36.  
**STOCK NO. GEN21**

**THREAD GAUGE**



30 GAUGE THREAD GAUGE QUICKLY FINDS THE NUMBER OF THREADS PER INCH FROM 4 TPI - 42 TPI.  
**STOCK NO. RIM5400**

20 BLADE THREAD GAUGE QUICKLY MEASURES THE GAP BETWEEN THREADS FROM .40MM - 6.00MM.  
**STOCK NO. RIM5401 (METRIC)**

**SCREW PITCH GAUGES**

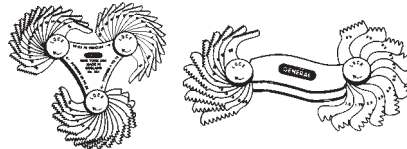

SCREW PITCH GAUGES DETERMINE THE PITCH OF VARIOUS THREADS. BY MATCHING THE TEETH WITH THE THREAD ON THE WORK, THE CORRECT PITCH CAN EASILY BE READ DIRECTLY FROM THE LEAF. INCLUDES V, AMERICAN NATIONAL, AND U.S. STANDARD 60 DEGREE THREADS.

**2 GROUP GAUGE (28 BLADES)**

- 1). 4, 4-1/2, 5, 6, 7, 8, 9, 10, 11, 11-1/2, 12, 13, 14, 16 INCH
- 2). 18, 20, 24, 27, 28, 32, 36, 40, 44, 48, 56, 64, 72, 80 INCH

**STOCK NO. ST25003300**

**USS/SAE METRIC FASTENER GAUGE**



EVERY SHOP SHOULD HAVE THIS. QUICKLY IDENTIFIES FRACTIONAL AND METRIC BOLT SIZES AND THREAD PITCHES. ALSO CAN BE USED TO IDENTIFY FRACTIONAL NUT SIZES AND METRIC/FRACTIONAL LENGTHS. FRACTIONAL SIZES #8-1", 32 TPI TO 10TPI, METRIC SIZES 6MM TO 22MM, .75 - 2.5 THREAD SIZE.

**STOCK NO. X23143**

**RADIUS GAUGE SET**



RADI OR FILLETS CAN BE CHECKED EASIER AND FASTER FOR MATCHING, LAYOUTS OR INSPECTION. GAUGES ARE CLEARLY MARKED. INCLUDES GAUGE HOLDER. EACH GAUGE HAS 5 MEASURING SURFACES FOR CONCAVE OR CONVEX RADI. ADDITIONAL FRACTIONAL OR DECIMAL SIZES AVAILABLE UPON REQUEST. 25 GAUGES. RANGE: 1/64 - 17/64 X 64THS 9/32 - 1/2 BY 32NDS.

**STOCK NO. ST96000200**

**PEE DEE THREAD MEASURING SET**



SET MEASURES U.S. 60 DEGREE THREADS FROM 3 TO 48 T.P.I., METRIC .5mm TO 6mm PITCH AND ACME 3 TO 16 T.P.I. ACCURATE TO .0003". 48 WIRES - 16 SIZES. SIZE AND MEASUREMENTS CHART. FURNISHED IN PLASTIC CASE.

**STOCK NO. ST96633200**

**DRILL GAUGES**

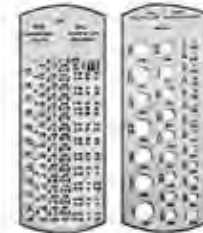

**NUMBER DRILL GAUGE**

**1-60 TWIST DRILL AND MACHINE SCREW TAP GAUGE:** TELLS AT A GLANCE THE CORRECT SIZE TAP DRILL FOR MACHINE SCREW TAP IN NATIONAL FINE (NF) OR NATIONAL COARSE (NC) THREAD SERIES. SHOWS THE CORRECT BODY SIZE DRILL TO USE. DECIMAL EQUIVALENTS.  
**STOCK NO. ST25001600**

**FRACTIONAL DRILL GAUGE**

**1/16 to 1/2 FRACTIONAL SIZE GAUGE:** HAS 29 MEASURING HOLES FOR DETERMINING TWIST DRILL SIZES IN 1/64 INCREMENTS. DECIMAL EQUIVALENTS.  
**STOCK NO. ST25001700**

**STOCK NO. HU9092 (ECONOMY)**

**LETTER DRILL GAUGE**

**A-Z ALPHABET DRILL GAUGE:** EACH HOLE IS MARKED BY LETTER SIZE AND ITS DECIMAL EQUIVALENTS FROM .234 INCH DIAMETER THROUGH .413 INCH DIAMETER.  
**STOCK NO. ST25001800**

# ST INDUSTRIES, INC.

## PRECISION MEASURING TOOLS

# ST INDUSTRIES, INC.

### QUICK NUT CALIPERS

POLISHED STEEL. ROUNDED EDGES AND TIPS. EASY ADJUSTMENT OVER ENTIRE RANGE. BALANCED LEGS. UNIFORM TENSION.

#### INSIDE SPRING CALIPER



STOCK NO.	SIZE
ST25008210	10"

#### OUTSIDE SPRING CALIPERS



STOCK NO.	SIZE
ST25008308	8"
ST25008310	10"
ST25008312	12"

### SOLID NUT CALIPERS & DIVIDERS



POLISHED STEEL. ROUNDED EDGES AND TIPS. EASY ADJUSTMENT OVER ENTIRE RANGE. BALANCED LEGS. UNIFORM TENSION.

STOCK NO.	SPRING DIVIDERS	SIZE
ST25005903		3"
25005904		4"
ST25005906		6"
ST25005908		8"
ST25005910		10"

CONTINUED NEXT COLUMN

### INSIDE SPRING CALIPERS



STOCK NO.	SIZE
ST25006104	4"
ST25006106	6"
ST25006110	10"

### OUTSIDE SPRING CALIPERS



STOCK NO.	SIZE
ST25006004	4"
ST25006006	6"

### DIAL INDICATORS



ACCURACY IN ACCORDANCE WITH AGD SPECIFICATIONS. ADJUSTABLE BEZEL AND TOLERANCE POINTERS. EASY READING WHITE DIAL FACE WITH BLACK GRADUATIONS. SHOCK PROOF MECHANISM. SUPPLIED WITH CENTER LUG BACK. ADDITIONAL STYLES AND DIAMETERS AVAILABLE UPON REQUEST.

STOCK NO.	DIA.	GRAD.	READING	RANGE
ST50112700	1-11/16	.001"	0-100	.250"
ST50113000	1-11/16	.0005"	0-10-0	.050"
ST50042300	2-1/4	.001"	0-100	1.000"
STC1530020*	2-1/4	.001"	0-100	2.000"
DTNB70AI921*	2-1/8	.001"	0-100	1.000"

\*ECONOMY

### UNIVERSAL MAGNETIC BASE HOLDERS



MAY BE USED WITH ANY TYPE DIAL INDICATOR. PERMANENT MAGNETIC BASE FEATURES AN ON/OFF SWITCH WITH A MAGNETIC PULL OF 150 LBS. 3/8 DIAMETER VERTICAL COLUMN. 2" x 2-1/2 x 2-1/4 BASE. 7" HIGH POST.

STOCK NO. STC1540000

ADDITIONAL ITEMS AVAILABLE UPON REQUEST

### UNIVERSAL DIAL INDICATOR TEST SET



COMPLETE PRECISION UNIT USED BY TOOL-MAKERS, MACHINISTS AND INSPECTORS. FAST, ACCURATE SETUPS AND SPEED WORK MEASUREMENTS IN LATHES, MILLING MACHINES, SHAPERS, ETC. SET INCLUDES: UNIVERSAL TEST INDICATOR (BACK PLUNGER, .200 RANGE, .001" GRAD., FULLY JEWELLED), UNIVERSAL CLAMP, TOOL POST HOLDER, 5/16 x 3" and 5/16 x 5" HOLDING RODS, "G" CLAMP, LEVER ATTACHMENT, DOMED, TAPERED & STANDARD ANVILS, FITTED CASE.

STOCK NO. ST50240000

### POCKET DIAL THICKNESS GAUGE



DESIGNED TO QUICKLY GAUGE THE THICKNESS OF PAPER, LEATHER, PLASTIC SHEETS, WIRE, SHEET METAL AND SEVERAL OTHER ITEMS. CONTINUOUS DIAL WITH REVOLUTION COUNTER. GROUND AND LAPPED CONTACTS. .5" RANGE. .001" GRADUATIONS. .39" THROAT DEPTH. 0-100 READING.

STOCK NO. ST64135301

**LET US KNOW  
WHAT WE CAN DO  
TO HELP SERVE YOU BETTER!**



**PRECISION MEASURING TOOLS**



**ECONOMY DIAL CALIPER**



CONVENIENT, ONE-REVOLUTION CALIPER. ONE-HANDED USE PERMITS OUTSIDE, INSIDE, DEPTH AND STEP MEASURING CAPABILITIES. STAINLESS STEEL. SHARP GRADUATIONS ON BEAM AND DIAL FACE. COVERED RACK. ADJUSTABLE BEZEL WITH LOCK. THUMB ROLL WITH LOCK. FITTED CASE. .001" GRADUATIONS. .100" RANGE/REV. 2-1/2" JAW LENGTH.

**STOCK NO. STC1495106** (6" RANGE)  
**STOCK NO. STC1495108** (8" RANGE)  
**STOCK NO. STC1495112** (12" RANGE)

**STARRETT 6" DIAL CALIPERS**

SHARP, CLEAR DIAL GRADUATIONS OF .001"-.100" IN ONE REVOLUTION. KNIFE EDGE CONTACTS FOR BOTH INSIDE AND OUTSIDE MEASUREMENTS. ONE HAND USE WITH THUMB-OPERATED, FINE ADJUSTMENT ROLL. DEPTH ROD ATTACHMENT AVAILABLE TO SET TOOL FOR ACCURATE DEPTH MEASUREMENTS.

**STOCK NO. LSSP64514**

**MANDREL BLADE MICROMETER**



INTERCHANGEABLE MANDRELS FOR AN EXTENDED RANGE OF MEASUREMENT. BLADES ARE .017" THICK. INCLUDES MANDRELS, CHECKING STANDARDS AND FITTED WOODEN CASE. CARBIDE SPINDLE AND ANVIL STANDARD. SPINDLE HARDENED TO RC 62-64 WITH LEAD ERROR HELD TO .00005".

**STOCK NO. ST07103012**

**SCREW THREAD MICROMETERS**



SCREW THREAD MICROMETER SPINDLE AND ANVIL ARE DESIGNED TO PERMIT MEASUREMENT OF SCREW THREADS ON PITCH DIA. FLOATING/ROTATING ANVIL. DECIMAL EQUIVALENTS STAMPED ON FRAME. LOCK NUT AND RATCHET STOP.

STOCK NO.	RANGE INCH	RANGE THREADS	GRAD. INCH
<b>ST08805304</b>	0-1	8-13	.001
<b>ST08806204</b>	1-2	8-13	.001

**FRICTION THIMBLE MICROMETERS**



180 SERIES MICROMETERS FEATURE FRICTION THIMBLE AND CONVENIENT LEVER LOCK. FORGED STEEL FRAME HAS REINFORCEMENT RIBBINGS. CARBIDE SPINDLE AND ANVIL FACES.

STOCK NO.	RANGE INCH	GRAD. INCH
<b>ST02018114</b>	0-1	.0001
<b>STC4753010*</b>	0-1	.0001
<b>ST02018214</b>	1-2	.0001
<b>ST02018314</b>	2-3	.0001
<b>ST02018414</b>	3-4	.0001

\*ECONOMY

**BLADE MICROMETERS**



THIS STYLE OF MICROMETER HAS A .017" THICK ANVIL AND SPINDLE CONTACTS TO ACHIEVE PRECISION MEASUREMENTS IN THE NARROWEST OF GROOVES. THE NON-ROTATING SPINDLE AND ANVIL ARE HARDENED, GROUND AND LAPPED. CASE AVAILABLE (NOT INCLUDED)

STOCK NO.	RANGE INCH	GRAD. INCH
07001002	0-1	.001
07002002	1-2	.001
<b>ST07003002</b>	2-3	.001

**DIGITAL MICROMETERS**



DIGITAL MICROMETERS OFFER SOME ADVANTAGES OVER CONVENTIONAL MODELS. THEY ALMOST ELIMINATE ERRORS IN GAGING. BLACK LINES AND NUMBERS ON BARREL AND HEAD PROVIDE EASY READING. FAST AND EASY ZERO ADJUSTMENT. INCLUDES FITTED CASE.

STOCK NO.	RANGE INCH	READING
<b>ST52300100</b>	0-1	.0001
<b>ST52300200</b>	1-2	.0001

**DEPTH MICROMETER**

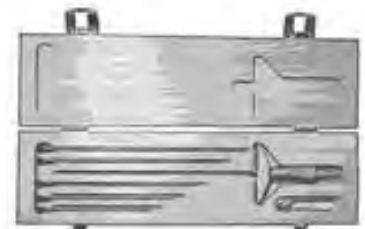

INTERCHANGEABLE RODS MEASURE HOLES, GROOVES, SHOULDERS, ETC. UP TO 10" IN DEPTH. RODS ARE EASILY INSERTED AND HELD BY KNURLED ROD CAP. ADJUSTING NUTS ON END OF ROD COMPENSATES FOR WEAR. ENDS OF RODS ARE HARDENED, PRECISION-GROUND AND LAPPED. INCLUDES FITTED WOODEN CASE.

STOCK NO.	RANGE INCH	BASE INCH	RODS
<b>ST12021604</b>	0-6	2-1/2	6

**ADDITIONAL MICROMETERS AVAILABLE  
UPON REQUEST**

**IF YOU DON'T SEE  
SOMETHING HERE  
YOU NEED,  
GIVE US A CALL.  
WE WILL DO  
OUR BEST  
TO FIND IT  
FOR  
YOU.**

**QUALITY  
PRODUCTS**  
**FAIR &  
COMPETITIVE  
PRICES**  
**EXCELLENT  
SERVICE**

**ST INDUSTRIES, INC.**

**PRECISION MEASURING TOOLS**

**ST INDUSTRIES, INC.**

**INSIDE-OUTSIDE COMBINATION SET**



INCLUDES ONE MANDREL OUTSIDE MICROMETER AND ONE INSIDE MICROMETER WITH HANDLE. OUTSIDE MICROMETER COVERS 0-4" RANGE. SOLID FORGED STEEL FRAME HAS LIGHTENING HOLES FOR GOOD FEEL AND BALANCE. INSIDE MICROMETER CAN REACH BORE DEPTHS UP TO 10". BLACK LINES AND NUMBERS FOR EASY READING. INCLUDES FITTED WOODEN CASE.

STOCK NO.	RANGE INSIDE	RANGE OUTSIDE	GRAD. INCH
ST11048501	1-1/2-8-1/2	0-4"	.001"

**MACHINIST TOOL KITS**



INCLUDES ONE 0-1" MICROMETER, ONE 6" DIAL CALIPER (ONE REVOLUTION), AND ONE 6" FULL-FLEX RULE. WITH FITTED WOODEN CASE.

STOCK NO. ST11000700



INCLUDES ONE 0-1" MICROMETER, ONE 6" DIAL CALIPER, ONE DEPTH MICROMETER (0-6" RANGE WITH A 4" BASE), AND A 6" FULL-FLEX RULE. FURNISHED WITH FITTED WOODEN CASE.

STOCK NO. ST11001200



COMPLETE WITH 11 BASIC ITEMS, INCLUDING A 0-1" MICROMETER, A 6" COMBINATION SQUARE SET, A 6" FULL-FLEX RULE, A 4" OUTSIDE SPRING CALIPER, A 4" INSIDE SPRING CALIPER, A 4" SPRING DIVIDER, AN ANGLE DEPTH GAUGE, AN ENGLISH CENTER GAUGE, A HERMAPHRODITE CALIPER, A POCKET SCRIBER AND A CENTER PUNCH. HIGH QUALITY TOOLS IN A FITTED WOODEN CASE.

STOCK NO. ST11000500

**MACHINIST APPRENTICE SET**

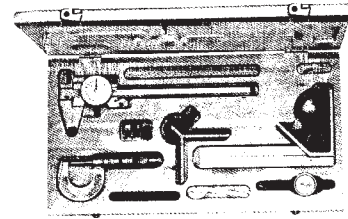

ALL HIGH QUALITY TOOLS ARE FURNISHED IN A FITTED WOODEN CASE, INCLUDING ONE 0-1" FULL-FINISH MICROMETER, ONE 6" DIAL CALIPER, ONE 6" FULL-FLEX RULE, A UNIVERSAL TEST INDICATOR, ONE 6" SQUARE BLADE, ONE SQUARE HEAD AND ONE CENTER HEAD.

STOCK NO. ST11000100

**6" SQUARE HEAD**



WITH LEVEL, SCRIBER AND CLAMP ASSEMBLY. HAS PRECISION-GROUND 90° SQUARE AND 45° MITER.

STOCK NO. ST26280000

**HARDENED STEEL SQUARE HEAD**



HAS 90° AND 45° MITER WITH CLAMP ASSEMBLY. INCLUDES SPIRIT LEVEL AND SCRIBER.

STOCK NO. ST26300000

**HARDENED STEEL CENTER HEAD**



WITH 45° ANGLES AND CLAMP ASSEMBLY.

STOCK NO. ST26310000

**REVERSIBLE PROTRACTOR**



PROTRACTOR HAS A SLOT IN CENTER FOR SHOULDER ON BOTH SIDES OF BLADE. COMES WITH LEVEL AND CLAMP ASSEMBLY. GRADUATED 180° WITH SPIRIT LEVEL.

STOCK NO. ST26320000

COMBINATION SETS OF THE ABOVE ITEMS IN THIS COLUMN ARE FEATURED ON THE NEXT PAGE



MEL'S SON RUSHED IN THE DOOR. "DAD! DAD!" HE ANNOUNCED. " I GOT A PART IN THE SCHOOL PLAY!"

"THAT'S TERRIFIC," MEL SAID PROUDLY. "WHAT PART IS IT?"

"I PLAY THE PART OF THE DAD."

MEL THOUGHT THIS OVER. "GO BACK TOMORROW," HE INSTRUCTED, "AND TELL THEM YOU WANT A SPEAKING ROLE."





PRECISION MEASURING TOOLS



**HARDENED STEEL SQUARE BLADES**



PRECISION-GROUND SQUARE BLADES MAY BE USED WITH ALL COMBINATION SQUARE COMPONENTS OR MAY BE USED SEPARATELY AS A RULE. NO. 4 GRADUATIONS. POLISHED.

STOCK NO. ST26331201 (12")

**6" COMBINATION SQUARE HEAD AND BLADE**



PRECISION-GROUND BLADE AND SQUARE HEAD MAY BE USED SEPARATELY AS A RULE AND LEVEL. SQUARE HEAD HAS SPIRIT LEVEL AND SCRIBER. POLISHED. 6" LENGTH.

STOCK NO. ST26240601 (NO. 4 GRADUATIONS)  
STOCK NO. ST26240611 (SATIN CHROME BLADE)

**6" COMBINATION SQUARE HEAD, CENTER HEAD AND BLADE**



SQUARE HEAD WITH SPIRIT LEVEL AND SCRIBER. PRECISION-GROUND BLADE. NO. 4 GRADUATIONS. POLISHED. 6" LENGTH.

STOCK NO. ST26250601

**COMBINATION SQUARE CLAMP ASSEMBLY**  
REPAIR KIT FOR ABOVE MACHINIST SQUARES  
INCLUDES NUT, SPRING AND SCREW CLAMP.

STOCK NO. ST48000000

**STARRETT COMBINATION SQUARES**

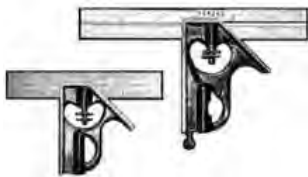

REVERSIBLE LOCK BOLT, SCRIBER, SPIRIT LEVEL AND HARDENED STEEL, MACHINE-DIVIDED BLADE. FORGED HARDENED STEEL HEADS WITH SMOOTH BLACK ENAMEL FINISH.

STOCK NO. LSSP50203 SIZE 4" (NO SPIRIT LEVEL)  
LSSP56392 6"

**STARRETT SQUARE ASSEMBLIES**  
REPAIR KIT FOR ABOVE MACHINIST SQUARES  
INCLUDES NUT, SPRING AND SCREW CLAMP.

STOCK NO. LSSPT99006 (12")  
LSSPT99004 (6")

**HARDENED STEEL COMBINATION SQUARE HEAD AND BLADE**

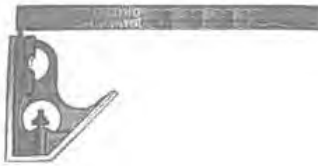

PRECISION-GROUND BLADE AND SQUARE HEAD MAY BE USED SEPARATELY AS A RULE AND LEVEL. SQUARE HEAD WITH SPIRIT LEVEL AND SCRIBER. NO. 4 GRADUATIONS. POLISHED. 12" LENGTH.

STOCK NO. ST26291201

**MASTER PRECISION LEVEL**



FOR ACCURATE CHECKING, SETTING AND ADJUSTING WORK OF MACHINISTS, TOOL-MAKERS AND INSPECTORS. AUXILIARY LEVEL VIAL SHOWS LATERAL POSITION AND ASSISTS IN HORIZONTAL SETTING. CASTING IS STABLE WITH WORKING SURFACE ACCURATELY MACHINED AND LAPPED. TOP PLATE INSULATES AGAINST HAND HEAT. GRADUATED TO .0005"/FT. BLACK WRINKLE FINISH. SUPPLIED IN FINISHED WOODEN CASE. 1-1/2 x 15".

STOCK NO. ST24006800

OUR INVENTORY IS EVERY EXPANDING... NEW PRODUCTS ARE ADDED REGULARLY. IF YOU DON'T SEE THE ITEM YOU NEED, CALL US ANYWAY, WE MAY HAVE ALREADY ADDED IT TO OUR INVENTORY!!

**DOUBLE SQUARE**

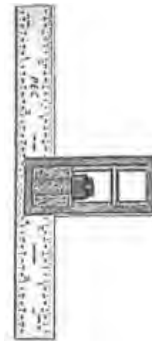

DOUBLE SQUARE HAS AN ADJUSTABLE HEAD, MAKING IT MORE VERSATILE THAN A COMMON SQUARE. POPULAR TOOL FOR MACHINISTS, TOOL-MAKERS AND PATTERN-MAKERS. BLADES ARE HARDENED AND TEMPERED. PRECISION-GROUND CAST-IRON HEAD. CHROME FINISH. GRADUATIONS: 1/8, 1/16, 1/32, 1/64.

STOCK NO. ST25003203

**TELESCOPING GAUGES**

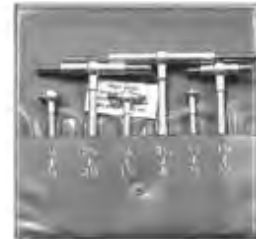

DESIGNED WITH A DOUBLE PLUNGER TO CHECK INSIDE MEASUREMENTS DIFFICULT TO OBTAIN WITH INSIDE MICROMETERS. COMPRESS PLUNGER AND LOCK INTO PLACE WITH SLIGHT TURN OF KNURLED KNOB ON HANDLE'S END. INSERT GAUGE INTO HOLE OR SLOT, RELEASE, AND PLUNGER EXPANDS TO EXACT SIZE. LOCK AGAIN AND REMOVE GAUGE TO TAKE MEASUREMENT. HARDENED RADIUS CONTACTS. SET OF SIX GAUGES. RANGE 5/16 - 6".

STOCK NO. ST64000700

**ELECTRONIC DIGITAL CALIPERS**

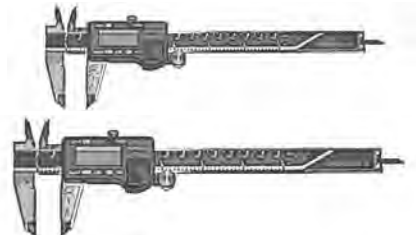

HARDENED STAINLESS STEEL. 4-WAY MEASUREMENT (ID, OD, DEPTH AND STEP). EXTRA-LARGE LCD READOUT. ENGLISH TO METRIC CONVERSION. 2,000 HR. LIFE SINGLE BATTERY. THUMB ROLLER AND LOCK. ZERO SETTING. ERROR AND LOW BATTERY ALARMS, LAPPED MEASURING FACES. CASE AND BATTERY INCLUDED. .001" ACCURACY. 32° - 104°F OPERATING TEMPERATURE.

**ECONOMY DIGITAL CALIPERS**

STOCK NO.	RANGE	RESOLUTION
STC7251006	0-6"	.0005"
AVEMC0008	0-8"	.0005"
AVEMC0012	0-12"	.0005"

*Moody*

**PRECISION MINIATURE TOOLS**

*Moody*

**MACHINIST SCRIBERS**

BENT AND STRAIGHT POINTS ARE HARDENED, ALL-ALLOY STEEL. MILD STEEL HOOK POINT IDEAL FOR OIL SEAL REMOVAL & SPRING ADJUSTMENTS. 1/4" DIAMETER KNURLED HANDLE. 8" OVERALL LENGTH.

**FIXED STRAIGHT & 90° BENT POINTS SCRIBER**



**STOCK NO. MOOD511510**

**FIXED STRAIGHT & MILD STEEL HOOK SCRIBER**



**STOCK NO. MOOD511511**

**ADJUSTABLE HANDLE SCRIBER**



BOTH POINTS ARE HARDENED, HEAT TREATED ALLOY STEEL. 5/16" DIAMETER ADJUSTABLE HANDLE. 8-5/8" OVERALL LENGTH. STRAIGHT & 90 DEGREE BENT POINTS.

**STOCK NO. MOOD5115**

**?? QUESTIONS ??**



**CALL US  
WE  
WANT  
TO  
HELP!**

**CARBIDE POINT POCKET SCRIBER**



REVERSIBLE POINT SCRIBER WITH MAGNET & CLIP. 5-1/2" OVERALL LENGTH.

**STOCK NO. MOOD511521**

**MINIATURE TOOL SETS**

**12 PIECE SLOTTED SCREWDRIVER SET**



INCLUDES 6 BLADES AND 6 HANDLES. SIZES: .025, .040, .055, .070, .080, & .100 VINYL POUCH.

**STOCK NO. MOOD580116**

**11 PIECE MINI-TOOL SET**



INCLUDES 4 SLOTTED, 2 CROSS RECESS, 3 HEX, 1 AWL & 1 HANDLE. VINYL POUCH.

**STOCK NO. MOOD580119**

**4 PIECE PIN VISE SET**



FOUR INDIVIDUAL VISES WITH CAPACITIES RANGING FROM .000 to .187. EACH VISE FEATURES A SOLID-LOCKING, SPRING TEMPERED STEEL COLLET FOR EXACTING WORK. VINYL POUCH.

**STOCK NO. MOOD580196**

HALF OUR LIFE IS SPENT TRYING TO FIND SOMETHING TO DO WITH THE TIME WE HAVE RUSHED THROUGH LIFE TRYING TO SAVE.  
--WILL ROGERS

**MINIATURE TOOL SETS  
(CONTINUED)**

**5 PIECE MAGNETIC SCRIBER/PICK SET**



THREADED MAGNETIC SCRIBERS INCLUDE HOOKED POINT, STRAIGHT POINT, ANGLED POINT, AND 90° BENT POINT. VINYL POUCH.

**STOCK NO. MOOD580224**

**41 PIECE COMBINATION TOOL SET**



INCLUDES 15 SOLID-LOCKING KNURLED HANDLES, FOUR SLOTTED SCREWDRIVER BLADES (.055 - .125), TWO PHILLIPS BLADES (.100, .125), ONE JIS-TYPE S BLADE (.080), THREE HEX DRIVER BLADES (.050, .062, .078), FIVE SOCKET WRENCH BLADES (5/64 - 5/32), EIGHT SHORT ARM HEX KEYS (1/16 - 1/4), ONE FINE-POINT AWL, ONE 4" PAIR OF STAINLESS STEEL TWEEZERS, AND ONE BALL-END HANDLE.

**STOCK NO. MOOD580252**

**8 PIECE SHORT ARM HEX KEY SET**



INCLUDES 8 SHORT ARM HEX KEYS RANGING IN SIZE FROM: 1/16, 5/64, 3/32, 1/8, 5/32, 3/16, 7/32, 1/4.

**STOCK NO. MOOD580254**

**ADDITIONAL  
PRECISION MINIATURE TOOLS  
AND SETS AVAILABLE UPON  
REQUEST**



**ELECTRONIC TESTING INSTRUMENTS**



**THERMOMETERS**

**1" POCKET DIAL THERMOMETER**



1" DIAL WITH POCKET CLIP SHEATH. PLASTIC WATERTIGHT LENS. RECALIBRATION NUT. STAINLESS STEEL CONSTRUCTION. DUAL SCALE 5" STEM. 2° DIVISION. RANGE- 0° TO 220° F.

**STOCK NO. UIT220**

**DIGITAL PEN THERMOMETER**



NSF APPROVED. 5-3/4" LENGTH. RUGGED. WATER RESISTANT. EASY TO READ. DATA HOLD AND CONTINUOUS UPDATE. AUTO POWER OFF. RANGE- -40° TO 300° F. LOW BATTERY INDICATION. BUTTON BATTERY. 3" STEM.

**STOCK NO. UIPDT550**

**DIGITAL POCKET THERMOMETER**



NSF APPROVED. EASY TO READ. DATA HOLD. AUTO POWER OFF. 5" STEM. BUTTON BATTERY. WATER RESISTANT. RUGGED. LOW BATTERY INDICATION. RANGE -40° TO 300° F. ECONOMICAL.

**STOCK NO. UI550**

**TEMPERATURE TESTER**



MEASURE TEMPERATURE AT 4 SEPARATE LOCATIONS. IDEAL FOR SUPERHEAT AND HEAT PUMP TEMPERATURE MEASUREMENTS. RUGGED. EASY TO READ. DATA HOLD. MIN/MAX FUNCTION RECORDS HIGHS AND LOWS. DUAL RANGE- -40° TO 300° F. AND -40° TO 150° C. INCLUDES (2) 15' FAST RESPONSE PROBES, (2) PIPE STRAPS, NECK STRAP AND 1.5V AA BATTERY.

**STOCK NO. UIDT40**

**TEMPERATURE ADAPTER**



K-TYPE THERMOMETER TEMPERATURE ADAPTER FOR DMMs WITH 200mV AND/OR 2 V DC RANGES. PLUGS DIRECTLY INTO COM AND DCV INPUT JACKS. A BATTERY AND 4 FT. TEMPERATURE PROBE ARE INCLUDED. USED WITH DM383B.

**STOCK NO. UITA1K**

**DIGITAL MULTIMETERS**



EASY TO READ AND USE. MEASURES TRUE RMS AC VOLTS AND AMPS. AUTORANGING FEATURE. DIODE CHECK FUNCTION. INCLUDES RUBBERIZED TEST LEAD SET, BOOT, FUSES AND 9V BATTERY.

**STOCK NO. UIDM393**

**DIGITAL MULTIMETERS**



AN ECONOMICAL DIGITAL MULTIMETER THAT YOU CAN USE FOR FAST AND SURE CHECKS OF VOLTAGE, CONTINUITY OR RESISTANCE. 600 VOLTS AC AND DC. RESISTANCE TO 200 OHMS WITH MANUAL RANGING.

**STOCK NO. UIDM200**



WIDE CAPACITANCE RANGE. FEATURES EASY TO READ DISPLAY, AUTO POLARITY, DATA HOLD, OVER RANGE AND LOW BATTERY INDICATION, CONTINUITY BEEPER AND DIODE CHECK FUNCTION. INCLUDES RUBBERIZED TEST LEAD SET, BOOT, 9V BATTERY, FUSES AND CAPACITANCE FUSE. ACCURATE DOWN TO 1/10th OF A MICRO-AMP.

**STOCK NO. UIDM383B**

**CLAMP-ON ADAPTER**



CONVERT YOUR DMM INTO A CLAMP-ON METER. MEASURES AC CURRENT ONLY AND IS COMPATIBLE WITH DM383B. COMPACT.

**STOCK NO. UICA383B**

**CALL  
AND  
SEE  
WHY WE ARE  
A  
GREAT  
SOURCE FOR  
INDUSTRIAL  
SUPPLIES!**

**CALL US FOR ALL YOUR NEEDS  
855-785-TOOL**

ADDITIONAL PRODUCTS CONTINUED  
NEXT PAGE

**ELECTRONIC TESTING INSTRUMENTS**

**DIGITAL CLAMP-ON METERS**



ACCESS HARD-TO-REACH WIRING WITH TEARDROP JAW. MEASURE TO 1000 AMPS AC. PEAK HOLD FOR ALL VOLT AND AMP RANGES. CONTINUITY BEEPER. RUGGED. INCLUDES TEST LEADS, 9V BATTERY AND CARRYING CASE.

**STOCK NO. UIDL99B**



AN ALL PURPOSE CLAMP-ON MULTIMETER LOADED WITH FEATURES. THE COMPLETE PACKAGE INCLUDING TEST LEADS, TEMPERATURE PROBE ADAPTER AND THERMOCOUPLE IS IDEAL FOR HVAC/R, ELECTRICAL AND INDUSTRIAL SERVICE PROFESSIONALS. TIME-STAMPED RECORD FUNCTION. AUTO-RANGING WITH MANUAL RANGING CAPABILITY.

**STOCK NO. UIDL379**

**IF YOU DON'T SEE  
SOMETHING HERE  
YOU NEED,  
GIVE US A CALL.  
WE WILL DO  
OUR BEST  
TO FIND IT  
FOR YOU!**

**COMPACT ANALOG MULTIMETERS**



21 RANGES. TEST THERMOCOUPLES WITH DC mV RANGES. COLOR CODED SCALE PLATE AND FRONT PANEL. DIODE PROTECTED METER MOVEMENT. RIGHT ANGLE SAFETY TEST LEADS. INCLUDES BATTERIES, FUSE AND CARRYING CASE.

**STOCK NO. UIM110A**



ECONOMICAL. 16 RANGES. FUSE PROTECTED. DIODE PROTECTED METER MOVEMENT. COLOR CODED FOR EASY USE. TEST LEADS INCLUDED. AA BATTERIES SOLD SEPARATELY.

**STOCK NO. UIUTL2K**

**COMPACT DIGITAL MULTIMETERS**



THIS POCKET-SIZED METER OFFERS THE FUNCTIONS AND ACCURACY TYPICALLY FOUND IN FULL-SIZED MULTIMETERS. 750 VOLT AC AND DC. 5 AMPS AC AND DC. RESISTANCE TO 30 MEGOHMS. AUTO-RANGING. FUSE PROTECTED CURRENT RANGES.

**STOCK NO. UIDM5B**

**CLAMP-ON ANALOG MULTIMETER**



9 RANGES. RUGGED. TWIST-LOCK TEST LEADS PROTECT METER. BUILT-IN FUSE PROTECTED CIRCUIT. ABLE TO CHECK LINE VOLTAGES AND CONTINUITY. COLOR CODED SCALE PLATE. SCALE PLATE MAGNIFIER LENS. POINTER LOCK SWITCH. 1-1/2" JAW CAPACITY. CARRYING CASE.

**STOCK NO. UIMCP9A**

**ELECTRONIC TESTING INSTRUMENT ACCESSORIES**



**TEST LEADS**

COMPATIBLE WITH DM383, DM420, DL100. **STOCK NO. UIATL55**

SET OF TWO 32" LEADS. RED AND BLACK. ALLIGATOR CLIPS ON EACH END. **STOCK NO. VA69128**

**POCKET SIZE TESTER**



POCKET SIZE ELECTRICAL TESTER. ALLOWS INSTANT TESTING OF 110 VAC OUTLETS. PLUGS INTO ANY STANDARD 110 VAC OUTLET. INSTANT DISPLAY OF WIRING CONDITION FOR STANDARD OUTLET.

**STOCK NO. UIECT120K**



POCKET SIZE ELECTRICAL TESTER/GFCI. USED FOR TEST 110 VAC OUTLETS. INSTANT TESTING OF CIRCUIT BREAKER IN GFI OUTLETS WITH GROUND FAULT BUTTONS. INSTANT DISPLAY OF WIRING CONDITION FOR STANDARD OUTLET.

**STOCK NO. UIECTGFIK**

**ADDITIONAL TESTING EQUIPMENT  
AVAILABLE UPON REQUEST**

NOTHING SO NEEDS REFORMING AS OTHER PEOPLE'S HABITS.

--MARK TWAIN



**ELECTRONIC TESTING INSTRUMENTS**



**INFRARED THERMOMETER**



THE AFFORDABLE INF155 PUTS THE CONVENIENCE OF NON-CONTACT TEMPERATURE TESTING IN THE PALM OF YOUR HAND. THE PISTOL-GRIP HANDLE PROVIDES SUPERIOR COMFORT AND CONTROL, WHILE HIGH TEMPERATURE TESTING AND LASER TARGETING ADD SPEED, ACCURACY AND SAFETY TO YOUR MAINTENANCE AND TROUBLESHOOTING PROCEDURES.

**STOCK NO. UIINF155**

**INFRARED THERMOMETER**



INFRARED THERMOMETER IS A RELIABLE WAY TO CHECK, LOCATE AND MONITOR TEMPERATURE VARIANCES. PERFECT FOR HVAC, ELECTRICAL, INDUSTRIAL, AUTO, ETC. DIAGNOSTICS AND MAINTENANCE COMES WITH CARRYING STRAP, PROBE, BATTERIES AND A WIDE RANGE OF DEPENDABLE FEATURES.

**STOCK NO. UIINF185**

**ANALOG INSULATION RESISTANCE TESTER**



PORTABLE, BATTERY-POWERED INSTRUMENT. NO HAND CRANKING. LOCATE AND MEASURE INTERMITTENT SHORTS, DEFECTIVE ELECTRICAL CONNECTIONS, INSULATION BREAKDOWNS AND CONDUCTOR FAILURES. COLOR CODED SCALE. INCLUDES TEST LEADS, BATTERIES AND FUSES.

**STOCK NO. UIIRT3**



**ALLIGATOR CLIPS**



**STOCK NO. AC001** (RED 5 AMP)  
**STOCK NO. AC002** (BLACK 5 AMP)

**ALLIGATOR CLIPS WITH VINYL BOOTS**



**STOCK NO. AC003** (RED INSULATION 5 AMP)  
**STOCK NO. AC004** (BLACK INSULATION 5 AMP)

**ALLIGATOR CLIPS WITH VINYL BOOTS**



**STOCK NO. AC005** (RED INSULATION 10 AMP)  
**STOCK NO. AC006** (BLACK INSULATION 10 AMP)

**JAW TYPE ALLIGATOR CLIPS**



**STOCK NO. AC007** (10 AMP)  
**STOCK NO. AC008** (25 AMP)  
**STOCK NO. AC009** (50 AMP)

**MISCELLANEOUS VOLTAGE TESTERS AND ACCESSORIES**

**AC SENSOR**

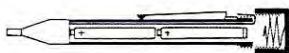

PREVENT ELECTRICAL SHOCK. LOCATES ELECTRICITY THROUGH INSULATION. DETECTS 110 - 600 VOLTS AC. BRIGHT RED GLOW ON TIP INDICATES VOLTAGE. SENSES VOLTAGE WITHOUT METALLIC CONTACT. DETECTION WILL SOUND ALERT.

**STOCK NO. SANT3000**

**LOW VOLTAGE TESTER**



CHECK SHORTS, BREAKS, GROUNDS IN WIRING AND FIELD COILS, LOOSE CONNECTIONS, ETC.

**STOCK NO. CTA3024**

**CONTINUITY TESTER**



SELF-CONTAINED POWER UNIT TESTS CIRCUITS WITH POWER OFF. BATTERY NOT INCLUDED.

**STOCK NO. RIM1050**

**WIGGY SOLENOID VOLTAGE TESTER**



FOR 120V TO 600V AC OR DC CURRENTS. LOCATES BLOWN FUSES, GROUNDS AND SYSTEM LEAKS. PROD ASSEMBLIES HAVE RETRACTABLE PROTECTIVE SLEEVES THAT ADJUST. TEST LEADS ARE 28" LONG

(INCLUDING PROD MODULE).

**STOCK NO. VA69115**

**MULTI-VOLT TWIN LEAD TESTER**



TESTS FOR DC POLARITY, FREQUENCY AND POLYPHASE LINE. CHECKS VOLTAGE ON CIRCUITS UP TO 460V (AC OR DC). COMBINATION OF GLOW LAMPS INDICATE VOLTAGE BEING TESTED- 110, 220, 277 OR 460 VOLTS. TEST LEADS FURNISHED WITH PROBES.

**STOCK NO. VA69135**

THE SHORTEST RECORDED PERIOD OF TIME LIES BETWEEN THE MINUTE YOU PUT SOME MONEY AWAY FOR A RAINY DAY AND THE UNEXPECTED ARRIVAL OF RAIN.

--JANE BRYANT QUINN

## TAPE MEASURES

### 1/2" LOCKING TAPE RULE



IMPACT-RESISTANT CHARCOAL CASE. EXCLUSIVE "TOUGH-TIP" BLADE PROTECTOR REINFORCES TAPE BLADE END. RUST RESISTANT YELLOW LACQUERED BLADE IS MARKED

IN RED AND BLACK WITH STUD MARKS EVERY 16 INCHES.

STOCK NO.	DESCRIPTION	BOX QTY.
LSS65942	1/2" x 12'	6
	METRIC/ENGLISH	
LSS65944	1/2" x 12'	6

### 3/4" LOCKING TAPE RULE



STOCK NO.	DESCRIPTION	BOX QTY.
LSS66168	3/4" x 12'	6
LSS65937	3/4" x 16'	6
LSS65940	3/4" x 25'	6
	METRIC/ENGLISH	
LSS65939	3/4" x 16'	6

### 1" LOCKING TAPE RULE



CHROME PLATED CASE. SAME OUTSTANDING FEATURES AS CHARCOAL "TRU-LOCK" WITH "TOUGH-TIP" BLADE PROTECTOR. STARRETT PRECISION AND EXCELLENCE.

STOCK NO.	DESCRIPTION	BOX QTY.
LSS65366	1" x 25'	6
LSS65382	1" x 30'	6

### MAGNESIUM TAPE RULER



NON-SLIP RUBBER GRIP. MAGNESIUM CASE GIVES IT A LONGER LIFE AND MAKES IT ONE OF THE RARE TRUE METAL CASED TAPE MEASURES.

STOCK NO.	DESCRIPTION
LSS66993	1" x 25'

### TAPE REFILLS



STOCK NO.	DESCRIPTION
LSS63294	3/8" x 50'
LSS63295	3/8" x 100'
LSS65436	1/2" x 12'
LSS66256	3/4" x 12'
LSS65352	3/4" x 16'
LSS65357	3/4" x 25'
LSS65435	1" x 25'
LSS65437	1" x 30'

### LUFKIN "HI-VIZ" TAPE RULE



3" BASE FOR INSIDE MEASUREMENTS. SHOCK ABSORBER PROTECTS END HOOK ON RETURN. ERGO DESIGN FOR COMFORT. CLEAR COAT BLADE PROTECTION. STUD MARKINGS ON 16" & 19.2"

STOCK NO.	DESCRIPTION
LUFHV1433	1" x 33'

### LUFKIN "HI-VIZ" MINI TAPE RULE



POWER RETRACTION OPERATION. CONVENIENT SMALL SIZE. CLEAR COAT BLADE PROTECTION. DURABLE HIGH IMPACT CASE.

STOCK NO.	DESCRIPTION
LUFW616	1/4" x 6'

### TOUGH TAPE RULE



LOCKING, PRECISION TAPE MEASURE. IMPACT RESISTANT RUGGED CASE. DURABLE STAINLESS STEEL BELT CLIP.

STOCK NO.	DESCRIPTION
LSS68934	1" x 25'

### 3/8" LONG LINE TAPES



BLACK GRADUATIONS ON YELLOW STEEL TAPE WITH HOOK. NYLON ROLLERS AT OPENING REDUCE WEAR, PREVENT DAMAGE TO TAPE LINE. RED VINYL COVERING OVER ELECTRO-PLATED STEEL CASE.

STOCK NO.	DESCRIPTION
LSS65988	3/8" x 50' (PLASTIC CASE)
LSS65945	3/8" x 50'
LSS65946	3/8" x 100'

### EXTENSION WOOD FOLDING RULE



SIX FEET LONG, WITH SIX INCH EXTENSION FOR MEASURING BETWEEN DOORS, WINDOWS, ETC. DEEPLY EMBOSSED AND SEALED NUMERALS WITH 16 INCH STUD CENTER MARKINGS IN RED.

STOCK NO.	TYPE
LSS63177	REGULAR (OUTSIDE) READING
	WITHOUT EXTENSION
LSS63179	REGULAR (OUTSIDE) READING
LSS63180	FLAT (INSIDE) READING

IF YOU DON'T SEE SOMETHING HERE YOU NEED, CALL US

**CALL AND SEE US MAKE THE DIFFERENCE!!**

THE INMATE WAS AWARE THAT ALL PRISON MAIL PASSES THROUGH CENSORS. WHEN HE GOT A LETTER FROM HIS WIFE ASKING ABOUT THE FAMILY GARDEN - "HONEY, WHEN DO I PLANT POTATOES?"--HE WROTE BACK, "DO NOT, UNDER ANY CIRCUMSTANCES, DIG UP OUR OLD GARDEN SPOT. THAT'S WHERE I BURIED ALL MY GUNS."

WITHIN DAYS HIS WIFE WROTE BACK, "SIX INVESTIGATORS CAME TO THE HOUSE. THEY DUG UP EVERY SQUARE INCH OF THE BACK YARD."

BY RETURN MAIL SHE GOT HIS ANSWER: "NOW IS THE TIME TO PLANT POTATOES."

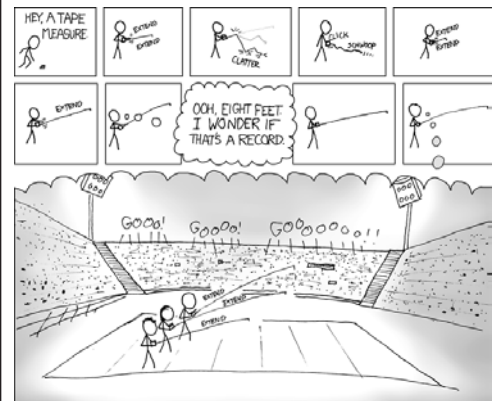

**ECONOMY TAPE MEASURES AND SPECIAL USE TAPES**

**THE PROFESSIONAL NYLON COATED BLADE**



ERGONOMICALLY DESIGNED CASE PROVIDES EASY TO HOLD GRIP. SUPERIOR INTERNAL MECHANISM PROVIDES SMOOTH OPERATION. NYLON COATED BLADE FOR MAXIMUM DURABILITY.

STOCK NO	DESCRIPTION
KOM4925	1" x 25'
KOM4933	1" x 33'

**1" SELF-LOCKING TAPE RULE**



SELF LOCKING MECHANISM ALLOWS BLADE TO BE EXTENDED SMOOTHLY. PUSH BUTTON ALLOWS BLADE TO BE RETRACTED SMOOTHLY. NYLON COATED BLADE FOR MAXIMUM DURABILITY.

PRINTED FRACTIONAL GRADUATIONS FOR EASY READ AND ACCURATE MEASUREMENTS.

STOCK NO	DESCRIPTION
KOMSL2925	1" x 25'

**GRIPPER X TAPE RULE**



30% LARGER NUMBERS FOR EASIER READING. COMPACT RUBBERIZED CASE FITS COMFORTABLY IN HAND. LARGE FLARED END HOOK HOLDS BLADE FIRMLY IN PLACE.

STOCK NO	DESCRIPTION
KOM2125	1" x 25'
KOM2135	1" x 35'

**GRIPPER RULE**



FRACTIONAL GRADUATION. FRACTIONAL SCALE WITH EVERY 1/8" PRINTED. IMPACT ABSORBING RUBBER JACKET PROTECTS

CASE AND TIP. BUILT-IN SHOCK ABSORBER TO PROTECT BLADE AND END HOOK. EASY TO READ WHITE BLADE ON BLACK RULE.

STOCK NO.	DESCRIPTION	COLOR
KOM5425	1" x 25'	BLACK
KOM5925	1" x 25"	YELLOW

THE MOST VALUABLE OF ALL TALENTS IS THAT OF NEVER USING TWO WORDS WHEN ONE WILL DO.

--THOMAS JEFFERSON

**GRIPPER SPEED MARK RULE**



FRACTIONAL GRADUATION. FRACTIONAL SCALE WITH EVERY 1/8" PRINTED. EASY GRIP THICK RUBBER JACKET. EASY TO READ WHITE BLADE.

STOCK NO	DESCRIPTION
KOMSM5425	1" x 25'

**GRIP LOCK TAPE**



PAUSE BUTTON TO HOLD BLADE FIRMLY, ALLOWS SAFE AND PRECISE MEASUREMENT. ERGONOMICALLY DESIGNED CASE WITH MOLDED RUBBER GRIP. NYLON COATED BLADE

FOR MAXIMUM DURABILITY.

STOCK NO	DESCRIPTION
KOM6210	5/8" x 10'

**MAGNETIC GRIP LOCK TAPE RULE**



ERGONOMICALLY DESIGNED CASE WITH MOLDED RUBBER GRIP. PAUSE BUTTON TO HOLD BLADE FIRMLY IN PLACE. NYLON COATED BLADE FOR MAXIMUM DURABILITY. LARGE

FLARED MAGNETIC END HOOK FOR EASIER ONE PERSON MEASUREMENTS.

STOCK NO.	DESCRIPTION
KOMW6725	1" x 25'

**MONSTER MAG-GRIP RULE**



MAGNETIC DUAL END HOOK ALLOWS FOR EASIER ONE PERSON MEASUREMENT. DOUBLE SIDED PRINTING PROVIDES PRECISE MARKING AND LINE DRAWING. IMPACT

RESISTANT RUBBERIZED CASE PROTECTS END HOOK AND BUTTON.

STOCK NO	DESCRIPTION
KOM7116	1" x 16'

**METRIC/FRACTIONAL TAPE RULE**



ERGONOMICALLY DESIGNED CASE PROVIDES EASY TO HOLD GRIP. SUPERIOR INTERNAL MECHANISM PROVIDES SMOOTH OPERATION. NYLON COATED BLADE FOR MAXIMUM DURABILITY.

STOCK NO.	DESCRIPTION
KOM4925IM	1" x 25'

**OPEN REEL FIBERGLASS TAPE**



HIGH IMPACT RESISTANT ABS CASE. DOUBLE COATED BLADE FOR MAXIMUM DURABILITY.

STOCK NO.	DESCRIPTION
KOM6611	1/2" x 100'
KOM6622	1/2" x 200'
KOM6633	1/2" x 300'

**OPEN REEL FIBERGLASS TAPE**



EASY READ 1/2" YELLOW BLADE. TWO COLOR PRINTING. THE ABS FRAME HAS A CONVENIENT HAND GRIP AND LARGE ROLLER ARM FOR EASY WINDING.

STOCK NO.	DESCRIPTION
EM6799	1/2" x 100'

**ATHLETIC FIELD STEEL TAPE**



GLARE-PROOF, CLEAR NYLON COATING PROTECTS FROM CORROSION. FLEXIBLE HIGH-TEMPERED STEEL BLADE WILL NOT STRETCH. INCH AND ENGINEERS 1/10TH GRADUATIONS.

STOCK NO.	DESCRIPTION
EM6720	3/8" x 200'

**FIBERGLASS RULE CLOSED CASE**



FOLDING REWIND CRANK PROVIDES FAST BLADE RETRIEVAL. NYLON COATED BLADE FOR MAXIMUM DURABILITY.

STOCK NO	DESCRIPTION
KOM350	1/2" x 50'

**NON-METALLIC FIBERGLASS TAPE**



EASY READ 1/2" YELLOW BLADE. TWO COLOR PRINTING. VINYL COVERED STEEL CONVENIENT HOOK HANDLE.

STOCK NO.	DESCRIPTION
EM6100	1/2" x 100'

## CHALK LINE REELS AND INDUSTRIAL LEVELS

### KEY CADDY



LONG LASTING CHROME PLATED DIE CAST CASE. STAINLESS STEEL CHAIN. GREAT FOR PERSON WHO NEEDS EASY ACCESS TO THEIR KEYS.

STOCK NO. LSS63135

### "STRAIT-LINE" TOP QUALITY CHALK LINE REEL



PRECISION MADE, SELF-CHALKING PROVIDES SHARP, CLEAR LINE EVERY TIME. CONVENIENT SLIDE-FILL OPENING FOR NO-MESS CHALK REFILLS. LEAK-PROOF, PRACTICALLY DAMAGE PROOF. 50' AND 100' LENGTHS. DESIGNED TO DOUBLE AS PLUMB BOB.

STOCK NO.	LENGTH
IR63950	50 FT.
IR64110	100 FT.

### REPLACEMENT LINES

TOP QUALITY NYLON LINE WOUND ON "POP-IN" SPOOL. CAN BE WOUND INTO OTHER TYPES OF REELS.

STOCK NO.	LENGTH
LSS63166	50 FT.
LSS63167	100 FT.

### POWDERED CHALK REFILLS

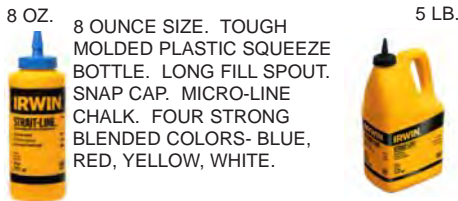

8 OZ. 8 OUNCE SIZE. TOUGH MOLDED PLASTIC SQUEEZE BOTTLE. LONG FILL SPOUT. SNAP CAP. MICRO-LINE CHALK. FOUR STRONG BLENDED COLORS- BLUE, RED, YELLOW, WHITE.

5 LB.

STOCK NO.	COLOR
IR64901	BLUE (8 OZ.)
IR64902	RED (8 OZ.)
IR64903	YELLOW (8 OZ.)
IR64904	WHITE (8 OZ.)
IR65101	BLUE (5 LB.)
IR65102	RED (5 LB.)
IR65103	YELLOW (5 LB.)
IR65104	WHITE (5LB.)
IR65105	FLUORESCENT ORANGE (5LB.)
IR65106	FLUORESCENT LIME (5LB.)

### LINE REELS

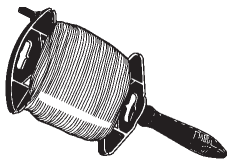

ORANGE NYLON BRAIDED LINE. UNIQUE HANDLE DESIGN FOR QUICK DISBURSEMENT AND REWIND OF LINE. 500' LENGTH.

STOCK NO. EM39513N

### BRASS BOUND MAHOGANY LEVEL (PROFESSIONAL)



FULL BRASS BOUND MAHOGANY FRAME, OVERSIZED VIAL TUBES.

STOCK NO.	DESCRIPTION
LSS36016	48" 6 VIALS (4 PLUMB, 2 LEVEL), OPEN GRIPS

### STA-TRUE LEVEL (ECONOMY)



MEDIUM DUTY ALUMINUM FRAME, 360° YELLOW "CAT'S EYE" VIALS.

STOCK NO.	DESCRIPTION
LSS36044	24", 3 VIALS (2 PLUMB, 1 LEVEL), OPEN GRIPS
LSS36048	48", 3 VIALS (2 PLUMB, 1 LEVEL), OPEN GRIPS

### STA-TRUE LEVEL (PROFESSIONAL)



HEAVY DUTY ALUMINUM FRAME, 360° YELLOW "CAT'S EYE" VIALS, REPLACEABLE VIAL SYSTEM.

STOCK NO.	DESCRIPTION
LSS36053	24", 3 VIALS (1 PLUMB, 1 LEVEL, 1 45°), OPEN GRIPS
LSS36055	36", 3 VIALS (2 PLUMB, 1 LEVEL), OPEN GRIPS
LSS36056	48", 3 VIALS (2 PLUMB, 1 LEVEL), OPEN GRIPS
LSS36057	72", 5 VIALS (3 PLUMB, 2 LEVEL), OPEN GRIPS
LSS36059	96", 5 VIALS (3 PLUMB, 2 LEVEL), OPEN GRIPS

### DIE CAST ALUMINUM LEVEL (PROFESSIONAL)



EXTREMELY STABLE, DIE-CAST CONSTRUCTION. WORKING EDGES GROUND FOR ACCURACY, ONE EDGE RULED.

STOCK NO.	DESCRIPTION
LSS36022	24" 6 VIALS (4 PLUMB, 2 LEVEL),

### TORPEDO LEVEL



CAST ALUMINUM FRAME, 360° VIALS, TOP READING LEVEL SIGHT.

STOCK NO.	DESCRIPTION
LSS36069	9", 3 VIALS (1 PLUMB, 1 LEVEL, 1 45°), GROOVED BASE
LSS36070	9" 3 VIALS (1 PLUMB, 1 LEVEL, 1 45°), MAGNETIC BASE LEVEL, PITCH/SLOPE VIAL
LSS36071	9" 3 VIALS (1 PLUMB, 1 LEVEL, 1 45°), V-GROOVED TOP EDGE FOR PLUMBING AND TUBULAR WORK, MAGNETIC BASE.

### ECONOMY TORPEDO LEVEL



9" CAST ALUMINUM FRAME, 360° VIALS, TOP READING LEVEL SIGHT. V-GROOVED WORKING EDGE FITS ON PIPE OR CONDUIT. VIALS READ PLUMB, LEVEL AND 45°.

STOCK NO. EM587

### LINE/SURFACE LEVEL



ALUMINUM FRAME, 360° VIAL, LINE HOOK.

STOCK NO.	DESCRIPTION
LSS36077	3" 1 LEVEL VIAL, LINE HOOKS

### MAGNETIC LEVELS



HEAVY DUTY ALUMINUM FRAME, LARGE WORKING EDGE MAGNET, 360° VIALS, REPLACEABLE VIAL SYSTEM.

STOCK NO.	DESCRIPTION
LSS36062	24", 3 VIALS (2 PLUMB, 1 LEVEL), OPEN GRIPS
LSS36064	48", 3 VIALS (2 PLUMB, 1 LEVEL), OPEN GRIPS

IF A SMALL THING HAS THE POWER TO MAKE YOU ANGRY, DOES THAT NOT INDICATE SOMETHING ABOUT YOUR SIZE?  
--STANLEY HOROWITZ



**MAGNETIC LEVELS, STRAIGHT EDGES, AND MEASURING WHEELS**

**ROBUST LEVELS**



EXCLUSIVE 4 CHAMBER PROFILE STRENGTHENS THE LEVEL AGAINST BENDING IN EITHER DIRECTION. EASY TO SEE 300° RADIUS. WITH HAND HOLDS. 3 VIALS (2 PLUMB, 1 LEVEL)

STOCK NO. DESCRIPTION

<b>BMI698060</b>	24"
<b>BMI698090H</b>	36"
<b>BMI698120H</b>	48"

**SUPER ROBUST LEVELS**



DESIGNED FOR THE LONG LEVEL (6'+) MARKET WHERE MOST BENDING PROBLEMS OCCUR. 500% STRONGER THAN ROBUST LEVELS. ACCURACY 1/64" PER YD. COMES WITH 2 UNABRIDGED H VIALS. WITH HAND HOLDS.

STOCK NO. DESCRIPTION

<b>BMI695180H</b>	72"
<b>BMI695200H</b>	78"
<b>BMI698120H</b>	48"

**MAGNETIC LEVEL**



USES POWERFUL PERMANENT MAGNETS. 1/64" PER YARD ACCURACY. MILLED SURFACES ON LEVEL 4' AND SHORTER ALLOW THE LEVEL TO BE READ UPSIDE DOWN.

STOCK NO. DESCRIPTION

<b>BMI698M120</b>	48", 4 CHAMBER PROFILE
-------------------	------------------------

**EURO LEVEL**



OVERSIZED VERTICAL AND HORIZONTAL VIAL, THE LATTER ALSO HAS THE 2% SCOPE ETCHED ON IT. SUPERB ACCURACY (1/64" PER YD.) IN A "VALUE" PRICED LEVEL.

STOCK NO. DESCRIPTION

<b>BMI690120</b>	48"
------------------	-----

**SUPER TORPEDO LEVEL**



COMES WITH PERMANENT HEAVY DUTY MAGNETS. ACCURATE TO 1/64" PER YD. UNIQUE TOP READ PLUMB VIAL CAN BE SEEN FROM TOP, FRONT, OR SIDE. WITH FIXED OR ADJUSTABLE VIAL.

STOCK NO. DESCRIPTION

<b>BMI693M025</b>	10", FIXED VIAL
<b>BMI693WM025</b>	10", ADJUSTABLE VIAL

**ECONOMY CARPENTER SQUARE**

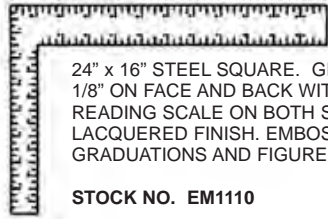

24" x 16" STEEL SQUARE. GRADUATIONS 1/8" ON FACE AND BACK WITH REVERSE READING SCALE ON BOTH SIDES. LACQUERED FINISH. EMBOSSED GRADUATIONS AND FIGURES.

STOCK NO. EM1110

**CARPENTER SQUARE**

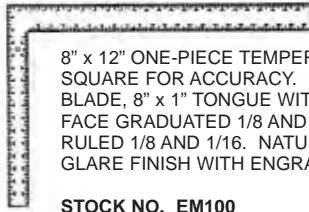

8" x 12" ONE-PIECE TEMPERED STEEL SQUARE FOR ACCURACY. 12" x 1-1/2" BLADE, 8" x 1" TONGUE WITH HANG HOLE. FACE GRADUATED 1/8 AND 1/16. BACK RULED 1/8 AND 1/16. NATURAL NON-GLARE FINISH WITH ENGRAVED SCALE.

STOCK NO. EM100

**ALUMINUM STRAIGHT EDGE RULE**

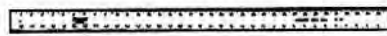

FLEXIBLE ANODIZED ALUMINUM CONSTRUCTION. PARALLEL AND ACCURATE. EDGES ARE SMOOTH, SQUARE AND STRAIGHT. 2" WIDE. LIES FLAT. RESISTS BENDING. LARGE, EASY-TO-READ NUMBERS. ENGLISH CALIBRATIONS READ 1/8 FROM ONE EDGE AND 1/16 FROM THE OTHER.

STOCK NO.	LENGTH
<b>LSS36090</b>	24"
<b>LSS36091</b>	36"
<b>LSS36092</b>	48"
<b>LSS36093</b>	60"
<b>LSS36094</b>	72"
<b>LSS36095</b>	96"

**ALUMINUM GIANT SQUARE  
DRYWALL LAYOUT SQUARE**



FLEXIBLE, ANODIZED ALLOY CONSTRUCTION. PARALLEL AND ACCURATE. EDGES ARE SMOOTH, SQUARE AND STRAIGHT. OFFSET HEAD ATTACHED WITH FOUR RIVETS TO ASSURE PERMANENT ACCURACY. LARGE, EASY-TO-READ NUMBERS. ENGLISH CALIBRATIONS READ 1/16 FROM EITHER SIDE OF THE BLADE, 1/8 ON THE HEAD.

STOCK NO.	LENGTH
<b>LSS36119</b>	48"

**ALUMINUM T-SQUARE**

FLEXIBLE, ANODIZED ALLOY CONSTRUCTION. PARALLEL AND ACCURATE. EDGES ARE SMOOTH, SQUARE AND STRAIGHT. 2" WIDE BLADE LIES FLAT AND RESISTS BENDING. LARGE EASY-TO-READ NUMBERS. ENGLISH CALIBRATIONS READ 1/8 FROM ONE EDGE, 1/16 FROM THE OTHER.



STOCK NO.	LENGTH
<b>LSS36136</b>	36"

**METER-MAN MEASURING WHEELS**

LIGHTWEIGHT DURABLE AND COMFORTABLE TO USE. WHEELS ARE MADE ENTIRELY OF CORROSION RESISTANT: ABS, PVC. 5 DIGIT COUNTER (10,000 FT).



STOCK NO. WHEEL DIAMETER

<b>KOMMK3112</b>	10"
------------------	-----



STOCK NO. WHEEL DIAMETER

<b>KOMMK4512</b>	14.3"
------------------	-------



STOCK NO. WHEEL DIAMETER

<b>KOMMK6012</b>	19"
------------------	-----



STOCK NO. WHEEL DIAMETER

<b>KOMMK7912</b>	25"
------------------	-----



**Young Bros.**  
Stamp Works Inc.  
Since 1904

**IDENTIFICATION TOOLS**

**STEEL MARKING STAMP SETS**



STEEL LETTERS AND FIGURES MADE OF EXTRA HEAVY, EXTRA LENGTH SHANK WITH SUPPORTING BEVELS. EACH STAMP HAS THREE DEEP GROOVES ACROSS THUMB SIDE OF STAMP FOR QUICK IDENTIFICATION, INDEX MARK AND POSITIVE GRIP.

**STANDARD METHODS OF DETERMINING CHARACTER SIZE**

Correct character size can be easily specified by using the following standardized guide. When re-ordering stamps, if in doubt as to size, send us an impression for identification.

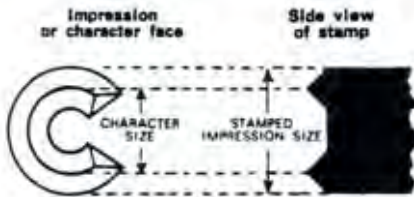

**SIZE CHART**

5	1/16"	5	1/4"
5	3/32"	5	5/16"
5	1/8"	5	3/8"
5	5/32"	5	1/2"
5	3/16"		

**LETTER SETS**  
27 CHARACTERS



STOCK NO.	STAMP SIZE	SQUARE SIZE
YB03273	1/8	5/16
YB05273	3/16	3/8
YB06273	1/4	7/16
YB08273	3/8	9/16
YB09273	1/2	3-3/4

INDIVIDUAL STAMPS AVAILABLE UPON REQUEST

**FIGURE SETS**  
9 CHARACTERS

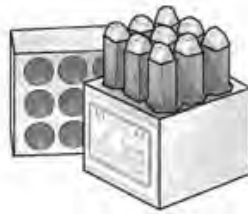

STOCK NO.	STAMP SIZE	SQUARE SIZE
YB03093	1/8	5/16
YB05093	3/16	3/8
YB06093	1/4	7/16
YB08093	3/8	9/16
YB09093	1/2	3-3/4

INDIVIDUAL STAMPS AVAILABLE UPON REQUEST

**ADJUSTABLE BRASS STENCILS**



**INTERLOCKING STENCIL SETS WITH GOTHIC-STYLE CHARACTERS**

**NUMBERS ONLY - SINGLE SETS**

15 PIECE SET AS FOLLOWS: 12345678900, 1-BEGINNER, 1-PLAIN ENDER, 1-DASH, 1-PERIOD.

STOCK NO.	SIZE
HS10008	1"
HS10009	1-1/2
HS10011	2"
HS10013	3"
HS10014	4"

**LETTERS ONLY - SINGLE SETS**

33 PIECE SET AS FOLLOWS: ABCDEFGHIJKLMNO PQRSTUWXYZ&, 1-BEGINNER, 1-PERIOD ENDER, 1-SPACER, 1-COMMA, 1-DASH, 1-PERIOD.

STOCK NO.	SIZE
HS10028	1"
HS10029	1-1/2
HS10031	2"
HS10033	3"
HS10034	4"

**LETTERS AND NUMBERS**

92 PIECE SET AS FOLLOWS: AAA BB CC DD EEEE FF GG HH III JJ KK LL MM NNN OOO PP Q RR SSS TT UU VV WW XX YY ZZ && 111 22 33 44 55 66 77 88 99 000, 1-BEGINNER, 1-PLAIN ENDER, 1-PERIOD ENDER, 3-SPACERS, 1-COMMA, 1-DASH, 2-PERIODS.

STOCK NO. HS10154 (4" SIZE)

**TAGS AND CHECK ACCESSORIES**



**ROUND BRASS TAGS** (BLANK, 3/16" HOLE, 18 GAUGE)

**SPLIT KEY RINGS**

**S-HOOKS** ZINC PLATED

**ROUND BRASS TAGS**

STOCK NO.	SIZE
HSCB1090	1-1/4
HSCB1094	1-3/8
HSCB1098	1-1/2

**SPLIT KEY RINGS**

STOCK NO.	SIZE (I.D.)
-----------	-------------

BM8K34	3/4
BM8K1	1"
BM8K114	1-1/4

**S-HOOKS**

STOCK NO.	SIZE WIRE DIA.	OVERALL LENGTH
GW52	.105	1-1/4
DA41705	5/32	1-1/2
DA41710	3/16	1-3/4

A COMPLETE SIZE RANGE WITH ADDITIONAL S-HOOKS CAN BE FOUND ELSEWHERE IN THIS CATALOG

**ADDITIONAL ITEMS AND SIZES AVAILABLE UPON REQUEST**

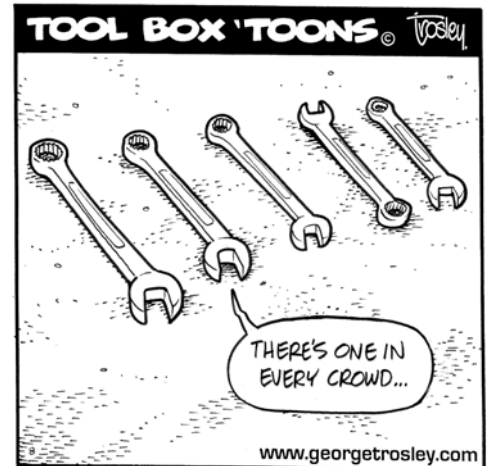

www.georgetrosley.com

**IDENTIFICATION TOOLS**

**TRANSFER PUNCHES**



PUNCHES ARE 4-7/8" LONG. BLACK OXIDE FINISH. USED FOR TRANSFERRING OF THREADED, DRILLED AND REAMED HOLES.

**28 PIECE SET**

28 PRECISION-MADE PUNCHES WITH INDEXED STAND. SIZES 3/32" TO 1/2" BY 1/64". PLUS HANDY 17/32" SIZE.

**STOCK NO. SPL317**

**INDIVIDUAL TRANSFER PUNCHES**

STOCK NO.	SIZE
SPL001	1/16
SPL003	3/32
SPL004	7/64
SPL005	1/8
SPL006	9/64
SPL007	5/32
SPL008	11/64
SPL009	3/16
SPL010	13/64
SPL011	7/32
SPL012	15/64
SPL013	1/4
SPL015	9/32
SPL016	19/64
SPL017	5/16
SPL019	11/32
SPL021	3/8
SPL022	25/64
SPL023	13/32
SPL025	7/16
SPL027	15/32
SPL029	1/2
SPL031	17/32
SPL033	9/16
SPL037	5/8
SPL041	11/16
SPL045	3/4
SPL053	7/8
SPL061	1"

**ADDITIONAL SIZES AND SETS AVAILABLE UPON REQUEST**

**HOLE CUTTING PUNCHES**



CUTTING APPLICATIONS: LEATHER, CLOTH, RUBBER, CORK, FELT, CANVAS, PLASTIC, GASKET MATERIAL, SOFT FIBROUS MATERIAL.

STOCK NO.	STD. ROUND SIZE (HOLE)
ADC01	1/4
ADC02	5/16
ADC03	3/8
ADC04	7/16
ADC05	1/2
ADC06	5/8
ADC07	3/4
ADC08	7/8
ADC09	1"
ADC10	1-1/8
ADC11	1-1/4
ADC12	1-3/8
ADC13	1-1/2
ADC14	1-5/8
ADC15	1-3/4
ADC16	1-7/8
ADC17	2"
ADC18	2-1/4
ADC19	2-1/2

**7 PIECE CUTTING PUNCH SET**



INCLUDES 1 EACH: 1/4, 3/8, 1/2, 5/8, 3/4, 7/8, 1". SET IS PACKED IN A WOODEN HOLDER.

**STOCK NO. ADC20**

**ADDITIONAL SIZES AND SETS AVAILABLE UPON REQUEST**

**CALL US FOR DETAILED PRICES AND SPECIFICATIONS**



ENGRAVES PERMANENTLY ON METAL, WOOD, PLASTIC, CERAMICS, AND MORE. PROTECT VALUABLES, DISCOURAGE THEFT. PERFECT FOR DOZENS OF HOBBIES AND CRAFTS.

**STOCK NO. DREM290**

**16-PIECE HOLLOW PUNCH TOOL KIT**



FOR CUTTING OUT WASHERS AND SEALING RINGS IN A MULTITUDE OF DIFFERENT MATERIALS, INCLUDING FOAM, CARDBOARD, LEATHER, RUBBER, FIBER, PLASTIC, GASKET MATERIAL AND LEAD. DUAL CUTTING HEADS CAN BE ARRANGED IN MANY COMBINATIONS TO CUT INSIDE AND OUTSIDE DIMENSIONS AT THE SAME TIME. 16-PIECE STANDARD SET WITH PUNCH SIZES 1/8" TO 1-3/16". HANDLE INCLUDED.

**STOCK NO. MAY66000**

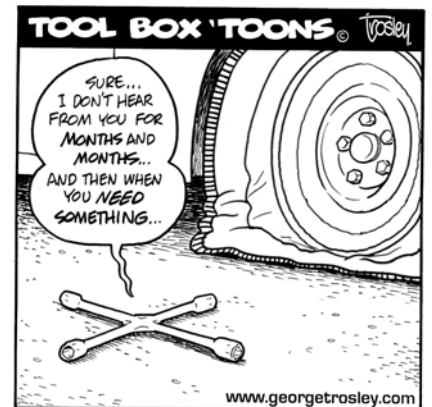

www.georgetrosley.com



**INDUSTRIAL MARKING PRODUCTS**



**ALL-PURPOSE COLD SURFACE MARKERS**



**MARKAL PAINTSTIK "B"**

REAL PAINT IN STICK FORM. DRIES OVERNIGHT. MARKS ON ANY SURFACE OR MATERIAL. WEATHER-RESISTANT AND FADE-RESISTANT. IDEAL FOR LAYOUT, COLOR CODING, INSPECTION OR FABRICATION. LEAD-FREE. MARKS ON OILY AND WET SURFACES. MARKING RANGE -50 TO 150°F. 11/16" DIAMETER. 12 OF ONE COLOR PER BOX, 144 PER CASE.

STOCK NO.	COLOR	STOCK NO.	COLOR
MA01	YELLOW	MA80226	GREEN
MA02	RED	MA80228	PURPLE
MA03	WHITE		
MA031	BLUE		

OTHER COLORS AVAILABLE PER REQUEST

**HOT SURFACE PAINTSTIK MARKER**



**MARKAL PAINTSTIK "H"**

HIGHLY VISIBLE MARKING FOR HOT SURFACES. MARKS HOT COILS, SLABS, BILLETS, BARS, INGOTS, ETC. MARKS WILL NOT RUN, CHAR, DISCOLOR, PEEL OR CRACK. LONG-LASTING, WEATHER-RESISTANT AND FADE-RESISTANT. MARKING RANGE 150 TO 1200°F. 144 PER CARTON.

STOCK NO.	COLOR	STOCK NO.	COLOR
MA27	WHITE	MA81022	RED
MA81025	BLUE		

**DURA-INK FELT TIP MARKERS**



**SHARPIE #15:** MARKER IDEAL FOR FINE LINE MARKING. EXTRA-STRONG TIP. SMEAR RESISTANT, WATER-RESISTANT AND FAST-DRYING. BLACK INK. OTHER COLORS AVAILABLE UPON REQUEST. 12 PER BOX.

STOCK NO. MA60



**DURA-INK #25:** BROAD TIP FOR BOLD MARKS. HEAVY-DUTY METAL BARREL. LARGE INK SUPPLY FOR GREATER MILEAGE. CHISEL TIP. BLACK INK. OTHER COLORS AVAILABLE UPON REQUEST. 12 PER BOX.

STOCK NO. MA17



**DURA-INK #200:** EXTRA-WIDE CHISEL TIP. HEAVY-DUTY METAL BARREL. LARGE INK SUPPLY FOR GREATER MILEAGE. INK FORMULATED FOR INDUSTRIAL STRENGTH USAGE. BLACK INK. OTHER COLORS AVAILABLE UPON REQUEST. 12 PER BOX.

STOCK NO. MA18

**BALL PAINT MARKERS**



1/8" BALL SIZE; 2 OZ. BOTTLE. FINE LINE MARKS WITH REAL PAINT THAT DRIES IN MINUTES. MARKS ARE WATER-RESISTANT AND WEATHER RESISTANT. TYPICAL USES: METAL PIPE, I-BEAMS, SHEET METAL, LUMBER AND PVC PIPE. DURABLE PLASTIC BOTTLE AND METAL BALL TIP. MARKING RANGE -50 TO 150°F.

STOCK NO. COLOR

MA25	WHITE
MA26	YELLOW

**FAST DRY MARKER**



DRIES IN 5 MINUTES. MARKS THROUGH OIL AND WATER FILM. IDEAL FOR MARKING IN FABRICATING SHOPS AND ASSEMBLY LINES WHERE IMMEDIATE HANDLING IS NECESSARY. MARKS ON METAL, WOOD, PLASTIC, RUBBER, GLASS, CARDBOARD AND PAPER. MARKING RANGE -50 TO 150°F. 12 PER BOX.

STOCK NO.	COLOR
MA15	YELLOW

OTHER COLORS AVAILABLE PER REQUEST

**CARPENTER PENCIL**



PREMIUM QUALITY. MARKS CLEAN, ACCURATE MARKS ON WOOD AND OTHER SURFACES. FLAT LEAD DESIGN FOR EASIER MARKING.

STOCK NO. MA65

**SOAPSTONE**



FOR THE TEMPORARY MARKING OF METAL SURFACES DURING FABRICATION JOBS.

STOCK NO. EW01	(5" FLAT)
STOCK NO. EW02	(1/4 x 5" ROUND)

**SOAPSTONE HOLDERS**



STOCK NO. EW03	(FLAT, W/ CLIP AND 1 STONE)
STOCK NO. EW04	(ROUND, W/ CLIP/ 1 STONE)

**SILVER STREAK MARKERS**



MARKS ON ANY METAL SURFACE AND IS RESISTANT TO TORCH FLAME. MARKS ON OILY, WET OR RUSTY METALS. WILL NOT SCRATCH OR ABRASE METAL SURFACES.

STOCK NO. MA96006

**SILVER STREAK REFILL PACK**

STOCK NO. MA96007 (6/PK)

**HEAT-TREATING AND ANNEALING MARKERS**



**MARKAL PAINTSTIK "M"**

MARKS WITHSTAND QUENCHING IN WATER OR OIL. FOR WELDS, INGOTS, CASTINGS AND FORGING. MARKS AT ROOM TEMPERATURE WITHSTANDS TO 1600°F.

STOCK NO.	COLOR
MA07	YELLOW
MA08	RED
MA10	BLACK
MA12	WHITE

**PRO-EX LUMBER CRAYONS**



FOR WET OR DRY SURFACES. MAKES WEATHER-RESISTANT AND FADE-RESISTANT MARKS. LONG-LASTING. LEAD-FREE. MARKS ON CONCRETE, WOOD, METAL, PLASTICS, PAPER, RUBBER, CARDBOARD AND CERAMICS. MARKING RANGE -50 TO 150°F. 12 OF ONE COLOR PER BOX, 144 PER CASE.

STOCK NO.	COLOR
MA19	YELLOW
MA20	RED

OTHER COLORS AVAILABLE UPON REQUEST

**THERMOMELT STIKS**



ACCURATE, FAST, LOW-COST METHOD FOR MEASURING SURFACE TEMPERATURES. ACCURATE TO PLUS OR MINUS 1% OF STATED TEMPERATURE. 4-1/2" STIK FEATURES STAINLESS STEEL HOLDER AND POCKET CLIP. IDEAL USE FOR TOOL AND DIE REPAIR, WELDING, TEMPERING AND FORGING.

STOCK NO.	TEMP.	STOCK NO.	TEMP.	STOCK NO.	TEMP.
MA295	200				
MA30	250	MA334	450	MA345	750
MA31	275	MA335	475	MA35	800
MA32	300	MA336	500	MA355	850
MA333	425	MA337	550	MA36	900
MA33	350	MA338	600	MA365	932
MA331	375	MA339	650	MA37	950
MA332	400	MA34	700	MA38	1000

OTHER TEMP. AVAILABLE UPON REQUEST

**RAILROAD CHALK**



IDEAL FOR MAKING TEMPORARY MARKS ON MOST SURFACES. 4" x 1" TAPERED SHAPE FOR BROAD MARKS. 144 PER CASE.

STOCK NO. MA80500	(WHITE)
STOCK NO. MA80501	(YELLOW)

**LAYOUT FLUIDS AND MARKERS**

**BRUSH-ON LAYOUT FLUIDS**



DYKEM STEEL BLUE DX-100 HELPS PREVENT METAL GLARE WHEN MARKING DIES AND TEMPLATES. DRY-TO-TOUCH IN TWO MINUTES. ALSO AVAILABLE IN DYKEM RED AND DYKEM WHITE.

STOCK NO.	COLOR	SIZE
DYK8B	BLUE	8 OZ. PLASTIC BOTTLE
DYK128BB	BLUE	GALLON
DYK8R	RED	8 OZ. PLASTIC BOTTLE
DYK8W	WHITE STAIN	" "

**PERMATEX PRUSSIAN BLUE**



AIDS PRECISION FITTING OF MACHINED SURFACES. LOCATES HIGH SPOTS ON BEARINGS, VALVES AND OTHER CLOSE-TO-TOLERANCE COMPONENTS. NON-DRYING. EASY CLEANUP. .75 FL OZ TUBE

STOCK NO. AP80038

ADDITIONAL PRODUCTS AVAILABLE UPON REQUEST

**SPRAY LAYOUT FLUIDS**



STOCK NO.	COLOR	SIZE
DYK16BA	BLUE	16 OZ. AEROSOL
DYK16RA	RED	16 OZ. AEROSOL
DYK16WA	WHITE STAIN	12 OZ. AEROSOL
16YSA	YELLOW STAIN	16 OZ. AEROSOL

**DYKEM REMOVER/THINNER**



FOR REMOVING AND THINNING DYKEM-BRAND MARKING FLUIDS. ALSO FOR CLEANING SURFACE PRIOR TO APPLICATION OF DYKEM PRODUCTS. ONE GALLON.

STOCK NO. DYK138G

**VALVE ACTION PAINT MARKERS**



PAINT FORMULATED FOR INDUSTRIAL AND FARM APPLICATIONS. DRIES IN MINUTES. WEATHER-RESISTANT MARKS. LEAD-FREE. IDEAL FOR MANY SURFACES, INCLUDING METAL, GLASS, WOOD, RUBBER, PLASTIC, CARDBOARD AND PAPER. MARKING RANGE -50 TO 150°F. 12 OF ONE COLOR TO A BOX. CAN BE PURCHASED INDIVIDUALLY ALSO.

STOCK NO.	COLOR
MX001	WHITE
MX002	YELLOW
MX003	BLACK
MX004	RED
MX005	GREEN
MX006	BLUE



MA275	WHITE
MA28	YELLOW

OTHER COLORS AVAILABLE UPON REQUEST

**PRO-LINE PAINT MARKERS**



PRO-LINE MICRO FROM MARKAL IS A LONG LASTING, EASY TO USE, LESS ODOR CAUSING TRUE FINELINE PRECISION PAINT MARKER. WITH ITS DURABLE, HIGH-STRENGTH, LIGHTWEIGHT BARREL FOR INDUSTRIAL USE MAKES IT VERSATILE AND IDEAL FOR METAL WHILE STILL BEING SUITABLE FOR WOOD, GLASS, PLASTIC, RUBBER AND MORE.

STOCK NO.	COLOR
MA96888	WHITE
MA96889	YELLOW
MA96890	BLACK
MA96891	RED

**DURA-BALL PAINT TUBE MARKER**



COLORS ARE LOW CHLORIDE SAFE FOR MARKING STAINLESS STEEL. MARKS ON ALL HARD SURFACES SUCH AS METAL, PLASTIC, GLASS AND WOOD. WON'T RUN ON VERTICAL OR OVERHEAD SURFACES. MARKING RANGE -50°F TO 150°F.

STOCK NO.	COLOR
MA96652	WHITE
-	YELLOW

**ADDITIONAL ITEMS AVAILABLE - CALL FOR DETAILS**



## MAINTENANCE AEROSOLS



### LUBRICANTS

#### WHITE LITHIUM



A HIGH-SOLIDS WHITE GREASE EXCELLENT FOR METAL-TO-METAL APPLICATIONS. LONG LASTING LUBRICATION. IDEAL FOR CHAINS, GEARS, DRIVES AND HINGES. EFFECTIVE FROM MINUS 20°F. TO 300°F.

STOCK NO. SO100

#### "RUST-BREAKER" PENETRANT



QUICKLY LOOSENS RUST WHILE PENETRATING GREASE AND DIRT. NON-STAINING. ALSO WORKS AS A CORROSION PREVENTATIVE. NON-FLAMMABLE.

STOCK NO. SO103

#### DRY LUBE MOLY SPRAY



EFFECTIVE LUBRICATION UNDER CONDITIONS OF HIGH PRESSURE AND HIGH TEMPERATURE (UP TO 600°F.). QUICK DRY, TIGHT ADHESION. PENETRATES PORES. IDEAL FOR ASSEMBLY, MAINTENANCE, INDUSTRIAL & AUTOMOTIVE GASKET COATING, AND FOUNDRIES.

STOCK NO. SO200

#### OPEN GEAR AND WIRE ROPE SPRAY



PENETRATES PORES OF GEAR TEETH AND WIRE ROPES THROUGH FOAMING ACTION. REQUIRES NO HEATING. WITHSTANDS EXTREME PRESSURE LOADS AND TEMPERATURES. DISPLACES WATER FOR RUST PROTECTION.

STOCK NO. SO201

#### OPEN CHAIN LIGHT OIL LUBRICANT



IDEAL FOR USE ON CHAIN DRIVE EQUIPMENT. PENETRATES AND PROTECTS. REDUCES FRICTION WEAR. MOLY ADDITIVE ENABLES MOISTURE DISPLACEMENT AND HELPS TO WITHSTAND EXTREME TEMPERATURE AND CLIMATE.

STOCK NO. SO202

### LUBRICANTS

#### DRY GRAPHITE SPRAY LUBRICANT



QUICK-DRY DARK GRAY FINISH. IDEAL WHERE GOOD ELECTRICAL CHARACTERISTICS AND POSITIVE LUBRICATION ARE REQUIRED. WILL WITHSTAND 850°F. FOR LIMITED PERIODS, 400°F. INDEFINITELY BASED UPON LOAD DEMANDS.

STOCK NO. SO204

#### CUTTING OIL SPRAY



LONGER TOOL LIFE WITH PENETRATING FOAMING ACTION. LUBRICATES AND COOLS CUTTING POINT AND ELIMINATES SCORING. CLINGS TO CURVED SURFACES. SPEEDS UP CUTTING, SAWING, DRILLING, TAPPING AND MILLING.

STOCK NO. SO208

#### BELT DRESSING



EFFECTIVELY INCREASES GRIPPING POWER UP TO 50%. PERFORMS WELL IN WET, OUTDOOR CONDITIONS. CAN BE APPLIED DIRECTLY ONTO BELTS WHILE RUNNING. WILL NOT GLAZE OR COLLECT DIRT AND DUST.

STOCK NO. SO607

#### ANTI-SEIZE SPRAY



CONTAINS NO SILICONE OR LEAD. NON-TOXIC. PROVIDES PROTECTION FROM MINUS 297°F. TO PLUS 2200°F. PREVENTS CORROSION, SEIZURE, GALLING AND GALVANIC PITTING. REDUCES FRICTION AND WEAR. IDEAL FOR SPROCKETS, CHAINS, VALVE ASSEMBLIES, BEARINGS, PISTONS, ETC.

STOCK NO. SO620

**STOP ON IN AND SEE HOW WE CAN MAKE A DIFFERENCE**

### LUBRICANTS

#### SYNTHETIC DRY LUBE



A PENETRANT, DEMOISTRANT AND RUST PREVENTATIVE. IDEAL FOR SHORT-TERM ITEMS TO BE STORED OR SHIPPED. USE ON AUTOMOTIVE AND AIRCRAFT PARTS, CASTINGS, LOCKS, MOLDS, THREADS, ENGINES, GEARS AND ELECTRICAL EQUIPMENT. EXCELLENT WATER DISPLACEMENT PROPERTIES.

STOCK NO. SO737

#### PDRP (WAXY FILM)



THIS FORMULA OFFERS LONG-TERM PROTECTION OF ALL METAL SURFACES. IDEAL FOR EXTERNAL SURFACES OF MACHINES, INTERNAL COMBUSTION ENGINES, FABRICATED PARTS AND OUTDOOR ELECTRIC SYSTEMS.

STOCK NO. SO710 (SPRAY)  
STOCK NO. SO71001 (GALLON)

#### TEFLON DRY LUBRICANT



COATS SURFACES WITH A CHEMICALLY INERT FILM. RESISTANT TO MOST CHEMICALS AND SOLVENTS. DRIES TO A WHITE FILM. WON'T REACT OR COMBINE WITH PROCESS MATERIALS. ALSO ACTS AS A SEALANT.

STOCK NO. SO708

#### PENETRANT/LUBRICANT/RUST PREVENTATIVE



711's ULTRA-THIN FILM PENETRATES AND RELEASES CORRODED PARTS. DISPLACES AND DISPELS WATER. IDEAL FOR ELECTRICAL DEVICES AND COMPONENTS, GEARS, PRODUCTION EQUIPMENT AND AUTOMOTIVE APPLICATIONS. DOES NOT CONTAIN SILICONE.

STOCK NO. SO711 (SPRAY)  
STOCK NO. SO71101 (GALLON)

NOT THE FASTEST HORSE CAN CATCH A WORD SPOKEN IN ANGER.

--CHINESE PROVERB



**MAINTENANCE AEROSOLS**



**DEGREASERS**

**NO-FLASH SAFETY SOLVENT**



20 OZ. SPRAY. NON-FLAMMABLE. PENETRATES INSTANTLY TO REMOVE DIRT, OIL, GREASE AND WAX. INCREASES LIFE OF ELECTRICAL COMPONENTS. USE ON ELECTRIC MOTORS, GENERATORS, AIR TOOLS, BRAKES AND CHAINS. CONTAINS NO TRICHLOROETHANE (OZONE SAFE).

**STOCK NO. SO20848**

**ENGINE DEGREASER**



BIODEGRADABLE. WATER SOLUBLE FORMULA WILL CLEAN ALL MECHANICAL ENGINES, TOOLS AND MACHINERY. FLUSH WITH WATER AFTER USE AND CONTAMINANTS ARE CARRIED AWAY. ALSO GOOD FOR GREASY CONCRETE FLOORS.

**STOCK NO. SO702**  
**STOCK NO. SO703** (20OZ SAFETY SOLVENT)

**HEAVY-DUTY PAINT AND GASKET REMOVER**



REMOVES ACRYLIC ENAMEL, VARNISH, EPOXY AND URETHANE FINISHES, SHELLAC, DECALS AND ACRYLIC LACQUER. CUTS THROUGH GASKET CEMENTS, SEALANTS AND ADHESIVES. WHEN BLISTERING ACTION IS COMPLETE RESIDUE CAN BE REMOVED WITH A FLEXIBLE PUTTY KNIFE.

**STOCK NO. SO615**

**HEAVY DUTY INDUSTRIAL SPRAY ADHESIVE**



CAN BE USED TO BOND PLASTIC, GLASS AND LAMINATES TO TABLES, CABINETS AND SHELVING. HEAVY DUTY SPRAY ADHESIVE HAS A VARIABLE VOLUME CONTROLLED, LACE SPRAY PATTERN FOR STRONGER BONDS AND SPRAY CONTROL. DOES NOT CONTAIN OZONE-DEPLETING CFCs. IDEAL FOR USE ON LAMINATES, PLASTIC, GLASS, CARDBOARD, METAL, CERAMICS, PARTICLE BOARD, PAPER AND WOOD.

**STOCK NO. SO9000**

**SUPER 77 ADHESIVE**



HIGH COVERAGE. FAST, AGGRESSIVE TACK; AND LONG-BONDING RANGE. SECURELY BONDS MOST LIGHT-WEIGHT MATERIALS. EXCELLENT FOR JOBS IN DISPLAYS AND FURNITURE, BONDING GASKETS IN WATER PUMPS, ATTACHES INSULATION TO SHEET METAL, ETC.

**STOCK NO. 3M77SUPER**

**COATINGS**

**VARNISH**



PENETRATES THOROUGHLY. QUICK-DRY FLEXIBLE FILM PROVIDING HIGH ADHESION, ARC RESISTANCE AND NON-TRACKING PROPERTIES. CAN BE USED AS A FINISHING VARNISH OR AS A PRIMER- BAKE OR AIR DRY. PROTECTS AGAINST OILS AND MOISTURE.

**STOCK NO. SO600** CLEAR INSULATING VARN.  
**STOCK NO. SO601** RED INSULATING VARNISH  
**STOCK NO. SO609** GREEN EPOXY INSULATING VARNISH

**ZINC COLD GALVANIZING COMPOUND**



ELECTROCHEMICALLY FUSES ZINC TO METAL SURFACES. CONFINES RUST TO EXPOSED AREA IF SCRATCHED- WILL NOT SPREAD. HIGHLY RESISTANT TO ALL FORMS OF CORROSION.

**STOCK NO. SO739** (SPRAY) BRITE ZINC  
**STOCK NO. SO740** (SPRAY)  
**STOCK NO. SO74101** (GALLON)

**WELDERS' ANTI-SPATTER**



**POWDER:** NON-FLAMMABLE. DRIES TO A WHITE FILM. PREVENTS SPATTER FROM STICKING TO METAL SURFACES. FILM EXPOSES CRACKS IN WELDS. EASILY REMOVED BY WIPING. DOES NOT CONTAIN SILICONE. SURFACE CAN BE PAINTED AFTER USE.

**STOCK NO. SO541**

**LIQUID:** NON-FLAMMABLE. KEEPS WELDING TIPS AND NOZZLES CLEAN. NON-GREASY. EFFECTIVE FOR ALL TYPES OF WELDING, ESPECIALLY MIG AND TIG TIPS. DOES NOT CONTAIN SILICONE. SURFACE CAN BE PAINTED AFTER USE.

**STOCK NO. SO542**

**CRYSTAL CLEAR ACRYLIC SPRAY**



GOES ON CLEAR AND STAYS CLEAR WITH NO RUNS OR DRIPS. A PERMANENT CORROSION-RESISTANT PROTECTIVE COATING. HELPS PREVENT TARNISH AND RUST. SEALS POROUS SURFACES. ADDS WATER RESISTANCE AND HELPS SHED DIRT.

**STOCK NO. SOK1301**

**INSECT REPELLENT II**



EPA APPROVED. REPELS MOSQUITOES, TICKS, CHIGGERS, DEER FLIES, STABLE FLIES, BLACK FLIES, GNATS AND FLEAS ON EXPOSED SKIN SURFACES.

**STOCK NO. SO856**

**"HIT SQUAD" INDUSTRIAL INSECTICIDE**



INDUSTRIAL-STRENGTH INSECTICIDE DESIGNED TO KILL COMMON INSECTS QUICKLY. WORKS ON HOUSE FLIES, MOSQUITOES, GNATS, WASPS, SMALL MOTHS, ANTS, ROACHES, WATER BUGS, SILVERFISH, ETC. EPA-REGISTERED. FOR INDOOR OUT DOOR USE. CAN BE USED ON BEDDING AND CARPETING.

**STOCK NO. SO859**

**"BLAST 'EM" WASP & HORNET KILLER**



FOR OUTDOOR USE ONLY. SHOOTS STREAM UP TO 15 FEET. KILLS WASPS, HORNETS, YELLOW JACKETS, FLIES, MOSQUITOES AND FLYING MOTHS. DOES NOT AFFECT MOST PLASTICS. MAY HARM DESIRABLE VEGETATION. NONETHELESS, BUGS HATE THIS STUFF.

**STOCK NO. SO20857**





## SILICONES

### ALL-PURPOSE SILICONE LUBRICANT



PENETRATES INTO HARD-TO-REACH AREAS. NON-STAINING AND NON-CORROSIVE. LONG LASTING. LUBRICATES FROM MINUS 50°F. TO PLUS 500°F. WILL NOT HARM PLASTICS. AN EXCELLENT RELEASE AGENT FOR RUBBER MOLDINGS. USE ON DOORS, HINGES, LOCKS, LEATHER, METAL, WINDOWS AND CONVEYORS.

STOCK NO. S0206

### HEAVY-DUTY SILICONE LUBRICANT



6.6% SILICONE FORMULA. STOPS SQUEAKS AND STICKING, ELIMINATES FRICTION, REPELS WATER AND PREVENTS FREEZING. DOES NOT HARDEN OR DEGRADE FROM -40°F TO 400°F. KEEPS RUBBER SOFT AND FLEXIBLE. APPLY TO WOOD, METAL, FABRIC, RUBBER OR LEATHER.

STOCK NO. S01324

### FOOD GRADE SILICONE LUBRICANT



USDA APPROVED. MEETS FDA REQUIREMENTS. LOW VISCOSITY AND GOOD LUBRICITY. NON-STAINING AND NON-CORROSIVE. MAY HARM CERTAIN PLASTICS. USE ON SLIDES, GUIDES, KNIVES, SLICERS, SAWS, GRINDERS, MIXERS, ALL FOOD AND DRUG PROCESSING EQUIPMENT. ALSO OVENS, BELTS AND CONVEYORS.

STOCK NO. S0510

## MOLD RELEASE

### PAINTABLE MOLD RELEASE



ODORLESS AND HEAT STABLE TO 550° F. IDEAL FOR ALL TYPES OF PLASTICS THAT NEED DECORATING AFTER MOLDING, PAINTING, ETC. COMPATIBLE WITH PLASTIC, RUBBER, WAX, MOST MOLDABLE RESINS AND ELASTOMERIC COMPOUNDS. RECOMMENDED FOR INJECTION MOLDING.

STOCK NO. S0309

### DRY FILM PTFE MOLD RELEASE



NON-SILICONE MOLD RELEASE. EXCEPTIONAL ANTI-STICK PROPERTIES. COMPATIBLE WITH MOST MOLDABLE RESINS. ALLOWS THE MOLDED PARTS TO BE PAINTED, PLATED OR OTHERWISE DECORATED. GOOD FOR HIGH OR LOW TEMP. MOLDS.

STOCK NO. S0311

## MAINTENANCE AEROSOLS

### MOLD CLEANER AND INHIBITOR



RECOMMENDED FOR ALL TYPES OF METAL MOLDS. SURFACE MOISTURE, DIRT OILS, RELEASE AGENT RESIDUES AND OTHER CONTAMINANTS ARE QUICKLY ELIMINATED WITHOUT THE NECESSITY OF REMOVING THE MOLD FROM THE MACHINE. THIS NON-ABRASIVE CLEANER LEAVES A FINE MICROSCOPIC INHIBITOR FOR SHORT TERM PROTECTION AGAINST CORROSION.

STOCK NO. S0351

## CONTACT CLEANERS

### ELECTRICAL CONTACT CLEANER



QUICKLY REMOVES DUST, GREASE AND OXIDATION. PROVIDES A LONG LASTING, NON-DRYING FILM WHICH LUBRICATES AND PROTECTS AGAINST CORROSION. RESTORES AND MAINTAINS ELECTRONIC EQUIPMENT. MAY BE HARMFUL TO CERTAIN PLASTICS AND RUBBER PARTS. NON-FLAMMABLE.

STOCK NO. S02001

### CONTACT & TUNER CLEANER



IDEAL FOR SENSITIVE EQUIPMENT AND PRECISION INSTRUMENTS. NON-CONDUCTIVE AND NON-FLAMMABLE, SO EQUIPMENT CAN BE CLEANED WHILE OPERATING. WILL NOT REACT WITH MOST PLASTICS. SAFE ON ALL METALS. USES: CAMERAS, VACUUM TUBE PARTS, RELAYS, SWITCHES, WATCHES AND LOCKS.

STOCK NO. S02204

### N.O.D. CONTACT CLEANER



A QUICK-DRY NON OZONE DEPLETING CLEANER THAT REMOVES OIL, GREASE AND DIRT FROM SENSITIVE EQUIPMENT AND PRECISION INSTRUMENTS. NON-CONDUCTIVE AND SAFE ON MOST PLASTICS. USE ON CAMERAS, WATCHES AND CLOCKS, ELECTRONIC GAMES, METERS, TYPE-WRITERS AND PRINTED CIRCUITS. CONTAINS NO CFC'S.

STOCK NO. S02302

SINCE GOD MADE US TO BE ORIGINALS, WHY STOOP TO BE A COPY?

--REV. BILLY GRAHAM



### ELECTRIC MOTOR DEGREASER & SAFETY SOLVENT



EFFECTIVE FOR USE IN MANY CLEANING AND DEGREASING OPERATIONS ON ELECTRICAL AND MACHINERY. PACKAGED WITH EXTENSION TUBE FOR PINPOINT APPLICATION. FOR USE ON: SWITCHES, TRANSMITTERS, MOLDS, CONTROLS, FUSE HOLDERS, RELAYS, TOOLING, MOTORS, ETC. MAY HARM CERTAIN PLASTICS, ELASTOMERS AND AIR DRY PAINTED SURFACES.

STOCK NO. S0703

### Q.A. INSPECTOR 2-PART CRACK DETECTING SYSTEM



2-PART QUALITY ASSURANCE SYSTEM DETECTS AND LOCATES CRACKS AND DEFECTS IN METALS AND NON-POROUS, NON-METAL PARTS. FOR TURBINE BLADES, MOLDS, STRUCTURAL BEAMS, PIPES, ETC. 9 OZ. EACH CAN.

744 **PENETRANT** SEEPS INTO CRACKS AND CREVICES.  
STOCK NO. S0744

745 **DEVELOPER** WILL REVEAL IN RED ANY FAULTS, CRACKS OR PORES.  
STOCK NO. S0745







**ACRYLIC ENAMEL SPRAY PAINTS**



STANDARD, INDOOR/OUTDOOR BASE. FAST DRY. MAXIMUM HIDING AND COVERAGE. FAN SPRAY VALVE.

STOCK NO.	COLOR
SO1006	ALLIS CHALMERS ORANGE
SO1009	FEDERAL HIGHWAY YELLOW
SO1101	CHERRY RED
SO1110	OSHA RED
SO1150	ZINGER PINK
SO1210	OSHA ORANGE
SO1285	CORDOVA BROWN
SO1305	LIGHT BEIGE
SO1310	OSHA YELLOW
SO1319	NEW CATERPILLAR YELLOW
SO1320	OLD CATERPILLAR YELLOW
SOK1809	SCHOOL BUS YELLOW
SOK1817	JOHN DEERE GREEN
SO1445	MEDIUM GREEN
SO1470	OSHA GREEN
SO1510	OSHA BLUE
SO1515	DARK BLUE
SO1540	LIGHT BLUE
SO1580	OSHA PURPLE
SO1615	MEDIUM GRAY
SO1645	LIGHT GRAY
SO1760	ALUMINUM
SOK1404	CHROME ALUMINUM
SO1765	GOLD
SO1770	OSHA GLOSS BLACK
SO1800	OSHA GLOSS WHITE
SO325	MACHINE DARK GRAY
SO326	MACHINE LIGHT GRAY
SO329	MACHINE BLUE GRAY
SO3720	FLAT WHITE
SO3725	SEMI-FLAT BLACK
SO3727	MAX FLAT BLACK

OTHER COLORS AVAILABLE UPON REQUEST

**PAINT-ALL ENAMELS**

FOR MAINTENANCE AND TOUCH-UP WORK. ALSO IDEAL FOR COLOR-CODING AND MARKING STEEL AND LUMBER.

STOCK NO.	COLOR
SO4101	FLAT WHITE
SO4102	FLAT BLACK
SO4103	RED
SO4104	YELLOW
SO4105	BLUE
SO4106	GREEN
SO4113	GLOSS WHITE
SO4114	GLOSS BLACK
SO4116	CHERRY RED

**STENCIL INKS**

WATERPROOF AND WEATHER-RESISTANT. DRIES INSTANTLY ON ALL SURFACES. WON'T SMEAR OR SMUDGE. ADHERES TO OILY AND HOT SURFACES. PERMANENT MARKS.

STOCK NO.	COLOR
SO3106	RED
SO3108	BLACK
SO3109	BLUE
SO3127	YELLOW

**INDUSTRIAL COATINGS**

**STENCIL KOVER**

THIS HIGH SOLIDS FORMULA COMPLETELY HIDES OLD STENCILS AND MARKINGS ON SHIPPING CONTAINERS MAKING THEM REUSABLE

STOCK NO. SO3119



**FLUORESCENT PAINTS**

COLORS GIVE 4 TIMES GREATER VISIBILITY THAN CONVENTIONAL PAINTS. TO ASSURE MAXIMUM BRIGHTNESS, USE SO3720 FLAT WHITE OR SO1800 GLOSS WHITE AS A BASE COAT BEFORE APPLYING.

STOCK NO. COLOR

SO1811	FLUOR. ORANGE
SO1812	FLUOR. RED
SOK3104	FLUOR. LEMON YELLOW
SO1815	FLUOR. GREEN



**UPSIDE-DOWN PAINTS & ACCESSORIES**

**MARKING PAINT**

SPRAYS IN INVERTED POSITION ONLY. NON-CLOGGING VALVE. WATER-BASE FORMULA FOR LESS PERMANENT MARKING APPLICATIONS, AND SOLVENT-BASE FORMULA FOR LONGER-TERM APPLICATIONS. HIGH VISIBILITY. FOR USE ON UTILITY LINES, EXCAVATION PROJECTS, ETC.

STOCK NO. COLOR

SO3610	SAFETY RED (WATER BASE)
SO3620	CAUTION BLUE (WATER BASE)
SO3621	UTILITY BLUE (SOLVENT BASE)
SO3620	SAFETY GREEN (WATER BASE)
SO3700	ALERT ORANGE (WATER BASE)
SO3550	ASPHALT BLACK (SOLVENT BASE)
SO3821	YELLOW TRAFFIC/UTILITY (SOLVENT)
SO3900	WHITE TRAFFIC/UTILITY (SOLVENT)
SO3801	YELLOW ( WATER BASE)
SO3901	WHITE ( WATER BASE)
SO3500	CLEAR (WATER BASE)



**HAND-HELD MARKING WAND.** EASY-TO-USE PISTOL GRIP. NO BACK STRAIN. DURABLE PLASTIC AND LIGHTWEIGHT STEEL. REMOVABLE SNAP-OUT WHEEL ON 34" MODEL.

STOCK NO. SOK7095 (12" LONG)  
 STOCK NO. SOK7096 (34" LONG)



**HAND-HELD STRIPING WAND.** PERFECT FOR EASY TOUCH-UPS OR STENCILING ON STRIPED SURFACES. DURABLE PLASTIC. 34" LONG. SNAP-OUT REMOVABLE WHEEL.

STOCK NO. SOK8360



**PAVEMENT STRIPING MACHINE**



FOUR-WHEEL WALK-BEHIND STRIPING MACHINE. USE FOR STRIPING LARGER AREAS AND WHERE MORE PRECISE STRIPING IS REQUIRED. HOLDS 12 SPARE CANS OF PAINT FOR CONVENIENCE.

STOCK NO. SOK8340

**STRIPING PAINT (SOLVENT BASE)**



FOR BRIGHT, CRISP LINES ON APPLICATIONS SUCH AS ATHLETIC FIELDS AND PARKING LOTS.

STOCK NO. SOK8300 (HIGHWAY WHITE)  
 STOCK NO. SOK8301 (HIGHWAY YELLOW)

**PRIMERS**



DRIES TO TOUCH IN 5 MINUTES. MAY RECOAT IN 1 HOUR. SEALS OUT MOISTURE. SANDABLE. PROVIDES A UNIFORM BASE FOR LACQUER OR ENAMEL FINISHES.

STOCK NO. DESCRIPTION

SOK1316	CHARCOAL BLACK
SO341	LIGHT GRAY
SO342	RED OXIDE
SO344	GREEN RUST INHIBITOR

**BLUE LAYOUT FLUID**



ADHERES TO METAL AND GLASS. FAST DRYING AND NON-FLAKING. HEAT RESISTANT AND NON-CORROSIVE. IDEAL FOR TOOL & DIE.

STOCK NO. SO603

**LAYOUT FLUID REMOVER**



LEAVES NO RESIDUE. ALSO EFFECTIVE AS A REMOVER OF LACQUER MATERIALS.

STOCK NO. SO606

**HI-HEAT SPRAY PAINT**



HEAT-RESISTANT SILICONE AND ACRYLIC RESINS. DRIES IN MINUTES. 600° CONSTANT OR 1000° INTERMITTENT.



STOCK NO. DESCRIPTION

SO324	HI-HEAT ALUMINUM
SO332	HI-HEAT BLACK



**INDUSTRIAL COATINGS**



**RUST-TOUGH ACRYLIC ENAMEL  
(20 OZ. AEROSOLS)**



RUST-TOUGH PREVENTIVE ENAMEL PROTECTS AGAINST RUST AND CORROSION ON IRON, STEEL AND ALL TYPES OF METAL. EXCELLENT PROTECTION. HIGH GLOSS FINISH. FAST-DRYING. EFFECTIVE ON PRIMED AND UNPRIMED SURFACES.

STOCK NO.	COLOR
SOR00799	GLOSS BLACK
SOR00789	FLAT BLACK
R00779	SEMI-GLOSS BLACK
SOR00929	GLOSS WHITE
R00909	FLAT WHITE
SOR00879	DARK MACHINERY GRAY
SOR00839	LIGHT MACHINERY GRAY
R00259	DEEP BLUE
SOR00719	TAN
SOR00759	CHESTNUT BROWN
SOR00349	BRIGHT GREEN
SOR00379	DARK GREEN
R00649	BRIGHT RED
R00489	EQUIPMENT YELLOW
R00569	EQUIPMENT ORANGE
SOR00159	ALUMINUM
SOR00249	OSHA BLUE
SOR00339	OSHA GREEN
SOR00439	OSHA YELLOW
SOR00559	OSHA ORANGE
SOR00639	OSHA RED

OTHER COLORS AVAILABLE UPON REQUEST

**TOOL-DIP COATING**



PLASTI-DIP FLEXIBLE COATING ADDS GRIP TO TOOL HANDLES. CUSHIONS AND INSULATES. COLOR CODES YARD TOOLS AND BENCH TOOLS. WON'T CHIP, CRACK OR PEEL. LASTS FOR YEARS. 14.5 OZ. CAN.

STOCK NO. PDI11601	(RED)
STOCK NO. PDI11602	(YELLOW)
STOCK NO. PDI11603	(BLACK)
STOCK NO. PDI11604	(BLUE)
STOCK NO. PDI11607	(WHITE)
STOCK NO. PDI10103	(BLACK - GALLON)

ADDITIONAL ITEMS AVAILABLE UPON REQUEST

**RUST-TOUGH ACRYLIC ENAMEL  
(GALLONS)**



STOCK NO.	COLOR
SOR00791	GLOSS BLACK
SOR00781	FLAT BLACK
SOR00771	SEMI-GLOSS BLACK
SOR00921	GLOSS WHITE
SOR00901	FLAT WHITE
SOR00871	DARK MACHINERY GRAY
SOR00831	LIGHT MACHINERY GRAY
R00251	DEEP BLUE
R00711	TAN
R00751	CHESTNUT BROWN
SOR00341	BRIGHT GREEN
SOR00371	DARK GREEN
R00641	BRIGHT RED
R00481	EQUIPMENT YELLOW
R00561	EQUIPMENT ORANGE
SOR00151	ALUMINUM
SOR00241	OSHA BLUE
SOR00331	OSHA GREEN
SOR00431	OSHA YELLOW
SOR00551	OSHA ORANGE
SOR00631	OSHA RED

**PAINT TIN CAN WITH LID**



STOCK NO.	SIZE
TC01	1 PINT
TC02	1 QUART
TC03	1 GALLON

**PAINT MIXER**



HEAVY DUTY MIXER CAN BE USED WITH ALL KINDS OF COMPOUNDS, PAINTS AND SEALERS. WELDED STEEL WITH HEXAGONAL SHAFT FOR POSITIVE CHUCK ENGAGEMENT.

STOCK NO.	SIZE
HY46560	3-1/4" DIA. X 3/8" X 16"
HY46565	4" DIA. X 1/2" X 23-1/2"

**PRIMERS**



HIGHLY-DURABLE CORROSION FIGHTING PRIMERS. DAMP PROOF. USE ON METAL AND WOOD.

**GRAY PRIMER**  
STOCK NO. SOR00829 (AEROSOL)  
STOCK NO. SOR00821 (GALLON)

**RED OXIDE PRIMER**  
STOCK NO. SOR00699 (AEROSOL)  
STOCK NO. SOR00691 (GALLON)

**AMBER SHELLAC**



SHELLAC'S FAST DRYING, HARD FINISH HAS PROVIDED YEARS OF PROTECTION TO ALL WOOD SURFACES WHILE IMPARTING A DEEP, RICH, WOOD-TONE FINISH. ALSO ACTS AS AN EXCELLENT PRE-PAINTING STAIN AND SEALER.

STOCK NO. AFS691730 (1 QUART)  
STOCK NO. AFS691965 (1 GALLON)

**LOCTITE EXTENDED RUST TREATMENT**



A ONE-STEP TREATMENT THAT GOES ON WHITE AND CONVERTS RUST TO A DURABLE, BLACK, METAL-PROTECTIVE COATING IN 10 MINUTES. WIRE BRUSH PARTS AND APPLY WITH BRUSH OR SPRAY. SURFACE RUST MUST BE PRESENT. EXTENDED RUST TREATMENT RESISTS TEMPERATURES TO 250° INTERMITTENT, 200° CONTINUOUS. EXTENDED RUST TREATMENT IS SATISFACTORY FOR EXTERIOR EXPOSURE WITHOUT A TOPCOAT IN MILD ENVIRONMENTS. TWO COATS MAXIMUM ARE RECOMMENDED. A 7 TO 14 DAY DRYING AND CURING TIME IS RECOMMENDED. FOR SEVERE ENVIRONMENTS, A SUITABLE TOPCOAT IS REQUIRED.

STOCK NO. LOC30539 (16 OZ AEROSOL)  
STOCK NO. LOC75430 (1 QUART)

**JANITORIAL CLEANING SUPPLIES**

**MAINTENANCE CLEANERS**  
**STAINLESS STEEL CLEANER**



WATER-BASE. CLEANS, BRIGHTENS AND PROTECTS ST. STEEL, CHROME, ALUMINUM, PORCELAIN AND CERAMIC TILE. EASILY REMOVES OIL-BASED STAINS AS WELL AS WATER SPOTS, SPILLS AND FOOD SOILS. NO GREASY FILM. CONTAINS NO HARMFUL PETROLEUM DISTILLATES. ACCEPTED BY USDA FOR USE IN FEDERALLY INSPECTED MEAT AND POULTRY PLANTS.

**STOCK NO. SO885 (17OZ. AEROSOL)**

**GENERAL PURPOSE CLEANER**



FAST AND EASY CLEAN-UP THROUGH FOAMING ACTION. DOES NOT STREAK. NON-STAINING. CONTAINS AMMONIA FOR EFFECTIVE GREASE CUTTING. USE ON GLASS, WINDOWS, MIRRORS, VINYL, PORCELAIN, FORMICA AND CHROME.

**STOCK NO. SO880 (19OZ. AEROSOL)**

**GLASS & WINDOW SPRAY CLEANER**



A FAST-ACTING FOAMING CLEANER THAT LEAVES GLASS SURFACES SPARKLING. STREAK PROOF FORMULA REMOVES SMOKE, GREASE AND GRIME. WIPE AWAY FINGERPRINTS, SMUDGES, DUST AND ROAD FILM. THIS PRODUCT IS ACCEPTABLE FOR USE IN INEDIBLE PRODUCT PROCESSING AREAS, NON-PROCESSING AREAS AND/OR EXTERIOR AREAS.

**STOCK NO. SO888 (18OZ. AEROSOL)**

**GLASS CLEANER**



THIS AMMONIA FREE CLEANER. GOOD ON WINDOWS, MIRRORS AND WINDSHIELDS FOR A NO FILM FINISH.

**STOCK NO. APSW50 (20 OZ. AEROSOL)**

**WINDOW WORKS-M**



GETS GLASS CRYSTAL CLEAR AND SQUEAKY CLEAN. CUTS THRU DIRT AND GRIME. LEAVES A CLEAR PROTECTIVE COATING. DUST RESISTANT. MINIMIZES WEAR AND SCRATCHING.

**STOCK NO. NIC5920 (1 GALLON)**

**MINT**  
**AIR FRESHENER - AEROSOLS**



DRY AIR MIST FRESHENER. FOR COMMERCIAL, INDUSTRIAL AND INSTITUTIONAL USE. MAY BE SAFELY SPRAYED ONTO FABRIC SURFACES.

**STOCK NO. SOC322 (11OZ AEROSOL)**

**APPLE**  
**AIR FRESHENER - AEROSOL**



DRY AIR MIST FRESHENER. FOR COMMERCIAL, INDUSTRIAL AND INSTITUTIONAL USE. MAY BE SAFELY SPRAYED ONTO FABRIC SURFACES.

**STOCK NO. SOC323 (11OZ AEROSOL)**

**OMNI-Q**  
**BATHROOM DISINFECTANT CLEANER**



NON-ACID QUATERNARY HOSPITAL TYPE DISINFECTANT BATHROOM AND ALL PURPOSE CLEANER AND DEODORIZER. EFFECTIVE AGAINST HIV-1 VIRUS, HERPES SIMPLEX TYPE 2, AND ATHLETES FOOT

**STOCK NO. SOC130 (32 OZ. SPRAY)**

**CLEAR LEMON PLUS**



HOSPITAL GRADE DISINFECTANT, EFFECTIVE AGAINST HIV. FOAMING CLEANER, DEODORIZER, AND FUNGICIDE. ELEMİNATES AND PREVENTS MOLD AND MILDEW. FRESH DEODORIZING LEMON FRAGRANCE.

**STOCK NO. SOC101 (18OZ AEROSOL)**

AS THE MAN AND WIFE RETURNED TO THEIR SEATS IN THE DARK AUDITORIUM, THE HUSBAND ASKED A FELLOW SEATED ON THE AISLE, "DID SOMEONE STEP ON YOUR FEET WHILE GOING OUT AT INTERMISSION?"

"YES, YOU DID," HE REPLIED, EXPECTING AN APOLOGY.

"OKAY HONEY," THE MAN SAID TO HIS WIFE, "THIS IS OUR ROW."

**CLEAR LEMON PLUS**  
**LEMON DISINFECTANT CLEANER**



QUAT-BASED FORMULA, HOSPITAL GRADE PLUS HIV CLAIM. SUPERIOR LEMON FRAGRANCE. EXCELLENT NEUTRAL CLEANER. 2 OZ. PER GALLON FOR GENERAL CLEANING AND DISINFECTING

**STOCK NO. SOC100 (1 GALLON)**

**POWER BOWL**  
**TOILET BOWL CLEANER**



9% HYDROCHLORIC ACID BOWL CLEANER. REMOVES LIME, HARD WATER DEPOSITS AND RUST STAINS. USE ON ACID RESISTANT SURFACES, TOILET BOWLS AND URINALS.

**STOCK NO. SOC155 (32 OZ./1 QUART)**

**BOWL BLAST**  
**TOILET BOWL CLEANER**



23% HYDROCHLORIC ACID, DISINFECTANT BOWL CLEANER. CLEANS, AND DEODORIZES. USE ON PROBLEM STAINS ON TOILET BOWL AND URINALS.

**STOCK NO. SOC151 (32OZ./1 QUART)**

**QUALITY  
PRODUCTS,  
FAIR  
AND  
COMPETITIVE  
PRICES,  
AND  
EXCELLENT  
SERVICE  
IS  
OUR  
REPUTATION**

**JANITORIAL CLEANING SUPPLIES**



**SIMPLE GREEN LIME SCALE REMOVER**

SPECIALLY FORMULATED TO EFFECTIVELY DISSOLVE AND REMOVE LIME SCALE, SOAP SCUM, AND MINERAL DEPOSITS FROM SINKS, TOILETS, TUBS, CERAMIC TILE, ETC. DEODORIZES AS IT CLEANS.

STOCK NO. **SGC50032** (32 OZ. )



**ULTRA PURPLE CLEAN**

HIGHLY CONCENTRATED MULTI-PURPOSE CLEANER. SPECIALLY FORMULATED TO BE USED IN HOT OR COLD WATER. BIODEGRADABLE AND PHOSPHATE-FREE.

STOCK NO. **APPC32** (32OZ. SPRAY)



**MAINTENANCE POWER HEAVY DUTY INDUSTRIAL CLEANER/DEGREASER**

HIGH PERFORMANCE CLEANER/DEGREASER. REMOVES HEAVY GREASE AND SOILS. EFFECTIVE FOR USE IN PRESSURE WASHERS AND STEAMERS. USDA AUTHORIZED.

STOCK NO. **SOC001** (1 GALLON)  
STOCK NO. **SOC002** (5 GALLON)

**PRESOLVE CLEANER/DEGREASER**



OZONE SAFE, NATURAL BASED SOLVENT. NO RINSING OR RESIDUE. CLEANS ON CONTACT. NON-CONDUCTIVE. SAFE ON METALS AND MOST PLASTICS.

STOCK NO. **LPS01420** (15OZ. AEROSOL)



**MULTI SURFACE CLEANER**

READY-TO-USE, POWERFUL ALL PURPOSE CLEANER. EFFECTIVE ON A WIDE VARIETY OF SOILS AND GREASE. RECOMMENDED FOR ALL WASHABLE SURFACES. USDA AUTHORIZED.

STOCK NO. **SOC175** (32OZ. SPRAY)

**NEUTRA FORCE**



ALL PURPOSE NEUTRAL pH CLEANER/DEGREASER. ENVIRONMENTALLY FRIENDLY. CONTAINS NO CAUSTICS, ACIDS, BUTYLS OR OTHER HARSH CHEMICALS. CONTAINS MAL ODOR COUNTERACTANTS. USDA AUTHORIZED.

STOCK NO. **SOC019** (1 GALLON)  
STOCK NO. **SOC018** (5 GALLON)



**CITRUS CLEANER DEGREASER**

A HEAVY DUTY DEGREASER AND GRAFFITI REMOVER. A NON-CHLORINATED FORMULA HAS THE CLEANING POWER OF SOLVENTS TO REMOVE GRIME, DIRT GREASE AND OIL. AN OUTSTANDING BIODEGRADABLE DEGREASER FOR USE IN GENERAL MAINTENANCE, PUBLIC BUILDINGS, TRANSIT SYSTEMS, RESTROOMS, LOCKER ROOMS AND SCHOOLS. LEAVES A REFRESHING SCENT.

STOCK NO. **S0757** (16OZ. AEROSOL)



**MAGNUM GREEN CLEANER**

READY-TO-USE ALL PURPOSE POWER CLEANER. ENVIRONMENTALLY RESPONSIBLE FORMULA WITH D'LIMONENE AND WATER SOLUBLE SOLVENTS. FOR REMOVING MOST DIFFICULT SOILS FROM NON-POROUS SURFACES USDA AUTHORIZED.

STOCK NO. **SOC030** (32 OZ. SPRAY)

**POWER WASHER CLEANER/DEGREASER**



LOW FOAMING, POWERFUL NEUTRAL pH DEGREASER. ENVIRONMENTALLY FRIENDLY, NON-CAUSTIC, NON-TOXIC FORMULA. DESIGNED FOR HIGH PRESSURE WASHERS AND STEAMERS. USDA AUTHORIZED

STOCK NO. **SOC050** (1 GALLON)  
STOCK NO. **SOC049** (5 GALLON)

**"BLASTER" DEGREASERS**



FAST-ACTING, PENETRATING CITRUS DEGREASER THAT LEAVES NO RESIDUE AND IS IDEAL FOR HEAVY-DUTY MAINTENANCE (FLOORS, ENGINES, METAL PARTS). WATER-BASED DEGREASER TAKES ON TOUGH AUTOMOTIVE APPLICATIONS BY REMOVING HEAVY GREASE AND OILS, AND IS ENVIRONMENTALLY SAFE. BOTH ARE SUPER CONCENTRATED.



**CITRUS DEGREASER**

STOCK NO. **WES16CBD** (12 OZ. SPRAY)

**AQUEOUS DEGREASER**

STOCK NO. **WESABD32** (32 OZ. SPRAY)  
STOCK NO. **WESABD128** (1GALLON)



**AQUA ORANGE DEGREASER**

WATER-BASED D'LIMONENE CLEANER/DEGREASER. POWERFUL DEGREASER WITH A PLEASANT ORANGE FRAGRANCE. CONTAINS NO CAUSTICS, ACIDS OR HARSH CHEMICALS.

STOCK NO. **SOC024** (32 OZ. SPRAY)  
STOCK NO. **SOC025** (1 GALLON)

**3-IN-ONE PROFESSIONAL**



HEAVY-DUTY CLEANER DEGREASER. QUICKLY REMOVES GREASE, OIL, DIRT AND GRIME FROM ENGINES, LAWNMOWERS, CHAINSAWS, HEAVY EQUIPMENT AND MORE. CITRUS FOAMING ACTION FOR EXTRA CLEANING POWER.

STOCK NO. **WD10148** (18OZ SPRAY)

**ORANGE KUTT CITRUS CLEANER/DEGREASER**



NOT ONLY CLEANS, AND ELIMINATES FOUL ODORS, BUT DEODORIZES. ENVIRONMENTALLY SAFE, WILL BREAK DOWN IN SEWAGE SYSTEMS. NO HARSH SOLVENTS, ALKALIES OR FUMES. SAFE ON SKIN AND ALL SURFACES WHEN DILUTED. CLEAR, ORANGE COLOR WITH ORANGE SCENT.

STOCK NO. **DM004** (1 GALLON)  
STOCK NO. **DM0041** (5 GALLON)

**JANITORIAL CLEANING SUPPLIES**

**MULTI-SPOT CARPET SPOT REMOVER**



READY-TO-USE, MULTI-USE, HEAVY DUTY SPOT REMOVER. BREAKS DOWN A WIDE RANGE OF SOILS AND SPOTS. REMOVES MANY GREASE, LIPSTICK, FOOD AND OTHER STAINS.

STOCK NO. **SOC290** (32 OZ. SPRAY)

**NEUTRA POWER  
NO-RINSE FLOOR CLEANER**



CITRUS SCENTED, NEUTRAL ALL PURPOSE CLEANER. USE FOR CLEANING FINISHED FLOORS IN DAMP MOP OPERATIONS OR IN AUTOMATIC SCRUBBER. REQUIRES NO RINSING.

STOCK NO. **SOC220** (1 GALLON)

**MOP'N MELT  
FLOOR STRIPPER**



OUR MOST POPULAR HEAVY DUTY FLOOR STRIPPER. LIQUIFIES THE MOST DIFFICULT-TO-REMOVE FLOOR FINISHES. EFFECTIVE WITH MOP-ON OR ROTARY MACHINE OPERATIONS.

STOCK NO. **SOC240** (1 GALLON)

**DIAMOND SHIELD SEALER  
INDUSTRIAL POWER FLOOR SEALER**



25% SOLIDS SEALER COMBINING WATER-BASED ACRYLICS AND URETHANES. USE FOR EXTRA DURABILITY, ABRASION AND CHEMICAL RESISTANCE REQUIREMENTS ON CONCRETE, QUARRY TILE AND TERRAZZO. NO ETCHING NECESSARY.

STOCK NO. **SOC260** (1 GALLON)  
 STOCK NO. **SOC261** (5 GALLON)

**VALUE SHIELD  
RESILIENT FLOOR FINISH**



18% SOLIDS ACRYLIC SEALER/ FINISH. DETERGENT AND SLIP RESISTANT PERFORMANCE. FOR USE ON ALL RESILIENT FLOOR SURFACES. ECONOMICALLY PRICED.

STOCK NO. **SOC210** (1 GALLON)

**DUST-AID  
CLOTH & MOP TREATMENT - AEROSOL**



WATER-BASED DUST MOP & CLOTH TREATMENT. PREVENTS DUST FROM SCATTERING. USE ON AIR CONDITIONING FILTERS. PREVENTS DUST AND POLLEN FROM ENTERING ROOM.

STOCK NO. **SOC330** (18OZ. AEROSOL)

**PINE SOL**



STOCK NO. **JAN849** (28 OZ)

**PLEDGE**



STOCK NO. **JAN850** (18 OZ)

**COMET**



STOCK NO. **JAN851** (21 OZ)

**MURPHY'S OIL SOAP**



STOCK NO. **JAN855** (16 OZ)

**BLEACH**



STOCK NO. **JAN872**  
(1 GALLON)

**LYSOL**



STOCK NO. **JAN902** (19 OZ)



**YOUR ONE STOP SOURCE FOR  
INDUSTRIAL SUPPLIES**

### SIMPLE GREEN

#### SIMPLE GREEN



CONCENTRATED CLEANER. NON-TOXIC AND BIODEGRADABLE. NON-ABRASIVE AND NON-FLAMMABLE. A4, A8, AND B2 USDA RATINGS. PRODUCT APPLICATIONS: BUILDING AND GROUNDS MAINTENANCE. JANITORIAL CLEANING: FLOORS, WALLS, COUNTERS, DOORS, CONCRETE, TILE, STAINLESS STEEL. SURFACE PAINT PREP. MANUFACTURING AND MRO CLEANING. CLEAN AND DEODORIZE GREASE FILTERS AND TRAPS.

**STOCK NO. SIZE**

- SGC13012** 24 OZ
- SGC13005** 1 GAL
- SGC13006** 5 GAL

#### CRYSTAL SIMPLE GREEN



NON-TOXIC AND BIODEGRADABLE. INDUSTRIAL FORMULATION. NO COLOR AND NO ADDED SCENT. NON-FLAMMABLE. A4 AND A8 USDA RATINGS. EQUIPMENT AND MACHINERY DEGREASING. FOOD PROCESSING AND HANDLING FACILITIES. JANITORIAL CLEANING: FLOORS, WALLS, COUNTERS, DOORS, CONCRETE, TILE, STAINLESS STEEL. CLEAN AND DEODORIZE GREASE FILTERS AND TRAPS.

**STOCK NO. SIZE**

- SGC19024** 24 OZ
- SGC19128** 1 GAL
- SGC19005** 5 GAL

#### EXTREME SIMPLE GREEN



NON-TOXIC AND BIODEGRADABLE. NON-ABRASIVE AND NON-FLAMMABLE. NON-CORROSIVE. RESIDUE-FREE RINSING. PRODUCT APPLICATIONS: ENGINE, AIRCRAFT AND VEHICLES. METALS, PLASTICS, HIGH-TECH ALLOYS, PART WASHING. JANITORIAL CLEANING: FLOORS, WALLS, COUNTERS, DOORS, CONCRETE, TILE, STAINLESS STEEL. HEAVY-DUTY CLEANER AND DEGREASER.

**STOCK NO. SIZE**

- SGC13412** 32 OZ
- SGC13406** 1 GAL
- SGC13405** 5 GAL

#### FOAMING CRYSTAL SIMPLE GREEN



SPECIALIZED FOAMING FORMULA, MADE WITH CRYSTAL SIMPLE GREEN. CLINGING AND PENETRATING FOAM CLEANS HARD TO REACH AREAS. NON-TOXIC AND BIODEGRADABLE. NON-CORROSIVE FORMULA IS SAFE ON METALS, FINISHES, PLASTIC AND RUBBER. RESIDUE-FREE RINSING. NON-FLAMMABLE. NON-ABRASIVE. QUICK, EASY AND CONVENIENT.

**STOCK NO. SIZE**

- SGC19024** 20 OZ (SPRAY)

#### SIMPLE GREEN d PRO 3 DISINFECTANT



ONE STEP GERMICIDE, VIRUCIDE, CLEANER AND DEODORIZER. HOSPITAL GRADE DISINFECTANT KILLS STAPH, SALMONELLS, PSEUDOMONAS, HIV-1, AND MORE. FRESH HERBAL-PINE SCENT. CLEANS, DISINFECTS AND DEODORIZES HOSPITALS, PRISON, SCHOOLS, PUBLIC AREAS, BATHROOMS AND MORE.

**STOCK NO. SIZE**

- SGC30332** 32 OZ
- SGC30301** 1 GAL

#### SIMPLE GREEN d PRO 5 DISINFECTANT



ONE STEP DISINFECTANT, VIRUCIDE, FUNGICIDE, MILDEWSTAT, CLEANER AND SANITIZER. BLOOD-BORNE PATHOGEN COMPLIANT DISINFECTANT KILLS MRSA, HIV-A, HEP B AND C, AVIAN INFLUENZA AND MORE. NO COLOR OR FRAGRANCE, SUITABLE FOR FOOD PROCESSING AND FACILITIES. SANITIZING DILUTION. HOSPITALS, HEALTH CLUBS, CAFETERIAS, CLINICS, SCHOOLS, PRISONS, ANIMAL AREAS AND MORE.

**STOCK NO. SIZE**

- SGC30532** 32 OZ
- SGC30501** 1 GAL

#### LIME SCALE REMOVER



DISSOLVES SOAP SCUM, HARD WATER STAINS AND MINERAL DEPOSITS. NON-ABRASIVE AND NON-FLAMMABLE. NON-FUMING, BUFFERED ACID. NO BLEACH, AMMONIA OR PHOSPHOROUS. DESCALE: HVAC COMPONENTS, PIPES, SPRINKLERS, HUMIDIFIERS, SPAS, SPRAY RACK SYSTEMS.

REMOVES SOAP SCUM FROM BATHROOM AND KITCHEN FIXTURES AND SURFACES.

**STOCK NO. SIZE**

- SGC50032** 32 OZ

**DRAIN CLEANERS & INDUSTRIAL CHEMICAL MAINTENANCE PRODUCTS**

**DRAIN OPENERS**



**CLOBBER** FROM *HERCULES* IS A HIGHLY CONCENTRATED SULFURIC ACID DRAIN OPENER THAT TESTED BEST AMONG LEADING BRANDS AGAINST PIPE CORROSION. FASTEST METHOD FOR CLEARING WASTE LINE STOPPAGES.

STOCK NO. **HER20205** (1 QUART)  
STOCK NO. **HER20211** (2 QUART)

**DRAIN CLEANER**



LIGHT-DUTY PRODUCT FOR DRAINS TO 1-1/2". COMFORTABLE HAND GRIP EASES EFFORT. 1/4" x 25' HOLLOW CORE CABLE HELD SECURELY BY A STEEL COLLAR AND THUMB SCREW.

STOCK NO. **RID59807**

**SIZZLE LIME REMOVER**



HIGHLY CONCENTRATED HYDROCHLORIC ACID WITH SPECIAL ANTI-CORROSION INHIBITOR AND ANTI-FOAM AGENT. REMOVES LIME, RUST, SCALE, CONCRETE, MINERALS AND SOLUBLE SALT. WORKS FOR WATER SYSTEMS, WASTE LINES, AIR CONDITIONING EQUIPMENT, HUMIDIFIERS, HEATING AND PROCESSING. POUR SPOUT AND pH TEST KIT INCLUDED.

STOCK NO. **HER20310** (GALLON)

**MURIATIC ACID**



STOCK NO. **AFS670110** (1 GAL)

**PAINT THINNER**



STOCK NO. **MD45562** (1 GAL)

CALL FOR COMPLETE SPECIFICATIONS  
AND PRICES

**LACQUER THINNER**



STOCK NO. **AFS658125** (1 GAL)  
STOCK NO. **AFS658360** (5 GAL)

**DENATURED ALCOHOL**



STOCK NO. **AFS10902** (5 GAL)

**XYLENE**



STOCK NO. **AFS12203** (1 GAL)  
STOCK NO. **AFS12204** (5 GAL)

**ACETONE**



STOCK NO. **AFS12403** (1 GAL)

**STODDARD SOLVENT**



FOR PARTS WASHERS.

STOCK NO. **GU03** SIZE **5 GALLON**

**"BLASTER"  
PARTS WASHER SOLVENT**



CUTS THROUGH CUTTING OIL, WATERSOLUBLE OIL, MOTOR OILS & GREASE. SAFE TO USE ON ALL METALS, MOST PLASTICS & PAINTED SURFACES. WORKS BETTER THAN MINERAL SPIRITS. LEAVES PARTS FILM FREE.

STOCK NO. **WES5PWS** SIZE **5 GALLON**

**ICE MELTERS**

**CALCIUM CHLORIDE PELLETS**



MELTS ICE FASTER. DOESN'T CHEMICALLY HARM CONCRETE NOR DOES IT LEAVE A POWDERY RESIDUE. IT IS EASIER ON TURF GRASS. WORKS AT COLDER TEMPERATURES DOWN TO -25°F.

STOCK NO. **IM05** (50# BAG)

**CALCIUM CHLORIDE FLAKES**



MULTI-PURPOSE AND MULTI-SEASONAL. USED OFTEN FOR DUST CONTROL AND IN BEDS OF TRUCKS TO PREVENT LOAD FREEZING.

STOCK NO. **IM06** (50 LB. BAG)

**ROCK SALT ICE MELTER**



STOCK NO. **IM01** (50# BAG)

**INDUSTRIAL ICE MELT**



ENHANCED WITH CALCIUM CHLORIDE MELTING POWER. SAFE ON DRIVEWAYS, SIDEWALKS, STEPS AND THE ENVIRONMENT WHEN USED CORRECTLY. DOES NOT TRACK, ODORLESS AND COLORLESS. EFFECTIVE TO -15°F TEMPERATURE.

STOCK NO. **IM10** (50 LB. BAG)

**SPREADERS**

IDEAL FOR APPLYING PLANT FOODS AND FERTILIZERS, GRANULAR BAITS, INSECTICIDES, AND HERBICIDES TO LARGE AREAS. APPLY GRANULAR ICE MELTING PRODUCTS SUCH AS ROCK SALT, CALCIUM CHLORIDE, AND SIMILAR PRODUCTS.



STOCK NO. **IM51**

STOCK NO. **IM50**



### SOLDER PRODUCTS



#### NO. 5 SOLDER PASTE FLUX



CLEANS AND FLUXES AT THE SAME TIME. FORMULATED WITH A HIGH FLASH POINT, AND STAYS IN SUSPENSION UNDER NORMAL WEATHER CONDITIONS AND TEMPERATURES. BLENDED TO CLEAN SURFACE OXIDATION. PROVIDES SUPERIOR WETTING PROPERTIES WHICH ALLOW BETTER SOLDER FLOW. EFFECTIVE ON ALL METALS EXCEPT ALUMINUM AND STAINLESS STEEL.

STOCK NO. OAT30011 (1.7 OZ.)  
STOCK NO. OAT30041 (1 LB.)

#### #11 SOLDER LIQUID FLUX



FORMULATED WITH A STRONG CLEANING AGENT, #11 LIQUID FLUX INSURES A FAST AND EFFECTIVE SOLDERING OPERATION. NO NEED TO WASTE TIME CLEANING OXIDIZED COPPER TUBING. MAY BE USED WITH ALL SOFT SOLDERS AND IS PACKAGED IN A NON-BREAKABLE PLASTIC BOTTLE WITH AN EASY-TO-USE SPRAY TIP.

STOCK NO. OAT30106

#### SOLID WIRE SOLDER



TO BE USED WITH EXTERNAL FLUX. USED FOR TIN PLATE WORK, SHEET METAL SEEMING AND HOT WATER HEATING LINES.

STOCK NO.	SIZE	DESCRIPTION	GAUGE
OAT20019	1 LB.	50/50	.125
OAT21018	1 LB.	40/60	.125
OAT22017	1 LB.	95/5	.125

#### ACID CORE SOLDER



ACID FLUX IS CONTAINED IN THE WIRE CORE. NO EXTERNAL FLUX IS NECESSARY. GENERAL PURPOSE SOLDER FOR SHEET METAL WORK, AUTO RADIATOR REPAIR, STEEL GUTTERS, ETC. NOT FOR USE IN ELECTRICAL APPLICATIONS.

STOCK NO.	SIZE	DESCRIPTION	GAUGE
OAT21115	1 LB.	40/60	.125

#### ROSIN CORE SOLDER



ROSIN FLUX IS CONTAINED IN THE WIRE CORE. DESIGNED FOR ELECTRICAL-ELECTRONIC WORK, FLUX RESIDUE IS NON-CORROSIVE AND NON-CONDUCTIVE. USE ON WIRING IN STEREOS, MOTORS, APPLIANCES, AUTO BATTERIES, CABLES, ETC.

STOCK NO.	SIZE	DESCRIPTION	GAUGE
OAT21212	1 LB.	40/60	.125
OAT53016	4 OZ.	40/60	.062
WELWS6016	1LB.	40/60	.062

#### ACID BRUSHES



ACID BRUSH FOR APPLYING ACID SOLDER. TIN FERRULE 5" LONG. HORSEHAIR FILL.

STOCK NO.	WIDTH INCHES	FERRULE DIA./INCHES	TRIM INCHES
RIM7420	5/16	3/16	3/4
WE44089	3/8	1/4	3/4
WE44090	1/2	5/16	3/4
MAGNOLIA3A	5/8	3/8	3/4

#### WIRE SCRATCH BRUSH



#60 STAINLESS STEEL. BENT HANDLE. TOOTHBRUSH STYLE. 8" OVERALL LENGTH; BRUSH PART 1-3/8"; TRIM LENGTH 1/2".

STOCK NO. LFT20060

#### LA-CO BLOC-IT HEAT ABSORBING PASTE

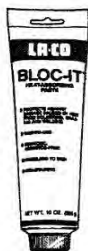

EFFECTIVELY ABSORBS SURFACE HEAT. PROTECTS ADJOINING SURFACES. NON-TOXIC. TYPICAL USES: PROTECTS RUBBER AND PLASTIC COMPONENTS IN VALVES DURING SOLDERING, PROTECTS PAINTED OR FINISHED SURFACES FROM ADJACENT SOLDERING, BRAZING OR WELDING.

STOCK NO. MA63 (10 OZ. TUBE)  
STOCK NO. MA11503 (4 LB.)

#### PLASTIC PIPE CEMENT



ALL PURPOSE CEMENT RECOMMENDED FOR ABS, PVC, AND CPVC PIPE AND FITTINGS. CLEAR, HEAVY-BODIED CEMENT FOR FITTINGS UP TO 12" IN DIAMETER. FOR ALL PIPE SCHEDULES, POTABLE WATER PRESSURE PIPES, GAS, CONDUIT, DRAIN WASTE AND VENT PIPE. HELPS FILL GAPS IN LARGER DIAMETER PIPE AND LOOSE FITTING JOINTS. APPLY AT TEMPERATURES 40°F. TO 100°F. 16 OZ.

STOCK NO. OAT30834

#### PLASTIC PIPE CLEANER



ALL PURPOSE CLEANER RECOMMENDED FOR ABS, PVC, AND CPVC PIPE AND FITTINGS, ALL SCHEDULES AND ALL DIAMETERS. A FAST-ACTING CLEANER TO REMOVE SURFACE DIRT, GREASE AND GRIME. FLOWS FREELY AND EVAPORATES QUICKLY. CLEAR CLEANER DOES NOT PENETRATE PIPE SURFACE. APPLY AT TEMPERATURES 40°F. TO 100°F. 16 OZ.

STOCK NO. OAT30795

**OUR WELL-STOCKED  
INVENTORY  
CAN SUIT  
ALMOST ANY  
APPLICATION!  
IF YOU DO NOT SEE  
THE ITEM YOU NEED,  
PLEASE LET US KNOW.  
WE'LL DO  
OUR VERY BEST TO  
LOCATE  
AND  
ACQUIRE  
THE ITEM FOR YOU!**

**ADDITIONAL ITEMS AVAILABLE  
UPON REQUEST**



PIPE THREAD SEALANTS & RELATED PRODUCTS

PIPE JOINT COMPOUND



A FAST SET NON-HARDENING PASTE WHICH LUBRICATES AND SEALS THREADED JOINTS. NON-TOXIC AND MAY BE USED ON WATER, NATURAL GAS, STEAM AND AIR LINES. PERFECT FOR APPLYING GASKETS TO FLANGES. PACKAGED WITH BRUSH TOP APPLICATOR. ALSO KNOWN AS PIPE DOPE. 16. OZ.

STOCK NO. OAT31228

PIPE JOINT COMPOUND STICK



PIPETITE-STIK FOR USE WITH WATER, STEAM, AIR, NATURAL GAS AND LP GAS PIPE THREADS. NON-TOXIC, LEAD-FREE. SEALING TEMPERATURE UP TO 350°F.

STOCK NO. MA56

TEFLON TAPE



SLIC-TITE TAPE FROM LACO IS A HEAVY-DUTY, PREMIUM GRADE PRODUCT. HIGH DENSITY. PROVIDES A HIGHLY RESISTANT SEAL ON PIPE THREADS. SUITABLE FOR USE WITH SOLVENTS, OXYGEN, CHEMICALS AND ON FOOD LINES. SEALING RANGE -450°F. TO 550°F.

STOCK NO. MA50 (1/2" x 600")  
STOCK NO. MA51 (1/2" x 1200")  
STOCK NO. MA53 (3/4" x 600")

TEFLON TAPE



FEDERAL PROCESS BRAND TEFLON TAPE. STANDARD DENSITY PTFE TAPE.

STOCK NO. GASZT21 (1/2" x 520")

DUCK BUTTER



WATER SOLUBLE PIPE LUBRICANT FOR JOINING PIPE AND FITTINGS WITH RUBBER, SYNTHETIC RUBBER OR PLASTIC GASKETS. NON-TOXIC. FOR USE ON PW, DWV AND SEWER SYSTEMS. USABLE FROM 10° F TO 120° F.

STOCK NO. HER40501

PERMATEX PIPE JOINT COMPOUND



UNIVERSAL SEALANT. LUBRICATES AND SEALS THREADED JOINTS ON WATER, OIL AND FUEL LINES. TEMPERATURE RANGE -65°F TO 400°F; RESISTS COMMON SHOP FLUIDS. 16 OZ. BOTTLE

STOCK NO. AP80045

LEAK DETECTOR



EXTERIOR APPLICATION DIRECT FROM CONTAINER. IMMEDIATELY MAKES BIG, BRIGHT FLUORESCENT YELLOW BUBBLES IF THERE IS LEAKING GAS. WIDE USEFUL TEMPERATURE RANGE FROM -10°F. TO +200°F. FOR PIPE LINES, TANKS, COILS, CYLINDERS, VALVES, ETC. 8 OZ. CONTAINER.

STOCK NO. HER45801

FLUORESCENT GAS DETECTOR



SURE-CHEK LEAK DETECTOR HAS A TEMPERATURE RANGE FROM -55°F. TO 200°F LONG LASTING BUBBLES. FLUORESCENT FOR IMPROVED VISIBILITY. NON-CORROSIVE AND NON-TOXIC. APPROVED FOR OXYGEN SERVICE. 16 OZ. SPRAY BOTTLE.

STOCK NO. MA32850

THREAD SEALANT PASTE



SLIC-TITE PASTE WITH TEFLON IS A HEAVY-DUTY THREAD SEALING COMPOUND. USE ON METAL, PVC, CPVC, AND ABS PLASTIC PIPE THREADS. FOR SEALING WATER, AIR, STEAM, NATURAL GAS, LP GAS, REFRIGERANTS, AMMONIA, GASOLINE AND OIL. NON-TOXIC, NON-DRYING. SEALING TEMPERATURE RANGE -50°F. TO 500°F. BRUSH IN CAP.

STOCK NO. MA55 (8 OZ.)

NO. 5 PIPE RECTORSEAL

DEPENDABLE, MULTI-PURPOSE SEALANT. SOFT-SETTING, SLOW DRYING. CONTAINS NO HEAVY METALS. FREE OF HALOGENS. FOR METAL PIPE: IRON, GALVANIZED STEEL, STAINLESS STEEL, BRASS, COPPER, ALUMINUM. FOR PLASTIC PIPE: POLYETHYLENE, PVC AND REINFORCED FIBERGLASS. NOT RECOMMENDED FOR ABS OR CPVC. SEALING TEMPERATURE RANGE -50°F. TO 400°F.



STOCK NO. REC25431 (PINT)

PERMATEX THREAD SEALANT WITH PTFE



ECONOMICAL GENERALPURPOSE FITTING SEALANT. OUTPERFORMS TAPES AND PIPE DOPES. SEALS AND RESISTS PRESSURE IN AIR, OIL, DIESEL FUEL AND HYDRAULIC SYSTEMS. REMAINS PLIABLE AT HIGH AND LOW TEMPS. TEMPERATURE RANGE -65°F. TO 300°F. RESISTS COMMON SHOP FLUIDS.

STOCK NO. AP80632 (4 OZ)  
STOCK NO. AP80633 (16 OZ)

HYDRAULIC SEALANT



A MEDIUM-VISCOSITY ANAEROBIC SEALANT DESIGNED ESPECIALLY TO SEAL AGAINST LEAKAGE OF HYDRAULIC FLUIDS. PROVIDES A POSITIVE SEAL AGAINST SYNTHETIC FLUIDS AS WELL AS PETROLEUM-BASED FLUIDS. PRODUCT WILL FILL VOIDS AS LARGE AS .010 INCHES. CURES SUFFICIENTLY IN 4 HOURS. TEMPERATURE RANGE -65°F TO +300°F. 50cc.

STOCK NO. STL26931

TEFLON PIPE SEALANT



FOR STAINLESS STEEL AND ALL OTHER METAL ASSEMBLIES. INSTANT SEAL ON PIPE JOINTS. LOCKS AGAINST LEAKS WHEN FULLY CURED. ALSO PERFORMS ON NON-TAPER THREADED FITTINGS. SEAL IS IMPERVIOUS TO MOST CHEMICALS, SOLVENTS, GASSES AND MANY INDUSTRIAL ACIDS.

STOCK NO. GASAS05 (50ml)  
STOCK NO. GASAS25 (250ml)

HIGH TEMPERATURE SEALANT



FOR STAINLESS STEEL AND ALL OTHER METAL FITTINGS. ANTI-GALLING. NOT FOR USE ON PLASTIC PIPE. TEMPERATURE RANGE -65°F. TO +400°F. SUITABLE FOR USE WITH HYDROCARBONS, HALOCARBONS, ORGANIC ACIDS, ALCOHOLS, AND MILD MINERAL ACIDS & BASES. 1.69 FL. OZ

STOCK NO. LOC56747

ONE PAYDAY, AN EMPLOYEE RECEIVED AN UNUSUALLY LARGE CHECK. SHE DECIDED NOT TO SAY ANYTHING ABOUT IT. THE FOLLOWING WEEK, HER CHECK WAS FOR LESS THAN THE NORMAL AMOUNT, AND SHE CONFRONTED HER BOSS.

"HOW COME." THE SUPERVISOR INQUIRED, "YOU DIDN'T SAY ANTHING WHEN YOU WERE OVERPAID?" UNRUFFLED, THE EMPLOYEE REPLIED, "WELL, I CAN OVERLOOK ONE MISTAKE--BUT NOT TWO IN A ROW!"

## THREADLOCKERS, RETAINERS AND SEALANTS

### ANAEROBIC THREADLOCKERS



**LOW STRENGTH/ADJUSTABLE:** (PURPLE)  
HOLDS SMALL NUTS AND SCREWS. DOES NOT MIGRATE ON PARTS. SEALS MEDIUM SIZE THREADED PARTS. HOLDS TORQUE TENSION SPECS.

**STOCK NO. DENT22** (50cc)

**MEDIUM STRENGTH/REMOVABLE:** (BLUE)  
FAST CURE AND OIL TOLERANT. LOCKS NUTS AND SCREWS. DOES NOT MIGRATE ON PARTS. SEALS MEDIUM SIZE THREADED PARTS. HOLDS TORQUE TENSION SPECS. PREVENTS VIBRATION LOOSENING. CHEMICAL RESISTANT.

**STOCK NO. DENT4210** (10cc)

**STOCK NO. DENT42** (50cc)

**STOCK NO. DENT42250** (250cc)

**HIGH STRENGTH/PERMANENT:** (RED)  
LOCKS STUDS TO 1/2" DIAMETER. VERY CHEMICAL RESISTANT. ELIMINATES VIBRATION LOOSENING. ONLY REMOVABLE WITH HEAT. HIGH BREAK AND PREVAILING STRENGTH. SEALS AGAINST CORROSION.

**STOCK NO. DENT7010** (10cc)

**STOCK NO. DENT70** (50cc)

**STOCK NO. DENT70250** (250cc)

### ANAEROBIC RETAINING COMPOUND



GREEN. GENERAL PURPOSE. FAST CURE, HIGH STRENGTH, AND LOW VISCOSITY. USED FOR FIELD REPAIR (BEARINGS AND SHAFTS). WILL FILL .002 - .005 GAPS. EXCELLENT CHEMICAL RESISTANCE. PREVENTS FRETTING CORROSION. HIGH LOAD TRANSMISSION.

**STOCK NO. DENR01** (50cc)

### PENETRATING WICKING SEALANT



GREEN. HIGH STRENGTH AND LOW VISCOSITY. SEALS WELDING POROSITY. IDEAL FOR ADJUSTMENT SCREWS. FAST CURE.

**STOCK NO. DENS90** (50cc)

### PRIMER/ACTIVATOR



SPEEDS CURE OF ANAEROBIC ADHESIVES PARTICULARLY IN COLD CONDITIONS AND ON LESS ACTIVE SURFACES SUCH AS CADMIUM AND ZINC. 8 OZ.

**STOCK NO. DENPRIMERT**

### SEALANTS

#### WHITE RTV SILICONE



MAKES QUICK CUSTOM AND REPLACEMENT GASKETS. ADHERES TO MOST SURFACES. WATERPROOFS AND WEATHERPROOFS. STOPS LEAKS. FOR INTERIOR AND EXTERIOR USE. PERMANENTLY FLEXIBLE. 3 OZ.

**STOCK NO. DEN04**

#### RTV SILICONE CAULK



GENERAL PURPOSE SEALANT FOR GENERAL GLAZING AND CONSTRUCTION USE. HIGH PERFORMANCE. IDEAL FOR INDUSTRIAL SEALING, BONDING, GASKETING AND INSULATING APPLICATIONS. ADHERES TO GLASS, CERAMIC TILE, PLASTICS AND METALS. 10.3 OZ.

**STOCK NO. EL05** (ALMOND)

**STOCK NO. EL07** (CLEAR)

**STOCK NO. EL08** (WHITE)

**STOCK NO. EL09** (ALUMINUM)

**STOCK NO. EL10** (BLACK)

#### ACRYLIC SILICONE LATEX CAULK



ALL-PURPOSE FOR INDOOR/OUTDOOR USE. NON-SAG LATEX FORMS A TOUGH WEATHER-PROOF GASKET THAT SEALS OUT MOISTURE, WIND AND DIRT. PAINTABLE AFTER CURING. FOR DOORS, WINDOWS, BATHROOMS, SIDING, WALLBOARD AND TRIM. ADHERES WITHOUT CRACKING, PEELING OR SEPARATING. 10.3 OZ.

**STOCK NO. EL01**

#### WHITE BUTYL SEALANT CAULK



ADHERES TO ALL SURFACES- METAL, WOOD, PLASTIC, STONE. A HIGH GRADE, NON-SAG BUTYL RUBBER CAULK WHICH CURES THROUGH SOLVENT RELEASE TO FORM A FLEXIBLE SEAL. BONDS WITHOUT PRIMING. FORMULATED FOR SEALING METAL-TO-METAL PANELS, PRECAST CONCRETE JOINTS AND ROOF FLASHING. EXCELLENT ADHESION TO ALUMINUM, GALVANIZED STEEL, VINYL, BRICK, AND MOST PLASTIC MATERIALS. 10.3 OZ.

**STOCK NO. EL04**

### URETHANE SEALANTS



A HIGH-PERFORMANCE SEALANT. SELF-PRIMING AND DESIGNED TO SEAL DYNAMICALLY. BONDS TO CONCRETE, MASONRY, WOOD AND ALUMINUM. FAST-CURING AND EXCELLENT ELASTICITY. RESISTS DETERIORATION CAUSED BY STRESS. COMMON USES INCLUDE SEALING EXPANSION WALL JOINTS, CURTAIN WALL PANELS, FASCIA, AND AROUND ROOF CURBS, ROOF JACKS, SKYLIGHTS AND SMOKE VENTS. 10.3 OZ.

**STOCK NO. EL14** (LIMESTONE)

#### GREY LATEX ADHESIVE CAULK



WHITE LIGHTNING 3006 ALL PURPOSE CAULK IS A HIGH-PERFORMANCE CAULK THAT FEATURES EXCELLENT ADHESION TO MOST SURFACES. IDEAL FOR FILLING JOINTS AND OPENINGS AROUND DOORS, WINDOWS, ETC.

**STOCK NO. EL02**

#### EXPANDING FOAM SEALANT



POLYURETHANE INSULATES HARD-TO-REACH CRACKS, HOLES, VOIDS AND AREAS AROUND VENTS AND PLUMBING OR ELECTRICAL OUTLETS. EXPANDS 2-1/2 TO 3 TIMES. CURED FOAM WILL WITHSTAND A CONTINUOUS TEMPERATURE OF 240°F., BUT IS NOT CLASSIFIED AS A FIRE STOP MATERIAL. 12 OZ.

**STOCK NO. AFS393750**

### CAULKING GUNS

#### HEAVY-DUTY SKELETON GUN



1/10 HAND GUN. INSTANT THUMB-PRESSURE RELEASE. 5/16" DRIVE ROD FOR SMOOTH ACTION. SUPERIOR CAULKING THRUST. HOLDING COMFORT. CORROSION RESISTANT. HEAVY-GAUGE STEEL. 12-1/2" LONG. 1-1/2 LBS.

**STOCK NO. ELPJ510**

#### GENERAL PURPOSE CAULKING GUN



**STOCK NO. MD55400** (SM., 14 OZ. CARTRIDGE.)  
**STOCK NO. MD55401** (LG., QUART SIZE)

**AUTOMOTIVE AND INDUSTRIAL GASKET COMPOUNDS**

**GASKET MAKING MATERIAL**

**SHEET CORK**



EASY TO CUT AND USE. FOR AUTOMOTIVE, INDUSTRIAL AND HOUSEHOLD USE.

**STOCK NO. AP965C** (1/8" x 12" x 36")

**ASBESTOS FREE HIGH DENSITY MATERIAL**



ASBESTOS FREE HIGH DENSITY MATERIAL REPLACES COMPRESSED ASBESTOS. EASY TO CUT. FOR AUTOMOTIVE, INDUSTRIAL AND HOUSEHOLD USE. TEMPS NOT TO EXCEED 350°.

**STOCK NO. AP966C** (1/32" x 12" x 20")

**STOCK NO. AP967C** (1/16" x 12" x 20")

**POLYFLANGE SEALANT**



REPLACES MOST PROFESSIONAL GASKETS ON METAL SURFACES. IT WON'T SHRINK, TEAR OR CRACK AND PROVIDES MAXIMUM FACE-TO-FACE CONTACT OF MATED PARTS. PROVIDES AN INSTANT SEAL AT LOW PRESSURES AND FULLY CURES IN 1 TO 8 HOURS, DEPENDING ON PART CONFIGURATION AND CLEARANCE.

**STOCK NO. DENPFS50** (50cc)

**FLANGE SEAL**



PERFORMS LIKE "LIQUID VELCRO". FLEXIBLE, NON-HARDENING, REMOVABLE. FILLS GAPS TO .010 INCH AND SEALS MANY SURFACE FLAWS. VIBRATION RESISTANT. TEMPERATURE RANGE -60°F. TO +600°F. RESISTANT TO FUELS, GASES AND COOLANTS.

**STOCK NO. DENFST3** (3 OZ. TUBE)

**PACKING MATERIAL**



SQUARE BRAIDED CONSTRUCTION. NON-ASBESTOS FIBERS TREATED WITH A SPECIALLY FORMULATED BLEND OF LUBRICANTS OF A SAXOLINE BASE. EACH STRAND IS INDIVIDUALLY COATED WITH GRAPHITE AND THE BRAID IS SURFACE COATED WITH GRAPHITE. RECOMMENDED FOR GENERAL SERVICE ON ROTARY AND RECIPROCATING EQUIPMENT. FOR MILD ACIDS, ALKALINES, STEAM, BRINE, OIL. SPEEDS TO 1885 FPM; TEMPERATURES TO 450°F: PH RANGE 4-10.

STOCK NO	SIZE
AMP0075	1/8"
AMP0077	1/4"
AMP0078	3/8"
AMP0079	1/2"

**HIGH TACK GASKET SPRAY**



SPRAY-ON ADHESIVE SEALANT THAT HOLDS GASKETS IN PLACE DURING ASSEMBLY. SUITABLE TO 500°F. SEALS AND BONDS RUBBER, CORK, PAPER, FELT, METAL AND ASBESTOS GASKETS. DRIES QUICKLY TO A VERY TACKY FILM.

**STOCK NO. AP10** (MASTER BRAND - 12 OZ.)  
**STOCK NO. AP99MA** (PERMATEX BRAND - 12 OZ.)

**PERMATEX HIGH TACK GASKET SEALANT**



RED COLORED, ALL-PURPOSE SEALANT THAT HOLDS EVEN THE HEAVIEST OF GASKETS IN PLACE DURING ASSEMBLY. SEALS AND BONDS RUBBER, CORK, PAPER, FELT, AND METAL GASKETS. SETS QUICKLY TO A VERY TACKY FILM. SUITABLE TO 500°F. CONTAINS

NO OZONE-DEPLETING COMPOUNDS. RESISTS GASOLINE, OIL, KEROSENE, PROPANE AND BUTANE.

**STOCK NO. AP80063** (16 OZ. CAN)

**UNDERCOAT SPRAY**



MASTER BRAND RUBBERIZED UNDERCOAT SPRAY IS QUICK-DRYING AND PAINTABLE. PREVENTS RUST AND DEADENS SOUND. ELASTIC AND FLEXIBLE. 18 OZ. AEROSOL.

**STOCK NO. APUC20**

**RTV SILICONES  
 BLUE SILICONE**



USE FOR GASKET APPLICATIONS, INCLUDING OIL PAN, THERMOSTAT HOUSING, VALVE COVERS, WATER PUMP AND TIMING GEAR COVER. REPAIR-FRAYED WIRE INSULATION AND HOSE LEAKS. SAFE FOR USE ON ALL SENSOR EQUIPPED, COMPUTER-CONTROLLED VEHICLES. TEMPERATURE RANGE -80°F. TO 600°F.

**STOCK NO. AP61** (3 OZ. TUBE)  
**STOCK NO. AP80023** (12 OZ. TUBE)  
**STOCK NO. AP64** (10.3 OZ. CARTRIDGE)  
**STOCK NO. AP6MA** (8 OZ. AEROSOL GEL)

**RED SILICONE #7**



HIGH TEMPERATURE. USE FOR GASKET APPLICATIONS, INCLUDING EXHAUST MANIFOLDS, WATER PUMPS, TIMING CHAIN COVERS, OIL PANS, THERMOSTAT HOUSINGS, VALVE COVERS AND AXLE COVERS. REPAIRS FRAYED WIRE AND HOSE LEAKS. SAFE FOR USE ON ALL SENSOR EQUIPPED, COMPUTER-CONTROLLED VEHICLES. TEMPERATURE RESISTANT FROM -65°F. TO 500°F.

**STOCK NO. AP71** (3 OZ. TUBE)  
**STOCK NO. AP74** (10.3 OZ. CARTRIDGE)  
**STOCK NO. AP7A** (8 OZ. AEROSOL GEL)

**CLEAR SILICONE #9**



AN ALL PURPOSE ADHESIVE SEALANT FOR LEAKS AND IN GASKET AND ELECTRICAL APPLICATIONS. BONDS TO FELT, GLASS, WOOD, CORK, METAL, RUBBER, PAPER, PLASTICS, CERAMICS, LEATHER, TILE, VINYL, FABRICS, ASBESTOS GASKETS AND THE KITCHEN SINK.

**STOCK NO. AP91** (3 OZ. TUBE)  
**STOCK NO. AP9A** (8 OZ. AEROSOL)

**WEATHERSTRIP ADHESIVE**



FAST DRYING AND WATERPROOF. HIGH STRENGTH. RESISTS OILS AND SOLVENTS. ALSO USE FOR BONDING GASKETS TO METAL SURFACES, CARPETING, FLOOR MATS, TRUNK LINERS, HEAD LINERS. 5 OZ. TUBE.

**STOCK NO. AP8**



**AUTOMOTIVE AND INDUSTRIAL GASKET COMPOUNDS**



**FORM-A-GASKET**

RELIABLE, PASTE-LIKE GASKET SEALANTS/  
DRESSINGS/COATINGS.

**NO. 1**



RELIABLE PASTE-LIKE GASKET SEALANT/DRESSING/COATING. SETS QUICKLY TO A HARD SET AND IS RECOMMENDED FOR RIGID, PERMANENT ASSEMBLIES. USE TO 400°F. RESISTANT TO GASOLINE AND OTHER SOLVENTS.

STOCK NO. AP80003 (11 OZ. TUBE)

**NO. 2**



NON-HARDENING AND DRIES SLOWLY TO A PLIABLE FILM BEST SUITED FOR NON-RIGID, VIBRATING ASSEMBLIES SUCH AS ENGINES. LEAKPROOF TO WATER AND MOST LIQUID CHEMICALS. SUITABLE FOR CONTINUOUS TEMPERATURES UP TO 400°F.

STOCK NO. AP2B (3 OZ. TUBE)  
STOCK NO. AP2C (11 OZ. TUBE)

**AVIATION NO. 3**



A THIN, BRUSHABLE DRESSING OR SEALER FOR CLOSE FITTING PARTS. SUITABLE FOR CONTINUOUS TEMPERATURES UP TO 400°F.

STOCK NO. AP3H (4 OZ. BOTTLE)

STOCK NO. AP3D (16 OZ. BOTTLE)

**ULTRA-BLUE**



SILICONE GASKET FORMS TOUGH, FLEXIBLE GASKETS RIGHT IN PLACE. ADHERES TO OILY SURFACES AND IS THREE TIMES MORE OIL RESISTANT THAN MOST SILICONES. LOW ODOR. NON-CORROSIVE. USE UP TO 500°F. SENSOR SAFE. NO LEAK.

STOCK NO. AP77BR (3 OZ. TUBE)

**ULTRA-COPPER**



A PREMIUM, HIGH TEMPERATURE SILICONE GASKET MAKER THAT IS OIL RESISTANT AND CAN WITHSTAND CONTINUOUS TEMPERATURES TO 600°F. AND INTERMITTENT TEMPERATURES TO 650°F. LOW ODOR. NON-CORROSIVE. SENSOR SAFE.

STOCK NO. AP101BR (3 OZ. TUBE)

**ULTRA BLACK**



FAST-CURING FORMULA. SENSOR-SAFE, LOW ODOR, NON-CORROSIVE. FILLS GAPS OF UP TO .25" WHEN FULLY CURED. MEETS PERFORMANCE SPECS OF OEM SILICONE GASKETS. RETAINS HIGH FLEXIBILITY, OIL RESISTANCE PROPERTIES THROUGH USE OF A PATENTED ADHESION SYSTEM. TEMPERATURE RANGE -65°F TO 650°F INTERMITTENT. RESISTS AUTO AND SHOP FLUIDS AND VIBRATION.

STOCK NO. AP82180 (3.35 OZ. TUBE)

**"THE RIGHT STUFF"  
GASKET MAKER**



HEAVY-BODIED, BLACK, ELASTOMERIC RUBBER PROVIDES INSTANT SEAL. SUPERIOR FLEXIBILITY AND ADHESION ACCOMMODATES JOINT MOVEMENT. EXCELLENT OIL AND TRANSMISSION FLUID RESISTANT. NON-CORROSIVE. LOW ODOR. LOW VOLATILITY. USED ON AUTO ASSEMBLY LINES.

STOCK NO. AP25224 (7 OZ. TUBE)

**NONCONDUCTIVE DIELECTRIC  
GREASE**



IDEALLY SUITED FOR WATER PUMP BEARINGS, STARTER DRIVE ASSEMBLIES, AND ELECTRICAL CONNECTIONS EXPOSED TO THE ELEMENTS. SAFE ON RUBBER, NYLON AND VITON O-RING MATERIALS, AND A WIDE RANGE OF PLASTICS.

STOCK NO. JL32460 (5 OZ. TUBE)

**ANAEROBIC GASKET MAKER**



IDEAL FOR ON-THE-SPOT AND EMERGENCY REPAIRS. THIS SINGLE COMPONENT, THIXOTROPIC GASKET MAKER CURES RAPIDLY FOR A MEDIUM STRENGTH, SOLVENT RESISTANT SEAL THAT RESISTS TEMPERATURES UP TO 300°F.

STOCK NO. AP51813 (50cc TUBE)

**FAST ORANGE  
HAND SOAP W/PUMICE**



INDUSTRIAL GRADE, BIODEGRADABLE, WATERLESS, PETROLEUM SOLVENT-FREE HAND CLEANER. IT CONTAINS NO HARSH CHEMICALS, MINERAL OILS OR AMMONIA THAT CAN STING. PURE, FRESH-SMELLING NATURAL CITRUS POWER DOES THE CLEANING WHILE ALOE, LANOLIN, GLYCERIN AND JOJOBA CONDITION AND PROTECT SKIN.

STOCK NO. AP25218 (1 GAL.)

QUALITY  
PRODUCTS, FAIR  
AND  
COMPETITIVE  
PRICES,  
AND  
EXCELLENT  
SERVICE  
IS  
OUR REPUTATION



**CALL US TODAY!!**

ADHESIVES AND EPOXYS

HOT MELT GLUE GUN



RUGGED, INDUSTRIAL-GRADE GLUE GUN DELIVERS UP TO 4 POUNDS OF ADHESIVE AN HOUR. CONSTRUCTED OF IMPACT-RESISTANT PLASTIC AND FEATURING ALL-ELECTRIC SOLID STATE DESIGN. LIGHTWEIGHT. RELIABLE TEMPERATURE CONTROL. 3 HEATING ELEMENTS. INTER-CHANGEABLE NOZZLE. INDICATOR READY LIGHTS. 9-1/2" LONG.

STOCK NO. DEN425

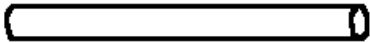

1/2" x 15" GENERAL PURPOSE GLUE STICK  
STOCK NO. DEN6390

CYANOACRYLATE ADHESIVES



INSTANT BONDERS

ONE COMPONENT, SOLVENT-FREE ADHESIVES THAT BOND INSTANTANEOUSLY WITH TENSILE SHEAR STRENGTH. 1 OZ. BOTTLES.

ETHYL TYPE. HOLDS FINE THREAD BOLTS AND SCREWS FROM VIBRATION LOOSENING. RECOMMENDED FOR O-RING BONDING. GOOD FOR PLASTIC AND NAME PLATING. VISCOSITY RANGE 90 - 120. GAP FILL .004.  
STOCK NO. DEN7432

ETHYL TYPE. SECURES KEYWAYS AND SPLINES AGAINST SHOCK LOADS. SLOW CURE TO ALLOW ASSEMBLY. VISCOSITY RANGE 2300 - 2700. GAP FILL .012.  
STOCK NO. DEN7532

METHYL TYPE. ELIMINATES VIBRATION LOOSENING AND FLUID LEAKAGE ON 1/4" - 1/2". GOOD FOR METAL & METAL/PLASTIC. VISCOSITY RANGE 40 - 50. GAP FILL .003.  
STOCK NO. DEN7430

METHYL TYPE. REINFORCES INTERFERENCE FITS. PREVENTS CORROSION AND SEIZURE. GOOD FOR METAL NAME PLATING. VISCOSITY RANGE 90 - 110. GAP FILL .003.  
STOCK NO. STL41131

WELD WOOD CARPENTER GLUE



PROFESSIONAL QUALITY ALPHATIC RESIN, WOOD AND MULTI-PURPOSE GLUE PROVIDING A HIGH STRENGTH BOND. SETS FAST, GRIPS TIGHT, SANDS EASILY WHEN DRY. HEAT, WATER AND SOLVENT RESISTANT. NON-TOXIC

STOCK NO. MD118103 (1 GAL.)

SPECIALTY EPOXY PUTTYS

REPAIR-IT-QUIK



REPAIR LOOSE OR CRACKED WALL OR FLOOR TILES. PATCH CHIPPED CONCRETE, BRICKS AND MASONRY. ELECTRICAL USE IN PLACE OF TAPE OR PLASTIC CONNECTOR. MEND HOLES.  
STOCK NO. PSI50560 (4 OZ. 7" STICK)

FAST-STEEL



MOLDS LIKE CLAY AND HARDENS LIKE STEEL. REPAIR FERROUS AND ALUMINUM METALS. REBUILD ENGINE PARTS, FILL CRACKS AND SEAL LEAKS. REPAIR STRIPPED THREADS ON NUTS AND BOLTS. WILL NOT RUST OR SHRINK.  
STOCK NO. PSI51060 (4 OZ. 7" STICK)

QUIK-ALUMINUM



FOR INDUSTRIAL AND HOME MAINTENANCE APPLICATIONS. STORM DOORS, ALUMINUM BOATS, RECREATIONAL VEHICLES, ALUMINUM CASTINGS, ALUMINUM TANKS, REFRIGERATION, AND ALUMINUM TUBING.  
STOCK NO. PSI57050 (4 OZ. 7" STICK)

QUIK-COPPER



REPAIRS COPPER, BRASS, BRONZE AND OTHER NON-FERROUS. REPAIR PLUMBING LEAKS IN 15 MINUTES. BONDS TO DAMP AND SLOW LEAKING SURFACES. SEALS LEAKS IN PIPE FITTINGS, TRAPS AND DRAINS.  
STOCK NO. PSI62560 (4 OZ. 7" STICK)

AQUA-MEND



REPAIRS TO DAMP OR WET AREAS AND UNDER-WATER APPLICATIONS. REBUILD HOLES IN FIBERGLASS, METAL AND WOODEN BOAT DECKS AND HULLS. REPAIR LEAKING GASKETS, WATER TANKS, SPAS, HOT TUBS, POOLS, ETC. EXCELLENT ADHESION TO PVC.  
STOCK NO. PSI70560 (4 OZ. 7" STICK)

QUIK-WOOD



FILL HOLES, SCRATCHES, GOUGES, CRACKS, DRY ROT AND KNOT HOLES. REPAIR FURNITURE, MOLDING AND FRAMES. RESHAPE WOODCARVINGS AND REMOLD KNOBS AND HANDLES. CAN BE SANDED, SAWED, PAINTED OR STAINED. INTERIOR OR EXTERIOR.  
STOCK NO. PSI71060 (2 OZ. 7" STICK)

QUIK-PLASTIK



FOR AUTOMOTIVE AND PLUMBING APPLICATIONS. PLASTIC TRIM, APPLIANCES, PARTS, SEAL LEAKS, PLASTIC OUTDOOR FURNITURE.  
STOCK NO. PSI75550 (4 OZ., 7" STICK)

SPECIALTY EPOXY PUTTYS

INSTACRETE



CONCRETE PUTTY FOR SEALING TIE-ROD HOLES, ANCHORING, REPAIR OF CHIPPED CONCRETE FLOORS, CURBING AND STEPS. CURES TO A CONCRETE COLOR. REPAIR MOLDINGS, STATUES, AND RELATED ORNAMENTS.

STOCK NO. PSI77550 (4 OZ., 7" STICK)

HEAT SEAL STIK



PRE-MIXED EPOXY FOR FAST REPAIRS. STICK MELTS, SEALS AND CURES IN ONE OPERATION. USE ON ALUMINUM, COPPER AND OTHER METALS, GLASS AND CERAMICS. IDEAL FOR USE ON HIGH AND LOW SIDE OF REFRIGERATION SYSTEMS. SEALING TEMPERATURE UP TO 350°F. PRESSURES TO 450 PSI.

STOCK NO. MA11575

OXYLITE STIK



TEMPORARY REPAIR OF GASOLINE AND OIL LEAKS WITHOUT DRAINING. APPLIES FROM THE OUTSIDE. FOR GASOLINE TANKS, FUEL OIL TANKS AND TRANSMISSIONS. PRESSURE TO 15 PSI.

STOCK NO. MA62

GORILLA GLUE



PROBABLY ONE OF THE BEST GENERAL PURPOSE GLUES ON THE MARKET. TYPICALLY REQUIRES ONE SIDED APPLICATION ONLY. GORILLA GLUE REQUIRES MOISTURE TO HARDEN. IT FOAMS ABOUT THREE TIMES ITS WET VOLUME TO SELF SPREAD AND PENETRATE MATERIAL SURFACES. CLAMPING IS NECESSARY. 8 OZ. BOTTLE

STOCK NO. LFT50008

STRUCTURAL ADHESIVE



HEAVY-DUTY STRUCTURAL AND SUB-FLOOR ADHESIVE BONDS DAMP OR FROZEN LUMBER, SUBFLOORING, DRYWALL, ALUMINUM, R-MAX SHEATHING, MASONRY/CONCRETE AND LAP SIDING. TEMPERATURE RANGE +35°F. TO 120°F.

STOCK NO. AFS25028 (10.3 OZ. CARTRIDGE)  
STOCK NO. AFS25117 (29 OZ. CARTRIDGE)

## EPOXY, REPAIR COMPOUNDS AND CONTACT CEMENTS

# Devcon.

### POLYSTRATE ADHESIVE 5-MINUTE EPOXY



STRONG AND FAST-ACTING. BONDS TO MOST METAL, CERAMIC, WOOD, CONCRETE OR GLASS IN ANY COMBINATION. RUGGED ADHESIVE TENSILE STRENGTH. FORMS A CLEAR, STRONG, RIGID BOND.

STOCK NO. DEV14250 (1 OZ. LIQUID)  
STOCK NO. DEV14240 (1 OZ. GEL)

### METAL REPAIR EPOXY

#### PLASTIC STEEL



CAN BE USED FOR MANY ROUTINE MAINTENANCE, PRODUCTION AND TOOLING APPLICATIONS. BONDS TO MOST METAL, CONCRETE AND SOME PLASTICS. FORMS A TOUGH, METALLIC MASS THAT CAN BE DRILLED, TAPPED, MACHINED OR PAINTED. EXCELLENT RESISTANCE TO OIL, GASOLINE, WATER AND MANY CHEMICALS. IDEAL FOR PATCHING AND LEVELING.

FAST-CURING 5-MINUTE PLASTIC STEEL EPOXY  
STOCK NO. DEV10240

PLASTIC STEEL PUTTY (1 LB.)  
STOCK NO. DEV10110

PLASTIC STEEL LIQUID (1 LB.)  
STOCK NO. DEV10210

ALUMINUM-FILLED EPOXY PUTTY FOR NON-RUSTING REPAIRS TO ALUMINUM CASTINGS, MACHINERY AND EQUIPMENT.  
STOCK NO. DEV10610 (1 LB.)

ALUMINUM-FILLED POURABLE EPOXY LIQUID FOR MAKING MOLDS, PATTERNS, HOLDING FIXTURES AND COSMETIC CASTING REPAIRS.  
STOCK NO. DEV10710 (1 LB.)

#### WEAR RESISTANT PUTTY

SMOOTH, NON-RUSTING, ALL-PURPOSE EPOXY PUTTY FOR REPAIRS REQUIRING LOW-FRICTION FINISHES, EXCELLENT WEAR RESISTANCE AND PROTECTION FROM BI-METALLIC CORROSION. BONDS TO STEEL, IRON, ALUMINUM, CERAMIC, CONCRETE, BRASS AND SOME PLASTICS.

STOCK NO. DEV11410 (1 LB.)

### RUBBER REPAIR AND CASTING URETHANES



**FLEXANE LIQUID** IS A CASTABLE, NON-SHRINKING AND MEDIUM VISCOSITY URETHANE COMPOUND. USED FOR MAKING RUGGED, FLEXIBLE MOLDS, FORMING DIES, CAST PARTS AND NON-SCRATCHING HOLDING FIXTURES, AS WELL AS ABRASION AND NOISE-RESISTANT LININGS AND ENCAPSULATING PARTS. DOES NOT CHANGE SHAPE WHILE CURING.  
STOCK NO. DEV15800 (1 LB.)

**FLEXANE FL-10 PRIMER** PROVIDES EXCELLENT ADHESION TO ALL METALS.  
STOCK NO. DEV15980 (4 OZ.)

### FAST-CURE EPOXY 45



PREMEASURED MIXER CUPS. NO MESS, GUESS OR WASTE. IDEAL FOR BONDING GLASS, HARD PLASTICS, RUBBER AND METAL. BONDS QUICKLY. LOOSE TRIM, BROKEN GRILLS, LOOSE DOOR GLASS CHANNELS AND CASTING CRACKS & HOLES.

STOCK NO. LOC44581 (10, 4g MIXER CUPS)

### 2-PART EPOXY



**PERMAWELD** COLD BONDING COMPOUND BONDS AND FILLS GAPS IN A WIDE VARIETY OF MATERIALS. DEVELOPS HIGH STRENGTH AND WITHSTANDS HIGH TEMPERATURES. RESISTANT TO MOST SHOP FLUIDS. USE ON CRACKED ENGINE BLOCKS, BATTERY AND TRANSMISSION CASES, CYLINDER HEADS AND ALTERNATORS.

STOCK NO. AP8265  
STOCK NO. APQW14 (4 MINUTE SET)



**AUVECO RIGID SET** IS A FAST SETTING AND HARD CURING REPAIR COMPOUND AND IS USED AS A FILLER OR SEALER. EXCELLENT FEATHER-EDGING. FOR AUTOMOTIVE, INDUSTRIAL AND HOME USE. STRONG ADHESION TO STEEL, GLASS, WOOD, CONCRETE, PLASTIC AND FIBERGLASS.

STOCK NO. AV1004

### FLOOR SAVERS FLOOR PATCH



AN ALL-PURPOSE CONCRETE REPAIR COMPOUND WITH A COMPRESSION STRENGTH OF 8000psi, THREE TIMES THE TYPICAL STRENGTH OF CONCRETE. EASY TO MIX AND APPLY. EXCELLENT ADHESION TO A VARIETY OF SUBSTRATES, CONCRETE, BRICK, MASONRY, METAL OR WOOD SURFACES. FLOOR PATCH REPAIRS ARE RESISTANT TO WATER, OILS, GASOLINE AND ALKALIS.

STOCK NO. DEV13100 (10 LB.)  
STOCK NO. DEV13120 (40 LB.)

### CONTACT CEMENTS



**DURO BRAND CONTACT CEMENT** BONDS QUICKLY. EASY-TO-USE, NO CLAMPS NEEDED. HEAT AND WATER RESISTANT. APPLICATOR INCLUDED. FOR METAL, WOOD, FLOOR TILE, LEATHER AND RUBBER. 3 OZ. BOTTLE.

STOCK NO. DUCC8



**WELDWOOD BRAND CONTACT CEMENT** OFFERS QUICK DRY TIME. RECOMMENDED FOR BONDING DECORATIVE LAMINATES, VENEERS, PANELING, WOOD, RUBBER, FOAM, CLOTH, LEATHER, PAPER, CORK, DRYWALL, PLYWOOD, GLASS, METAL OR FIBERGLASS. RESISTANT TO WATER AND WEATHER. SOLVENTS IN THIS PRODUCT MAY DAMAGE PAINTED SURFACES, VINYL AND OTHER PLASTICS. NOT FOR USE ON COPPER.

STOCK NO. AFS286590 (QUART)  
STOCK NO. AFS286825 (GALLON)

QUALITY PRODUCTS  
FAIR  
AND  
COMPETITIVE  
PRICES AND EXCELLENT  
SERVICE  
IS OUR  
REPUTATION

**ANTI-SEIZE AND LUBRICANTS**

**ANTI-SEIZE  
 E-Z BREAK COPPER**



NO MESS, DRIPS OR SPILLS. EASY TO APPLY. PROTECTS AGAINST GALLING, SEIZING AND CORROSION. NON-TOXIC, LEAD-FREE. NO WASTE. RESISTS TEMPERATURES TO 1800°F.

STOCK NO. MA08930 (2.25 OZ STICK)  
 STOCK NO. JC10004 (1 LB. CAN W/BRUSH)

**KOPR-KOTE® ANTI-SEIZE**



HIGH TEMP ANTI-SEIZE. IDEAL FOR THE MAJORITY OF APPLICATIONS INVOLVING HIGH TEMPERATURES, STRESS AND LOADS. COMPATIBLE WITH MOST METALS AND ALLOYS. NOT RECOMMENDED FOR USE ON ALUMINUM FITTINGS, FASTENERS OR OXYGEN SERVICE. RATED FOR TEMPERATURES -65°F. TO 1800°F.

STOCK NO. JL10050 (14 OZ. CARTRIDGE)  
 STOCK NO. JL10055 (4 OZ.)  
 STOCK NO. JL10002 (1/2 LB. BRUSH TOP CAN)

**ANTI-SEIZE  
 AND LUBRICATING COMPOUND**



FOR ULTIMATE PROTECTION TO OVER 2000°F. HELPS SPEED ASSEMBLY AND PREVENTS COLD WELDING OR CARBON FUSION. STOP GALLING, CORROSION AND SEIZURE. UNLIMITED APPLICATIONS. WATER WASHOUT RESISTANCE.

STOCK NO. DENNSBT16 (16 OZ. CAN)  
 STOCK NO. DENNS168 (8 LB. CAN)  
 STOCK NO. SO620 (SPRAY-ON 12 OZ. AEROSOL)

NICKEL-GRADE FORMULA FOR PROTECTION TO 2000°F. USED FOR DISSIMILAR METALS AND FOR STAINLESS STEEL.

STOCK NO. DENNSBT16N (16 OZ. CAN)

**FOOD / DRUG GRADE ANTI-SEIZE**



ANTI-SEIZE WITH PTFE HAS BEEN FORMULATED TO MEET RIGOROUS USDA REQUIREMENTS. IT IS ODORLESS, TASTELESS, NON-STAINING AND IS CORROSION-RESISTANT TO 500°F. THIS SUPERIOR PRODUCT PREVENTS GALLING ON THREADED JOINTS AND METAL WEAR SURFACES AND PERFORMS PARTICULARLY WELL ON STAINLESS STEEL

STOCK NO. STL80345

**NEVER SEEZ**



ANTI-SEIZE AND LUBRICATING COMPOUND. FOR MAXIMUM PARTS PROTECTION AND LUBRICATION AT TEMPERATURES 500°F. TO 1000°F. NO "DROPPING POINT", WON'T MELT OR RUN OUT. GOOD EXTREME PRESSURE LUBRICANT. CONTAINS NO METALLIC PARTICLES

STOCK NO. DENNHCT14B

**BEARING LUBRICANTS**

**HIGH TEMPERATURE BEARING LUBRICANT**



OFFERS PARTS PROTECTION TO OVER 550°F. WATER RESISTANT, GENERAL PURPOSE GREASE, OFFERING POSITIVE PROTECTION FOR EXTREME SERVICE. HIGHLY ADHESIVE TO METAL. PROVIDE HEAVY DUTY LONG LIFE PROTECTION.

STOCK NO. JL25050 (14 OZ. TUBE)

**RED-BEARING BEARING LUBRICANT**



CONTAINS POLYMER ADDITIVES TO FURTHER ENHANCE MOISTURE RESISTANCE INHERENT TO ALUMINUM COMPLEX-BASED GREASE. INORGANIC EP AND ANTI-WEAR ADDITIVES ALLOW THIS PRODUCT TO BE USED WHERE TOLERANCES ARE LOW AND SPEEDS/LOADINGS ARE HIGH. EXTREMELY CORROSION-RESISTANT.

STOCK NO. JL37750 (14 OZ. TUBE)  
 STOCK NO. JL37716 (35LB PAIL)

**WHITE LITHIUM LUBRICANT**



AN IDEAL LUBRICANT FOR AUTOMOTIVE APPLICATIONS, SUCH AS DOOR LOCKS AND HINGES. ALSO GOOD FOR HOUSEHOLD EQUIPMENT, BOATS, HARDWARE AND LAWN MOWERS. PREVENTS RUST.

STOCK NO. X14404 (1-3/4 OZ. TUBE)  
 STOCK NO. SO100 (SPRAY-ON BRAND 12 OZ. AERO)

**3-IN-ONE WHITE LITHIUM GREASE**



PROVIDES LONG-LASTING LUBRICATION FOR ALL METAL-TO-METAL APPLICATIONS. SPRAYS ON EVENLY. HEAVY DUTY. PREVENTS RUST AND CORROSION. WATER AND HEAT RESISTANT.

STOCK NO. WD10042

**WHITE LITHIUM GREASE**



RECOMMENDED FOR GENERAL AUTOMOTIVE AND INDUSTRIAL APPLICATIONS; NOT RECOMMENDED FOR DISC BRAKE WHEEL BEARINGS.

STOCK NO. AP11350 (1 LB. CAN)

**WHITE LITHIUM GREASE WITH PTFE**



MULTI-PURPOSE, WITH PTFE FOR ADDED LUBRICITY. IDEAL FOR METAL-TO-METAL LUBRICATION. INHIBITS RUST AND CORROSION. RESISTS HEAT AND WATER. ALL WEATHER FORMULA. LUBES AT TEMPERATURES RANGING FROM 0°F. TO 350°F.

STOCK NO. JL50316 (35 LB PAIL)

**SUPER MULTI-PURPOSE LITHIUM GREASE**



GENERAL AUTOMOTIVE AND INDUSTRIAL GREASE. IDEAL FOR NON-DISC BRAKE WHEEL BEARINGS (DRUMS), CHASSIS AND SUSPENSION. LUBES AT TEMPERATURES RANGING FROM 40°F. TO 320°F.

STOCK NO. JL31050 (14 OZ. CARTRIDGE)  
 STOCK NO. JL31016 (35LB PAIL)

**PREMIUM MULTI-PURPOSE LITHIUM GREASE**



IDEAL GREASE FOR EXTREME HIGH PRESSURE, HIGH TEMPERATURE APPLICATIONS. GOOD PUMPABILITY IN HOT AND COLD OPERATING CONDITIONS. AUTOMOTIVE AND INDUSTRIAL WHEEL BEARING APPLICATIONS. RED COLOR. SERVICE RATING: 0°F. TO 400°F.

STOCK NO. JL31750 (14 OZ. CARTRIDGE)  
 STOCK NO. JL31716 (35LB PAIL)

**MARINE MP™ #2 LITHIUM**



A GREASE WHICH IS IDEAL FOR A MULTITUDE OF APPLICATIONS. RESISTANT TO WATER, HEAT, ETC. SERVICE RATING: 0°F. TO 325°F.

STOCK NO. JL63016 (35 LB PAIL)

**LUBRIPLATE LUBRICANTS**

**MOTOR ASSEMBLY GREASE**



ESPECIALLY FOR MOTOR REBUILDING. WHITE PETROLEUM OIL GREASE IS WATERPROOF WITH ANTI-SEIZE PROPERTIES. ALSO RECOMMENDED FOR PRESS FITTINGS, SPRING ASSEMBLIES, DOOR HINGES, WHEEL AND NUT ASSEMBLIES, BATTERY TERMINALS, AND OTHER AUTOMOTIVE APPLICATIONS.

STOCK NO. AP3494 (10 OZ TUBE)

**MULTIPURPOSE**



POSSESS HIGH FILM STRENGTH AND EXCEPTIONAL RESISTANCE TO WATER, STEAM AND OTHER ADVERSE OPERATING CONDITIONS. FOR HIGH TEMP APPLICATIONS UP TO 375°F AND FOR SHORT INTERVALS UP TO 400°F. RECOMMENDED WHEREVER MICROGEL, BENTONE, UREA AND COMPLEX GREASES ARE RECOMMENDED AND USED. SUPERIOR FOR CERTAIN TYPES OF ENCLOSED GEAR CASES OF MEDIUM SPEED AND NO SEALS.

STOCK NO. LUB09801 (14 OZ CAN)

**GEAR LUBE**



THIS 80W-90 GEAR OIL IS BLENDED FROM SPECIALLY SELECTED PREMIUM BASE STOCKS AND COMPOUNDED WITH EXTREME PRESSURE, ANTI-FOAM, ANTI-OXIDANT, POUR POINT DEPRESSANTS, RUST AND CORROSION INHIBITORS AND "LIMITED SLIP" ADDITIVES.

STOCK NO. GU11

**LUBRICANTS**



**LPS NO. 1  
GREASELESS LUBRICANT**



LIGHT AND GREASELESS. A LUBRICANT FOR EVEN THE MOST DELICATE MECHANISMS. WON'T PICK-UP DUST OR DIRT. DRIES ELECTRONIC OR ELECTRICAL SYSTEMS IN SECONDS. EXCELLENT PENETRANT LOOSENS FROZEN PARTS. HARMLESS TO RUBBER, PAINT AND PLASTIC.

STOCK NO. LPS00116 (11 OZ. AEROSOL)  
STOCK NO. LPS01128 (1 GALLON)

**LPS NO. 2  
GENERAL PURPOSE LUBRICANT**



MEDIUM-OILY LUBRICANT AND RUST INHIBITOR. PROTECTS METALS AND LOOSENS RUSTY AND FROZEN PARTS. PROTECTS OUTDOOR ELECTRONIC SYSTEMS AGAINST RUST AND CORROSION. HARMLESS TO RUBBER, PAINT AND PLASTIC.

STOCK NO. LPS00216 (11 OZ. AEROSOL)  
STOCK NO. LPS02128 (1 GALLON)

**LPS NO. 3  
HEAVY-DUTY RUST INHIBITOR**



HEAVY-DUTY PROTECTION AGAINST RUST AND CORROSION UNDER SEVERE WEATHER AND/OR CHEMICAL CONDITIONS. FINEST CHAIN AND CABLE ANTI-SEIZE LUBRICANT. HARMLESS TO RUBBER, PAINT AND PLASTIC.

STOCK NO. LPS00316 (11 OZ. AEROSOL)  
STOCK NO. LPS03128 (1 GALLON)

**LPS RED & REDI  
MULTI PURPOSE RED GREASE**



DELIVERS EXCELLENT LUBRICATION. PREVENTS RUST, CORROSION AND OXIDATION. RED COLOR ALLOWS EASY VISUAL INSPECTION. REMAINS EFFECTIVE AT EXTREMELY HIGH TEMPERATURES 550°F. PENETRATES QUICKLY AND REDUCES FRICTION AND VIBRATION.

STOCK NO. LPS05816 (11 OZ. AEROSOL)

**LPS ELECTRA-X**



NON-CONDUCTIVE, NON-FLAMMABLE CONTACT CLEANER. LEAVES BEHIND NO RESIDUE WHILE DISPLACING MOISTURE. EVAPORATES FAST WITH QUICK PENETRATION. THE INVERTED SPRAY VALVE ALLOWS ONE TO SPRAY IN AN UPRIGHT OR INVERTED POSITION.

STOCK NO LPS00816

**TKX PENETRANT**



AN EXCELLENT LUBRICANT FOR CABLES, GEARS, AND CHAINS. TKX PROVIDES A NON-DRYING, OILY FILM FOR LUBRICATING EQUIPMENT AND MACHINES. DISPLACES MOISTURE WHILE LOOSENING RUSTED OR FROZEN PARTS. TKX HAS A HIGH FLASH POINT OF 175°F.

STOCK NO. LPS02016 (11 OZ. AEROSOL)  
STOCK NO. LPS02028 (GALLON)

**LPS THERMAPLEX  
HI-LOAD BEARING GREASE**



EXCELLENT LOAD CARRYING ABILITY. WITHSTANDS SHOCK LOADING. REDUCES WEAR FROM VIBRATION. CONTAINS 3% MOLY. GOOD CORROSION RESISTANCE. EXCELLENT ANTI-WEAR PROPERTIES. WIDE OPERATING TEMPERATURE RANGE.

STOCK NO. LPS70414 (14.1 OZ)

**EDGE LUBE**



BIODEGRADABLE CUTTING LUBRICANT IN A SOLID, WAXY BAR. FOR CUTTING TOOLS, GRINDING WHEELS OR BELTS. 13 OZ.

STOCK NO. LPS43200

**THE ORIGINAL ZOOM SPOUT OILER**

*Finest All-Purpose Oil  
Telescoping-Spout Reaches Everywhere*



PREMIUM TURBINE-GRADE LUBRICATING OIL FOR GENERAL APPLICATIONS. 14" "ZOOM SPOUT" IS FLEXIBLE TO MAKE IT EASIER TO REACH DIFFICULT AREAS. USE ON ROTATING AND RECIPROCATING EQUIPMENT, BEARINGS, MOTORS AND SLIDES. 4 OZ.

STOCK NO. MA79704

**RUST BUSTER™ PENETRANT**

LOOSEN RUSTY, FREES CORRODED PARTS IN SECONDS. A CHEMICAL PENETRANT-NOT A PENETRATING OIL-WORKS INSTANTLY, EVERY TIME. SPOUT TELESCOPES IN AND OUT, EXTENDING UP TO 14". SAFE FOR SKIN, CLOTHES, METALS AND FRICTION-TYPE SURFACES. NO LINGERING ODOR.



STOCK NO. MA79706

**LPS PREMIUM DI-ELECTRIC GREASE**



PROTECTS AND LUBRICATES ELECTRICAL CONTACTS. SEALS AND INSULATES. IMPROVES ELECTRICAL PERFORMANCE. WATERPROOFS ELECTRICAL CONTACTS. LUBRICATES RUBBER AND PLASTIC PARTS.

STOCK NO LPS03216

**IF YOU DON'T SEE  
SOMETHING HERE**

**YOU NEED,**

**GIVE US A CALL**

**WE WILL DO OUR BEST**

**TO FIND IT**

**FOR YOU**



LUBRICANTS

**"BLASTER"**

**PENETRATING CATALYST**



PB BLASTER LUBRICATES, COATS, PENETRATES AND CONDITIONS. FREES RUSTED OR FROZEN PARTS. REACHES INTO REMOTE CRACKS AND CREVICES. PINPOINT SPRAY NOZZLE. NON-EVAPORATING. ENVIRONMENTALLY SAFE.

STOCK NO. WES16PB (11 OZ. SPRAY)  
STOCK NO. WESPB128 (GALLON)

**BLASTER CUTTING FLUID**



EXTENDS TOOL LIFE BY COATING, PROTECTING AND LUBRICATING. ACTS AS A COOLANT BY PREVENTING HEAT FROM THE CHIP TO THE TOOL. ALSO INHIBITS RUST. QUICK PERFORMANCE RESULTS IN HIGH QUALITY PRECISION CUTS AND EDGES.

STOCK NO. WES16ETL (11 OZ. SPRAY)  
STOCK NO. WES128ETL (GALLON)

**BLASTER AIR TOOL CONDITIONER**



A FAST AND EASY WAY TO CLEAN, COAT AND LUBRICATE THE INTERNAL PARTS OF ALL AIR OPERATED TOOLS. PREVENTS BUILD-UP OF SLUDGE, CALCIUM, VARNISH AND MOISTURE. ALSO INHIBITS RUST.

STOCK NO. WES16ATC (11 OZ. SPRAY)

**BLASTER SILICONE LUBE**



PRESERVES, LUBRICATES AND PROTECTS ELASTOMERS, METAL, PLASTIC, WOOD, RUBBER, VINYL AND LEATHER. NON-EVAPORATING LUBRICANT. ELIMINATES WEAR FROM CONSTANT FRICTION. SAFE AND NON-STAINING.

STOCK NO. WESISL16 (11 OZ. SPRAY)

**BLASTER DRY LUBE WITH PTFE**



USE ON LOCKS AND CATCHES, HINGES, CABLES, WINDOW TRACKS AND GLASS, ROPE, DOOR TRACKS AND CONVEYOR BELTS. SUPERIOR, LONG-LASTING LUBRICATION. SAFE TO USE ON PLASTICS.

STOCK NO. WES16DDL (11 OZ. SPRAY)

**MARVEL AIR TOOL OIL**



ESPECIALLY ENGINEERED FOR THE CARE OF ALL PISTON-TYPE AND ROTARY AIR TOOLS. PREVENTS RUST FORMATION WHILE PROVIDING POSITIVE LUBRICATION FOR LONGER TOOL LIFE. DISSOLVES GUMS AND SLUDGE DEPOSITS.

STOCK NO. AP085 (1 QT.)

**RIDGID**

**THREAD CUTTING OILS**



COOLS THREADS AND PIPE DURING OPERATION. SPEEDS METAL REMOVAL. IDEAL FOR STAINLESS STEEL. REDUCES FRICTION AND GALLING, AND THEREBY PREVENTS FLUID RUPTURE BY TOOL PRESSURE. RIDGID TOOL CUTTING OILS ARE FREE OF CHLORINE AND OTHER HALOGENS. PCBs AND HEAVY METALS. LISTED AS NON-CARCINOGENIC.

**NU-CLEAR**

STOCK NO. RID41565 (QUART SPRAYER)  
STOCK NO. RID70835 (GALLON)  
STOCK NO. RID41575 (5 GALLON)

**DARK**

STOCK NO. RID41590 (QUART SPRAYER)  
STOCK NO. RID70830 (GALLON)  
STOCK NO. RID41600 (5 GALLON)

**TRI-FLOW™**



TRI-FLOW IS A SUPERIOR LUBRICANT CONTAINING HIGH-GRADE PETROLEUM OILS, TEFLON, CORROSION INHIBITORS, MOISTURE DISPLACERS, PENETRATING AIDS AND SPECIAL SOLVENTS TO SOFTEN AND REMOVE DIRT AND CORROSION.

STOCK NO. SOT21010 (2 OZ. SPRAY)  
STOCK NO. SOT20025 (6 OZ. SPRAY)  
STOCK NO. SOT20027 (12 OZ. SPRAY)



STOPS SQUEAKY METAL. LOOSENS RUSTED PARTS. FREES STICKY MECHANISMS.

STOCK NO. WD10152 (12 OZ. SMART STRAW)  
STOCK NO. WD10116 (16 OZ. INDUSTRIAL SIZE)  
STOCK NO. AP40101 (1 GALLON)

**3-IN-ONE**



THREE-IN-ONE MULTI-PURPOSE OIL HAS HUNDREDS OF USES. LUBRICATES, CLEANS, AND PREVENTS RUST. GOOD FOR IN THE HOUSE, ON THE CAR, IN THE OFFICE, ON THE SPORTS FIELD.

STOCK NO. WD10134 (4 OZ.)

**3-IN-ONE SILICONE SPRAY**



USE TO STOP SQUEAKS AND ELIMINATE STICKING. USE ON METAL AND NON-METAL SURFACES INCLUDING WOOD, VINYL, AND RUBBER. DRIES FAST AND LEAVES NO MESSY RESIDUE.

STOCK NO. WD10041 (11 OZ. SPRAY)

**3-IN-ONE HIGH-PERFORMANCE PENETRANT SPRAY**



WORKS FAST TO LOOSEN RUSTED OR STUCK PARTS. USE ON PIPES, FITTINGS, LOCKS, CHAINS, NUTS, BOLTS, TOOLS OR ANYTHING ELSE THAT NEEDS LOOSENING. HELPS PREVENT RUST AND CORROSION. CLEANS GREASE AND GRIME FROM METAL PARTS AND MECHANISMS.

STOCK NO. WD10040 (11 OZ. SPRAY)

## CUTTING FLUIDS & COOLANTS

### WAY LUBRICANT



HELPS REDUCE FRICTION AND DRAG THAT CAN CAUSE STICK SLIP PROBLEMS AND MACHINE TOOL CARRIAGE CHATTER. CONTAINS RUST AND CORROSION INHIBITORS TO PROTECT MACHINE PARTS AND PROVIDE GOOD THERMAL STABILITY. INTENDED FOR USE ON MACHINE TOOL SLIDES AND TABLES, CHAINS, CABLES AND OTHER PARTS REQUIRING TACKINESS AND SOME COMBINED HYDRAULIC AND TABLEWAY APPLICATIONS.

STOCK NO.	SIZE
BIO681	1 GAL.

### MISTIC AQUA SYN EP HEAVY DUTY OIL-FREE SYNTHETIC CUTTING AND GRINDING FLUID



MISTIC AQUA SYN EP IS A HEAVY-DUTY OIL FREE SYNTHETIC CUTTING AND GRINDING FLUID CONCENTRATE DESIGNED TO OFFER OUTSTANDING MACHINING PERFORMANCE AS WELL AS EXCELLENT CORROSION CONTROL ON MACHINERY AND WORKPIECES WHILE PROVIDING A LONG SUMP LIFE. THIS PRODUCT CAN BE USED ON A VARIETY OF METALS, INCLUDING STEELS, CAST IRON AND ALUMINUM; IN OPERATIONS RANGING FROM GRINDING TO TURNING TO MILLING. SINCE THIS PRODUCT IS COMPLETELY OIL-FREE, IT MAY BE USED IN MOST MIST COOLANT UNITS FOR MACHINING AND GRINDING OPERATIONS.

STOCK NO.	SIZE
COOL01	1 GAL.
COOL02	5 GAL.
COOL03	55 GAL.

**IF YOU DON'T SEE  
SOMETHING HERE YOU NEED,  
GIVE US A CALL.  
WE WILL DO  
OUR BEST  
TO FIND  
IT FOR YOU.**

### MISTIC AQUA OIL 20C BIOSTABLE SOLUBLE OIL



MISTIC AQUA OIL 20C IS A MINERAL BASED, BIOSTABLE WATER SOLUBLE CONCENTRATE ENGINEERED FOR RESISTANCE TO BIOLOGICAL AND CHEMICAL DEGRADATION WITHOUT THE USE OF BIOCIDES. THE MISTIC AQUA OIL 20C WILL MAINTAIN A CHEMICAL AND BIOLOGICAL BALANCE, OVER AN EXTENDED TIME PERIOD, MUCH LONGER THAN CONVENTIONAL FLUIDS, WITHOUT ANY DETERIORATION OF QUALITY. IN MACHINING OPERATIONS, ADDED LUBRICITY AND EXTREME PRESSURE AGENTS, ALLOW THIS PRODUCT TO OUTPERFORM THE STANDARD FLUIDS IN THE MARKETPLACE. EXCELLENT ON TOUGH ALLOYS SUCH AS STAINLESS STEEL, TITANIUM, AND HIGH SILICON ALUMINUM. SOME APPLICATIONS ARE: BROACHING, TAPPING, DRILLING, MILLING, TURNING AND GRINDING.

STOCK NO.	SIZE
05	5 GAL.
06	55 GAL.

### MISTIC AQUA SYN 30EP+ HIGH-PERFORMANCE BIOSTABLE OIL-FREE SYNTHETIC CUTTING AND GRINDING FLUID



MISTIC AQUA SYN 30EP+ IS A HEAVY DUTY OIL FREE SYNTHETIC CUTTING AND GRINDING FLUID CONCENTRATE DESIGNED TO OFFER OUTSTANDING MACHINING PERFORMANCE IN EVEN THE MOST DEMANDING APPLICATIONS. MISTIC AQUA SYN 30EP+ HAS BEEN DESIGNED FOR MACHINING AND GRINDING MOST METALS, INCLUDING STAINLESS STEELS, TOOL STEELS AND ALLOYS. FORMULATED TO PREVENT STAINING OR CORROSION ON COPPER, BRASS, BRONZE OR ALUMINUM. EXCELLENT ON CAST IRON. THIS PRODUCT MAY ALSO BE USED FOR GRINDING: BLANCHARD, DIAMOND WHEEL, CENTERLESS, BELT, DISK, ETC. THIS SHOULD NOT BE USED FOR GRINDING MAGNESIUM.

STOCK NO.	SIZE
15	5 GAL.

### MISTIC AQUA SEMI SYN 10 BIOSTABLE SEMI-SYNTHETIC CUTTING AND GRINDING FLUID



MISTIC AQUA SEMI SYN 10 IS A CHLORINE-FREE BIOSTABLE SEMI-SYNTHETIC WATER EXTENDIBLE FLUID CONCENTRATE DESIGNED FOR MACHINING AND GRINDING VIRTUALLY ALL METAL EXCEPT MAGNESIUM. BIOSTABILITY PROVIDES VERY LONG SUMP LIFE IN A PROPERLY MAINTAINED MACHINE TOOL AND DIMINISHES THE POSSIBILITY OF "MONDAY MORNING ODOR". ALL METALWORKING APPLICATION SUCH AS TURNING, MILLING, DRILLING, SAWING, BROACHING, TAPPING AND GRINDING.

STOCK NO.	SIZE
09	5 GAL.

### MISTIC MACHINE CLEANER WATER-BASED ALKALINE MACHINE AND PARTS CLEANER



MISTIC MACHINE CLEANER IS A LOW FOAM LIQUID ALKALINE CLEANER DESIGNED TO REMOVE PROCESS OILS, GUMMY DEPOSITS OF OIL, GREASE, SWarf AND NORMAL SHOP SOILS FROM MACHINES, FLOORS AND OTHER HARD SURFACES. IT COMBINES ORGANIC AND MINERAL ALKALINITY BUILDERS DETERGENTS, WATER CONDITIONER AND DEODORIZER. ITS PRIMARY APPLICATION IS FOR CLEANING OF MACHINE TOOL SUMPS AND SURFACES, ESPECIALLY RECIRCULATING COOLANT SYSTEMS. MISTIC MACHINE CLEANER MAY ALSO BE USED FOR GENERAL SHOP CLEANING WITH MOP AND BUCKET, AUTOMATIC SCRUBBER OR SPRAY WASHER.

STOCK NO.	SIZE
COOL10	5 GAL.

WIFE: "THERE'S TROUBLE WITH THE CAR. IT HAS WATER IN THE CARBURETOR."  
HUSBAND: "WATER IN THE CARBURETOR? THAT'S RIDICULOUS."  
WIFE: "I TELL YOU THE CAR HAS WATER IN THE CARBURETOR."  
HUSBAND: "YOU DON'T EVEN KNOW WHAT A CARBURETOR IS. WHERE'S THE CAR?"  
WIFE: "IN THE SWIMMING POOL."



**CUTTING FLUIDS**

**TAPFREE 2**



ENVIRONMENTALLY-SAFE. A FEW DROPS DOES THE JOB. USE FOR EASY DRILLING, THREADING, REAMING, TAPPING, MILLING, BORING OR BROACHING. UNIQUE HYDRO-LUBE FORMULA PROVIDES MAXIMUM LUBRICITY. PRECISION CUTS WITH A SMOOTH FINISH. EXTENDS TOOL LIFE. CONTAINS NO 1,1,1-TRICHLOROETHANE. NO HAZARDOUS CHEMICALS OR VAPORS. NO OIL RESIDUE. EASY CLEAN-UP.

- STOCK NO. WB05 (4 OZ.)
- STOCK NO. WB13 (PINT)
- STOCK NO. WB14 (GALLON)
- STOCK NO. WB12 (5 GALLON)

**TAPFREE Excel**



HEAVY-DUTY, OIL-BASED CUTTING FLUID. CLINGS TO TOOL FOR BETTER HOLD ON HORIZONTAL OPERATIONS AND LESS PRODUCT USAGE. HIGH PERFORMANCE. LOW ODOR. ESPECIALLY EFFECTIVE ON HARD TO MACHINE METALS SUCH AS STAINLESS STEEL, TITANIUM AND EXOTIC ALLOYS. CLEANS UP WITH PETROLEUM SOLVENTS OR AQUEOUS ALKALINE CLEANERS. SAFE FOR USE ON ALL METALS.

- STOCK NO. WB18 (4 OZ.)
- STOCK NO. WB15 (PINT)
- STOCK NO. WB16 (GALLON)
- STOCK NO. WB17 (5 GALLON)

ADDITIONAL PRODUCTS AVAILABLE  
UPON REQUEST

**CleanTap**



A SYNTHETIC, AQUEOUS-BASED CUTTING FLUID DEVELOPED FOR USE ON OPERATIONS WHERE THE PRESENCE OF CERTAIN CHEMICALS CANNOT BE TOLERATED. IT PROVIDES EXCEPTIONAL PERFORMANCE WITHOUT THE USE OF OIL, CHLORINE, SULPHUR, SILICONE OR FREE FATTY ACIDS. RECOMMENDED FOR ALL JOBS WHERE CORROSION IS OF PRIME CONCERN. HELPS IMPROVE SURFACE FINISH. EASY CLEAN-UP WITH WATER.

- STOCK NO. WB09 (4 OZ.)
- STOCK NO. WB10 (PINT)
- STOCK NO. WB11 (5 GALLON)

THIS SPACE RESERVED FOR FUTURE  
CUTTING FLUIDS

**WATER SOLUBLE OIL**



USED FOR LIGHT MACHINING AND ESPECIALLY RECOMMENDED FOR GRINDING OPERATIONS WHERE VERY LEAN EMULSIONS ARE TYPICALLY REQUIRED TO PERMIT RAPID SETTLING OF "FINES" (FINE PARTICLES). HELPS KEEP EMULSION CIRCULATING-LINES CLEAN AND ALLOWS FREE FLOW OF COOLANT TO THE WORKPIECE. THE ABSENCE OF RECIRCULATED FINES KEEPS GRINDING WHEELS FREE-CUTTING; THUS PROVIDING EXCELLENT FINISHES AND PROMOTING LONGER WHEEL LIFE.

- STOCK NO. GU04 (5 GALLON)

**AlumTap**



FOR QUICK, PRECISE ALUMINUM MACHINING. USE FOR TAPPING, DRILLING, MILLING AND BROACHING. ELIMINATES GALLING AND TEARING. NON-STAINING. PLEASANT ODOR. CONTAINS NO SULPHUR, FATTY ACIDS OR WETTING AGENTS. SUITABLE FOR RECIRCULATING SYSTEMS.

- STOCK NO. WB06 (4 OZ.)
- STOCK NO. WB01 (PINT)
- STOCK NO. WB08 (GALLON)

**ULTRA LUBE**



SUPER CONCENTRATED NO RUN FORMULA. CLINGS TO VERTICAL SURFACES FOR CONTINUAL LUBRICATION. RICH GOLD COLOR AND THICK CONSISTENCY GIVES A QUALITY APPEARANCE NOT AVAILABLE WITH THIN RUNNY FLUIDS. VIRTUALLY SMOKE FREE IN EVEN THE MOST HEAT PRONE APPLICATIONS. THIS FLUID WILL EXTEND TOOL LIFE AND YIELD A SUPER SMOOTH MACHINED FINISH.

- STOCK NO. CD96070

**WE KNOW YOUR  
NEEDS,  
LET US  
SHOW YOU  
HOW MUCH WE  
CARE!!**

*QUALITY  
PRODUCTS  
FAIR  
AND  
COMPETITIVE  
PRICES  
AND  
EXCELLENT  
SERVICE  
IS  
OUR  
REPUTATION!*

## INDUSTRIAL AND AUTOMOTIVE CHEMICAL PRODUCTS

### MARVEL MYSTERY OIL



ADD THIS OXIDATION-RESISTANT SOLVENT OIL TO GASOLINE FOR OPTIMUM TOP-CYLINDER LUBRICATION. PREVENTS WEAR, IMPROVES COMPRESSION, PERFORMANCE & GAS MILEAGE, AND RETARDS VARNISH AND GUM FORMATION. ALSO USED IN DIESEL ENGINES, AIR HAMMERS AND MACHINERY. ADD TO CRANKCASE OILS FOR EASIER WINTER STARTS AND EXTRA HOT WEATHER PROTECTION.

STOCK NO. AP014 (GALLON)

### STP OIL TREATMENT



FORMULATED TO REDUCE ENGINE WEAR AND KEEP ENGINES CLEAN WITH AN ANTI-WEAR AGENT, VISCOSITY IMPROVER, CORROSION FIGHTER AND ACID INHIBITOR.

STOCK NO. AP101526 (15 OZ.)

### GAS LINE ANTI-FREEZE



FOR FASTER WINTER STARTING. PREVENTS GAS LINE AND FUEL SYSTEM FREEZE UPS. ABSORBS MOISTURE AND STOPS RUST.

STOCK NO. APGA12 (12 OZ.)

### DIESEL FUEL ANTI-GEL & CONDITIONER



RETARDS GELLING DURING COLD WEATHER PERMITTING FUEL TO FLOW FREELY. CONTAINS CONDITIONERS TO CLEAN FUEL LINES AND FILTERS YEAR ROUND. DISPERSES WATER AND HELPS CLEAN INJECTORS.

STOCK NO. APDFC12 (12 OZ.)

### STARTING FLUID



FOR ALL GASOLINE AND DIESEL ENGINES. CONTAINS UPPER CYLINDER LUBRICANT.

STOCK NO. APSF16 (11 OZ.)

### BRAKE FLUID



DOT 3 MOTOR VEHICLE BRAKE FLUID. SUPER HEAVY-DUTY 450° HIGH TEMPERATURE.

STOCK NO. APFF12P (12 OZ.)

STOCK NO. APFF168 (GALLON)

### AIR BRAKE ANTI-FREEZE



ANTI-FREEZE AND RUST INHIBITOR NEEDED FOR ALL AIR BRAKE SYSTEMS. COMPLETE WINTER PROTECTION FOR ALL AIR BRAKE SYSTEMS.

STOCK NO. APAB32 (32 OZ.)

### CARBURETOR CLEANER



CLEANS AND FREES AUTO CHOKES, CARB LINKAGE, HEAT RISERS AND PCV SYSTEM. DISSOLVES DEPOSITS SUCH AS GUM, SLUDGE AND VARNISH TO IMPROVE FUEL SYSTEM PERFORMANCE AND INSURE MAXIMUM FUEL ECONOMY. SAFE FOR USE WITH OXYGEN SENSORS AND CATALYTIC CONVERTERS.

STOCK NO. APCB24 (20 OZ. SPRAY)

### RUBBERIZED UNDERCOAT



QUICK DRYING. PAINTABLE. SEALS AND PROTECTS YOUR VEHICLE AGAINST MOISTURE, RUST AND CORROSION. QUIETS SQUEAKS, INSULATE AND DEADEN NOISE. USE UNDER AUTO FENDERS, FIREWALLS, FRAMES, INSIDE DOOR PANELS, ROCKER PANELS, GAS TANKS, ETC. USE ON FARM IMPLEMENTS, ROOFS AND GUTTERS.

STOCK NO. APUC20 (18 OZ. SPRAY)

ADDITIONAL ITEMS AVAILABLE UPON REQUEST

### BRAKE CLEANERS MASTER BRAND



HELPS REMOVE BRAKE FLUID, OIL, GREASE AND OTHER CONTAMINANTS FROM BRAKE LININGS, DRUMS AND OTHER BRAKE PARTS. CAN BE USED WITHOUT DISASSEMBLING THE BRAKE UNIT. NON-CHLORINATED. FLAMMABLE

STOCK NO. APBCN20A (18 OZ. SPRAY)

### BATTERY PROTECTOR



SEALS AND PROTECTS FOR LONGER LIFE. HELPS ELIMINATE CORROSION ON TERMINALS, HOLDERS AND CLAMPS.

STOCK NO. AP80370 (6 OZ. SPRAY)

### MOTOR OIL



A PREMIUM QUALITY, MULTIGRADE ENGINE OIL, FORMULATED FROM SELECTED SUPERIOR BASE OILS AND ADVANCED ADDITIVE TECHNOLOGY. MEETS OR EXCEEDS ILSAC GF-4 STANDARDS AND API SERVICE SM. ADVANCED WEAR, VARNISH AND SLUDGE PROTECTION. ADVANCED PROTECTION AGAINST THERMAL BREAKDOWN. MEETS OR EXCEEDS ENERGY CONSERVING STANDARDS.

STOCK NO. GU081 5W20 (32 OZ)

STOCK NO. GU08 10W30 (32 OZ)

STOCK NO. GU09 10W40 (32 OZ)

### SYNTHETIC BLEND MOTOR OIL



A SYNTHETIC BLEND ENGINE OIL, FORMULATED FROM SELECTED SUPERIOR BASE OILS AND ADVANCED ADDITIVE TECHNOLOGY. MEETS OR EXCEEDS ILSAC GF-4 STANDARDS AND API SERVICE SM. ADVANCED WEAR, VARNISH AND SLUDGE PROTECTION. ADVANCED PROTECTION AGAINST THERMAL BREAKDOWN. MEETS OR EXCEEDS ENERGY CONSERVING STANDARDS.

STOCK NO. GU082 5W30 (32 OZ)

**INDUSTRIAL AND AUTOMOTIVE CHEMICAL PRODUCTS**

**BATTERY TERMINAL CLEANER**



REMOVES CORROSION INSTANTLY. SPRAY ON BATTERY TERMINALS, METAL CONNECTORS, AND BRACKETS.

STOCK NO. APBTC8

**ICE MELTER SPRAY**



MELTS ICE FAST. USE FOR LOCKS, WIPERS AND WINDOWS. HARMLESS TO CAR FINISHES. 11.5 OZ.

STOCK NO. APWD16

**WASHER FLUID**



WINDSHIELD WASHER SOLVENT PROTECTS TO -20° F. GALLON CONTAINER.

STOCK NO. MD9991349

**HYDRAULIC OIL**



PREMIUM QUALITY, ANTI-WEAR HYDRAULIC OIL THAT CONTAINS RUST, OXIDATION, AND FOAM INHIBITORS. DESIGNED FOR USE WITH ALL VANE AND PISTON-TYPE HYDRAULIC PUMPS, AS WELL AS CIRCULATING SYSTEMS, COMPRESSORS, AND OTHER INDUSTRIAL

EQUIPMENT. FORMULATED TO MAINTAIN SYSTEM SEAL INTEGRITY AND PROVIDE ALL-TEMPERATURE PERFORMANCE.

STOCK NO. GUO1 (5 GAL. 15W GRADE 46)  
 GUO12 (5 GAL. 10W GRADE 32)

**ALUMASEAL**



YEAR-ROUND COOLING SYSTEM SEALER AND CONDITIONER FOR CARS, TRUCKS AND TRACTORS. A QUICK, PERMANENT REPAIR FOR PLASTIC AND METAL RADIATORS. EFFECTIVE WITH ALL TYPES OF ANTI-FREEZE. STOPS ENGINE OVERHEATING. COATS WITH A RUST INHIBITOR. REDUCES WATER PUMP SQUEAKING. CONCENTRATED POWDER IN A 20g PLASTIC VIAL.

STOCK NO. APASD24

**PERMANENT ANTI-FREEZE/COOLANT**



UNIVERSAL FORMULATION FOR ALUMINUM AND ALL OTHER METAL ENGINES. WILL NOT EVAPORATE. GALLON.

STOCK NO. GU02



FOR EASIER STARTING AND LONGER BATTERY LIFE. TERMINALS CORROSIVE-FREE. 1 SET PER PACK (POS/NEG).

STOCK NO. AP15

ANYTHING ELSE  
 YOU NEED?  
 PLEASE LET US KNOW!!



**TIRE SEALER**



A SPECIAL HEAVY-DUTY LATEX FORMULA THAT SEALS AND INFLATES TUBE AND TUBELESS TIRES INSTANTLY.

STOCK NO. APTT16 (12 OZ.)

**FUEL STABILIZER**



FOR QUICK STARTS AFTER STORAGE AND ALL YEAR ROUND. KEEPS FRESH FUEL FRESH. NOW TREATS UP TO 10 GALLONS.

STOCK NO. AP1104 (4 OZ.)

**AUTOMATIC TRANSMISSION FLUID**



DEXRON-III MERCON, A MULTI-PURPOSE FLUID RECOMMENDED FOR GM, CHRYSLER AND MOST FOREIGN AUTOMOBILES WHERE DEXRON-III OR MERCON ARE RECOMMENDED.

STOCK NO. GU10

"SIR, YOU WERE DOING 63 IN A 55 ZONE."  
 "I WAS NOT SPEEDING!" INSISTS THE MAN.  
 "YOUR RADAR GUN MUST BE BROKEN."  
 AT THIS POINT THE WIFE LEANS OVER. "IT'S  
 NO USE ARGUING WITH HIM, OFFICER," SHE  
 SAYS APOLOGETICALLY. "HE ALWAYS GETS THIS  
 STUBBORN WHEN HE'S BEEN DRINKING."

### HAND CLEANERS

#### GENT-L-KLEEN ORIGINAL



GENT-L-KLEEN IS A COSMETIC QUALITY SKIN CLEANSING CREAM WHOSE THOROUGH AGENTS REMOVE EVERY TRACE OF DIRT ON CONTACT-ACIDS, PAINT, PRINTING INK, ASPHALT, CREOSOTE, RUBBER GASKET CEMENTS, INDUSTRIAL CARBON AND GREASE. ITS COSMETIC GRADE SYNTHETIC CLEANING AGENTS WON'T

IRRITATE THE SKIN. IT WON'T EVEN IRRITATE OPEN CUTS OR SORES. AND, GENT-L-KLEEN DOES NOT HAVE THE PETROLEUM ODOR FOUND IN PRODUCTS CONTAINING LOW-COST PETROLEUM DISTILLATES. 7 LB. CAN; 6 UNITS PER CASE.

STOCK NO. GK176

#### GENT-L-KLEEN ORIGINAL PUMICIZED



PUMICIZED GENT-L-KLEEN HAND CLEANER HAS THE SOOTHING FEEL OF THE ORIGINAL COSMETIC FORMULA WITH A TOUCH OF SPECIAL, FINE COSMETIC-GRADE PUMICE TO MOVE EVEN THE TOUGHEST GRIME WITH A GENTLE CLEANING ACTION. IT WILL LEAVE EVEN THE ROUGHEST HANDS WITH A SMOOTH, SOFT FEEL. 7 LB. CAN; 6 UNITS PER CASE.

STOCK NO. GK676

#### GRIME GRABBER



DEVELOPED TO GIVE YOU A HAND CLEANER THAT WAS TOUGH ENOUGH TO GRAB ALL THE GRIME, YET MILD ENOUGH TO CONDITION THE SKIN. AND ALL THESE BENEFITS ARE AT A PRICE UNDER MOST OTHER ECONOMY HAND CLEANERS. DOES NOT CONTAIN ANY STRONG SOLVENTS. NON-ABRASIVE, YET TOUGH ON DIRT. 7 LB. CAN; 6 UNITS PER CASE.

STOCK NO. GK276

#### GRIME GRABBER PUMICIZED



DEVELOPED TO MEET YOUR NEEDS FOR A QUICK, EFFICIENT DOUBLE-DUTY HAND CLEANER. IT IS A COMBINATION OF WATERLESS AND FRICTION-TYPE HAND CLEANERS THAT SPEED CLEAN-UP TIME. 7 LB. CAN; 6 UNITS PER CASE.

STOCK NO. GK376

#### LAVA



OUTSTANDING CLEANING PERFORMANCE. LAVA'S PUMICE HELPS POWER DIRT AND GREASE AWAY.

CLEANS DIRT BETTER THAN OTHER BAR SOAPS. THE LEADING HEAVY DUTY HAND CLEANING BAR AVAILABLE. 4 OZ.

STOCK NO. LAVA1

#### DISPENSER



7 POUND CAN PLASTIC DISPENSER.

STOCK NO. GK07110 (WALL MOUNT)

#### GOJO



ORIGINAL FORMULA FORTIFIED WITH LANOLIN. CLEANS WITH OR WITHOUT WATER.

STOCK NO. AP1115 (4.5 LB.)

#### K-GARD HEAVY DUTY HAND CLEANER



HEAVY DUTY HAND CLEANER. TRIPLE ACTION: ANTISEPTIC, CONDITIONS SKIN AND CLEANS THOROUGHLY. SOOTHES AS IT CLEANS. REMOVES INK, PAINT, GRIME, OIL, TAR, ADHESIVE, PUTTY, STAINS, GRAPHITE, CARBON, SHELLAC,

VARNISH, GREASE AND ASPHALT.

STOCK NO. KAY3154 (GALLON)

STOCK NO. KAY3162 (12 OZ.)

#### "SPLASH" PINK SKIN CLEANER



A GENTLE, ALL-PURPOSE LOTION SKIN CLEANSER WITH A PLEASANT FRAGRANCE. MILD ON SKIN. GIVES A QUICK, RICH LATHER. LEAVES SKIN CLEAN AND REFRESHED. USE DISPENSER GK01111 OR GK01600.

STOCK NO. SBS07105

#### BORAXO POWDER HAND SOAP



A WHITE BLEND THAT USES BORAX AS THE SCRUBBER TO EASILY LIFT GREASE AND GRIME FROM THE SKIN. QUICK-SUDSING AND FREE-RINSING. USE DISPENSER SBS97112.

STOCK NO. SBS21150

#### DISPENSER



DISPENSER FOR POWDERED SOAPS. BULK FILL.

STOCK NO. SBS97112

#### CITRUS LOTIONS



PREMIUM, ALL NATURAL CLEANING AGENTS DISSOLVE GREASE AND HARD-TO-REMOVE SOILS. BIODEGRADABLE FORMULA WITH CONDITIONERS. 1 GALLON PLASTIC CONTAINERS; 4 UNITS PER CASE.

STOCK NO. GK121400



PUMICIZED CITRUS LOTION IN 22 OZ. TUBES. 12 TUBES PER CASE.

STOCK NO. GK122212

#### ANTI-BACTERIAL LOTION SOAP



STOCK NO. SBS76105

#### DISPENSERS & BRACKET



1 LITER CAPACITY DISPENSER W/ SEE-THROUGH RESERVOIR

STOCK NO. GK01111

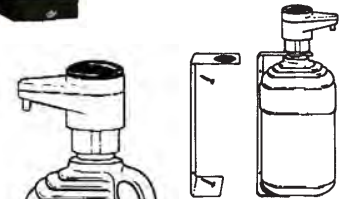

HEAVY-DUTY DISPENSER FOR GALLON JUGS. STOCK NO. GK01600

STAINLESS STEEL WALL BRACKET FOR GALLON JUG. STOCK NO. GK01000

#### K-GARD HEAVY DUTY DISPENSER



HEAVY DUTY DISPENSER FOR THE GALLON SIZE K-GARD CLEANER.

STOCK NO. KAY1127

#### INSTANT HAND SANITIZER



SUPPLEMENT ROUTINE HANDWASHING TO DECREASE BACTERIA ON THE SKIN. APPLY TEASPOON ON HAND AND RUB UNTIL DRY. DO NOT RINSE

STOCK NO. SC93060

**HAND CLEANERS**

**DISPENSER MATE 5000  
 DISPENSING SYSTEM**

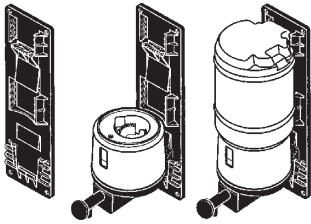

REDUCES SERVICE CYCLES WITH LARGE CAPACITY REFILL TANK AND RESERVOIR. NO WASTE, TANK EMPTIES COMPLETELY. SEE-THROUGH WINDOW LETS USER KNOW WHEN TO CHANGE REFILL. WHEN REFILL IS EMPTY, RESERVOIR ALLOWS SYSTEM TO KEEP PUMPING PRODUCT. SNAP-IN/SNAP-OUT FEATURES LOCK RESERVOIR AND REFILL TANK IN PLACE. TIME-TESTED, HEAVY-DUTY PUMP MECHANISM IS GUARANTEED FOR LIFE.

STOCK NO. GK05000

**ADVANTAGE HD PUMICIZED  
 HAND CLEANER**

CONTAINS HIGH QUALITY, FINE-GROUND, AMERICAN PUMICE TO SPEED REMOVAL OF ALL TYPES OF STUBBORN SOIL WITHOUT HARSH CHEMICALS. PREMIUM COSMETIC GRADE CLEANING AGENTS SAFELY AND EFFECTIVELY DISSOLVE GREASE, PAINTS, INKS AND MANY OTHER HARD TO REMOVE SOILS. CONTAINS A BACTERIOSTAT. FORTIFIED WITH FIVE CONDITIONERS.



STOCK NO. GK94400

**GLK-55 SOLVENT FREE  
 HAND CLEANER**



THE NEWEST ADDITION TO GENT-L-KLEEN'S LINE-UP, THE GLK-55 IS THE FIRST HAND SOAP TO BE USED WITH WATER, IT REMOVES GENERAL DIRT AND GRIME, GREASES, TAR, ETC. THIS FORMULA CONTAINS A BACTERIOSTAT AND FIVE NATURAL MOISTURIZERS. FINE PLASTIC MICROSCRUBBING

BEADS ADDED TO GLK-55 ALLOW YOU TO GENTLY CLEAN DEEPER TO REMOVE EVEN THE TOUGHEST DIRT AND GRIME.

STOCK NO. GK554400

**PUMICIZED TURBO CONDITIONER  
 CHERRY HAND CLEANER**

A PREMIUM, HEAVY DUTY LOTION HAND CLEANER. IT CONTAINS FINE-GROUND PUMICE FOR FAST AND COMPLETE REMOVAL OF GREASE, MOST INKS, TAR, ASPHALT, OILS, LUBRICANTS, PAINTS AND MORE. THIS ADVANCED CONDITIONING FORMULA INCLUDES AN ANTIMICROBIAL AGENT AND TEN SKIN CARE INGREDIENTS. 4000 ML TANK FOR USE IN GENT-L-KLEEN'S DISPENSER-MATE 5000.



STOCK NO. GK554400

**SMOOTH CITRUS LOTION**

THIS HAND CLEANER HAS THE FRESH SCENT OF NATURAL CITRUS. THIS CITRUS BASED FORMULA IS PH BALANCED, VERY EFFECTIVE AT CLEANING TOUGH SOILS, BIODEGRADABLE AND PETROLEUM SOLVENT FREE TO ADDRESS ENVIRONMENTAL CONCERNS. PREMIUM, NATURAL CITRUS CLEANING AGENT, SAFELY AND EFFECTIVELY DISSOLVES GREASE, PAINTS, INKS AND MANY OTHER HARD TO REMOVE SOILS. CONTAINS A BACTERIOSTAT. FORTIFIED WITH FIVE CONDITIONERS.



STOCK NO. GK114400

**PUMICIZED CITRUS LOTION**

THIS HAND CLEANER HAS THE FRESH SCENT OF NATURAL CITRUS WITH FINE-GROUND, AMERICAN PUMICE ADDED. THIS CITRUS BASED FORMULA IS PH BALANCED, VERY EFFECTIVE AT CLEANING TOUGH SOILS, BIODEGRADABLE AND PETROLEUM SOLVENT FREE TO ADDRESS ENVIRONMENTAL CONCERNS. PREMIUM, NATURAL CITRUS CLEANING AGENT, SAFELY AND EFFECTIVELY DISSOLVES GREASE, PAINTS, INKS AND MANY OTHER HARD TO REMOVE SOILS. CONTAINS A BACTERIOSTAT. FORTIFIED WITH FIVE CONDITIONERS.



STOCK NO. GK124400

**PREMIUM BLUE  
 HAND AND BODY SOAP**

A CONCENTRATED ECONOMICAL TO USE LIQUID SOAP THAT ELIMINATES BAR SOAP MESS. IT IS DESIGNED TO USE IN GENERAL WASHROOM SITUATIONS AND SHOWERS. IT IS PH BALANCED, LIGHTLY SCENTED WITH A PLEASANT FRAGRANCE AND BIODEGRADABLE PREMIUM BLUE CONDITIONS AS WELL. IT ALSO CONTAINS AN ANTIMICROBIAL AGENT.



STOCK NO. GK144400

**SOY BLAST HAND CLEANER**

A PREMIUM, SOY-BASED, HEAVY DUTY LOTION HAND CLEANER EFFECTIVE FOR REMOVING THE TOUGHEST SOILS. THE FORMULA IS PRODUCED USING ENVIRONMENTALLY "GREEN" INGREDIENTS MAKING IT VOC, NPE AND PETROLEUM FREE. FINE GROUND PUMICE WORKS WITH THE FORMULA TO PROVIDE FAST AND COMPLETE REMOVAL OF GREASE, MOST INKS, TAR, ASPHALT, OILS, LUBRICANTS, PAINTS AND MORE. CONTAINS AN ANTIMICROBIAL AGENT AND TEN SKIN CARE INGREDIENTS. 4000 ML TANK.



STOCK NO. GK554400

**POWER WIPES**



EACH CANISTER HAS A RESEALABLE TOP AND HAS TOWELS SATURATED WITH A SPECIAL HEAVY DUTY CLEANING SOLUTION. BEING SOLVENT-FREE, IT STILL EFFECTIVELY DISSOLVES GREASE.

STOCK NO. GK219060

**LPS HAND CLEANER TOWELS**



THE ONE-STEP WATERLESS HAND CLEANER TOWEL WITH PROVEN PUMICE PERFORMANCE DOES IT ALL. POWERFUL CLEANING AGENTS WORK TOGETHER WITH AN ABSORBENT, NON-SCRATCHING HAND CLEANING TOWEL. THE RESULT IS HANDS WHICH ARE CLEAN, PROTECTED AND RESIDUE FREE.

STOCK NO. LPS09200

**TUB-O-TOWELS CLEANERS**



90 COUNT, 10 X 12 SHEETS FOR BIG SPILLS OR MESSSES. NO WATER NECESSARY. REMOVES STAINS OTHERS WON'T, INCLUDING GREASE, TAR, INK, PAINT, PERMANENT MARKER AND OTHER HARD-TO-REMOVE SOILS. ENVIRONMENTALLY FRIENDLY AND GENTLE ON HANDS. CONTAINS LANOLIN, ALOE VERA AND VITAMIN E.

STOCK NO. GASTW90

**PROTECTIVE HAND COATINGS**



CREATE A CLEAR, PROTECTIVE BARRIER THAT ALLOWS QUICK, EASY CLEAN-UP OF DIRT, GREASE AND PAINT. 14 OZ. SKIN ARMOR FOAM AEROSOL OR 5 OZ. TUBE OF INVISIBLE GLOVE CREAM.

STOCK NO. GK51412 (SKIN ARMOR)

STOCK NO. S05215 (INVISIBLE GLOVE)

LET US HELP YOU WITH SPECIAL APPLICATION PRODUCTS. IF IT'S NOT IN THE CATALOG, IT'S UP TO US TO GET IT FOR YOU.

**GLOVES**

**COTTON GLOVES**



12 OZ. EXTRA TOUGH 100% COTTON . BLUE KNIT WRIST.

**STOCK NO. GLV014**



LONGER WEARING 8 OZ. GLOVE. 100% COTTON. BLUE KNIT WRIST.

**STOCK NO. GLV010**

**YELLOW FLEECE GLOVES**



100% COTTON. HEAVY GOLDEN FLEECE BONDED WITH INNER FLANNEL MATERIAL FOR STRENGTH. MATCHING KNIT WRIST.

**STOCK NO. GLV021**

**GRIPPER GLOVES**



"TUFF DOT" PALM & FOREFINGER. 100% COTTON FOR LONGER WEAR. KNIT WRIST.

**STOCK NO. GLV150**

**JERSEY GLOVES**



FULL SIZE 12 OZ. JERSEY. SEAL BROWN, KNIT WRIST, 100% COTTON.

**STOCK NO. GLV006**

**CHORE GLOVES**



"TURTLENECK." HEAVY NAPPED GOLDEN FLEECE ON PALM, THUMB & FOREFINGER. TURTLENECK SAFETY CUFF.

**STOCK NO. GLV020**

**KNIT GLOVES**



100% COTTON/KNIT GLOVE.

**STOCK NO. GLV250**



COTTON/POLY KNIT GLOVE. YELLOW TUFF DOTS. MEDIUM SIZE. 7 GAUGE MATERIAL.

**STOCK NO. GLV156**



COTTON/POLY KNIT GLOVE. BLACK TUFF DOTS. LARGE SIZE. 7 GAUGE MATERIAL.

**STOCK NO. GLV157**

**KNIT DOUBLE DOT GLOVE**



NATURAL WHITE COTTON/POLYESTER STRING KNIT WITH PVC DOTS ON BOTH SIDES.

**STOCK NO. GLV260 (SMALL)**  
**STOCK NO. GLV261 (LARGE)**

**STRING KNIT GLOVES**



HEAVY WEIGHT, GREY, COTTON/POLYESTER STRING KNIT.

**STOCK NO. GLV270 (SMALL)**  
**STOCK NO. GLV271 (LARGE)**

**RUBBER COATED KNIT GLOVES**



**STOCK NO. GLV169 (BLUE LARGE)**  
**STOCK NO. GLV170 (BLUE XL)**

**BLUE LATEX COATED KNIT GLOVES**



**STOCK NO. GLV165**



**GLOVES**

**QUALITY LEATHER GLOVES**  
**LEATHER PALM GLOVES**



THE HEAVY DUTY LEATHER GLOVE. GUN PATTERN WITH FULLY LINED LEATHER PALM AND THUMB. FULL LEATHER INDEX FINGER, LEATHER FINGERTIPS AND KNUCKLE STRAP. STRIPED COTTON

BACK WITH ELASTIC FOR BETTER FIT. 2-1/2" SAFETY CUFF.

**STOCK NO. GLV053**

**STOCK NO. GLV068 (FULL LEATHER BACK)**



CLUTE STYLE, PREMIUM LEATHER PALM, FLANNEL LINED, SAFETY CUFF, COTTON BACK.

**STOCK NO. GLV061 (SIZE XL)**



TG (TOP GRAIN) LEATHER PALM. QUALITY UNLINED SPLIT LEATHER. GUN CUT, SLIP-ON STYLE.

**STOCK NO. GLV075**

CLUTE STYLE, LEATHER PALM, FLANNEL LINED, BLUE KNIT WRIST, COTTON BACK.



**STOCK NO. GLV059**



SELECT SIDE SPLIT LEATHER. SAME QUALITY AS THE GLV053 WITH AN ADDITIONAL LAYER OF LEATHER COVERING THE WHOLE PALM. LONGEST WEARING LEATHER GLOVE AVAILABLE.

**STOCK NO. GLV064**

**DRIVER'S GLOVES**



FULL GRAIN LEATHER DRIVERS GLOVE.

**STOCK NO. GLV455**



PREMIUM LEATHER DRIVER GLOVES

**STOCK NO. GLV476**

**WELDER'S GLOVES**

PREMIUM QUALITY WELDERS GLOVE FEATURING SPECIAL WELDERS TANNED LEATHER. FULL FLEECE LINING FOR THE PALM AND BACK OF HAND. ONE PIECE BACK-NO SEAMS TO RUB ON BACK OF HAND. ALL MAJOR SEAMS WELDED.



**STOCK NO. GLV575**

**HI-TEMP GLOVES**



"CONO-GUARD" MITTEN. MADE WITH THE MIRACLE FIBRE "KEVLAR". HEAT-RESISTANT AND HIGHLY CUT-RESISTANT. WILL REPLACE ASBESTOS IN MOST APPLICATIONS WITH A WEAR FACTOR OF 8 TO 1. 100% KEVLAR TERRY CLOTH OUTER LAYER, FLEECE LINED.

**STOCK NO. GLV590**

**EXTRA HEAVY, HOT MILL GLOVES**



GAUNTLET STYLE. 24OZ. DOUBLE QUILTED HOT MILL, BAND TOP WITH KNUCKLE STRAP.

**STOCK NO. GLV540**

**WINTER GLOVES**  
**LEATHER PALM GLOVES**



INSULATED LEATHER PALM, THERMAL LINED, PREMIUM GRAIN PIGSKIN LEATHER PALM WITH COTTON STRIPED BACK. 3M THINSULATE INSULATION PROVIDES EXTRA WARMTH AND COMFORT. SIZE LARGE ONLY.

**STOCK NO. GLV080**



WINTER GLOVE.COMFORTABLE RED FLEECE LINING BONDED TO BROWN JERSEY, SLIP-ON STYLE, GUN CUT, 100% COTTON.

**STOCK NO. GLV016**

**DURATHERM COATED WINTER GLOVES**



RUBBER PALM COATED STRING KNIT GLOVE. JERSEY LINED. BETTER FOR COLD WEATHER USE THAN THE STANDARD RUBBER COATED GLOVE.

**STOCK NO. GLV190**

**STOCK NO. GLV191 (LARGE)**

MRS. FLINDERS DECIDED TO HAVE HER PORTRAIT PAINTED. SHE TOLD THE ARTIST, "PAINT ME WITH DIAMOND EARRINGS, A DIAMOND NECKLACE, EMERALD BRACELETS, AND A RUBY PENDANT."

"BUT YOU'RE NOT WEARING ANY OF THOSE THINGS."

"I KNOW SAID MRS. FLINDERS. "IT'S IN CASE I SHOULD DIE BEFORE MY HUSBAND. I'M SURE HE'D REMARRY RIGHT AWAY, AND I WANT HER TO GO NUTS LOOKING FOR THE JEWELRY."

### GLOVES

#### SPORTS/MECHANICS GLOVE



BLACK PALM, REINFORCED THUMB AND FINGERTIPS, KNUCKLE BAND, BLUE SPANDEX BACK, VELCRO CLOSURE.

STOCK NO. GLV675 (X-LARGE)  
STOCK NO. GLV676 (XX-LARGE)

#### PVC COATED GLOVES



COATED PVC, JERSEY LINED, 12" GAUNTLET. WING THUMB. LIQUID PROOF.

STOCK NO. GLV102  
STOCK NO. GLV125 (KNIT WRIST)

14" GAUNTLET, COATED PVC. EXTRA GRIP CRINKLE FINISH. LIQUID PROOF.



STOCK NO. GLV115



HEAVY DUTY PVC COATED GLOVE. BEST ALL AROUND GLOVE FOR HANDLING A WIDE RANGE OF ACIDS, CAUSTICS, AND SOLVENTS. OFFERS A HIGH DEGREE OF ABRASION RESISTANCE. TWO PIECE NAPPED JERSEY LINER ELIMINATES SEAMS FROM THE WORK AREA, AND INSULATES AGAINST MODERATE HEAT AND COLD. 18" LENGTH.

STOCK NO. GLV105

#### TEXTURED RUBBER GLOVES



STOCK NO. GLV175

#### SOLVEX GLOVES



EMBOSSED NON-SLIP, WET/DRY GRIP WITH HIGH TENSILE STRENGTH. CHEMICAL AND SOLVENT PROTECTION. APPLICATIONS INCLUDE KITCHEN MAINT., DEGREASING, FOOD PREP., JANITORIAL SANITARY MAINT., FLOCK COTTON LINING ABSORBS PERSPIRATION.

STOCK NO. GLV630 (SIZE 10)  
STOCK NO. GLV640 (SIZE 12)

#### INSPECTION GLOVES



FULL STRETCH NYLON . HEMMED

STOCK NO. GLV290



STRETCH NYLON. REVERSIBLE, HEMMED.

STOCK NO. GLV280

#### LATEX INSPECTION GLOVES



LIGHTLY POWDERED LATEX EXAMINATION GLOVE. NON-STERILE, SINGLE USE, AMBIDEXTROUS.

STOCK NO. GLV352 (LARGE)  
STOCK NO. GLV353 (X-LARGE)

#### LATEX INSPECTION GLOVES HEAVY DUTY



15 ML, HEAVY DUTY, POWDER FREE, LATEX EXAMINATION GLOVE. NON-STERILE, SINGLE USE, AMBIDEXTROUS. 50 GLOVES PER BOX.

STOCK NO. GLV354 (X-LARGE )

#### NITRILE GLOVES



BLUE NITRILE DISPOSABLE GLOVES. INDUSTRIAL GRADE. 4 ML. AMBIDEXTROUS.

STOCK NO. GLV370 (SMALL)  
STOCK NO. GLV372 (MEDIUM)  
STOCK NO. GLV374 (LARGE)  
STOCK NO. GLV376 (X-LARGE)  
STOCK NO. GLV391 (LARGE POWDER FREE)  
STOCK NO. GLV392 (X-LARGE POWDER FREE)

#### NITRILE GLOVES HEAVY DUTY



8 ML., HEAVY DUTY, POWDER FREE, BLUE NITRILE DISPOSABLE GLOVES. AMBIDEXTROUS. 50 GLOVES PER BOX.

STOCK NO. GLV393 (X-LARGE)

WISDOM DOESN'T NECESSARILY COME WITH AGE. SOMETIMES AGE JUST SHOWS UP ALL BY ITSELF.

--TOM WILSON

*YOUR COMPLETE SOURCE FOR INDUSTRIAL SUPPLIES*



**12 POCKET, PROFESSIONAL-STYLE FULL GRAIN LEATHER CARPENTER APRON**



THIS TOP-OF-THE-LINE 2 BAG CONSTRUCTION APRON OFFERS THE COMBINATION OF FEATURES THE PROFESSIONAL DEMANDS. A PROVEN BEST-SELLER FOR THE TRADES.

**FEATURES INCLUDE:**

- MADE OF HEAVY-DUTY, FULL GRAIN COWHIDE LEATHER
- 2 EXTRA LARGE, FLARED MAIN NAIL POCKETS, 2 MEDIUM SIZED FRONT NAIL POCKETS AND 6 SMALL TOOL POCKETS.
- A TOUGH STRAP LEATHER HAMMER LOOP ON EACH SIDE ; LEATHER TAPE POCKET FOR 16-25' TAPE RULES AND A COMBINATION SQUARE HOLSTER
- DOUBLE-STITCHED MAIN POCKETS AND EXTRA RIVET REINFORCEMENT THROUGH OUT FOR YEAR IN, YEAR OUT STRENGTH
- 2" WEB BELT WITH QUICK RELEASE BUCKLE FOR EASY FIT. FITS WAIST SIZES UP TO 48".

**STOCK NO. MN427**

**12-POCKET, PROFESSIONAL ELECTRICIANS' TOOL POUCH**



SPECIALLY DESIGNED FOR THE PROFESSIONAL ELECTRICIAN AND REPAIRMAN. OVERALL SIZE: 12" x 10".

**FEATURES INCLUDE:**

- HEAVY-DUTY, PLIABLE, SEMI-SOFT, SADDLE LEATHER
- DESIGNED FOR EASY ACCESS TO TOOLS.
- LEATHER TAPE POCKET HOLDS UP TO A 30' TAPE
- "T" CHAIN TAPE HOLDER
- QUICK RELEASE TOOL SNAP
- RIVET-REINFORCED FOR EXTRA STRENGTH

**STOCK NO. MN500**

PRAISE CAN BE YOUR MOST VALUABLE ASSET AS LONG AS YOU DON'T AIM IT AT YOURSELF.  
 --O.A. BATTISTA

**TOOL POUCHES AND ACCESSORIES**

**8-POCKET, PROFESSIONAL, FULL GRAIN LEATHER CARPENTER'S POUCH**



A POPULAR SELLER WITH CARPENTERS AND OTHER PROFESSIONALS WHO APPRECIATE FUNCTIONAL DESIGN AND RUGGED CONSTRUCTION.

**FEATURES INCLUDE:**

- HEAVY-DUTY, FULL GRAIN LEATHER
- 8-POCKET DESIGN INCLUDING: 1 LARGE MAIN POCKET, 1 MEDIUM FRONT NAIL POCKET, 6 SMALL TOOL POCKETS, 2 LEATHER HAMMER HOLDERS.
- 2 LEATHER HAMMER LOOPS ALLOW THE POUCH TO BE WORN ON THE LEFT OR RIGHT
- EXTRA RIVET REINFORCEMENT FOR ADDED STRENGTH
- WIDE TUNNEL BELT LOOP

**STOCK NO. MN823**

**3-POCKET, SUEDE LEATHER, DRY WALL POUCH**



ADDITIONAL NAIL AND TOOL CAPACITY GIVES DRY WALL HANGERS AN EXTRA MEASURE OF CONVENIENCE.

**FEATURES INCLUDE:**

- HEAVY-DUTY, SUEDE LEATHER
- DESIGNED FOR BULK STORAGE OF FASTENERS AND NAILS
- 1 LARGE AND 1 MEDIUM NAIL POCKET. PLUS 1 MEDIUM TAPE POCKET AT WAIST
- CAN BE WORN ON THE LEFT OR RIGHT AND BE COMBINED WITH OUTER ACCESSORIES
- EXTRA RIVET REINFORCEMENT FOR STRENGTH
- WIDE TUNNEL BELT LOOP

**STOCK NO. MN583**

**ADDITIONAL ITEMS AVAILABLE UPON REQUEST**



**7-POCKET, FLARED TOOL POUCH**



THIS 7-POCKET POUCH IS A POPULAR SELLER WITH PROFESSIONALS INTERESTED IN TOP VALUE.

**FEATURES INCLUDE:**

- HEAVY-DUTY, SADDLE LEATHER
- DESIGNED FOR EASY VERTICAL STORAGE AND EASY ACCESS TO TOOLS
- INCLUDES UNIQUE HOLDERS FOR: HAMMER, TAPE, MEASURING TAPE, FLASHLIGHT AND KEY
- RIVET-REINFORCED FOR EXTRA STRENGTH
- WIDE 2-3/4" TUNNEL BELT LOOP, WHICH CAN CONVERT TO BELT SLOTS.

**STOCK NO. MN603**

**MULTI-POCKET, BOX-SHAPE DRYWALL HANGERS' POUCH**



ONE OF OUR TOP-SELLING DRY-WALL POUCHES.

**FEATURES INCLUDE:**

- HEAVY-DUTY, SADDLE LEATHER
- LARGE MAIN POCKET WITH MULTIPLE TOOL POCKETS
- TAPERED DRYWALL SAW HOLDER
- STEEL HAMMER LOOP
- RIVET-REINFORCED FOR ADDED STRENGTH
- WIDE 2-3/4" TUNNEL BELT LOOP
- NO. 481L - FOR LEFT HANDERS
- NO. 481R - FOR RIGHT HANDERS

**STOCK NO. MN481**

OPPORTUNITY IS SOMETIMES HARD TO RECOGNIZE IF YOU'RE ONLY LOOKING FOR A LUCKY BREAK.

--MONTA CRANE



## TOOL POUCHES AND ACCESSORIES

### STEEL, CRADLE LOOP, HAMMER-HATCHET HOLDER



VERSATILE AND STRONG. ONE OF OUR TOP SELLING HAMMER/HATCHET HOLDERS.

FEATURES INCLUDE:

- HEAVY, TOP GRAIN SADDLE LEATHER BACK
- DOUBLE RIVET REINFORCED, NICKEL PLATED, ALL STEEL HAMMER LOOP FOR STRENGTH AND RUST RESISTANCE
- CRADLE LOOP DESIGN HOLDS HAMMER SNUGLY IN PLACE
- 2-1/4" WIDE BELT SLOTS

STOCK NO. MN439

### EXTRA CAPACITY 16'-25' TAPE RULER HOLDER

FITS MOST 3/4" WIDE BLADE TAPE RULES INCLUDING 1" WIDE 25' STANLEY TAPE.



FEATURES INCLUDE:

- HEAVY-DUTY, TOP GRAIN SADDLE LEATHER.
- EXTRA RIVET REINFORCED TAPE POCKET SECURES TAPE RULE IN PLACE WITH A PULL-THROUGH BACK, SAFETY STRAP AND SNAP.
- DIE MOLDED, ONE HAND "PUSH UP" POCKET DESIGN ASSURES EASY TAPE RULE REMOVAL.
- EXTRA WIDE 3" BELT SLOTS.

STOCK NO. MN464

### EXTRA-WIDE WORK SUSPENDERS



DESIGNED TO HOLD NAIL BAGS AND CARPENTER APRONS. SUSPENDERS LIGHTEN THE LOAD THAT NORMALLY RESTS ON HIPS AND LOWER BACK.

FEATURES INCLUDE:

- HEAVY-DUTY 2" WIDE, FULLY ADJUSTABLE, POLYPROPYLENE FRONT STRAPS FOR STRENGTH. ELASTIC, NYLON WEBBING REAR STRAPS FOR EXTRA CUSHION WHERE IT COUNTS.
- NICKEL PLATED, HEAVY-DUTY HARDWARE KEEPS TIGHT GRIP.
- ONE SIZE FITS ALL.
- COLORS: RED-RAINBOW-RED, WHITE & BLUE-DARK BLUE

STOCK NO. MN110C (RED)  
 STOCK NO. MN111 (RED, WHITE & BLUE)  
 STOCK NO. MN112 (DARK BLUE)  
 STOCK NO. MN113 (RAINBOW)

### 4-POCKET, UTILITY, BIB-STYLE APRON



A HEAVIER-DUTY VERSION FOR REALLY TOUGH JOBS. OVERALL SIZE 17" x 20-1/4".

FEATURES INCLUDE:

- 10 OZ., 100% NATURAL COTTON CANVAS.
- 4-POCKET DESIGN INCLUDING: 2 LARGE WAIST POCKETS; 2 SMALL BIB POCKETS
- BAR TACKED AT MAJOR STRESS POINTS.
- CANVAS LOOP NECK AND WAIST TIES.

STOCK NO. MNC9

### 5-POCKET, MEDIUM PRICED WAIST APRON



ONE OF OUR TOP SELLING CANVAS WAIST APRONS.

FEATURES INCLUDE:

- 10 OZ., 100% NATURAL COTTON CANVAS.
- 5-POCKET DESIGN INCLUDING: 2 LARGE FLARED POCKETS AND 3 SMALL POCKETS
- 2 WEBBED HAMMER LOOPS ON THE RIGHT AND LEFT SIDES.
- DOUBLE-STITCHED AND RIVET REINFORCED AT MAJOR STRESS POINTS TO ENSURE STRENGTH.

STOCK NO. MNC14

**ADDITIONAL ITEMS AVAILABLE UPON REQUEST**

### COTTON WEB WORK BELT



2-1/4" WIDE COTTON WEB WORK BELT. DESIGNED TO HOLD ROOFER'S HIP PADS. HEAVY-DUTY, RUST RESISTANT HARDWARE. ADJUSTS TO FIT UP TO 46" WAISTS.

STOCK NO. MN502

### 1-3/4" LEATHER WORK BELT



MADE OF STRONG TOP GRAIN LEATHER WITH BASKET WEAVE EMBOSSEMENT. RUST PROOF, NICKEL PLATED HARDWARE. BELT CUTS OFF TO FIT FROM 29" - 46" WAISTS.

STOCK NO. MN416X

### KNEE PADS



VELCRO FASTENERS FOR EASY-ON, EASY-OFF CONVENIENCE. SINGLE 1-1/2" ELASTIC STRAP IS ADJUSTABLE AND KEEPS PAD IN PLACE. CONTOURED, WATER-REPELLENT CELLULAR RUBBER.

STOCK NO. MN340

### PROFESSIONAL RUBBER KNEEPADS



THESE EXTRA TOUGH KNEE PADS STAND UP TO MOST DEMANDING PROFESSIONAL USES. TWO 3/4" WIDE ADJUSTABLE, LEATHER STRAPS PER PAD SECURE PAD COMFORTABLY TO KNEE. HEAVY-DUTY, 1" THICK CELLULAR RUBBER PAD PROVIDES COMFORT, EVEN AFTER EXTENDED WEAR. FLAT FACE FOR STABILITY.

STOCK NO. MN319

**FACE AND HEAD PROTECTION - LENS CLEANING**

**FACE SHIELD**

CROWN HEADGEAR WITH WINDOW



PROTECT THE FACE AGAINST FLYING PARTICLES, CHIPS, SPLASHING. LIGHTWEIGHT AND DURABLE. EASILY ADJUSTABLE HEADGEAR. REPLACEABLE ACETATE WINDOW.

STOCK NO. USS151

**HEAVY DUTY FACE-SHIELD WINDOW**  
 REPLACEMENT FOR ABOVE FACE SHIELD ASSY.



CLEAR ACETATE 8" x 16", .040 THICK. WINDOW ATTACHED BY STUD AND SPRING CLIP METHOD. WRAP AROUND FEATURE. LIGHTWEIGHT AND DURABLE.

STOCK NO. USS152

**GREEN HEAVY DUTY FACESHIELD WINDOW**  
 LIKE ABOVE ONLY GREEN ACETATE.

STOCK NO. USS153

**SAFETY APRONS**



**WELDER'S APRON**

24" x 42". FLAME-RESISTANT. GREEN COTTON. ADJUSTABLE NECK STRAPS

STOCK NO. EW25



**HEAVY RUBBER WORK APRON**

BLACK. CHEMICAL-RESISTANT. 35" x 45".

STOCK NO. MSPMB20045

**PROTECTIVE HELMETS**

**WITH 6-POINT SNAP LOCK SUSPENSION**



WITH 33 MM MOUNTING SLOTS FOR ATTACHMENTS OF ACCESSORIES

- ◆ 6-POINT SUSPENSION ALLOWS BETTER BALANCE AND ABSORBS IMPACT.
- ◆ LOW NAPE STRAP ELIMINATES UNWANTED SHIFTING.
- ◆ CUSHIONED BROW EFFECTIVELY ABSORBS MOISTURE.
- ◆ SLOTTED BACK BAND EASILY ADJUSTS TO FIT HEAD SIZES 6-1/2" TO 7-3/4".
- ◆ LOW PROFILE, WELL BALANCED DESIGN PROVIDES MAXIMUM COMFORT.
- ◆ ACCESSORY SLOTS ARE UNIVERSAL TO ACCOMMODATE A VARIETY OF PROTECTIVE PRODUCTS FOR THE EAR, EYE OR FACE

STOCK NO. COLOR

ES3412	RED
ES3452	YELLOW
ES3442	WHITE
ES3492	BLUE

**WITH 6-POINT RATCHETING SUSPENSION**

STOCK NO. COLOR

USS200	RED
USS201	WHITE
USS202	BLUE
USS203	YELLOW
USS205	LIME GREEN

**REPLACEMENT SNAP LOCK SUSPENSION**

STOCK NO. ES562

**REPLACEMENT RATCHET SUSPENSION**

STOCK NO. ES564

**HARDHAT SWEAT BAND**

STOCK NO. ES002

LORD, WHERE WE ARE WRONG, MAKE US WILLING TO CHANGE; WHERE WE ARE RIGHT, MAKE US EASY TO LIVE WITH.  
 --REV. PETER MARSHALL

**ECONOMICAL LENS CLEANING STATION**



- ◆ NON-ABRASIVE WIPES
- ◆ SPRAY BOTTLE CLEANING SOLUTION

STOCK NO. MSP600SC

**PRE-MOISTENED LENS CLEANING TISSUES**



NON-SILICONE BASED TISSUES ARE INDIVIDUALLY PACKAGED. CONVENIENT SIZE FITS IN OFFICE, TOOLBOXES, TRUCKS AND WORKSTATIONS. 100 TISSUES PER BOX.

STOCK NO. GR29062

*THIS IS A COMPREHENSIVE CATALOG OF OUR MAJOR LINES AND SERVICES, BUT IT DOES NOT SHOW ALL AVAILABLE PRODUCT LINES. IF THERE IS SOMETHING YOU NEED THAT IS NOT SHOWN, WE EITHER CARRY IT OR CAN GET IT. PLEASE CALL US FOR INFORMATION.*

### FIRST AID

#### FIRST AID KITS



KITS INCLUDE A FULL, BALANCED ASSORTMENT OF FIRST QUALITY, FIRST AID SUPPLIES AND ARE EQUIPPED FOR WALL MOUNTING. OUR METAL KITS COMPLY WITH OSHA REQUIREMENTS, AND ARE SO MARKED.

##### 25 PERSON CONTRACTORS KIT

GREAT FOR HOMES, OFFICES, STORES, SUMMER COTTAGES, RESTAURANTS AND IN PLANTS. SIZE: 6-1/2 x 9-1/2 x 2-3/4.

**STOCK NO. PK6084** (PLASTIC CASE)  
**STOCK NO. PK6086** (STEEL CASE)

##### 50 PERSON INDUSTRIAL KIT

GREAT FOR PLANTS EMPLOYING 25 TO 50 PERSONS, TRUCKS, BUSES, MACHINE ROOMS, AND CAMPS. 9-1/2 x 13-1/2 x 2-3/4. WT. 3-1/4 LBS.

**STOCK NO. PK6450** (STEEL CASE)

#### INDUSTRIAL FIRST AID STATION



GREAT FOR LARGE OFFICES, WAREHOUSES, DISTRIBUTION CENTERS AND FACTORIES.

**STOCK NO. PK6175** (STEEL CASE)

##### REPLACEMENT ITEMS FOR FIRST AID KITS

ANTISEPTIC WIPES **STOCK NO. ES171**  
BOX OF 100

BZK CHLORIDE **STOCK NO. PK12180**  
ANTISEPTIC WIPES  
BOX OF 50

FIRST AID CREAM **STOCK NO. ES2011**  
BOX OF 12

STING RELIEF PADS **STOCK NO. ES167**  
SOLD INDIVIDUALLY

ADHESIVE STRIPS, **STOCK NO. ES164X**  
1" x 3", BOX OF 100

BUTTERFLY BANDAGES. **STOCK NO. PK1012**  
BOX OF 16

ADHESIVE TAPE **STOCK NO. PK8050**  
1/2 x 5YD.

ANTISEPTIC SWABS **STOCK NO. PK10007**  
BOX OF 10

EYE FLUSH **STOCK NO. PK7008**  
1 FL. OZ. BOTTLE

ASPIRIN **STOCK NO. PK20150**  
325 MG PER TABLET  
50 PACKETS OF 2 TABLETS

NON-ASPIRIN **STOCK NO. PK20450**  
ACETAMINOPHEN 500 MG PER TABLET  
50 PACKETS OF 2 TABLETS

IBUPROFEN **STOCK NO. PK20550**  
200 MG PER TABLET  
50 PACKETS OF 2 TABLETS

COLD AND SINUS **STOCK NO. PK20650ADV**  
200 MG PER TABLET  
125 PACKETS OF 2 TABLETS

ANTACID TABLET **STOCK NO. PK20750**  
50 PACKETS OF 2 TABLETS

**MANY OTHER  
REPLACEMENT ITEMS  
ARE AVAILABLE  
FOR FIRST AID KITS.**

**QUALITY  
PRODUCTS,  
FAIR  
AND  
COMPETITIVE  
PRICES,  
AND  
EXCELLENT  
SERVICE  
IS  
OUR  
REPUTATION**

#### SAVE TIME AND MONEY

**TO SAVE OUR CUSTOMERS  
THE DELAY  
AND BOTHER  
OF HUNTING  
THROUGH MANY SOURCES  
OF SUPPLY,  
WE CAN FURNISH  
MANY ITEMS  
NOT LISTED  
IN THIS  
CATALOG**

**EYE AND WELDING PROTECTION**

**DELUXE COVER VISITOR SPECTACLE**



CLEAR FRAME AND LENS. DOUBLE CONSTRUCTION, SIDESHIELD MOLDED IN FRAME DESIGN. LIGHT DUTY IMPACT PROTECTION FOR THE EYES FROM MINOR IMPACT HAZARDS WHEN USED ON THE FARM, IN THE HOME AND SHOP. FITS OVER PERSONAL GLASSES. ENGINEERED WITH SCRATCH RESISTANT LENS.

**STOCK NO. SPECS3 CLEAR**

**CLIP-ON CLEAR PLASTIC SAFETY SIDE SHIELDS FOR PRESCRIPTION GLASSES**



STOCK NO.	DESCRIPTION
ES017	HARD PLASTIC CLIP ON
MSP93460	SOFT PLASTIC SLIP ON

**DELUXE HEAVY DUTY PROTECTIVE GOGGLE- IMPACT PROTECTION**



VINYL FRAME, CLEAR IMPACT RESISTANT LENS. AIRFLOW VENTILATION, ADJUSTABLE ELASTIC HEADBAND. MEETS ANSI Z871 SPECIFICATIONS AND SEI CERTIFIED. PROVIDES HEAVY DUTY IMPACT PROTECTION FOR THE EYES FROM FLYING OBJECTS. CAN BE WORN OVER REGULAR GLASSES.

**STOCK NO. USS015**

WE CARE ABOUT YOUR SAFETY. IF THERE IS SOMETHING YOU ARE LOOKING FOR BUT DON'T SEE, GIVE US A CALL AND WE WILL TRY OUR BEST TO MAKE IT AVAILABLE!!

**WELDERS GOGGLES**



SOFT FRAME FLEXIBLE VINYL WITH 50mm PLASTIC WELDING LENSES. WELL VENTILATED, COMFORTABLE. LENSES ARE REPLACEABLE. WILL FIT OVER PRESCRIPTION EYE WEAR. SHADE #5 LENS.

**STOCK NO. USS170**



SOFT FRAME FLEXIBLE VINYL WITH 2" x 4-1/4" HARDENED WELDING LENS IN HINGED FRAME FOR LIFT-UP POSITION. WITH CLEAR POLYCARBONATE LENS FOR VIEWING PROTECTION WHEN IN LIFT-UP POSITION. SIX VENTILATION PORTS FOR MAXIMUM VENTILATION. LENSES ARE REPLACEABLE. SHADE #5 LENS.

**STOCK NO. USS172**



SOFT FRAME FLEXIBLE VINYL WITH 2" x 4-1/4" HARDENED WELDING LENS. LENSES ARE REPLACEABLE. SIX VENTILATION PORTS FOR MAXIMUM VENTILATION. WILL FIT OVER PRESCRIPTION EYE WEAR. SHADE #5 LENS.

**STOCK NO. USS171**

**FIBERGLASS CURVED CHIN WELDING HELMET W/ PLATES - LIFT FRONT MODEL**



COMES WITH 2" x 4-1/4" WELDER'S PLATE -SHADE #10 AND A 2" x 4-1/4" POLYCARBONATE BACK-UP PROTECTIVE PLATE. MEETS ANSI Z87.1 SPECIFICATIONS.

**STOCK NO. USS075**

**REPLACEMENT HEADGEAR STOCK NO. USS078**

**FIBERGLASS CURVED CHIN WELDING HELMET W/ WIDE-VISION PLATE, STATIONARY FRONT MODEL**



FIBERGLASS HEAVY DUTY SHELL RESISTS MOISTURE, HEAT, IMPACT AND WELDING SPATTER. RATCHET HEADBAND ADJUSTMENT. EXTRA WIDE VISION PLATE FOR GREATER LATERAL AND PANORAMIC VIEWING. COMES WITH A 4-1/2" x 5-1/4" GLASS WELDERS PLATE, SHADE #10. EXTRA DURABLE, NON-FLAMMABLE AND EXCELLENT SHAPE STABILITY. MEETS ANSI SPECIFICATIONS.

**STOCK NO. USS077**

**REPLACEMENT HEADGEAR STOCK NO. USS078**

**SOLAR POWERED AUTO DARKENING ULTRA LIGHT WELDING HELMET**



COMES WITH 2" x 4-1/4", SOLAR POWERED AUTO DARKENING WELDER'S PLATE -SHADE #10. ULTRA LIGHT WELDING HELMET OFFERS A HIGH LEVEL OF DURABILITY BY FEATURING A MOLDED WINDOW. MEETS ANSI Z87.1 SPECIFICATIONS

**STOCK NO. USS079**

**REPLACEMENT LENSES & PLATES**

2" x 4-1/4" WELDING LENS			
STOCK NO.	SHADE	STOCK NO.	SHADE
ES0604	#4	ES0609	#9
ES0605	#5	ES06010	#10
ES0606	#6	ES06011	#11
ES0608	#8	ES06012	#12

ES064	2" x 4-1/4	CLEAR GLASS LENS COVER
ES067	2" x 4-1/4	CLEAR PLASTIC LENS COVER

2" ROUND WELDING LENS	
STOCK NO.	SHADE
ES0744	#4
ES0745	#5

**ES071 2" CLEAR GLASS LENS**

4-1/2" x 5-1/4" WELDING LENS			
STOCK NO.	SHADE	STOCK NO.	SHADE
ES0616	#6	ES06110	#10
ES0618	#8	ES06111	#11
ES0619	#9	ES06112	#12

**USS086 4-1/2" x 5-1/4" CLEAR PLASTIC LENS**

### EYE PROTECTION

#### VANGARD



RIVETED SIDESHIELDS GIVE PERMANENT PROTECTION AGAINST SIDE IMPACT

TEMPLES CAN BE EASILY ADJUSTED FOR BEST FIT

HARD COATED 58MM LENSES BLOCK 99.9% OF UV LIGHT, AND CAN BE REPLACED IF DAMAGED

STOCK NO.	DESCRIPTION
TRES3211	BLACK FRAME/CLEAR LENS

#### SEVILLE



VIRTUALLY DISAPPEARS FROM SIGHT WHILE WORN

5-STOP ADJUSTABLE SIDEARMS ASSURE INDIVIDUAL FIT

SOFT NOSE PAD DISTRIBUTES CONTACT EVENLY

DURAMIDE FRAME IS SUPER FLEXIBLE AND STRONG

SWEEPING 7-BASE CURVE LENS PROTECTS FROM TEMPLE TO TEMPLE

STOCK NO.	DESCRIPTION
TRES8811BK	METALLIC GRAY FRAME/CLEAR LENS
TRES8813BK	METALLIC GRAY FRAME/SMOKE LENS

#### FOX



ULTIMATE LIGHTWEIGHT SAFETY SPECTACLE - ONLY 0.90OZ.

INTEGRATE LENS DESIGN PROVIDING EXCELLENT TOP/SIDE PROTECTION.

VERILLIUM AEROSPACE POLYMER LENSES.

HARD COATED LENS AS STANDARD.

EXCELLENT FOR INDUSTRIAL SAFETY AND LEISURE OCCASIONS.

STOCK NO.	DESCRIPTION
TRES3811	CLEAR FRAME & LENS JOINED
TRES3825	BLUE MULTI MIRROR FRAME & LENS

OTHER LENS OPTIONS & SHADES AVAILABLE UPON REQUEST

**CALL AND LET US SHOW YOU OUR LINE OF FASHIONABLE AND FUNCTIONAL STYLES.**

#### SHARK



LIGHTWEIGHT FRAME IS SUPER STRONG FOR EXTRA DURABILITY ON THE JOB

MOLDED BROW GUARD AND LARGE SIDESHIELDS PROTECT TOTAL EYE AREA

LARGE 58MM LENS IS HARD COATED AND BLOCKS 99.9% OF HARMFUL UV RAYS

STOCK NO.	DESCRIPTION
TRES9550	METALLIC GRAY FRAME/SMOKE LENS (SHIELDS FROM ACETYLENE BURNING AND WELDING FLASH)

#### PREVUE



MATTE BLACK NYLON FRAME WEIGHS JUST 1.5 OUNCES FOR PROPER FIT AND COMFORT

LARGE LOCK-ON SIDESHIELDS PROTECT AGAINST LATERAL IMPACT

SUPER-SIZED ONE PIECE LENS IS ANTI-SCRATCH COATED AND CAN BE CHANGED IF DAMAGED

ALL LENS COLORS PROVIDE FULL ULTRA-VIOLET PROTECTION

STOCK NO.	DESCRIPTION
TRESL75C	CLEAR REPLACEMENT LENS
TRES7513	SMOKE LENS AND SIDESHIELDS
TRESL75S	SMOKE REPLACEMENT LENS
TRES7519	YELLOW LENS & CLEAR SIDESHIELDS
L75Y	YELLOW REPLACEMENT LENS

#### EXPO



INTEGRAL LENS SYSTEM GIVES FULL RADIUS OF EYE PROTECTION

EXTRA-LIGHT NYLON FRAME IS FLEXIBLE AND TOUGH ON THE JOB

5-STOP ADJUSTABLE SIDEARMS FIT MOST HEAD SIZES WITH EASE

ANTI-SCRATCH LENS BLOCKS 99.9% OF HARMFUL ULTRA-VIOLET AND CAN BE REPLACED IF DAMAGED

STOCK NO.	DESCRIPTION
TRES9511FSH	BLACK FRAME/CLEAR LENS
TRESL95C	CLEAR REPLACEMENT LENS
TRES9513BK	GLOSS BLACK FRAME/SMOKE LENS

#### DEWALT PROTECTOR



RUBBER TIPPED TEMPLES FOR A SECURE, COMFORTABLE FIT.

DISTORTION FREE LENS.

WEIGHS LESS THAN 1 OUNCE WHICH PROVIDES ALL DAY COMFORT.

TOUGH, POLYCARBONATE LENS WHICH ARE IMPACT RESISTANT AND 99.9% UV PROTECTION.

STOCK NO.	DESCRIPTION
DEWDPG542	BLACK FRAME/SMOKE LENS

#### DEWALT VENTILATOR



FULL "WRAPAROUND", RUGGED FRAME DESIGN WHICH FITS SECURELY TO PROVIDE EXCELLENT PROTECTION.

RUBBER TIPPED TEMPLES TO KEEP GLASS SECURELY IN PLACE. NON-SLIP NOSE PIECE PROVIDES MAXIMUM ALL DAY COMFORT.

TOUGH, POLYCARBONATE LENS WHICH ARE IMPACT RESISTANT AND 99.9% UV PROTECTION.

DISTORTION FREE LENS.

STOCK NO.	DESCRIPTION
DEWDPG567	SILVER FRAME/BLUE MIRROR LENS

#### DEWALT REINFORCER



HANDGRIP PATTERN ON TEMPLE IS ERGONOMICALLY POSITIONED FOR A SECURE GRIP.

NON-SLIP NOSEPIECE PROVIDES MAXIMUM ALL DAY COMFORT.

CUSHIONED, NON-SLIP TEMPLE PADS PROVIDE SUPERIOR COMFORT AND GRIP.

TOUGH, POLYCARBONATE LENS WHICH ARE IMPACT RESISTANT AND 99.9% UV PROTECTION.

DISTORTION FREE LENS.

STOCK NO.	DESCRIPTION
DEWDPG586	BLACK FRAME/FIRE MIRROR LENS

#### NECK CORDS



STOCK NO.	DESCRIPTION
RADNCBLUE	BLUE CORD
RADNCRED	RED CORD
RADNCWHITE	WHITE CORD



**RESPIRATORY PROTECTION**

**3M BRAND NON-TOXIC PARTICLE MASKS**



LOW COST SOLUTION TO A DUSTY PROBLEM. PROVIDES DEPENDABLE PROTECTION AGAINST NON-TOXIC DUSTS, POWDERS, POLLENS AND AIRBORNE IRRITANTS. LIGHTWEIGHT, CONTOUR FITTING, EASY BREATHING/SPEAKING, CLEAR VISION, LOW PROFILE DESIGN.

**STOCK NO. AP6985**      **PACKAGED: 50/BOX**

**NOTE: NOT FOR HAZARDOUS PARTICULATES OR USE IN SPRAY PAINTING.**

**3M DUST/MIST MASK**



HEAVY DUTY W/STRAPS. PROTECTION FROM DUSTS FROM PROCESSING MINERALS, COAL, IRON ORE, COTTON, FLOUR AND OTHER SUBSTANCES. ALSO, MISTS FROM SPRAYS THAT DO NOT PRODUCE HARMFUL VAPORS.

**STOCK NO. 3M8210**      **PACKAGED: 20/BOX**

**3M PARTICULATE RESPIRATOR N95**



USE FOR PARTICLES SUCH AS THOSE FROM GRINDING, SANDING, SWEEPING, SAWING, BAGGING, OR PROCESSING MINERALS, COAL, IRON ORE, FLOUR, METAL, WOOD, POLLEN, AND CERTAIN OTHER SUBSTANCES. COMFORT STRAPS, ADJUSTABLE M-NOSECLIP, SOFT INNER SHELL WHICH IS SOFT AGAINST THE FACE. PATENTED FILTER MEDIA. 3M COOL FLOW EXHALATION VALVE FOR HEAT AND HUMIDITY REDUCTION IN RESPIRATOR.

**STOCK NO. 3M8511**      **PACKAGED: 10/BOX**

**3M HEAVY DUTY DUST/MIST MASK**



FEATURES THE COMFORTABLE M-NOSE CLIP FOR A GOOD FIT AND THE COOL FLOW EXHALATION VALVE FOR HEAT AND MOISTURE REDUCTION. FACE SEAL PROVIDES A SECURE COMFORTABLE FIT.

**STOCK NO. 3M8271**      **PACKAGED: 10/BOX**

**MULTI-PURPOSE "7-IN-1" PAINT AND**



**PESTICIDE HALF MASK RESPIRATOR**  
AIR PURIFYING RESPIRATOR WITH CARTRIDGE AND FILTER ASSEMBLY. LIGHT THERMOPLASTIC-ELASTOMER FACE PIECE CONFORMS COMFORTABLY TO THE FACE. EASY TO BREATHE THROUGH. SUPERB SEALING QUALITIES. EASILY ASSEMBLED AND CLEANED. CAN BE WORN WITH OTHER PERSONAL PROTECTIVE PRODUCTS. 7-IN-1 FUME FILTER OFFERS SUBSTANTIAL COST SAVINGS. ONE FUME FILTER REPLACES 7 OTHER CARTRIDGES/FILTERS.

PROTECTS AGAINST PAINT, LACQUER & ENAMEL MISTS, DUSTS, METAL FUMES AND MISTS, PESTICIDES, RADON DAUGHTERS AND ORGANIC VAPORS.

PERFECT FOR GARDENERS, FARMERS, PAINTERS AND AUTO BODY SHOPS, AND BOAT OWNERS.

INSTRUCTION SHEET OUTLINES THE APPLICATIONS AND LIMITATIONS IN EACH PACKAGE. NIOSH/MSHA APPROVED.

**STOCK NO. USS035**

**MORE ITEMS AVAILABLE  
UPON REQUEST**

**REPLACEMENT RESPIRATOR CARTRIDGES**



ORGANIC VAPOR CARTRIDGE USED FOR LACQUER & ENAMEL PAINTS, WELDING FUMES (NOT GALVANIZED OR STAINLESS), PESTICIDES, DUSTS, NON-OIL MISTS, AND RADON DAUGHTERS.

**STOCK NO. USS045**



WELDING FUMES CARTRIDGE. USED FOR WELDING FUMES FROM STAINLESS AND GALVANIZED, LEAD, ASBESTOS, CADMIUM, RADON DAUGHTERS, AND RADIO-NUCLIDES. TAKES A SPECIAL PRE-FILTER AND RING.

**STOCK NO. USS047**



STOCK NO.	BOX/QTY.	DESCRIPTION
USS055	6	PRE-FILTER (USED W/USS045)
USS056	1	PRE-FILTER CAP

**WE ARE CONSTANTLY  
UPDATING AND ADDING  
TO OUR INVENTORY.  
IF THERE IS AN ITEM YOU  
CAN'T FIND,  
LET US KNOW.  
WE WILL DO WHAT IT  
TAKES TO ACQUIRE THE  
ITEM FOR YOU!**

**HEARING PROTECTION**

**TRI-FIT HEARING PROTECTOR**



STRONG, PLASTIC DOMES, RUGGED STEEL HEADBAND, FOAM EAR SEALS. ADJUSTABLE CUPS FOR PROPER FITTING CONTOUR. ADJUSTABLE HEADBAND CAN BE ROTATED AND WORN OVER OR BEHIND THE HEAD OR UNDER THE CHIN.

PROVIDES ATTENUATION AGAINST HARMFUL NOISE. NOISE REDUCTION RATING OF 20-24 DECIBELS WHEN USED AS DIRECTED. PROTECTS HEARING FROM EXCESSIVE NOISE OF POWER TOOLS, CHAIN SAWS, TRACTORS, RIFLES AND OTHER LOUD NOISES. ATTENUATION TESTED IN ACCORDANCE WITH ANSI SPECIFICATIONS.

**STOCK NO. ES510**

REPLACEMENT EAR COVERS  
**STOCK NO. ES113**

**EAR PLUGS**

POPULAR TYPE YELLOW FOAM EAR PLUGS, ROLL IN HAND AND INSERT. PERMITS CONVERSATIONAL NOISE LEVELS. EXTREMELY COMFORTABLE, ECONOMICAL PROTECTION FOR INDUSTRIAL ENVIRONMENTS.

**STOCK NO. DESCRIPTION**



**QT02 DISPOSABLE FOAM EARPLUG**



**QT03 MOLDEX EARPLUG**



**QT04 MOLDEX EARPLUG W/ CORD**



**QT05 EAR340-4004 - EARPLUG W/ CORD**



**QT06 SOFT PLASTIC EAR PODS W/ CORD**

INNOVATIVE, SIMPLE TO USE DESIGN WITH ULTRA SOFT TIP. FOAM SOFTENS AND BECOMES MORE COMFORTABLE THE LONGER PLUGS ARE WORN. BLUE STEM ALLOWS FOR HYGIENIC INSERTION AND REMOVAL.

**QT08 PUSH-IN EARPLUG.**

**PROTECTIVE CLOTHING**

**INDUSTRIAL P.V.C. RAINSUITS**



WELL CONSTRUCTED HIGH VISIBILITY SAFETY YELLOW RAINSUITS. OVERSIZED FOR COMFORT, 100% WATERPROOF, ENTIRELY NON-CONDUCTIVE AND CONSTRUCTED OF 35MM PVC BONDED TO POLYESTER.

HEAVY DUTY - 3 PC. RAINUIT  
FEATURES: A STRONG NYLON BOND BETWEEN TWO LAYERS OF PVC. ABRASION AND TEAR RESISTANT. DOUBLE STITCHED SEAMS. 32" JACKET WITH CORDUROY COLLAR. 1-PC BIB OVERALLS WITH SUSPENDERS.

**STOCK NO. SIZE**

<b>HGRW201S</b>	S
<b>HA9040M</b>	M
<b>HA9040L</b>	L
<b>HA9040XL</b>	XL
<b>HA9040XXL</b>	XXL
<b>HA9040XXXL</b>	XXXL

**2-PIECE P.V.C. RAINCOATS**



**STOCK NO. SIZE**

<b>HA9020L</b>	L
<b>HA9020XL</b>	XL
<b>HA9020XXL</b>	XXL
<b>HA9020XXXL</b>	XXXL

**ADDITIONAL WEATHER PROTECTION GEAR AVAILABLE UPON REQUEST**

**WINTER LINERS**



GIVES PROTECTION FROM THE WIND AND COLD TO WORKERS WHO HAVE TO WEAR HARDHATS. GREEN, EXTRA HEAVY TRIPLE PLY QUILTED FOR THE COLDEST WEATHER. ADJUSTABLE CHIN STRAP. ALL LINERS AVAILABLE WITH VELCRO FASTENER.

**STOCK NO. HG6000**

BLUE ALASKAN CAPE LINER. BLUE TWILL WITH SHEEPSKIN-LIKE LINING. SHELL AND BINDING ARE FLAME RETARDANT UNTIL WASHED. EAR POCKETS, SNUG FOREHEAD AND REFLECTIVE STRIPS.



**STOCK NO. UASRH11W**



KNIT HARD HAT LINER, 100% POLYESTER STRETCH LINER DESIGNED TO WARM YOUR HEAD AND EARS. FITS 95% OF ALL STANDARD HARD HATS.

**STOCK NO. UASRH5WB**

ORANGE KNIT LINER DESIGNED TO KEEP YOUR EARS AND HEAD WARM. STRETCH LINER FITS ALMOST ALL HARD HATS.



**STOCK NO. UASRH39W**

**SWEATBAND**



FOAM BAND. ELASTIC HEADSTRAP. 1-3/4" WIDE x 8-1/2" LONG x 3/16" THICK.

**STOCK NO. SWS**

**WE STOCK OVER 30,000 INVENTORY ITEMS. WE ARE CONSTANTLY ADDING TO OUR PRODUCT LINES TO SUIT YOUR APPLICATIONS. IF YOU DON'T SEE IT IN OUR CATALOG, CALL US. WE WILL DO EVERYTHING TO ACCOMMODATE YOUR NEEDS.**

**PROTECTIVE CLOTHING**

**17" SLUSH BOOTS**



17" RUBBER LEGGING OVERSHOE BOOT. FULL CUT FOR EASY FIT. FULLY LINED WITH EXTRA-WIDE ADJUSTABLE STRAP WITH BUCKLE ON TOP. HEAVY CLEATED SOLE.

AVAILABLE SIZE 6 TO 18

STOCK NO.	SIZE
RB00	8
RB01	9
RB02	10
RB03	11
RB04	12
RB05	13
RB06	14
RB07	15
RB08	16
RB09	17
RB091	18

**5-BUCKLE BOOT**



HEAVY DUTY 5 BUCKLE RUBBER OVER SHOE BOOT WITH WIDE LAST. MADE FROM PREMIUM GRADE RUBBER. OZONE RESISTANT. COTTON LINING SELF-DRAINING GUSSET- RIBBED SOLE. 14" HIGH. COLOR - BLACK.

STOCK NO.	SIZE
HG5B9	9
HG5B10	10
HG5B11	11
HG5B12	12
HG5B13	13
HG5B14	14
HG5B15	15

YOUR SOURCE  
 FOR  
 INDUSTRIAL  
 SUPPLIES

**BASIC PROTECTION COVERALLS**



**DISPOSABLE**

EFFECTIVE IN FILTERING OUT MANY PARTICLES, INCLUDING ASBESTOS. GENEROUS CUT. DESIGNED FOR ECONOMICAL, GOOD PROTECTION FOR SHORT WORKSHIFTS. SIMILAR TO TYVEK. WHITE.

STOCK NO.	SIZE
WC3800L	LARGE
WC3800XL	X-LARGE
WC3800XXL	XX-LARGE
WC3800XXXL	XXX-LARGE

**DISPOSABLE BOOT COVERS**



WITH ELASTIC TOP. BOOT COVERS MAY NOT PROVIDE TRACTION ON SLIPPERY FLOORS. WHITE.

STOCK NO. WC3713

ADDITIONAL SAFETY PROTECTION GEAR  
 AVAILABLE UPON REQUEST



**DENIM APRON**



12 OZ. BLUE DENIM. FOUR METAL GROMMETS. SERGED EDGES. TWO SECTION BIB POCKET. SIZE 27" x 36"

STOCK NO. HGAD100

**METATARSAL GUARD**



STOCK NO. EWS800

OTHER FOOT GUARDS  
 AVAILABLE UPON REQUEST

**WE ARE CONSTANTLY  
 UPDATING AND ADDING  
 TO OUR INVENTORY.  
 IF THERE IS AN ITEM YOU  
 CAN'T FIND,  
 LET US KNOW.  
 WE WILL DO WHAT IT  
 TAKES TO ACQUIRE THE  
 ITEM FOR YOU!**

### SHOP SAFETY PRODUCTS

#### PENNANTS



STOCK NO.	DESCRIPTION
SAM028	60' RED PENNANT ON STRING

#### HAZARD STRIPE TAPE



STOCK NO.	DESCRIPTION
NMT20236	2" x 30YD. YELLOW AND BLACK
NMT20318	2" x 30YD. RED AND WHITE

#### CONSPICUITY TAPE



DESIGNED TO MARK THE SIDE AND REAR PERIMETER OF TRUCKS AND TRAILERS FOR ENHANCED VISIBILITY AND DETECTION. GUARANTEED TO MEET OR EXCEED ALL NHTSA REQUIREMENTS. CAN BE SEEN AT ANGLES WELL BEYOND 45° FROM PERPENDICULAR.

STOCK NO.	DESCRIPTION
3M67535	2" x 150' RED AND WHITE

**STOP ON IN TO FIND ALL THOSE  
HARD TO FIND ITEMS**

#### SAFETY TRED

GUARD AGAINST DANGEROUS  
FALLS OR SLIPPING



PRESSURE SENSITIVE NON-SKID MATERIAL REDUCES HAZARDS QUICKLY AND ECONOMICALLY IN VARIOUS AREAS INCLUDING: FLOORS WHERE SLIPPERY CONDITIONS PREVAIL, STAIRS AND LADDER TREADS, RAMPS- DOCK LIFTS & FLOORS AND STEPPING AREAS OF VEHICLES SUCH AS BUSES, VANS & TRUCKS. SAFETY TRED IS A SPECIALLY MADE ABRASIVE SURFACE WATERPROOF MATERIAL.

ROLLS: COLOR BLACK  
LENGTH: 60 FEET PER ROLL.

STOCK NO.	WIDTH	LENGTH
ME71098	2" x	60'
ME71099	4" x	60'

#### HARNESSES AND SAFETY BELTS

##### HARNESSES SIZE CHART

SIZE	WAIST SIZE	
	INCHES	CENTIMETERS
XS	28-36	70-90
S	32-40	80-100
M	36-44	90-110
L	40-48	100-120
XL	44-52	110-130
2XL	48-56	120-140
3XL	52-60	130-150

NOTE: THESE ITEMS ARE WORN OVER CLOTHING, AND WAIST SIZES ARE AT THE NAVEL. NOT ALL HARNESSES ARE AVAILABLE IN ALL SIZES.

#### 900 SERIES



THE 900 SERIES BODY HARNESSES IS A TRADITIONAL "TOWER" STYLE. IT FEATURES NYLON WEB CONSTRUCTION, DROP FORGED TONGUE BUCKLES, REINFORCED WAIST BELT WITH SEWN IN BACK PAD. THE 900 SERIES IS THE HEAVY-DUTY, RUGGED STYLE, PREFERRED BY MANY.

STOCK NO.	SIZE
9001DXS	EXTRA SMALL
ELK9001DS	SMALL
ELK9001DM	MEDIUM
ELK9001DL	LARGE
ELK9001DXL	EXTRA LARGE

#### FREEDOM SERIES



FREEDOM HARNESSES ARE MADE OF POLYESTER WEBBING, AND USE STATE-OF-THE-ART PARACHUTE-TYPE MATING BUCKLES. THEY FEATURE A SLIDING BACK D-RING, FULL STRENGTH CHEST STRAP, AND A VERY HIGH STRENGTH TO WEIGHT RATIO. THEY ARE LIGHTWEIGHT, DESIGNED FOR ALL DAY COMFORT, AND MEET ALL EXISTING AND PROPOSED ANSI STANDARDS FOR FALL PROTECTION.

STOCK NO.	SIZE
ELK55104	LARGE TO EXTRA LARGE

#### LANYARD

USED FOR FALL ARREST ONLY



STOCK NO.	DESCRIPTION
ELK706	WITHOUT ABSORBER
ELKZ706	WITH ABSORBER

#### LIFTER'S BELT



WIDE 5" SPAN FOR MAXIMUM COMFORT. SECONDARY LOCKING STRAP. WINGED, TAPERED DESIGN KEEPS BELT PROPERLY POSITIONED BETWEEN HIPS AND RIBS. STRONG, ADJUSTABLE VELCRO FASTENER.

STOCK NO.	DESCRIPTION	SIZE
MN77505	X-SMALL	23"-31"
MN77515	SMALL	28"-36"
MN77525	MEDIUM	33"-41"
MN77535	LARGE	38"-46"
77545	X-LARGE	43"-51"

#### LIFTER'S SUPPORT



SMOOTH GLIDE ADJUSTABLE CLIPS. 1-1/2" EXTRA WIDE SUPPORT ELASTIC SUSPENDERS. EASY ADJUST ELASTIC OUTER PANELS FOR ADDED LOWER BACK SUPPORT.

STOCK NO.	DESCRIPTION
MN74505	X-SMALL
CARHVDS	SMALL
CARHVDM	MEDIUM
CARHVDL	LARGE
CARHVDX	X-LARGE

**ROAD AND SHOP SAFETY PRODUCTS**

**REFLEX REFLECTORS**



ACRYLIC, PLASTIC BODY. 3-1/4" DIA. WITH 3/16" CENTER MOUNT HOLE.

STOCK NO.	DESCRIPTION
SAM010	RED
SAM011	AMBER

**BARRICADE & HI-VISIBILITY TAPE**

IDEAL FOR SECTIONING OFF HAZARDOUS AREAS AND AIDING TRAFFIC CONTROL AROUND WORK-SITES.



**BARRIER TAPE**  
ROLLS OF BRIGHT YELLOW PLASTIC TAPE PRINTED "CAUTION" ALONG ENTIRE ROLL.

DESCRIPTION	STOCK NO.
3" x 300' ROLL	IR66200
3" x 1000' ROLL	SAM060

**HI-VISIBILITY TAPE**



1-3/16" x 150' LONG ROLLS OF FLUORESCENT VINYL-COATED NYLON TAPE. NON-ADHESIVE.

STOCK NO.	COLOR
IR65601	FLUORESCENT RED
IR65602	FLUORESCENT ORANGE
IR65603	FLUORESCENT PINK
IR65604	FLUORESCENT LIME

YOUR ONE-  
STOP SOURCE  
FOR  
INDUSTRIAL  
SUPPLIES

**SAFETY SIGNS**

ADHESIVE (P) - PERMANENT PRESSURE SENSITIVE ADHESIVE FOR INDOOR OR OUTDOOR USE. PEEL OFF BACKING AND APPLY TO CLEAN, SMOOTH, DRY SURFACE.

COMPLIANCE SIGNS MEET OSHA SPECIFICATIONS: 7" x 10" PLASTIC LAMICODE SAFETY SIGN.

PLASTIC (R) - .030 THICK - RIGID PLASTIC RIGID PLASTIC SIGNS -RESIST RUST, WEATHERING, TEARING, FADING, CHIPPING, CHEMICALS, AND ELECTRICAL CONDUCTIVITY. NO SHARP EDGES OR CORNERS. COMPLIANCE SIGNS HELP MEET OSHA SPECIFICATIONS.

OSHA HEADINGS: DANGER (RED) - CAUTION (YELLOW) - SAFETY FIRST (GREEN) - NOTICE (BLUE) - ADMITTANCE (BROWN) - INFORMATION - (RED & WHITE)



STOCK NO.	SIZE	TYPE
NMAS45	3-1/2" x 11"	PLASTIC



NMAS82	3-1/2" x 11"	PLASTIC
--------	--------------	---------



NMC15R	10" x 7"	PLASTIC
--------	----------	---------



NMC215R	10" x 7"	PLASTIC
---------	----------	---------



NMC26P	10" x 7"	ADHESIVE
NMC26R	10" x 7"	PLASTIC



NMC31R	10" x 7"	PLASTIC
--------	----------	---------



NMC49P	10" x 7"	ADHESIVE
--------	----------	----------



NMC57RB	10" x 14"	PLASTIC
---------	-----------	---------



NMC73P	10" x 7"	ADHESIVE
NMC73R	10" x 7"	PLASTIC



NMD108RB	10" x 14"	PLASTIC
----------	-----------	---------



NMD126R	10" x 7"	PLASTIC
---------	----------	---------



NMD139P	10" x 7"	ADHESIVE
NMD139R	10" x 7"	PLASTIC



NMD209RB	14" x 10"	PLASTIC
----------	-----------	---------



NMD211RB	14" x 10"	PLASTIC
----------	-----------	---------



NMD38P	10" x 7"	ADHESIVE
NMD38R	10" x 7"	PLASTIC



NMD39P	10" x 7"	ADHESIVE
--------	----------	----------



NMD46RB	14" x 10"	PLASTIC
---------	-----------	---------



AP07001	8" x 12"	PLASTIC
---------	----------	---------

SIGNS CONTINUED ON NEXT PAGE

**ROAD AND SHOP SAFETY PRODUCTS**



**NMD49RB** 14" x 10" PLASTIC



**NMD59R** 10" x 7" PLASTIC



**NMD79R** 10" x 7" PLASTIC



**NMFXPSER** 12" x 9" PLASTIC



**NMHC248** 3-1/4 x 5" ADHESIVE



**NMHC264** 3-1/4 x 5" ADHESIVE



**NMHC330** 3-1/4 x 5" ADHESIVE



**NMLOTAG1** 3-1/2 x 6" PLASTIC



**NMM23R** 18" x 4" PLASTIC



**NMM451R** 12" x 18" PLASTIC



**NMM24R** 10" x 8" PLASTIC



**NMM27R** 10" x 8" PLASTIC



**NMM51P** 4" x 12" ADHESIVE



**NMM52P** 4" x 12" ADHESIVE



**NMM58R** 10" x 7" PLASTIC



**NMMELR** 9" x 12" PLASTIC



**NMMERR** 9" x 12" PLASTIC



**NMN128R** 7" x 10" PLASTIC

THERE ARE HUNDREDS OF OTHERS SIGNS AVAILABLE. IF THERE IS SOMETHING YOU DON'T SEE, GIVE US A CALL AND WE'LL GET IT FOR YOU



**NMN18RB** 14" x 10" PLASTIC



**NMN34P** 10" x 7" ADHESIVE  
**NMN34R** 10" x 7" PLASTIC



**NMS1R** 7" x 7" PLASTIC



**NMM708R** 7" x 7" PLASTIC



**NMS21R** 7" x 7" PLASTIC



**NMSF45R** 10" x 7" PLASTIC



**NMSMV2** TRIANGLE PLASTIC



**NMTM10G** 18" x 12" PLASTIC



**NMTM2** 18" x 12" PLASTIC

**RED SAFETY FLARES**



15 MINUTE BURN TIME. RELIABLE AND ECONOMICAL WAY TO PROTECT GENERAL PUBLIC, POLICE OFFICERS, FIRE AND ROAD PERSONNEL, AS WELL AS THEIR EQUIPMENT. IDEAL FOR DIVERTING TRAFFIC AT THE SCENE OF AN EMERGENCY.

STOCK NO. AP0715

**ROAD SAFETY PRODUCTS**

**TRAFFIC CONES**



STOCK NO.	DESCRIPTION
SAM002	18" RED/ORANGE-BLK BASE
SAM003	28" RED/ORANGE-BLK BASE

**TRAFFIC CONE HOLDER**



MOUNTS TO VEHICLE BUMPER. FOR 18" AND 28" CONES ONLY

STOCK NO.	SAM007
-----------	--------

**REFLECTIVE TRAFFIC CONE COLLAR**



STOCK NO.	DESCRIPTION
SAM008	UPPER COLLAR 6"
SAM009	LOWER COLLAR 4"

**TRAFFIC PADDLES**



STOCK NO.	DESCRIPTION
SAM044	18" STOP AND SLOW
SAM047	26" STOP AND SLOW W/ 2" x 81" PLASTIC STAFF

**WARNING TRIANGLE KIT**



STOCK NO. AP84300

**PLASTIC BARRICADE**



MEETS MUTCD SPECIFICATIONS. BARRICADE IS 100% RECYCLABLE. REFLECTIVE PANELS ARE REPLACEABLE. JUST POP OFF OLD PANEL AND REPLACE WITH NEW VIA PLASTIC RIVETS. PROLONGS THE LIFE OF THE BARRICADE. RECESSED SLOTS FOR MOUNTING BARRICADE LIGHT, ENSURES LIGHT REMAINS ATTACHED WHEN BARRICADE IS IMPACTED.

STOCK NO. SAM016

**"A" FRAME BARRICADE**



STOCK NO.	DESCRIPTION
SAM017	INSTANT "A" FRAME

**CONSTRUCTION BARRELS**



MEETS OR EXCEEDS ALL MUTCD SPECIFICATIONS. CONSTRUCTED OF IMPACT-RESISTANT LINEAR HIGH DENSITY POLYETHYLENE. SINGLE FLAT SIDE ANTI-ROLL DESIGN. TESTED TO WITHSTAND IMPACTS WITHOUT UNUSABLE DAMAGE

STOCK NO. SAM018

**PLASTIC SAFETY FENCE**  
 MADE OF DURABLE POLYETHYLENE



STOCK NO.	DESCRIPTION
SAM034	ORANGE 4' x 50'

**REFLECTIVE ROLL-UP SIGNS**  
 ALL STANDARD MUTCD LEGENDS AND OVERLAYS AVAILABLE



STOCK NO.	DESCRIPTION
SAM053	ROAD WORK AHEAD 36" x 36"
SAM054	MEN WORKING 36" x 36"
SAM055	ROAD CLOSED 36" x 36"

**FIBERGLASS RIBS FOR ROLL-UP SIGNS**  
 48" RIBS

STOCK NO. SAM075

**MANY OTHER SIGNS  
 AVAILABLE UPON REQUEST**

### ROAD SAFETY PRODUCTS

#### OVERSIZE LOAD SIGNS



BRIGHT YELLOW WITH BLACK LETTERS. 18" x 8' WITH 5' ROPE TIES.

STOCK NO.	DESCRIPTION
SAM041	WIDE/OVERSIZE LOAD
SAM042	OVERSIZE LOAD
SAM043	WIDE LOAD

#### SURVEY MARKER FLAGS



2-1/2" x 3-1/2" WITH WIRE STEM

STOCK NO.	DESCRIPTION
SAM071	RED
SAM072	YELLOW
SAM073	ORANGE
SAM074	BLUE

#### 12" RED PLASTIC DISPOSABLE FLAGS



STOCK NO.	DESCRIPTION
SAM023	

#### WARNING FLAG



STOCK NO.	DESCRIPTION
SAM025	18" x 18" VINYL

#### 18" HEAVY DUTY MESH SAFETY FLAG



STOCK NO.	DESCRIPTION
SAM0252	18" x 18" MESH

#### ROTATING STROBE WITH MAGNETIC BASE 12 VOLT



STOCK NO. SAM031

12 V REPLACEMENT BULB FOR ROTATING STROBE LIGHT

STOCK NO. SAM032

#### FLASHING BARRICADE LIGHT



4D LED SOLAR CELL. BLINKING, STEADY BURN AND THREE WAY (BLINK, STEADY BURN, OFF) OPERATIONAL MODES AVAILABLE.

STOCK NO. SAM0291 (ORANGE REFLECTOR)

WRENCH FOR 4D LED FLASHER  
STOCK NO. SAM0292

#### RUBBER WHEEL CHOCK



MEETS OSHA REQUIREMENTS  
STOCK NO. SAM070

#### REFLECTIVE VEST



STOCK NO.	DESCRIPTION
SAM020	NYLON MESH
SAM022	LIME MESH W/SILVER REFLECTOR
SAM0224	LIME MESH W/ORANGE REFLEC.
SAM02241	LIME MESH W/SILVER REFLEC. 2XL-5XL

#### CLASS 3 VEST



HOOK AND LOOP CLOSURE, SHORT-SLEEVE, LIGHTWEIGHT. 2" REFLECTIVE TAPE. TWO 360° HORIZONTAL STRIPES, TWO VERTICAL STRIPES, AND TWO SLEEVE STRIPES.

STOCK NO.	DESCRIPTION
SAM0225	LARGE
SAM0226	X LARGE
SAM0227	XX LARGE
SAM0228	XXX LARGE
SAM02288	XXXX LARGE

A PAT ON THE BACK , THOUGH ONLY A FEW VERTEBRAE REMOVED FROM A KICK IN THE PANTS, IS MILES AHEAD IN RESULTS.  
--BENNET CERF



**FIRE EXTINGUISHERS**



TRUSTED FIRE PROTECTION FROM *KIDDE*, THE WORLD LEADER IN CONSUMER FIRE SAFETY PRODUCTS. DOT APPROVED. EASY-TO-READ PRESSURE GAUGES ALLOW INSTANT, ACCURATE PRESSURE CHECK. SQUEEZE GRIP PROVIDES POSITIVE OPERATION. HANDLE AND LEVER MADE OF HEAVY GAUGE STEEL FOR ADDED STRENGTH. LEVER LOCKS TO VALVE TO PREVENT ACCIDENTAL DISCHARGE. CHIP-RESISTANT EPOXY FINISH ON ALL CYLINDERS. ALL UNITS (EXCEPT MINI) INCLUDE WALL BRACKET FOR MOUNTING.



**CLASSES OF FIRE**

- A:** COMMON COMBUSTIBLES, WOOD, PAPER, CLOTH, RUBBER, TRASH, AND MOST PLASTICS.
- B:** FLAMMABLE LIQUIDS, GASOLINE, KEROSENE, OIL, GREASE, SOLVENTS AND GASES.
- C:** LIVE ELECTRICAL EQUIPMENT.

**FIRE EXTINGUISHERS**

STOCK NO.	CLASS (TYPE)	DESCRIPTION (WEIGHT)
KID466141	BC	2-1/2 LBS.
KID466142	ABC	2-1/2 LBS.
KID466143	ABC	5 LBS.
KID466031	ABC	10 LBS.
466206	ABC	20 LBS.

*CONSULT CATALOG INDEX FOR ADDITIONAL SAFETY PRODUCTS*

*CONSULT CATALOG INDEX FOR ADDITIONAL SAFETY PRODUCTS*

**METAL FIRE EXTINGUISHER BRACKETS (FOR MOUNTING TO VEHICLES) DOT AND COAST GUARD APPROVED**

STOCK NO.	FITS MODEL #
KID896698	466141, 466142
KID896697	466143
KID270191	466031



*ADDITIONAL ITEMS AVAILABLE UPON REQUEST*



### ROPE CORD & TWINE

#### PURE MANILA ROPE



PURE NO. 1 GRADE MANILA ROPE OFFERS THE EASE OF HANDLING WITH GOOD WEAR RESISTANCE. HOLDS A KNOT WELL. MANILA ROPE FIBERS WILL ABSORB WATER. CONSULT RECOMMENDED WORKING LOAD SPECIFICATIONS FOR PROPER SIZE FOR SPECIFIC USE. COLOR: NATURAL. SOLD PER FT. BROKEN OR FULL SPOOL

STOCK NO.	ROPE DIA.	LENGTH (FT.)	WORK LOAD (LBS.)
WIN03	1/4	1250	77
WIN04	3/8	600	174
WIN05	1/2	600	341
WIN06	5/8	600	566
WIN07	3/4	600	695
WIN09	1"	600	1157

#### COTTON SASH CORD



FOR WINDOW SASH, CAMPING, AWNING CORD, OVERHEAD DOORS, FARM & GARDENING USES, TARPULINS & TIEDOWNS. COLOR: NATURAL COTTON. SOLD: PER/HANK

STOCK NO.	ROPE DIA.	LENGTH (FT.)	WORK LOAD (LBS.)
WIN30	3/16 (SIZE #6)	100	42

#### POLISHED JUTE TWINE



GOOD QUALITY WRAPPING AND PACKAGE TWINE. SOFT & UNIFORM, IT KNOTS TIGHTLY & HAS A HIGH BREAKING POINT. COLOR: NATURAL TAN

STOCK NO.	DIA. & SIZE
WIN35	3/32 (#36)

CAN'T FIND IT?  
REFER TO OUR CATALOG INDEX

#### BRAIDED NYLON



AN EXTREMELY STRONG, SOFT, LIGHTWEIGHT CORD WITH EXCELLENT RESISTANCE TO ROT, ABRASION, MILDEW, PETROLEUM PRODUCTS AND MOST CHEMICALS, AND WITH SHOCK ABSORBING ELASTICITY THAT ALLOWS IT TO WITHSTAND GREAT STRAIN. SOLID BRAIDED CONSTRUCTION STAYS ROUND AND WORKS WELL IN PULLEYS. COLOR: NATURAL SILVERY WHITE. SOLD: PER FT. BROKEN OR FULL SPOOL

STOCK NO.	ROPE DIA.	LENGTH (FT.)	WORK LOAD (LBS.)
WIN18	1/8	600	72
WIN19	3/16	500	153
WIN20	1/4	500	234
-	5/16	500	351
WIN22	3/8	500	495
WIN23	1/2	500	756

#### COTTON CABLE CORD



MANUFACTURED FROM COTTON SYNTHETIC FIBERS. USES: SEINE TWINE, STAGING TWINE, TROT LINE, CHALK AND MASON LINE.

STOCK NO.	DIA. & SIZE	LENGTH OR WEIGHT
WIN64	3/32 (#36)	200 FT. - 1/2 LB.
WIN72	1/8 (#72)	220 FT. - 1 LB.

#### CHALK LINE NYLON SEINE TWINE TWISTED



TOP GRADE TWINE TWISTED FROM 100% FILAMENT NYLON. MUCH STRONGER AND LONGER LASTING THAN COTTON TWINE BECAUSE IT HAS EXCELLENT RESISTANCE TO ROT, ABRASION, MILDEW, MARINE GROWTH, PETROLEUM PRODUCTS AND MOST CHEMICALS. A FEW OF NYLON SEINE TWINES' MANY USES ARE, NET REPAIR, FISHING LINE, CHALK LINE AND DUCK DECOY ANCHOR LINE, PLUS, MANY USES IN HOME, GARDEN, SHOP AND FACTORY. COLOR: NATURAL SILVERY WHITE.

STOCK NO.	SIZE NO.	LENGTH (FT.)	WORK LOAD (LBS.)
WIN63	#24	317	59

#### 1 PLY SISAL TWINE COMMON BINDER TWINE



FARM, INDUSTRY, HOMEOWNER USE; PROVIDES MAXIMUM STRENGTH & SOFTNESS. IDEAL FOR MANY SHIPPING APPLICATIONS. COLOR: NATURAL BROWN. SOLD BY ROLL ONLY.

#### STOCK NO.

WIN39	5# RL.
WIN40	50# RL.

#### TWISTED POLYPROPYLENE

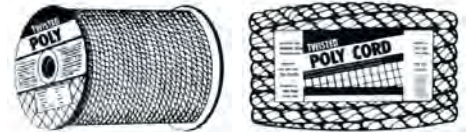

3-STRAND TWISTED, 100% MONO FILAMENT POLYPROPYLENE ROPE. THIS ROPE IS ALMOST TWICE AS STRONG AS MANILA AND WILL LAST MANY TIMES LONGER BECAUSE IT IS ROT RESISTANT WITH SUPERIOR RESISTANCE TO ABRASION. RESISTANT TO DAMAGE BY MILDEW, OIL, GREASE, GASOLINE, MARINE GROWTH AND MOST CHEMICALS. STANDARD COLOR: YELLOW IN ALL SIZES.

STOCK NO.	ROPE DIA.	LENGTH (FT.)	WORK LOAD (LBS.)
WIN50	1/4	50	113
WIN51	1/4	100	113
WIN52	1/4	600	113
WIN53	3/8	50	244
WIN54	3/8	100	244
WIN55	3/8	600	244
WIN56	1/2	50	420
WIN57	1/2	100	420
WIN58	1/2	600	420
WIN59	5/8	600	700

\* WORK LOADS ARE DERIVED BY TAKING 10-14% OF APPROX. AVG. OF NEW ROPE TENSILE STRENGTH.

1200' SPOOLS AVAILABLE UPON REQUEST



WE HAVE A LARGE STOCK OF MERCHANDISE WE CARRY TO SERVE YOU PROMPTLY

**ROPE BLOCKS AND EYE PULLEYS**

**STANDARD STEEL BLOCKS  
FOR MANILA ROPE**



SINGLE

STOCK NO.	BLOCK SIZE	DIA. ROPE	SHEAVE O.D.	WORK LOAD (LBS.)
CRM261B4	4"	1/2	2-1/4	900
CRM261B5	5"	5/8	3"	1200

ALL STEEL BLOCKS EQUIPPED WITH LOOSE LATCH EYE HOOK

DOUBLE AND TRIPLE BLOCKS AVAILABLE TO ROPE DIA. 1-1/4 UPON REQUEST

**SOLID EYE PULLEYS**



SINGLE WHEEL  
ELECTRO PLATED GRAY IRON

STOCK NO.	SIZE SHEAVE INCHES	DIA. ROPE INCHES
BM017412	1/2	5/32
BM017434	3/4	3/16
BM01741	1"	1/4
BM0174114	1-1/4	5/16
-	1-1/2	5/16
-	2"	7/16
-	2-1/2	1/2



DOUBLE WHEEL  
ELECTRO PLATED GRAY IRON

STOCK NO.	SIZE SHEAVE INCHES	DIA. ROPE INCHES
-	1/2	5/32
BM017634	3/4	3/16
BM01761	1"	1/4
-	1-1/2	5/16
-	2"	7/16

**SMALL WIRE ROPE BLOCK  
SWIVEL HOOK STYLE**



ALL ZINC PLATED W/BRONZE BUSHING  
SINGLE WHEEL

STOCK NO.	SHEAVE DIA.	MAX. W-R SIZE	WORKING LOAD LIMIT LBS.
WR02215	1-1/2	3/16	420
WR02220	2"	3/16	480
WR02225	2-1/2	1/4	550
WR02230	3"	1/4	640
WR02235	3-1/2	5/16	1240

REPLACEMENT SHEAVES AVAILABLE FOR ALL ABOVE SIZES

**SWIVEL EYE PULLEYS**



SINGLE WHEEL  
ELECTRO PLATED GRAY IRON

STOCK NO.	SIZE SHEAVE INCHES	DIA. ROPE INCHES
BM017312	1/2	5/32
BM017334	3/4	3/16
BM01731	1"	1/4
BM0173114	1-1/4	5/16
-	1-1/2	5/16
-	2"	7/16



DOUBLE WHEEL  
ELECTRO PLATED GRAY IRON

STOCK NO.	SIZE SHEAVE	DIA. ROPE
BM017834	3/4	3/16
BM01781	1"	1/4
-	1-1/2	5/16
-	2"	7/16

**SMALL WIRE ROPE BLOCK  
SWIVEL EYE STYLE**



ALL ZINC PLATED W/BRONZE BUSHING  
SINGLE WHEEL

STOCK NO.	SHEAVE DIA.	MAX. W-R SIZE	WORKING LOAD LIMIT LBS.
WR02115	1-1/2	3/16	420
WR02120	2"	3/16	480
WR02125	2-1/2	1/4	550
WR02130	3"	1/4	640
WR02135	3-1/2	5/16	1240

THIS SPACE RESERVED FOR FUTURE INVENTORY

## SLINGS AND TIE DOWN ASSEMBLIES

### HOW TO MEASURE SLINGS (AVAILABLE TYPE)

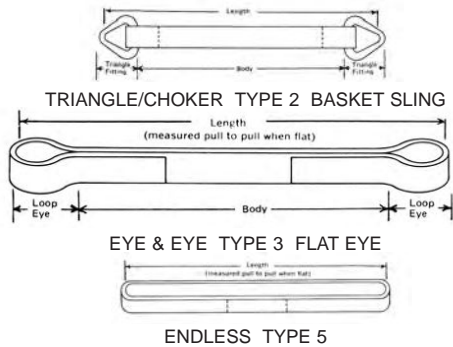

### ENDLESS WEB SLINGS

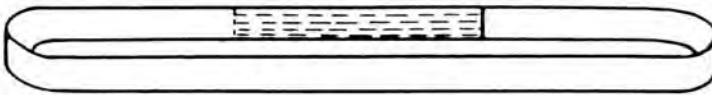

1 PLY HEAVY DUTY

STOCK NO.	SLING WIDTH		LENGTH (FT.)	RATED CAPACITIES IN LBS.		
				CHOKER	VERTICAL	BASKET
DD01	1"	x	3'	2600	3200	6400
DD02	1"	x	4'	2600	3200	6400
DD03	1"	x	6'	2600	3200	6400
DD04	1"	x	8'	2600	3200	6400
049	2"	x	3'	5100	6400	12800
DD05	2"	x	4'	5100	6400	12800
DD06	2"	x	6'	5100	6400	12800
DD07	2"	x	8'	5100	6400	12800
DD074	2"	x	10'	5100	6400	12800
DD075	2"	x	12'	5100	6400	12800

### EYE AND EYE WEB SLINGS

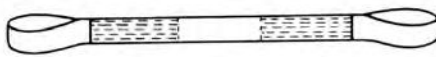

2 PLY NYLON HEAVY DUTY

STOCK NO.	SLING WIDTH		LENGTH (FT.)	RATED CAPACITIES IN LBS.		
				CHOKER	VERTICAL	BASKET
DD079	1"	x	3'	2600	3200	6400
DD08	1"	x	4'	2600	3200	6400
DD09	1"	x	6'	2600	3200	6400
DD10	1"	x	8'	2600	3200	6400
102	1"	x	12'	2600	3200	6400
DD12	2"	x	4'	5100	6400	12800
DD13	2"	x	6'	5100	6400	12800
DD14	2"	x	8'	5100	6400	12800
DD15	2"	x	10'	5100	6400	12800
DD16	2"	x	12'	5100	6400	12800
DD17	2"	x	14'	5100	6400	12800
DD18	2"	x	16'	5100	6400	12800
19	2"	x	18'	5100	6400	12800
DD20	2"	x	20'	5100	6400	12800
DD21	2"	x	24'	5100	6400	12800
22	3"	x	4'	7200	8900	17800
DD23	3"	x	6'	7200	8900	17800
DD24	3"	x	8'	7200	8900	17800
DD25	3"	x	10'	7200	8900	17800
DD26	3"	x	12'	7200	8900	17800
DD27	3"	x	14'	7200	8900	17800
DD271	3"	x	16'	7200	8900	17800
DD30	3"	x	20'	7200	8900	17800
DD34	4"	x	6'	9200	11500	23000
DD35	4"	x	8'	9200	11500	23000
DD36	4"	x	10'	9200	11500	23000
DD37	4"	x	12'	9200	11500	23000
DD38	4"	x	14'	9200	11500	23000
DD391	4"	x	16'	9200	11500	23000
DD396	4"	x	20'	9200	11500	23000

### RATCHETING SLINGS

HEAVY DUTY  
FOR MAXIMUM CARGO CONTROL



NYLON WEB - RATCHET ACTION -EASY RELEASE WITH FLAT HOOKS

STOCK NO.	SLING WIDTH	LENGTH	BREAK STR. (LBS.)	WLL (LBS.)
DD87	2"	24 FT.	5,000	1665
DD88	2"	27 FT.	10,000	3335

### FIXED END REPAIR SLINGS

TO BE USED WITH DD88

STOCK NO.	DESCRIPTION
DD89	SHORT END
DD90	LONG END
DD91	FIXED END WITH RATCHET



NYLON WEB - RATCHET ACTION -EASY RELEASE WITH SNAP HOOKS

STOCK NO.	SLING WIDTH	LENGTH	BREAK STR. (LBS.)	WLL (LBS.)
DD85	1"	12 FT.	1,500	500

### FIXED END REPAIR SLINGS

TO BE USED WITH DD85

STOCK NO.	DESCRIPTION
DD925	LONG STRAP WITH HOOK
DD92	FIXED END WITH RATCHET



NYLON WEB - RATCHET ACTION -EASY RELEASE WITH WIRE HOOKS

STOCK NO.	SLING WIDTH	LENGTH	BREAK STR. (LBS.)	WLL (LBS.)
DD86	1"	12 FT.	3,000	1000

### ADJUSTABLE CARGO STRAP



1" WIDE NYLON WEB WITH LOCKING BUCKLE AND VINYL COATED END HOOKS. ADJUST FROM 1 FT. TO MAXIMUM LENGTH. IDEAL FOR SECURING CARGO TO CYCLES, VANS, PICKUPS, TRAILERS, BOATS, AND SNOWMOBILES.

STOCK NO.	LENGTH
DD82	6 FT.
DD83	9 FT.

### RUBBER TIE DOWN STRAPS BUNGEE CORD



STOCK NO.	LENGTH OF STRAP
APR715B	15"
APR722B	21"
APR731B	31"

REPLACEMENT S-HOOKS

STOCK NO.	APR7HOOK
-----------	----------

**WIRE ROPE - CABLE SLINGS**

**GALVANIZED AIRCRAFT CABLE**  
PREFORMED CLEAN AND  
DRY-DRAWN GALVANIZED

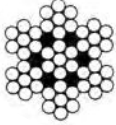

STOCK NO.	7 x 7 WORK LOAD LIMIT-LBS.	DIAM. INCHES
WR09	100	1/16
WR10	184	3/32
WR11	340	1/8
-	740	3/16



STOCK NO.	7 x 19 WORK LOAD LIMIT-LBS.	DIAM. INCHES
WR12	840	3/16
WR13	1400	1/4
WR14	1960	5/16
WR15	2880	3/8
WR16	4120	1/2
WR17	6440	5/8

STOCK NO.	7 x 19 WORK LOAD LIMIT-LBS.	DIAM. INCHES
WR151*	14000	3/8

\*SOLD IN 350 FT. SPOOLS ONLY

**STAINLESS STEEL AIRCRAFT CABLE**

TYPE 18.8 - FOR USE WHERE CORROSION  
RESISTANCE IS REQUIRED



STOCK NO.	DESCRIPTION	WORK LOAD LBS.	DIAM.
WR115	7 x 19	352	1/8
WR125	7 x 19	740	3/16
WR135	7 x 19	1400	1/4

**VINYL COATED (CLEAR P.V.C.)  
GALVANIZED AIRCRAFT CABLE**

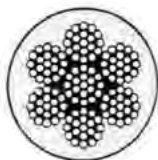

STOCK NO.	DESCRIPTION	COVERED TO INCHES	DIAM.
WR18	7 x 7	1/16	3/32
WR20	7 x 7	3/16	1/8
WR21	7 x 19	1/4	3/16

**WIRE ROPE SLINGS**  
PLAIN EYE & EYE  
6 x 19



STOCK NO.	ROPE DIA.	LENGTH (FT.)
DD601	1/4	x 4'
DD603	1/4	x 6'
DD620	3/8	x 4'
DD622	3/8	x 6'
DD623	3/8	x 8'
DD627	3/8	x 16'
DD632	1/2	x 6'
DD633	1/2	x 8'
DD634	1/2	x 10'
DD635	1/2	x 12'
DD636	1/2	x 14'
DD637	1/2	x 16'
DD643	5/8	x 8'
DD644	5/8	x 10'
DD645	5/8	x 12'
DD646	5/8	x 14'
DD647	5/8	x 16'
DD649	5/8	x 20'

**ALUMINUM DUPLEX SLEEVES (OVAL)**



STOCK NO.	SIZE
WR39	1/16
WR40	3/32
WR41	1/8
WR42	3/16
WR43	1/4

**MULTI-GROOVE HAND SWAGER**



(5 SIZE CAPACITY - 1/16, 3/32, 1/8, 5/32, 3/16)  
EYE AND EYE SLEEVE SPlicing IS MADE SURE  
AND EASY WITH THIS MULTI GROOVE HAND  
SWAGER, CAPABLE OF SWAGING (CRIMPING)  
FROM 1/16 TO 3/16 SLEEVES.

STOCK NO. WR60

*If we don't have it,  
we can get it for you!*  
  
*Call for details*

**PALLET/ SKID PULLER**



STOCK NO. HOD990

**WIRE ROPE CUTTER**



FOR FREE OR GENERAL CUTTING OF SOFT OR  
HARD STEEL CABLE OR WIRE ROPE TO  
CAPACITIES: COPPER/ALUMINUM - 1"  
WIRE ROPE - 1/2"

STOCK NO.	SIZE
WV90950	28"

**POCKET WIRE ROPE  
AND CABLE CUTTERS**

DROP FORGED CONSTRUCTION FOR LONG



LASTING QUALITY. PRECISION GROUND SHEAR  
CUT BLADES WILL EASILY CUT THROUGH FINE  
STRANDED WIRE. NON-SLIP CUSHION GRIP  
HANDLES FOR COMFORT.

CAPACITIES: COPPER/ALUMINUM - 1/4"  
WIRE ROPE - 3/16"

STOCK NO.	SIZE
HKP0690TN	7-1/2" LONG

THIS SPACE RESERVED FOR FUTURE  
INVENTORY

## WIRE ROPE HARDWARE

### LIGHT DUTY TURNBUCKLES

- FABRICATED FROM SPECIAL ZINC ALLOY.
- GUARANTEED NOT TO RUST OR FREEZE TO FITTINGS
- STEEL ZINC PLATED HOOKS AND EYES.

#### EYE & EYE



(DIMENSIONS IN INCHES)

STOCK NO.	THREAD DIA.	TAKE-UP	LENGTH CLOSED	LENGTH OPEN
DA21012	3/16	1-5/8	3-3/4	5-1/2
DA21014	1/4	2-3/8	5-1/2	7-7/8
DA21015	5/16	2-3/4	6-1/2	9-1/4
DA21016	3/8	3"	7-1/2	10-1/2

#### HOOK & EYE



(DIMENSIONS IN INCHES)

STOCK NO.	THREAD DIA.	TAKE-UP	LENGTH CLOSED	LENGTH OPEN
DA21024	1/4	2-3/8	5-1/2	7-7/8
DA21025	5/16	2-3/4	6-1/2	9-1/4
DA21026	3/8	3"	7-1/2	10-1/2

### FORGED TURNBUCKLES



FEDERAL SPECIFICATION FF-T-791b, TYPE 1  
FORM 1-CLASS 4

#### EYE & EYE

STOCK NO.	THREAD DIA.	TAKE-UP (INCHES)	AVG. O/A LENGTH W/ENDS CLOSED	HOT GALVANIZED
DA10712	3/8	6"	11-7/8	YES
DA10716	1/2	6"	13"	YES
DA10040	3/4	6"	20-3/4	SELF COLORED

### STUB END TURNBUCKLE

- DROP FORGED
- SELF COLORED



STOCK NO.	THREAD	TAKE-UP	O/A LENGTH CLOSED
DA10520	1/2	9"	17"

### HOOK AND EYE TURNBUCKLE

- FORGED
- GALVANIZED



STOCK NO.	THREAD	TAKE-UP	O/A LENGTH CLOSED
DA10112	3/8	6"	11-7/8
DA10116	1/2	6"	13"
DA10120	1/2	9"	17-1/2
DA10124	1/2	12"	20-1/2
DA10128	5/8	6"	16"
DA10132	5/8	9"	19-1/4
DA10136	5/8	12"	21-3/4
DA10140	3/4	6"	17-3/4
DA10144	3/4	9"	20-3/4
DA10148	3/4	12"	23-3/4

### JAW AND EYE TURNBUCKLE

- FORGED
- GALVANIZED



STOCK NO.	THREAD	TAKE-UP	O/A LENGTH CLOSED
DA11012	3/8	6"	12"
DA11016	1/2	6"	13"
DA11020	1/2	9"	16"
DA11024	1/2	12"	19"
DA11028	5/8	6"	16"
DA11032	5/8	9"	19"
DA11036	5/8	12"	22"
DA11040	3/4	6"	17"
DA11044	3/4	9"	20"
DA11048	3/4	12"	23"

### JAW AND JAW TURNBUCKLE

- FORGED
- GALVANIZED



STOCK NO.	THREAD	TAKE-UP	O/A LENGTH CLOSED
DA11112	3/8	6"	12"
DA11116	1/2	6"	13"
DA11120	1/2	9"	16"
DA11124	1/2	12"	19"
DA11128	5/8	6"	16"
DA11132	5/8	9"	16"
DA11136	5/8	12"	22"
DA11140	3/4	6"	17"
DA11144	3/4	9"	20"
DA11148	3/4	12"	23"

### TURNBUCKLE BODIES - ONLY

- DROP FORGED
- GALVANIZED



STOCK NO.	THREAD SIZE	BODY LENGTH
DA10612	3/8	x 6"
DA10616	1/2	x 6"
DA10640	3/4	x 6"

### WIRE ROPE CLIPS MALLEABLE-ZINC PLATED



STOCK NO.	ROPE SIZE
DA20900	1/16
DA20905	1/8
DA20910	3/16
DA20915	1/4

### STAINLESS STEEL CLIPS

STOCK NO.	SIZE
WR30	1/8
WR31	3/16
WR32	1/4

### FORGED WIRE ROPE CLIPS



- ALL CLIPS ARE SUPPLIED WITH COLD-FORGED DOUBLE CHAMFERED, HEAVY HEX, UNC 2B NUTS

- MEET FEDERAL SPECIFICATIONS FF C-450C TYPE 1, CLASS 1

- BASE, U-BOLT AND NUTS ARE HOT DIP GALVANIZED IN ACCORDANCE WITH ASTM SPECIFICATION A-153

STOCK NO.	ROPE SIZE
DA18500	1/8
DA18505	3/16
DA18510	1/4
DA18515	5/16
DA18520	3/8
DA18530	1/2
DA18540	5/8
DA18545	3/4
DA18550	7/8
DA18555	1"

### WIRE ROPE THIMBLES



HOT GALVANIZED  
USED FOR REINFORCING LOOPS ON WIRE ROPE

STOCK NO.	SIZE (ROPE) DIA.
DA40400	1/8
DA40405	3/16
DA40300	1/4
DA40305	5/16
DA40310	3/8
DA40320	1/2
DA40435	5/8
DA40440	3/4
DA40450	1"

**BOLT AND CHAIN CUTTERS, LEVER HOIST & CRANE**

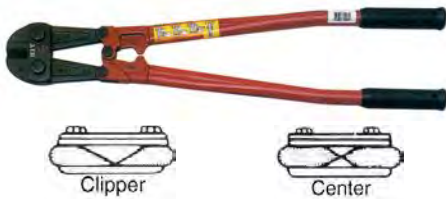

RECOMMENDED FOR GENERAL USE. SUITABLE FOR CONCRETE REINFORCING RODS, MEDIUM TENSILE AND SOFT BOLTS, RODS, RIVETS, BARS AND CHAIN. MAXIMUM PERMISSIBLE HARDNESS-ROCKWELL C40.

STOCK NO.	CUT	LENGTH
WV90300	CLIPPER	12"
WV90350	CLIPPER	18"
WV90450	CLIPPER	18"
WV90600	CENTER	24"
WV90750	CENTER	30"
WV90901	CENTER	36"

**REPLACEMENT JAWS FOR BOLT CUTTERS**

STOCK NO.	FITS CUTTER
WVRJ300	12"
WVRJ450	18"
WVRJ600	24"
WVRJ750	30"
WVRJ901	36"

**HYDRAULIC SHOP CRANE**



2 TON CRANE. 8 TON HYDRAULIC RAM FEATURES TOP-OF-STROKE AND SAFETY OVERLOAD BYPASS VALVES. BOOM AND LEGS ARE FULLY ADJUSTABLE. 12" x 3/8" LINK CHAIN INCLUDES HOOK WITH SAFETY LATCH. 3-1/2" STEEL CASTERS. MEETS ANSI/ASME PALD- 12 STANDARDS.

STOCK NO. JET106201

**RATCHET LEVER HOIST**



RUGGED, LIGHTWEIGHT AND PORTABLE. BUILT-IN LOAD BRAKE PROVIDES POSITIVE LOAD CONTROL. LOW HANDLE EFFORT LEVEL. HOOKS ROTATE 360°.

STOCK NO.	CAPACITY	LIFT FT.
JET187712	3000 LBS.	10'
JET187715	6000 LBS.	5'



**LEVER HOISTS**



**CABLE HOISTS**



REVERSIBLE TUBULAR HANDLE DESIGNED TO BEND FOR WARNING OF HAZARDOUS OVERLOAD. TWO-WAY, TWO-CAPACITY RIGGING. 360° HOOK ROTATION. CAST ALUMINUM ALLOY HOUSING. DOUBLE INTERLOCKING PAWL SYSTEM.

STOCK NO.	LIFT FT.	SINGLE LINE CAPACITY	DOUBLE LINE CAPACITY
EA115D	15	1000 LBS.	2000 LBS.
EA202WN	20	1500 LBS.	3000 LBS.
EA404WN	20	2000 LBS.	4000 LBS.

**CABLE ASSEMBLIES FOR ABOVE HOISTS**

STOCK NO. EA171 (115D HOIST)  
STOCK NO. EA271 (202WN HOIST)  
STOCK NO. EA471 (404WN HOIST)

**HAND CHAIN HOIST**



COMPACT AND LIGHTWEIGHT SIZE ALLOWS EASY INSTALLATION AND PORTABILITY. RATCHET-TYPE MECHANICAL LOAD BRAKE ENGAGES INSTANTLY FOR POSITIVE LOAD CONTROL. ONE-PIECE HANDWHEEL FOR LONG CHAIN WEAR. HOOKS ROTATE 360°.

JET		
STOCK NO.	CAPACITY	LIFT FT.
JET101704	2000	10'
JET101708	3000	10'
JET101712	4000	10'

**RATCHET LEVER HOISTS**



LIGHTWEIGHT AND RIGID DESIGN. REINFORCED HANDLE WITH RUBBER GRIP. DOUBLE ACTION RATCHET WORKS EVEN WITHOUT A LOAD. PROOF TESTED AND CERTIFIED.

STOCK NO	CAPACITY	LIFT FT.
JET187707	1500	5'
JET187708	1500	10'
JET187711	3000	5'
JET187712	3000	10'
JET187715	6000	5'
JET187716	6000	10'

### CHAIN

#### SASH CHAIN



SASH CHAIN IS MADE FROM A FLAT WIRE. USED GENERALLY WITH SASH CHAIN FIXTURES OR "S" HOOKS, RINGS AND OTHER ATTACHMENTS. FURNISHED IN ZINC FINISH AND PACKAGED 100 FEET.

STOCK NO.	TRADE SIZE NO.	MATERIAL SIZE INCH.	WORKING LIMIT LBS. STEEL
HOD01	8	.035	75
-	25	.042	94
-	30	.028	81
HOD02	35	.035	106
-	40	.042	131
HOD022	45	.050	175
-	50	.060	225

#### BULLDOG CHAIN



A WELDLESS CHAIN WHICH HAS BOTH LOOPS OF THE LINKS IDENTICAL IN SHAPE AND SIZE, WRAPPED IN THE MIDDLE WITH A CENTER TIE. IT IS THE MOST POPULAR OF THE WELDLESS CHAINS BECAUSE IT IS LIGHT, FLEXIBLE AND HAS FAIRLY GOOD STRENGTH. FURNISHED IN ZINC FINISH AND PACKAGED IN 100 FT. CARTONS.

STOCK NO.	TRADE SIZE NO.	MATERIAL DIA. INCH.	WORKING LOAD LIMIT LBS.
-	5	.062	55
-	4	.072	70
HOD07	3	.080	90
HOD08	2	.091	115
-	1	.105	155
-	1/0	.120	200
HOD09	2/0	.135	255
-	3/0	.148	305
-	4/0	.162	365

#### "S" HOOKS

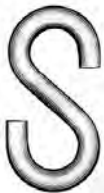

BRIGHT ZINC PLATED

NO.	STOCK SIZE WIRE DIA.	OVERALL LENGTH
DA41705	5/32	1-1/2
DA41710	3/16	1-3/4
DA41715	1/4	2-1/4
DA41720	5/16	2-1/2
DA41725	3/8	3-1/8

ADDITIONAL ITEMS AVAILABLE UPON REQUEST

#### SINGLE JACK CHAIN



JACK CHAIN IS A WELDLESS CHAIN, WITH LINKS TWISTED APPROXIMATELY 90 DEGREES TO EACH OTHER, FORMING A FIGURE "8" PATTERN. THE EYES ARE AT RIGHT ANGLES TO EACH OTHER. FURNISHED IN ZINC FINISH AND PACKAGED IN CARTONS OF 100 FT.

(BRASS) STOCK NO.	(STAINLESS) STOCK NO.	(STEEL) STOCK NO.	TRADE SIZE NO.	MATERIAL DIA. INCH.	WORKING LOAD LIMIT IN LBS.	
					STEEL	BRASS
-	-	-	18	.047	5	4
HOD03	-	HOD04	16	.062	10	8
-	-	HOD045	14	.080	16	11
-	HOD05SS	HOD05	12	.105	29	20
-	-	HOD06	10	.135	43	34
-	-	-	8	.162	60	-
-	-	-	6	.192	38	-

#### MACHINE CHAIN



A SHORT LINK, WELDED CHAIN, SUPPLIED IN EITHER STRAIGHT OR TWISTED LINK, ESPECIALLY USEFUL FOR APPLICATIONS REQUIRING GOOD RELATIVE STRENGTH AND FLEXIBILITY. ZINC FINISH. PACKED 100 FEET IN A CARTON. STRAIGHT LINK STOCKED.

STOCK NO.	TRADE SIZE NO.	MATERIAL DIA. INCH.	WORK LOAD LIMIT IN LBS.
HOD094	4	.120	215
HOD095	2	.148	325
-	1/0	.177	465
HOD10	2/0	.192	545
-	4/0	.218	700

#### COIL CHAIN



A LONG LINK, WELDED CHAIN, SUPPLIED IN EITHER STRAIGHT OR TWISTED LINK, WHICH IS SUITABLE FOR MANY GENERAL UTILITY APPLICATIONS. ZINC FINISH AVAILABLE. PACKED 100 FEET IN A CARTON.

STOCK NO.	TRADE SIZE NO.	MATERIAL DIA. INCH.	WORK LOAD LIMIT IN LBS.
-	4	.120	205
HOD107	2	.148	310
HOD109	1/0	.177	440
HOD11	2/0	.192	520
-	4/0	.218	670

#### BALL CHAIN

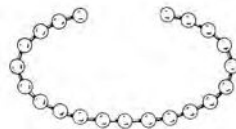

STANDARD BALL CHAIN WITH A NICKEL/STEEL PLATE FINISH. STRONG, LIGHTWEIGHT AND WILL NOT TANGLE OR KINK BECAUSE IT SWIVELS AND IS FLEXIBLE. UNLIMITED APPLICATIONS, SUCH AS SECURING TOOLS, DUST CAPS AND TANK CAPS. MINIMUM PURCHASE 1 FT.

STOCK NO.	SIZE
BCNS6	#6
BCNS8	#8
BCNS10	#10

#### BALL CHAIN COUPLINGS "B" STYLE

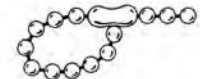

STOCK NO. BC6B (#6)  
STOCK NO. BC8B (#8)  
STOCK NO. BC10B (#10)

#### END STYLE



STOCK NO. BC6AD (#6)  
STOCK NO. BC10AD (#10)



**CHAIN, CHAIN CONNECTIONS AND FORGED CHAIN HOOKS**

**PROOF COIL CHAIN**



WELDED CHAIN, MADE FROM BASIC STEEL. IT IS A GENERAL PURPOSE CHAIN FOR AVERAGE PULLING OR RESTRAINING APPLICATIONS REQUIRING NEITHER A MAXIMUM TENSILE OR IMPACT STRENGTH. ZINC. PACKED BULK IN CONTAINERS. SOLD BY THE FOOT.

STOCK NO.	TRADE SIZE NO.	MATERIAL		NORM. INSIDE LINK		WORK LOAD LIMIT IN LBS.
		DIA. INCH.	DEC.	LENGTH	WIDTH	
HOD12	3/16	7/32	.218	.97	.40	800
HOD13	1/4	9/32	.281	1.0	.50	1250
HOD14	5/16	11/32	.343	1.1	.50	1900
HOD15	3/8	13/32	.394	1.25	.62	2650
HOD155	1/2	17/32	.531	1.50	.81	4500

**HI-TEST STEEL CHAIN**



WELDED CHAIN, MADE FROM A HIGHER CARBON CONTENT STEEL, WITH A GOOD STRENGTH TO WEIGHT RATIO. IT POSSESSES A TENSILE STRENGTH FAR GREATER THAN BASIC STEEL CHAIN AND IS HIGHLY RESISTANT TO ABRASIVE OR CUTTING ACTION AND NORMAL WEAR. PACKED BULK IN CONTAINERS. SOLD BY THE FOOT.

STOCK NO.	TRADE SIZE NO.	MATERIAL		NORM. INSIDE LINK		WORK LOAD LIMIT IN LBS.
		DIA. INCH.	DEC.	LENGTH	WIDTH	
HOD16	1/4	9/32	.281	.83	.39	2600
HOD17	5/16	11/32	.343	1.02	.48	3900
HOD18	3/8	13/32	.406	1.17	.56	5400
HOD19	1/2	17/32	.531	1.46	.75	9200

**FORGED DOUBLE CLEVIS LINKS**



ELECTRO-ZINC PLATED. DESIGNED FOR LINKING ALL POPULAR SIZES OF CHAIN TO RINGS, END LINKS, EYE HOOKS, PAD EYES, TRACTOR EYEBOLTS, ETC. PINS CAN BE REMOVED WITH PLIERS OR SCREWDRIVER. ALL PINS ALLOY STEEL, QUENCHED AND TEMPERED.

STOCK NO.	CHAIN SIZE	ULTIMATE STRENGTH
DA20700	1/4 OR 5/16	13,000
DA20701	3/8	18,800
DA20705	1/2	28,000

**FORGED CONNECTING LINKS**



FORGED STEEL, QUENCHED AND TEMPERED. INTEGRAL RIVETS JOIN THE TWO HALVES MATCHED LUGS DISTRIBUTE THE LOAD. INTERLOCKING LUGS FROM 3/8" TO 1". SELF COLORED.

STOCK NO.	SIZE	INSIDE DIMENSION	RATED CAPACITY
DA18805	1/4	7/16 x 13/16	1400
DA18810	5/16	15/32 x 29/32	2100
DA18815	3/8	9/16 x 1-3/32	2800
DA18820	7/16	19/32 x 1-3/16	3500
DA18825	1/2	23/32 x 1-15/32	4150

**CHAIN REPAIR LINKS**

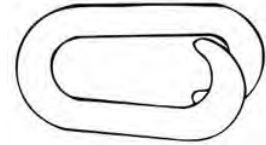

THE COMMON LAP LINK. ZINC PLATED. THE QUICKEST AND MOST ECONOMICAL WAY TO CONNECT TWO PIECES OF CHAIN - OR CHAIN TO EYELET, SNAP, RING, ETC.

STOCK NO.	WIRE DIA.	INSIDE WIDTH	INSIDE LENGTH
DA40700	3/16	1/2	1"
DA40705	1/4	1/2	1-1/4
DA40710	5/16	3/4	1-1/2
DA40715	3/8	3/4	2"
DA40720	1/2	1"	2-1/2

**QUICK LINKS**

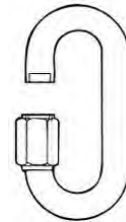

ZINC PLATED. FOR QUICK CONNECTION OF CHAIN, CABLE AND WIRE ROPE. NO TOOLS REQUIRED. EASILY TIGHTENED WITH FINGERS. CAN BE USED OVER AND OVER AGAIN.

STOCK NO.	SIZE WIRE DIA.	OVERALL LENGTH	JAW OPENING	LOAD LIMIT
BM735316	3/16	1-7/8	1/4	440
BM735014	1/4	2-1/4	9/32	660
BM7350516	5/16	2-15/16	3/8	1540
BM735038	3/8	3-1/8	7/16	1760
BM735012	1/2	4-1/8	19/32	2860

**CLEVIS GRAB HOOK**



HEAT TREATED/PAINTED RED. USE WITH HI-TEST CHAIN.

STOCK NO.	SIZE CHAIN	WORK LOAD LIMIT (LBS.)
DA20405	1/4	2600
DA20410	5/16	3900
DA20415	3/8	5400
DA20425	1/2	9200

## CHAIN CONNECTORS, FORGED CHAIN HOOKS AND LIFTING MAGNETS

### CLEVIS SLIP HOOK



HEAT TREATED/PAINTED RED. USE WITH HI-TEST CHAIN.

STOCK NO.	SIZE CHAIN	WORK LOAD LIMIT (LBS.)
DA20205	1/4	2600
DA20210	5/16	3900
DA20215	3/8	5400
DA20225	1/2	9200

### SAFETY HOOKS



PAINTED, ALLOY STEEL. LATCH, SPRING, MACHINE SCREW AND NUT ARE STAINLESS STEEL.

STOCK NO.	MAX. LOAD
CHD23	1-1/2 TON
CHD24	2-1/2 TON
CHD25	3 TON
CHD26	4.5 TON

### HINGED UNIVERSAL CLAMP



HINGED HOOK RING ENABLES THE CLAMP TO BE USED AT ANY ANGLE. FITTED WITH A CAM OPERATED CLOSING MECHANISM THAT CAN BE REPLACED WITH A CHAIN PULL OPEN-CLOSE MECHANISM. FITTED WITH HARDENED SERRATED TEETH JAWS AND PADS THAT ARE SUITABLE FOR GRIPPING STEEL.

STOCK NO.	JAW OPENING	MAX. LOAD
LC010	0-3/4	2200 LBS.
LC011	0-1-1/4	4400 LBS.

STOCK NO.	JAW OPENING	MAX. LOAD
LC001	0-5/8	1100 LBS.
LC002	0-3/4	3300 LBS.

### SAFETY SWIVEL HOOK



PAINTED, ALLOY STEEL. LATCH, SPRING, MACHINE SCREW AND NUT ARE STAINLESS STEEL.

STOCK NO.	MAX LOAD
CHDSH1	1 TON
CHDSH2	1-1/2 TON
WRSH1	3 TON
WRSH2	4.5 TON
WRSH4	7.5 TON
WRSH45	8 TON
WRSH55	11.5 TON
WRSH6	16 TON

### LATCH KITS



STOCK NO.	CAPACITY
CHD22LK	1 TON
CHD23LK	1-1/2 TON
CHD25LK	2-3 TON
CHD26LK	4-1/2 TON
CHD27LK	7 TON
CHD28LK	11 TON

### ADDITIONAL ITEMS AVAILABLE UPON REQUEST

#### UNIVERSAL PLATE CLAMP



BODY OF CLAMP IS WELDED CONSTRUCTION. CAN BE USED TO LIFT PLATE FROM HORIZONTAL TO VERTICAL POSITION AND VICE VERSA. STANDARD CLAMP IS FITTED WITH A HOOK RING THAT CAN BE REPLACED WITH A SHORT LENGTH OF CHAIN AND MASTER LINK. CLAMP JAWS AND PADS ARE MANUFACTURED FROM HIGH TENSILE STEEL.

STOCK NO.	JAW OPENING	MAX. LOAD
LC001	0-5/8	1100 LBS.
LC002	0-3/4	3300 LBS.

### ANCHOR SHACKLES SCREW PIN



HOT GALVANIZED. FORGED STEEL. SCREW PIN ANCHOR SHACKLES MEET FEDERAL SPECIFICATION RR-C-271B TYPE IV CLASS 1.

STOCK NO.	SIZE	CAP. IN TONS	INSIDE LENGTH	INSIDE WIDTH AT PIN	PIN DIA.
DA19105	1/4	1/2	1-1/8	1/2	5/16
DA19110	5/16	3/4	1-7/32	17/32	3/8
DA19115	3/8	1"	1-7/16	21/32	7/16
DA19120	7/16	1-1/2	1-11/16	23/32	1/2
DA19125	1/2	2"	1-7/8	13/16	5/8
DA19130	5/8	3-1/4	2-3/8	1-1/16	3/4
DA19135	3/4	4-3/4	2-13/16	1-1/4	7/8
DA19140	7/8	6-1/2	3-5/16	1-7/16	1"
DA19145	1"	8-1/2	3-3/4	1-11/16	1-1/8
DA19155	1-1/4	12	4-11/16	2-1/32	1-3/8
DA19165	1-1/2	17	5-3/4	2-3/8	1-5/8

### PERMANENT LIFTING MAGNETS



LIFTING MAGNETS WITH NO ELECTRICITY REQUIRED. NO RISK OF MAGNETIC FAILURE DUE TO POWER FAILURE. IDEAL FOR MOST ANY WORKPIECE. BI-POLAR DESIGN FOR LIFTING FLATS AND ROUNDS. TOTALLY PORTABLE. NO WIRES AND NO BATTERY TO CHARGE. EASY ON/OFF DESIGN FOR SINGLE OPERATOR. IMMEDIATELY RELEASES FROM WORKPIECE. FRICTIONLESS MOVEMENT: NO WEARING PARTS AND NO MAINTENANCE.

STOCK NO.	WEIGHT LBS.	SAFE WORKING LOAD LBS.		TESTED LOAD LBS.
		FLAT	ROUND	
LM003	53	1320	660	3960
	1000	75	2200	6600
	1500	145	3300	9600

BEWARE THE FLATTERER: HE FEEDS YOU WITH AN EMPTY SPOON.

--COSINO DEGREGRIO

**GRADE 100 AND GRADE 80 ALLOY CHAIN & ACCESSORIES**

GRADE 100 HAS BECOME THE INDUSTRY STANDARD FOR LIFTING CHAIN, ALL ITEMS SHOWN ARE GRADE 100 UNLESS MARKED AS GRADE 80. WE WILL BE REPLACING ALL REMAINING GRADE 80 ITEMS WITH GRADE 100 AS WE SELL OUT.

**CLEVIS GRAB HOOK**  
ALLOY TYPE



STOCK NO.	CHAIN SIZE	WORK LOAD LIMITS LBS.	LOAD PIN DIA.
HOD928	9/32	4,300	23/64
HOD9285	5/16	5,700	25/64
HOD929	3/8	8,800	31/64
HOD930	1/2	15,000	5/8
HOD931	5/8	22,600	51/64

**OBLONG MASTERLINK**



STOCK NO.	WIRE DIA.	INSIDE WIDTH	INSIDE LENGTH	CHAIN SIZE SING.	DBL.
HOD907	5/8	2-1/2	4-1/4	9/32	9/32
HOD908	7/8	3-1/2	6-1/4	3/8, 1/2	3/8
HOD909	1	4	7	1/2, 5/8	1/2
HOD910	1-1/4	4-3/8	8	5/8, 3/4	5/8

**ALLOY COUPLING LINK**



STOCK NO.	CHAIN SIZE	OUTSIDE WIDTH	INSIDE WIDTH	INSIDE HEIGHT
HOD921	9/32	1-3/4	11/16	2"
HOD922	3/8	2-1/2	29/32	2-3/4
HOD923	1/2	3-1/8	1-13/64	3-1/2
HOD924	5/8	4-1/8	1-15/32	4"

**CLEVIS SHORTENING HOOK**



FOR MOUNTING INTO ASSEMBLIES REQUIRING A SHORTENING CAPABILITY. CAN BE USED WITH ANY MASTER LINK ASSEMBLY. COMPACT AND CONVENIENT FITTING. NOT FOR USE IN BASKET CONFIGURATIONS.

STOCK NO.	CHAIN SIZE	WORK LOAD LIMIT LBS.
HOD946	9/32	4,300
HOD947	3/8	8,800
HOD948*	1/2	12,000

\*GRADE 80

**OBLONG RING WITH SHORTENING HOOKS**

STOCK NO.	SIZE	CHAIN SIZE	WORK LOAD LIMIT LBS.
HOD9461	5/8	9/32	3,500
HOD9471	7/8	3/8	3,800
HOD9481	1	1/2	12,000



**ALLOY CHAIN GRADE 100**

GRADE 100 ALLOY IS 25% STRONGER THAN GRADE 80 ALLOY, ALLOWS DOWNSIZING OF CHAIN AND COMPONENTS RESULTING IN LESS SLING WEIGHT AND INCREASED MOBILITY. THE NEW INDUSTRY STANDARD FOR OVERHEAD LIFTING.



**ALLOY CHAIN GRADE 80**

GRADE 80 ALLOY CHAIN IS RUGGED, VERSATILE & HIGH STRENGTH AND IS RECOMMENDED FOR USE IN OVERHEAD LIFTING APPLICATIONS. IT IS A LOW WEIGHT CHAIN WITH A HIGH CARBON CONTENT. HEAT-TREATED AND TEMPERED.

**CAUTION: WORK LOAD LIMITS NOT TO BE EXCEEDED.**

**WARNING: WHEN CHAIN ANGLE TO LOAD IS LESS THAN 30 DEGREES, EXCESSIVE STRESS TENSION CAN OCCUR CAUSING DAMAGE TO AND FAILURE OF CHAIN, AND INJURY OR DEATH TO THE USER.**

STOCK NO.	CHAIN SIZE IN.	WORKING LOAD LIMIT MM	MATERIAL DIA.
HOD900*	9/32	7	3,500
HOD901	3/8	10	8,800
HOD902	1/2	13	15,000
HOD903	5/8	16	22,600

\*GRADE 80

**CUSTOM-ASSEMBLED ALLOY CHAIN SLINGS**



WE STOCK THE ACCESSORIES FOR OUR CUSTOMERS TO CREATE ALLOY CHAIN SLINGS. HOWEVER, WE ALSO HAVE THE CAPACITY TO CREATE ANY CONFIGURATION OF ALLOY CHAIN SLINGS IN-HOUSE, BASED UPON CUSTOMER SPECIFICATIONS. GIVE US A CALL FOR MORE DETAILS.

**SLING IDENTIFICATION TAGS**

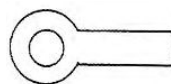

ZINC PLATED

STOCK NO. HOD999

**CLEVIS SLING HOOK**

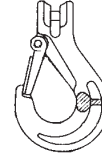

STOCK NO.	CHAIN SIZE	WORK LOAD LIMIT LBS.	LOAD PIN DIA.
HOD935	9/32	4,300	23/64
HOD936	3/8	8,800	29/64
HOD937	1/2	15,000	19/32
HOD938	5/8	22,600	1-7/8

**SAFETY LATCH KITS**

TO REPAIR PEWAG BRAND GRADE 80, 100, AND 120 SLING HOOKS.

STOCK NO.	SIZE
HOD960	9/32
HOD961	3/8
HOD962	1/2

**CLEVIS FOUNDRY HOOK "KF" STYLE**



STOCK NO.	CHAIN SIZE	WORK LOAD LIMIT LBS.
HOD949	9/32	4,300
HOD9491	3/8	8,800
HOD9492	1/2	15,000

**CLEVIS FOUNDRY HOOK "F" STYLE**



STOCK NO.	CHAIN SIZE	WORK LOAD LIMIT LBS.
HOD9493	5/8	22,600

**MASTERLINK SUB-ASSEMBLY**



STOCK NO.	WIRE DIA.	INSIDE WIDTH	INSIDE LENGTH	CHAIN SIZE
HOD914	7/8	4-1/4	6-1/4	9/32
HOD915	1	4-1/4	7-1/2	3/8
HOD916	1-1/4	5-1/8	9	1/2
HOD917	1-1/2	6	10-3/4	5/8

**ALLOY WELD ON BUCKET HOOK**

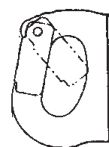

FOR WHEEL LOADER, EXCAVATOR AND LOADER BUCKETS.

STOCK NO.	WORK LOAD LIMIT TONS
HOD970	3
HOD972	5

### LOAD BINDERS

#### LOAD BINDERS STANDARD - TYPE



PROOF TESTED. LEVER NON-RATCHETING.

STOCK NO.	CHAIN SIZE	WORKING LOAD
CHBW1	3/16-1/4	2600
CHB13	5/16-3/8	5400
CHB31	5/16-3/8	6600

#### LOAD BINDERS RATCHET - TYPE



STOCK NO.	CHAIN SIZE	WORKING LOAD
CHBR7	5/16-3/8	5800
CHBR71	5/16-3/8	6600

#### TIE-DOWN CHAINS



GRADE 70 (TRANSPORT) YELLOW CHROMATE. USE FOR HIGHER WORK LOAD LIMITS. APPROVED FOR INTERSTATE TRANSPORT.

STOCK NO.	SIZE	WORKING LOAD LIMITS POUNDS
HOD950	5/16 x 20'	4700
HOD952	3/8 x 20'	6600

### ROLLER CHAIN AND ACCESSORIES

#### ROLLER CHAIN



SINGLE-STRAND ROLLER CHAIN IS PACKAGED IN 10 FT. ROLLS. ONE CONNECTING LINK INCLUDED.

STOCK NO.	ANSI NO.
C3510	35
C4010	40
C4110	41
C5010	50
C6010	60
C8010	80

ADDITIONAL STYLES AND SIZES OF ROLLER CHAIN AVAILABLE UPON REQUEST

CALL IN YOUR ORDER AND REFER TO OUR CATALOG STOCK NUMBERS FOR USER-FRIENDLY SERVICE



#### ROLLER CHAIN CONNECTING LINKS



STOCK NO.	ANSI NO.
C35CL	35
C40CL	40
C41CL	41
C50CL	50
C60CL	60
C80CL	80
C100CL	100

#### ROLLER CHAIN OFFSET LINKS

STOCK NO.	ANSI NO.
-----------	----------



STOCK NO.	ANSI NO.
C35OL	35
C40OL	40
C41OL	41
C50OL	50
C60OL	60
C80OL	80
C100OL	100

#### CHAIN BREAKERS

HIGH-QUALITY TOOLS HAVE FORGED JAWS AND TOOL-STEEL PUNCH POINTS. DISCONNECTS RIVETED ROLLER CHAIN IN MINUTES.

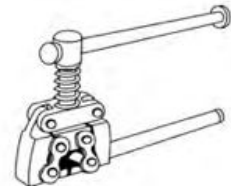

FOR ANSI NUMBERS 25 - 60

STOCK NO. C995

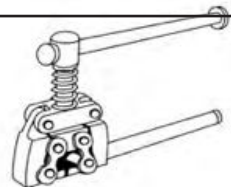

FOR ANSI NUMBERS 60 - 100

STOCK NO. C996

OTHER ROLLER CHAIN ACCESSORIES AVAILABLE UPON REQUEST

**STEEL AND POLY BANDING & ACCESSORIES**

**STEEL BANDING**



STOCK NO.	SIZE	TYPE	FT. PER LB. (APPROX.)
FLO50*	1/2" x .020 x 200'	STANDARD	30
FLO04	1/2" x .020	STANDARD	30
FLO08	5/8" x .023	STANDARD	21
FLO11	3/4" x .023	STANDARD	17
FLO14	3/4" x .031	HIGH TENSILE	13
FLO15	1-1/4 x .031	HIGH TENSILE	8

\* MINI COIL

*SOLD BY ROLL, VARY IN WEIGHT*

**STEEL BANDING TENSIONERS**



STOCK NO. FLO16 (3/8" - 3/4" REGULAR DUTY)  
STOCK NO. FLO17 (1-1/4" HIGH TENSILE)

**STEEL BANDING SEALS**



PUSH-TYPE	OPEN	SEMI-OPEN
STOCK NO.	SIZE	TYPE
FLO28	1/2	OPEN
FLO30	1/2	PUSH
FLO32	5/8	OPEN
FLO34	5/8	PUSH
FLO36	3/4	OPEN
FLO38	3/4	PUSH
FLO39*	3/4	SEMI-OPEN
FLO44	3/4	PUSH (LONG)
FLO45	1-1/4	SEMI-OPEN
FLO47	1-1/4	PUSH

\*HEAVY-DUTY

**STEEL BANDING SEALERS**



DOUBLE DOWN CUT (TWO NOTCH) CRIMPERS

STOCK NO.	SIZE	STOCK NO.	SIZE
FLO18	1/2	FLO19	5/8
FLO20	3/4	FLO22	1-1/4

**POLY BANDING KIT**



DESIGNED IN A COMPACT, ECONOMICAL LIGHTWEIGHT BOX. PORTABLE KIT INCLUDES 3,000 FEET OF QUALITY 1/2" PLASTIC BANDING, 300 1/2" WIRE BUCKLES, A STURDY HAND-HELD TENSIONING AND CUTTING TOOL, AND A COMPLETE SET OF INSTRUCTIONS.

STOCK NO. FLOHSK3000

WE'RE GLAD  
TO  
SHOW  
YOU  
ANY TOOL  
FOR  
EXAMINATION

**STEEL WIRE**

**ANNEALED WIRE BLACK STEEL**



IDEAL FOR MECHANICS, MANY INDUSTRIAL CONSTRUCTION AND FARMING APPLICATIONS. PACKAGE UNIT - ROLL OR COIL.

STOCK NO.	WIRE GAUGE (WIRE NO.)	UNIT PKG. (WIRE WT.)
TW01	#9	50 LB. ROLL

**REBAR TIE WIRE**

16 GA. BLACK. 3 1/2 LB ROLLS. FOR USE WITH REEL TYPE DISPENSERS OR AS GENERAL PURPOSE WIRE. PKG. UNIT - ROLL.

STOCK NO. TW22

**PERFORATED HANGER STRAP**



HANGER STRAP FOR 1/4" BOLTS. 3/4" x 24 GA. x 10 FT.

STOCK NO. PS34

ONE HYPOCHONDRIAC TO ANOTHER: "MY DOCTOR IS ON THE CUTTING EDGE OF TECHNOLOGY. HE TOLD ME TO TAKE TWO ASPIRINS AND FAX HIM IN THE MORNING."

**MECHANICS WIRE**



SOFT ANNEALED, BLACK WIRE. UNIT PKG.-SPOOL.

STOCK NO.	WIRE GAUGE	UNIT PKG. (WIRE WT.)
DOR110300	14	3-1/2 LB.
CHAMP9741	16	2 LB.
CHAMP9742	18	2 LB.

ASSISTANCE IS A PHONE CALL AWAY!



PRICES AND COMPLETE  
INFORMATION  
AVAILABLE UPON  
REQUEST.

### FORGED EYEBOLTS

#### FORGED EYE BOLTS



PLAIN PATTERN, 1030 STEEL AND HEAT TREATED.

STOCK NO.	THREAD SIZE	x	SHANK LENGTH
DA13611	1/4-20	x	1.00
DA13621	5/16-18	x	1.12
DA13631	3/8-16	x	1.25
DA13638	7/16-14	x	1.38
DA13641	1/2-13	x	1.50
DA12343*	1/2-13	x	6.00
DA13650	9/16-12	x	1.75
DA13661	5/8-11	x	1.75
DA13672	3/4-10	x	2.00
DA10049	3/4-10	x	8.00
DA13682	7/8-9	x	2.25
DA10057	7/8-9	x	9.00
DA13702	1"-8	x	2.50
DA13712	1-1/8-7	x	2.75
DA13723	1-1/4-7	x	3.00
DA13753	1-1/2-6	x	3.50

\*GALVANIZED

ADDITIONAL SIZES AVAILABLE UPON REQUEST

#### PAD "D" EYES



DROP FORGED. FOR WELDING APPLICATIONS.

STOCK NO.	DESCRIPTION
DA41506	1-3/8 I.D.
DA41507	1-1/2 I.D.

#### FORGED EYE NUTS

SELF-COLORED



STOCK NO.	SIZE
DA16037	3/8-16
DA16050	1/2-13
DA16062	5/8-11
DA16075	3/4-10

**YOUR COMPLETE SOURCE FOR INDUSTRIAL SUPPLIES**

#### SHOULDER EYE BOLTS



DROP FORGED, 1030 STEEL, HEAT TREATED

STOCK NO.	THREAD SIZE	x	OVERALL LENGTH	SHANK LENGTH
DA14611	1/4-20	x	2.22	1.0
DA14621	5/16-18	x	2.66	1.12
DA14631	3/8-16	x	3.09	1.25
KFK20236	3/8-16	x	8"	6"
DA14638	7/16-14	x	3.41	1.38
DA14641	1/2-13	x	3.81	1.50
KFK20256	1/2-13	x	8.31	6"
DA14661	5/8-11	x	4.56	1.75
KFK20276	5/8-11	x	8.81	6"
DA14672	3/4-10	x	5.06	2.00
KFK20286	3/4-10	x	9.25	6"
DA14682	7/8-9	x	5.75	2.25
DA14702	1"-8	x	6.50	2.50
KFK20306	1"-8	x	10.250	6.00
DA14712	1-1/8-7	x	7.31	2.75
DA14723	1-1/4-7	x	8.00	3.00
DA14753	1-1/2-6	x	9.22	3.50
DA14780	2"-4-1/2	x	11.53	4.00

#### METRIC SHOULDER EYE BOLTS

STOCK NO.	THREAD SIZE
M250	8mm
M251	10mm
M252	12mm
M253	16mm
M254	20mm
M255	24mm

OTHER METRIC SIZES AVAILABLE

*SERVICE YOU CAN  
DEPEND ON*

EYES, HOOKS AND SNAPS

SCREW EYES



LAG SCREW THREAD - BRIGHT ZINC PLATED

STOCK NO.	WIRE DEC. SIZE	OVERALL LENGTH	SHANK LENGTH	I.D. EYE
GW112	.105	1-1/8	1/2	1/4
IV064420605*	.105	1-1/8	1/2	1/4
GW12	.105	1-3/16	1/2	3/8
GW108	.1620	1-1/2	3/4	25/64
GW6SCE	.1850	1-7/8	1"	1/2
GW104	.2253	2-1/8	1-1/4	31/64
GW4SCE	.2253	2-1/8	1-1/8	39/64
GW1101	.250	3-3/4	2-3/4	9/16
IV064041629**	.250	3-3/4	2-3/4	9/16
GW1102	.250	5"	4"	9/16
GW2SCE	.2625	2-5/8	1-3/8	23/32
DA40191	.3125	3-1/2	2-1/4	5/8
DA40192	.375	4"	2-1/2	3/4

\*BRASS  
\*\*STAINLESS STEEL

LAG SCREW HOOKS



SQUARE BEND LAG SCREW HOOK

STOCK NO.	SIZE
GW114H	1"
GW112H	1-3/8
GW110H	1-7/8
GW108H	2-1/4
GW106H	2-5/8
GW104H	3"

CLOTHES LINE HOOKS



LAG THREAD ZINC PLATED

STOCK NO.	SIZE	OVERALL LENGTH
DA40186	5/16	4-1/2
DA40187	3/8	5"

CUP HOOKS

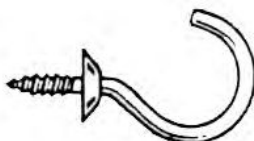

SOLID BRASS

STOCK NO.	NO. SIZE	OVERALL LENGTH	WIRE DIA.	BOX QTY.
GW8158	81-5/8	7/8	.072	100
GW8134	81-3/4	1-1/8	.091	100
GW8178	81-7/8	1-1/4	.091	100
GW811	81-1	1-1/2	.120	100

SPRING HOOKS  
PLATED FORMED STEEL



SPRING LOADED LOCKING PIN SNAPS. IDEAL FOR SMALL BOATS, WATER SKIING, MOORING, MOTOR SAFETY LINE, WINCH ROPE, ETC.

STOCK NO.	WIRE DIA.	OVERALL LENGTH	SNAP OPENING
BM245014	1/4	2-1/2	5/16
BM2450516	5/16	3-1/8	3/8
BM245038	3/8	4"	1/2
BM2450716	7/16	4-3/4	5/8
BM2450S38*	3/8	4"	1/2

\*STAINLESS STEEL

OPEN SWIVEL EYE CHAIN SNAPS



ZINC PLATED STEEL

STOCK NO.	OVERALL LENGTH	SNAP OPENING
BM1408	3-5/8	9/32

ROUND EYE BOLT SNAPS



NICKEL PLATED RUST-PROOF METAL

STOCK NO.	SIZE EYE	OVERALL LENGTH	SNAP OPENING
BM12558	5/8	3-1/2	3/8

OPEN EYE CHAIN SNAPS



CAST MALLEABLE IRON  
ELECTRO GALVANIZED

STOCK NO.	SIZE EYE	OVERALL LENGTH	SNAP OPENING
BM230	3/8	3-1/4	5/16

SWIVEL EYE SNAPS



NICKEL PLATED RUST-PROOF METAL

STOCK NO.	SIZE EYE	OVERALL LENGTH	SNAP OPENING
BM22258	5/8	3-1/2	9/32

SWIVEL EYE BOLT SNAPS



NICKEL PLATED RUST-PROOF METAL

STOCK NO.	SIZE EYE	OVERALL LENGTH	SNAP OPENING
BM22512	1/2	3-3/8	3/8
BM22558	5/8	3-1/2	3/8
BM225BT58	5/8	BRONZE 3-1/2	3/8

SWIVEL DECOY SNAPS



CAST RUST-PROOF METAL, NICKEL PLATED

STOCK NO.	SIZE EYE	OVERALL LENGTH	SNAP OPENING
BM33414	1/4	1-7/8	3/16

### EYES, HOOKS AND SNAPS

#### SWIVEL WIRE ROPE SNAPS



ZINC PLATED

STOCK NO.	SIZE EYE	OVERALL LENGTH	ROPE SIZE
BM40734	3/4	4-1/2	5/8
BM40678	7/8	4-5/8	3/4

#### SWIVEL DOG LEAD SNAPS



NICKEL PLATED RUST-PROOF METAL

STOCK NO.	SIZE EYE	OVERALL LENGTH	SNAP OPENING
BM43738	3/8	2-5/8	3/16

#### OPEN SWIVEL SNAPS



CAST RUST-PROOF METAL  
NICKEL PLATED

STOCK NO.	SIZE EYE	OVERALL LENGTH	SNAP OPENING
BM503738	3/8	2-5/8	3/16

#### SECURITY SNAPS-SWIVEL EYE



CAST MALLEABLE IRON

STOCK NO.	SIZE EYE	OVERALL LENGTH	SNAP OPENING
BM3142	3/4	4"	1/2

### BENT EYE BOLTS AND HOOK BOLTS

#### SWIVEL TRIGGER SNAP



STOCK NO.	DIA.	x	OVERALL LENGTH
BM501338	3/8	x	2-1/4

#### BENT EYE BOLTS



ZINC PLATED

STOCK NO.	DIA.	x	OVERALL LENGTH
DA21370	8-32	x	1-5/8
DA21371	8-32	x	1-3/4
DA21380	10-24	x	1-15/16
DA21381	10-24	x	1-11/16
DA21382	10-24	x	2-11/16
DA21400	1/4-20	x	2"
DA21410	1/4-20	x	2-1/2
DA21430	1/4-20	x	3"
DA21450	1/4-20	x	4"
DA21460	1/4-20	x	5"
DA21470	1/4-20	x	6"
DA21510	5/16-18	x	3-1/4
DA21520	5/16-18	x	4"
DA21530	5/16-18	x	5"
DA21540	5/16-18	x	6"
DA21610	3/8-16	x	4"
DA21620	3/8-16	x	5"
DA21630	3/8-16	x	6"
DA21640	3/8-16	x	8"
DA21670	3/8-16	x	13-1/2
DA21700	7/16-14	x	6"
DA21740	1/2-13	x	5"
DA21750	1/2-13	x	6"
DA21760	1/2-13	x	7"
DA21770	1/2-13	x	8"
DA21790	1/2-13	x	12"

#### BENT EYE BOLT WELDED CLOSED



ZINC PLATED

STOCK NO.	DIA.	x	OVERALL LENGTH
DA24740	3/8	x	4"
DA24760	3/8	x	6"

**FOR MORE EFFICIENT  
BUYING, HAVE STOCK  
NUMBERS READY WHEN  
PLACING PHONE ORDERS**

#### STAINLESS STEEL BENT EYEBOLTS



STOCK NO.	DIA.	x	OVERALL LENGTH
IV9000	3/16	x	2"
IV9003	1/4	x	2"
IV9004	1/4	x	3"
IV9005	1/4	x	4"
IV9009	5/16	x	3-1/4
IV9010	5/16	x	4"
IV9013	3/8	x	4"
IV9015	3/8	x	6"

#### HOOK BOLTS WITH NUTS



STOCK NO.	DIA.	x	OVERALL LENGTH
IV063740	1/4	x	2-5/8
IV063750	5/16	x	3-1/4
IV063760	3/8	x	4"

#### ROPE BINDER HOOKS



STOCK NO.	SIZE
IV067370	3-1/2
STA131050	4-3/4

ADDITIONAL ITEMS AND SIZES  
AVAILABLE UPON REQUEST





**U-BOLTS, PEGBOARD HOOKS AND MISCELLANEOUS HOOKS**

**U-BOLTS - ZINC PLATED W/NUTS  
(UNASSEMBLED)**



STOCK NO.	THREAD DIA. IN.	WIDTH BET. LEGS IN.	INSIDE LENGTH IN.	PIPE SIZE IN.
DA34010	1/4-20	3/4	1-1/4	3/8
DA34020	1/4-20	3/4	1-3/4	3/8
DA34030	1/4-20	3/4	2-1/4	3/8
DA34070	1/4-20	1"	1-3/4	1/2
DA34080	1/4-20	1-1/8	2"	3/4
DA34090	1/4-20	1-3/8	2-1/4	1"
DA34100	1/4-20	1-3/4	2-3/4	1-1/4
DA34110	1/4-20	2"	3-1/4	1-1/2
DA34120	1/4-20	1-1/2	3-1/2	1"
DA34200	5/16-18	1-3/8	2-3/16	1"
DA34210	5/16-18	1-3/8	3-11/16	1"
DA34220	5/16-18	1-3/4	2-11/16	1-1/4
DA34240	5/16-18	2"	2-11/16	1-1/2
DA34250	5/16-18	2"	3-11/16	1-1/2
DA34270	5/16-18	2-1/2	3-3/16	2"
DA34301	3/8-16	1-3/8	3-1/8	1"
DA34304	3/8-16	2"	3-1/8	1-1/2
DA34310	3/8-16	2-1/2	3-5/8	2"
DA34320	3/8-16	3"	4-1/8	2-1/2
DA34330	3/8-16	3-5/8	4-5/8	3"
DA34400	1/2-13	3"	4-1/2	2-1/2
DA34410	1/2-13	3-1/2	5"	3"
DA34420	1/2-13	4"	5-1/2	3-1/2
DA34430	1/2-13	4-5/8	6"	4"
DA34440	1/2-13	5-5/8	7"	5"
DA34450	1/2-13	6-3/4	8"	6"

**U-BOLTS  
STAINLESS STEEL**



STOCK NO.	THREAD DIA.	INSIDE WIDTH	INSIDE LENGTH	PIPE
GW304SS	1/4 x	1"	1-3/4	1/2
GW308SS	1/4 x	1-1/8 x	2"	3/4
GW310SS	1/4 x	2" x	3-1/2	1-1/2
GW320SS	5/16 x	1-3/8 x	2-1/2	1"
GW322SS	5/16 x	1-3/4 x	3"	1-1/4
GW327SS	5/16 x	2-1/2 x	3-1/2	2"

ADDITIONAL SIZES AVAILABLE

**U-BOLT STRAPS  
ZINC PLATED**



APPROXIMATE DIMENSIONS  
CENTER TO CENTER

STOCK NO.	WIDTH BET. SLOTS	LGTH. OVERALL	FITS U-BOLT	SLOT SIZE
DA35501	19/32	2-15/32	1/4	9/32 x 11/16
DA35502	1-3/16	3-1/16	1/4	9/32 x 11/16
DA35503	1-1/4	3-5/32	5/16	11/32 x 11/16
DA35504	1-13/16	3-11/16	5/16	11/32 x 11/16
DA35505	1-5/16	3-5/16	3/8	7/16 x 3/4
DA35506	2-3/8	4-3/8	3/8	7/16 x 3/4
DA35507	3-1/8	5-1/8	3/8	7/16 x 3/4

ADDITIONAL SIZES AVAILABLE

**S-HOOKS - ZINC PLATED**



STOCK NO.	SIZE WIRE DIA.	OVERALL LENGTH
GW54	.093	7/8
GW52	.105	1-1/4
DA41705	5/32	1-1/2
DA41710	3/16	1-3/4
DA41715	1/4	2-1/4
DA41720	5/16	2-1/2
DA41725	3/8	3-1/8

STAINLESS STEEL

IV9030	.141	1-1/2
IV9134	.177	2-1/8
IV9137	.273	2-3/4
IV9140	.306	3"

**LADDER STORAGE HOOK**

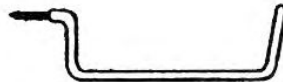

STOCK NO. IV368032 (VINYL COATED, 6" OAL)

**LARGE UTILITY HOOK**

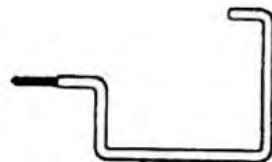

STOCK NO. IV368038 (VINYL COATED, 7-13/32" L)

**PEGBOARD HOOKS**

USE WITH 1/4" PERFORATED PEGBOARD



STOCK NO.	SIZE
GWTV14	4"
GWTV16	6"
GWTV18	8"

HEAVY-DUTY DOUBLE STYLE



STOCK NO. GWTW10 (2")

LOOP STYLE



STOCK NO. GWTX1L (9/16")  
STOCK NO. GWTX2L (1-1/2")

8" PEGBOARD TOOL HOLDER

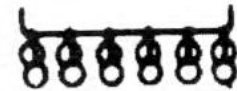

CAN BE USED WITH 1/8" OR 1/4" PEGBOARD

STOCK NO. GWTQ1

TOOL STORAGE HOOK

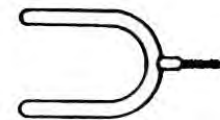

STOCK NO. GWSP31A (VINYL COATED, 4-1/8")

ADDITIONAL ITEMS AVAILABLE UPON REQUEST

YOU CAN'T BUILD A REPUTATION ON WHAT YOU ARE GOING TO DO.

--HENRY FORD

# STANLEY

## HARDWARE

# STANLEY

### BUTT HINGES

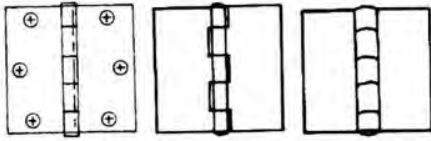

A). SQUARE	B). BROAD	C). BROAD
CORNER RESIDENTIAL	NO HOLE	NO HOLE EXTRA-HEAVY
STOCK NO.	SIZE	TYPE
STA081050	3" x 3"	A
STA082050	3-1/2 x 3-1/2	A
STA122370	4" x 4"	B
STA127400	2" x 2"	C
STA127850	3" x 3"	C
STA128350	4" x 4"	C
STA128550	5" x 5"	C

### SPECIALTY BUTT HINGES

STOCK NO.	SIZE	TYPE A
STA751820	2"	NON-REMOVABLE PIN
STA123300	2" x 2"	BRASS FAST PIN

### STRAP HINGES

SIZE: CENTER PIN TO LENGTH OF HINGE LEAF

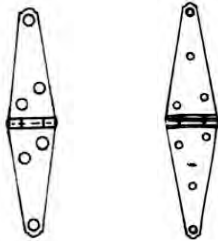

LIGHT HEAVY

STOCK NO.	SIZE	TYPE
STA140150	2"	LIGHT
STA140300	3"	LIGHT
STA141270	4"	HEAVY
STA141370	5"	HEAVY
STA141500	6"	HEAVY
STA141620	8"	HEAVY
STA141720	10"	HEAVY

### T-PLATES

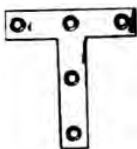

STOCK NO.	SIZE
STA301600	3" x 3"
STA301805	4" x 4"
STA301801	5" x 5"

### T-HINGES

SIZE: CENTER PIN TO LENGTH OF HINGE LEAF

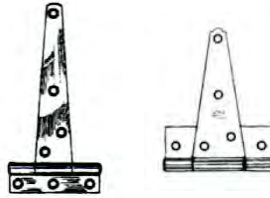

LIGHT HEAVY

STOCK NO.	SIZE	TYPE
STA142300	2"	LIGHT
STA142450	3"	LIGHT
STA145600	4"	HEAVY
STA144920	5"	HEAVY
STA145020	6"	HEAVY
STA145160	8"	HEAVY
STA145252	10"	HEAVY

### SAFETY HASPS



ROTATING POST NO SCREWS ADJUSTABLE STAPLE WITH SCREWS

STOCK NO.	SIZE	TYPE
STA511250	2-1/2	ROTATING
STA511500	3-1/2	ROTATING
STA511650	4-1/2	ROTATING
STA511800	6"	ROTATING
STA811800	3-1/2	ADJUSTABLE
STA811810	4-1/2	ADJUSTABLE
STA811830	6"	ADJUSTABLE

### SPECIALTY SAFETY HASPS



STAPLES NO SCREWS FIXED STAPLE HEAVY-DUTY HINGE WITH SCREWS

STOCK NO.	SIZE	TYPE
STA146501	#3	STAPLES
STA811980	7-1/2"	HD HINGE

### HEAVY-DUTY SAFETY HASPS MASTER-LOCK BRAND

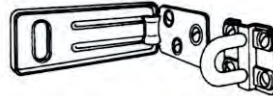

STRONG PROTECTION. COMPLETE WITH MOUNTING SCREWS.

STOCK NO.	SIZE
ML702	2-1/2
ML703	3-1/2
ML704	4-1/2
ML706	6"

### CORNER BRACES

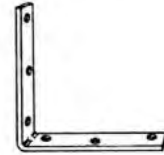

STOCK NO.	SIZE
STA303160	1-1/2
STA303320	2"
STA303480	2-1/2
STA303640	3"
STA303960	4"
STA304240	6"
STA304360	8"

### FLAT CORNER IRON

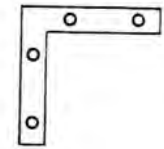

STOCK NO.	SIZE
STA305840	1/2 x 2-1/2
STA306040	1/2 x 3"
STA306440	5/8 x 3-1/2

### BARREL BOLT

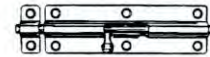

STOCK NO.	SIZE
STA757802	2-1/2
STA758062	4"
STA227110	4" (HEAVY)
STA227210	6" (HEAVY)
STA227270	8" (HEAVY)

### 6" HEAVY SQUARE SPRING BOLT (PADLOCKABLE)

STOCK NO.	STA231893
-----------	-----------

### CHEST HANDLES



STOCK NO.	SIZE
STA331301	#2-3/4
STA333380	#3-1/2
STA334180	#4

**STANLEY**

**HARDWARE**

**STANLEY**

**DOOR PULLS**



STOCK NO.	SIZE	FINISH
STA810500	5" x 1-1/4"	ZINC
STA810530	5-3/4" x 1-1/2"	ZINC
STA810560	6-1/2" x 1-3/4"	ZINC
STA810565	6-1/2" x 1-3/4"	BLACK
STA810590	7-7/8" x 2-1/4"	ZINC

**MENDING PLATES**



STOCK NO.	SIZE
STA300120	2"
STA300400	3"
STA300680	4"
STA300840	5"
STA301120	8"
STA301140	10"

*ADDITIONAL STANLEY ITEMS AVAILABLE  
UPON REQUEST*

**SLOTTED FLEXANGLE**



1-1/2" x 1-1/2" x 10' SECTIONS - 14 GAUGE (.080)

STOCK NO. FLX1

**PUNCHED STRAP**  
(PERFORATED FLAT STOCK)  
1-1/2" x 48" SECTIONS

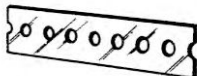

STOCK NO. FLX4

**CONTINUOUS HINGE**



**MEDIUM GAUGE**

STOCK NO.	SIZE
STA470740	1-1/16" x 6'
STA478340	1-1/2" x 6'
STA478500	2" x 6'

**CONTINUOUS HINGE  
HEAVY GAUGE STEEL  
NO HOLES**

STOCK NO.	SIZE	GAUGE
MMS120032	2" x 6'	.120
MMS120048	3" x 6'	.120
MMS120064	4" x 6'	.120
MMS180080	5" x 6'	.180
MMS180096	6" x 6'	.180

**CONTINUOUS HINGE  
TYPE 304 STAINLESS STEEL  
NO HOLES**

STOCK NO.	SIZE	GAUGE
MMSS040017	1-1/16" x 6'	.040
MMSS062024	1-1/2" x 6'	.060
MMSS074032	2" x 6'	.075
MMSS120048	3" x 6'	.120
MMSS120064	4" x 6'	.120

**\* QUALITY PRODUCTS \***  
**\* EXCELLENT SERVICE \***

**COAT & HAT HOOK**



STOCK NO. STA756103 (2 PK)

*ADDITIONAL STANLEY ITEMS AVAILABLE  
UPON REQUEST*

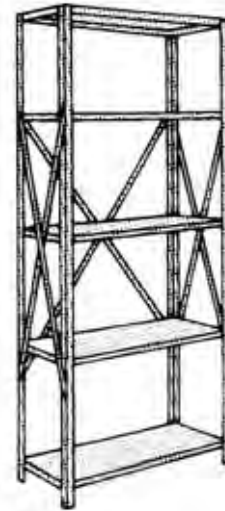

**USED HEAVY-DUTY SHELIVING**

WHEN AVAILABLE, **WE** OFFER A GOOD VARIETY OF QUALITY USED HEAVY-DUTY SHELIVING UNITS. SIZES RANGE FROM (BUT ARE NOT LIMITED TO) 12", 18", 24" AND 36" DEEP. CALL FOR AVAILABILITY AND PRICES.

**BE SURE TO TELL YOUR FRIENDS ABOUT US!**

### BOLTABLE STEEL CONNECTOR HARDWARE

#### NON-STRUCTURAL 90° FRAMING ANGLES



STOCK NO.	SIZE	HOLE DIA.
CF20510	1/8 x 1-1/2	3/8
CF20614	1/8 x 3"	3/8
CF20616	1/8 x 5"	3/8
CF20618	1/8 x 7"	3/8
CF20620	1/8 x 9"	3/8

#### FLAT MENDING PLATES



STOCK NO.	SIZE	HOLE DIA.
CF22275	1/8 x 4-3/4	5/16
CF21820	1/8 x 6"	5/16
CF22385	1/8 x 9-1/2	5/16
CF21821	1/8 x 10"	5/16
CF21822	1/8 x 14"	5/16
CF41828	1/4 x 16"	5/16
CF41829	1/4 x 20"	5/16
CF22274	1-1/2 x 3"	5/16

#### STRUCTURAL GUSSET ANGLES

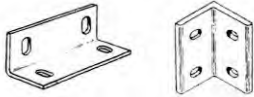

STOCK NO.	SIZE	HOLE DIA.
CF23631	1/8 x 5"	1/2
CF23632	1/8 x 7"	1/2
CF23633	1/8 x 9"	1/2
CF43700	1/4 x 4.60	1/2
CF43701	1/4 x 6.60	1/2

#### CLOSED 2 x 4 SUPPORT



STOCK NO.	SIZE	HOLE DIA.
CF36016	3/16 x 6.5	3/8

ADDITIONAL ITEMS AVAILABLE UPON REQUEST

#### 90° MENDING STRAPS

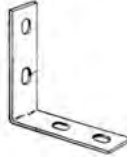

STOCK NO.	SIZE	HOLE DIA.
CF21920	1/8 x 3"	5/16
CF21921	1/8 x 5"	5/16
CF21922	1/8 x 7"	5/16
CF41927	1/4 x 6"	5/16
CF41928	1/4 x 8"	5/16
CF41929	1/4 x 10"	5/16
CF41930	1/4 x 12"	5/16

#### FLAT STRAP BRACES



STOCK NO.	SIZE	HOLE DIA.
CF22021	1/8 x 17"	5/16
CF22022	1/8 x 14"	5/16
CF22023	1/8 x 10"	5/16

#### 45° BEND STRAP BRACES



STOCK NO.	SIZE	HOLE DIA.
CF22121	1/8 x 17"	5/16
CF22122	1/8 x 14"	5/16
CF22123	1/8 x 10"	5/16

#### STRUCTURAL OFFSET BRACES

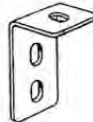

STOCK NO.	SIZE	HOLE DIA.
CF23363	1/8 x 6.7	1/2
CF33364	3/16 x 6.7	1/2

#### 90° POST SUPPORT



STOCK NO.	SIZE	HOLE DIA.
CF26425	1/8 x 2-1/4	1/2 & 5/16

DIMENSIONS IN INCHES UNLESS SPECIFIED OTHERWISE

#### STRUCTURAL 90° ELBOWS



STOCK NO.	SIZE	HOLE DIA.
CF23235	1/8 x 3"	1/2
CF23466	1/8 x 5"	1/2
CF33236	3/16 x 3"	1/2
CF43468	1/4 x 6"	1/2
CF23120*	1/8 x 3"	5/16
CF33121*	3/16 x 3"	5/16

\*NON-STRUCTURAL

#### 90° OFFSET LEGS

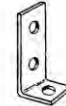

STOCK NO.	SIZE	HOLE DIA.
CF26418	1/8 x 2-1/2	1/2
CF26419	1/8 x 3-1/2	1/2
CF26420	1/8 x 7-1/2	1/2
CF36422	3/16 x 3-1/2	1/2
CF36423	3/16 x 7-1/2	1/2

#### ELBOW BRACES



STOCK NO.	SIZE	HOLE DIA.
CF24301	1/8 x 4-1/2	5/16
CF24302	1/8 x 6"	5/16
CF24311*	1/8 x 6"	5/8 or 13/16

\*STRUCTURAL

#### OPEN 2 x 4 SUPPORT

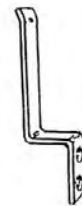

STOCK NO.	SIZE	HOLE DIA.
CF46116	1/4 x 5.8	3/8

ADDITIONAL ITEMS AVAILABLE UPON REQUEST

**Master Lock.**

**PADLOCKS & SECURITY PRODUCTS**

**Master Lock.**

**#1 PADLOCK**

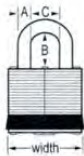

MAXIMUM SECURITY. LAMINATED STEEL BODY WITH A 1-3/4" LENGTH. SHACKLE DIMENSIONS:

- A) 5/16"
- B) 15/16"
- C) 3/4"

STOCK NO. ML1

**#1 PADLOCK KEYED ALIKE**



"SAME KEY" CONVENIENCE. ELIMINATES NEED FOR MULTIPLE KEYS WHERE NUMEROUS PADLOCKS ARE USED. ADDITIONAL KEYED ALIKE NUMBERS AVAILABLE UPON REQUEST.

STOCK NO.	KEYED TO
ML1KA2001	2001
ML1KA2050	2050
ML1KA2126	2126
ML1KA2396	2396
ML1KA2402	2402
ML1KA2495	2495
ML1KA2496	2496
ML1KA2497	2497
ML1KA2696	2696

**#1 PADLOCK MASTER KEY**



IDEAL FOR PERMITTING SUPERVISOR EMERGENCY ACCESS. MASTER KEY OPENS ALL LOCKS IN THE SYSTEM ALTHOUGH EACH LOCK HAS ITS OWN UNIQUE KEY. MASTER KEY IS PURCHASED SEPARATELY.

PADLOCK KEYED TO #AM22

STOCK NO. ML1MKAM22

MASTER KEY #AM22

STOCK NO. ML2KAM22

**Master Lock.**



SHACKLE DIMENSIONS

- A) DIAMETER
- B) LENGTH
- C) HORIZONTAL CLEARANCE

**#1 LONG SHACKLE KEYED ALIKE**

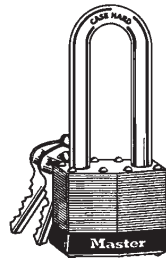

1-1/2" SHACKLE LENGTH.  
PADLOCK KEYED TO #2004.  
STOCK NO. ML1LFKA2004

1-1/2" SHACKLE LENGTH.  
PADLOCK KEYED TO #2020.  
STOCK NO. ML1LFKA2020

1-1/2" SHACKLE LENGTH.  
PADLOCK KEYED TO #2022.  
STOCK NO. ML1LFKA2022

1-1/2" SHACKLE LENGTH.  
PADLOCK KEYED TO #2497.  
STOCK NO. ML1LFKA2497

2-1/2" SHACKLE LENGTH.  
PADLOCK KEYED TO #0708.  
STOCK NO. ML1LJKA0708

**#3 PADLOCK**



MAXIMUM SECURITY. LAMINATED STEEL BODY WITH A 1-1/2" LENGTH. SHACKLE DIMENSIONS:

- A) 9/32"
- B) 3/4"
- C) 5/8"

STOCK NO. ML3

**#3 PADLOCK KEYED ALIKE**



STOCK NO.	KEYED TO
ML3KA0708	0708
ML3KA3220	3220
ML3KA3766	3766
ML3KA0353	0353
ML3KA3357	3357

**#3 PADLOCK MASTER KEY**



PADLOCK KEYED TO #SB727  
STOCK NO. ML3MKSB727

MASTER KEY #SB727  
STOCK NO. ML2KSB727

**#3 LONG SHACKLE**

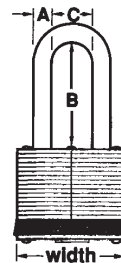

1-1/2" SHACKLE LENGTH.  
STOCK NO. ML3LF

2" SHACKLE LENGTH.  
STOCK NO. ML3LH

2" SHACKLE LENGTH.  
PADLOCK KEYED TO #0536  
STOCK NO. ML3LHKA0536

**#5 PADLOCK**

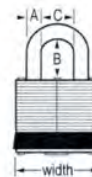

MAXIMUM SECURITY. LAMINATED STEEL BODY WITH A 2" WIDTH. SHACKLE DIMENSIONS:

- A) 3/8"
- B) 1"
- C) 15/16"

STOCK NO. ML5

**#5 PADLOCK KEYED ALIKE**



STOCK NO.	KEYED TO
ML5KAA473	A473
ML5KAA573	A573
ML5KAA519	A519
ML5KA2001	2001

LET US HELP YOU WITH SPECIAL APPLICATION PRODUCTS. IF IT'S NOT IN THE CATALOG, IT'S UP TO US TO GET IT FOR YOU

**Master Lock.**

**PADLOCKS & SECURITY PRODUCTS**

**Master Lock.**

**#7 PADLOCK**



GENERAL SECURITY. LAMINATED STEEL BODY WITH A 1-1/8" WIDTH. SHACKLE DIMENSIONS:  
A) 3/16"  
B) 9/16"  
C) 1/2"

STOCK NO. ML7

**#7 PADLOCK KEYED ALIKE**



STOCK NO. KEYED TO  
ML7KAP812 P812  
ML7KAP493 P493

**#15 PADLOCK**



MAXIMUM SECURITY. LAMINATED STEEL BODY WITH A 2-1/2" WIDTH. SHACKLE DIMENSIONS:  
A) 7/16"  
B) 1-1/4"  
C) 1-3/16"

STOCK NO. ML15

**#15 PADLOCK KEYED ALIKE**



STOCK NO. KEYED TO  
ML15KA19N464 19N464

**#17 PADLOCK**



MAXIMUM SECURITY. LAMINATED STEEL BODY WITH A 2" WIDTH. SHACKLE DIMENSIONS:  
A) 7/16"  
B) 1"  
C) 3/4"

STOCK NO. ML17



**Master Lock.**

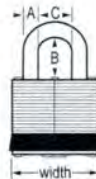

SHACKLE DIMENSIONS

- A) DIAMETER
- B) LENGTH
- C) HORIZONTAL CLEARANCE

**#17 PADLOCK KEYED ALIKE**



STOCK NO. KEYED TO  
ML17KA19T462 19T462

**#81 PADLOCK**

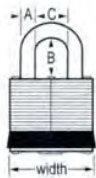

MAXIMUM SECURITY. LAMINATED STEEL BODY WITH A 1-3/4" WIDTH. SHACKLE DIMENSIONS:  
A) 5/16"  
B) 15/16"  
C) 3/4"

STOCK NO. ML81

**WARDED PADLOCKS**

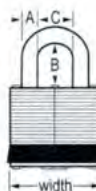

LAMINATED STEEL BODIES AND SINGLE LOCKING STEEL MECHANISMS, THESE LOCKS OFFER ATTACK RESISTANCE FOR MEDIUM TO LIGHT DUTY SECURITY APPLICATIONS. IDEAL FOR CONDITIONS WHERE SAND, DIRT OR ICE ARE A PROBLEM. PLATED TO RESIST RUST AND CORROSION.

1" WIDE BODY. SHACKLE DIMENSIONS:  
A) 5/32"  
B) 7/16"  
C) 3/8"  
STOCK NO. ML10

1-1/8" WIDE BODY. SHACKLE DIMENSIONS:  
A) 3/16"  
B) 1/2"  
C) 1/2"  
STOCK NO. ML105

(CONTINUED NEXT COLUMN)

**WARDED PADLOCKS**

1-1/2" WIDE BODY. SHACKLE DIMENSIONS:  
A) 1/4"  
B) 5/8"  
C) 9/16"  
STOCK NO. ML22

1-3/4" WIDE BODY. SHACKLE DIMENSIONS:  
A) 9/32"  
B) 13/16"  
C) 13/16"  
STOCK NO. ML500

**UNIVERSAL PIN SERIES PADLOCKS**

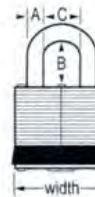

UNIVERSAL PIN PADLOCKS FOR KEYING CONVENIENCE. LOCKS PINNED TO CUSTOMERS KEYS IN MINUTES. OPERATES WITH SAME KEY AS MASTER LOCK PADLOCKS. 4-PIN TUMBLER CYLINDERS HELPS PREVENT PICKING.

1-3/4" WIDE BODY. SHACKLE DIMENSIONS:  
A) 5/16  
B) 15/16  
C) 3/4

STOCK NO. ML1UP

1-3/4" WIDE BODY. 2-1/2" SHACKLE. SHACKLE DIMENSIONS:  
A) 5/16  
B) 2-1/2  
C) 3/4

STOCK NO. ML1UPLJ

1-9/16" WIDE BODY. SHACKLE DIMENSIONS:  
A) 9/32  
B) 3/4  
C) 5/8

STOCK NO. ML3UP

1-9/16" WIDE BODY. 1-1/2" SHACKLE. SHACKLE DIMENSIONS:  
A) 9/32  
B) 1-1/2  
C) 5/8

STOCK NO. ML3UPLF

2" WIDE BODY. SHACKLE DIMENSIONS:  
A) 3/8  
B) 1"  
C) 15/16

STOCK NO. ML5UP

2" WIDE BODY. 1-1/2" SHACKLE. SHACKLE DIMENSIONS:  
A) 3/8  
B) 1-1/2  
C) 15/16

STOCK NO. ML5UPLF





**BATTERIES, FLASHLIGHTS AND LANTERNS**



**ALKALINE BATTERIES**



ALKALINE MAXIMUM INDUSTRIAL BATTERIES ARE GUARANTEED AGAINST LEAKAGE. UP TO 5 YEARS STORAGE LIFE. MULTI-PACKS ARE DATE CODED TO ASSURE FRESHNESS.

- D SIZE 6 PACK STOCK NO. RVALD
- AAA SIZE 8 PACK STOCK NO. RVALAAA
- C SIZE 6 PACK STOCK NO. RVALC
- 9-VOLT 6 PACK STOCK NO. RVAL9V
- AA SIZE 8 PACK STOCK NO. RVALAA

**HEAVY-DUTY CARBON ZINC BATTERY**

D SIZE 6 PACK STOCK NO. RVHDD



**6-VOLT LANTERN SPRING TERMINAL HEAVY-DUTY**



STOCK NO. RV6VHDM

**CALIPER/INSTRUMENT BATTERY**



USED IN CALCULATORS, WATCHES AND MEASURING INSTRUMENTS. LONG STORAGE LIFE. 1.5 VOLTS.

STOCK NO. RV357

**NIMH RENEWAL BATTERIES**



BETTER THAN REGULAR, SINGLE-USE ALKALINE BATTERIES BECAUSE THEY ARE REUSABLE 500 TO 1000 TIMES WHEN CHARGED IN A RENEWAL POWER STATION. LONGER LASTING CHARGE AND COME READY-TO-USE.

- D SIZE 2 PACK STOCK NO. RVNM7132
- AA SIZE 4 PACK STOCK NO. RVNM7154
- C SIZE 2 PACK STOCK NO. RVNM7142
- AAA SIZE 4 PACK STOCK NO. RVNM7244

**UNIVERSAL CHARGER**

CAN CHARGE RECHARGEABLE ALKALINE, NIMH AND NiCd BATTERIES AA/AAA/C/D AND 9-VOLT.



STOCK NO. RVPS3

**WORKHORSE LIGHTS**



THE RELIABLE WORKHORSE IS A PREMIUM FLASHLIGHT WITH A LONG RANGE BEAM AND CORROSION-RESISTANT CASE. CLASSIC STYLING AND SUPERIOR PERFORMANCE.

2 CELL AA SIZE (K4 BULB) STOCK NO. RVW2AAB

**ROUGHNECK LIGHTS**



SUPERIOR DEPENDABILITY AND TOUGHNESS. ADJUSTABLE SPOT-TO-FLOOD FOCUS. BRIGHT WHITE BULB. CHEMICAL AND SOLVENT RESISTANT CASE. WATERPROOF.

2 CELL D SIZE (K22 BULB) STOCK NO. RVR2D

3 CELL D SIZE (K32 BULB) STOCK NO. RVR3D

2 CELL AA SIZE (T12 BULB) STOCK NO. RVR2AAB

**UTILITY LIGHT**



2 CELL D SIZE UTILITY FLASHLIGHT. ECONOMICAL.

STOCK NO. RVIV2D

\*QUALITY PRODUCTS \*  
\*FAIR & COMPETITIVE PRICES \*  
\*EXCELLENT SERVICE \*



YOU CAN DEPEND ON US

WHAT COUNTS IS NOT NECESSARILY THE SIZE OF THE DOG IN THE FIGHT -- IT'S THE SIZE OF THE FIGHT IN THE DOG.  
--DWIGHT D. EISENHOWER

**FLOATING LANTERNS**



KRYPTON BLACK FLOATING LANTERN. USES 6VHDM BATTERY (NOT INCLUDED). K13 BULB. 4-1/2" REFLECTOR WITH SEALED LENS. RUGGED BODY. WEATHERPROOF SWITCH. LONG RANGE BEAM.

STOCK NO. RVKFL



FLOATING BLUE BEAM LANTERN. USES 6VHDM BATTERY (NOT INCLUDED). PR12 AND PR13 BULBS. LONG RANGE. RUGGED BODY.

STOCK NO. RVL295B

**ECONOMY FLASHLIGHT**



USES 2 "D" BATTERIES.

STOCK NO. MD306255

**INDUSTRIAL LIGHTS**



2 CELL D SIZE YELLOW INDUSTRIAL FLASHLIGHT WITH KRYPTON BULB.

STOCK NO. RVIN2K

**REPLACEMENT BULBS**



FOR ALL RAYOVAC AND FULTON FLASHLIGHTS AND LANTERNS.

STOCK NO.	DESCRIPTION
RVT12	HI-INTENSITY MINI-BULB AA/AAA
RV2222	2AA PENLIGHT BULB (2PK)
RVPR13	6V LANTERN BULB
K1	2C KRYPTON FOR ROUGHNECK R2C
RVK42	2AA / 2C KRYPTON W2AAB
RVK22	2D KRYPTON BULB (2 PK)
RVK32	3D KRYPTON BULB (2 PK)
RVK132	6V KRYPTON BULB (2 PK)





**FLASHLIGHTS AND REPLACEMENT BULBS**



**INDUSTRIAL HEAVY-DUTY FLASHLIGHT**



COMES WITH PARABOLIC SPOT REFLECTOR, WHICH GIVES OFF A PENETRATING, FOCUSED LIGHT BEAM. THE 901 IS CORROSION AND SHOCK-RESISTANT, AND HAS A HEAVY-DUTY SWITCH AND SWITCH GUARD. STANDARD YELLOW WITH BLACK ENDS. RIBBED FOR EASY GRIP. 2D CELLS (NOT INCLUDED). K22 BULB.

**STOCK NO. FUL901**

*SEE REPLACEMENT BULBS ON PREVIOUS PAGE*

**KRYPTON SERIES FLASHLIGHTS FROM**



918N



919N



938N



SUPER-BRIGHT KRYPTON BULBS FEATURED IN 900 SERIES LIGHTS. KRYPTON BULBS ARE ABOUT 70% BRIGHTER THAN ORDINARY BULBS. HEAVY-DUTY PLASTIC YELLOW BODY WITH BLUE END CAPS. 2D CELL (NOT INCLUDED). K22 BULB.

STOCK NO.	DESCRIPTION
FUL918N	2 CELL SUPER BRIGHT KRYPTON
FUL919N	SAME AS 918N WITH MAGNET
FUL938N	WITH MAGNA BEAM FLOOD REFLECTOR
FUL93KIB	2 CELL HEAVY-DUTY KRYPTON MAGNA BEAM (WATERPROOF)

**CONTINUITY TESTERS**



PERMITS LIGHT TO SERVE AS BOTH A CONTINUITY TESTER AND HANDY FLASHLIGHT AT THE SAME TIME. HEAVY-DUTY JACK PLUS INTO ENDCAP, CONVERTING LIGHT TO TESTER. INCLUDES 72" LEADS WITH ALLIGATOR CLAMPS. 2D CELLS (NOT INCLUDED). **"NOT FOR LIVE CIRCUITS"** CLEARLY STAMPED ON BODY.

STOCK NO.	DESCRIPTION
FUL905	PARABOLIC REFLECTOR LIGHT W/ CONTINUITY TESTER
FUL906	SAME AS 905 PLUS FIXED MAGNET

*SEE REPLACEMENT BULBS ON PREVIOUS PAGE*

**CALL IN  
YOUR  
ORDER  
AND  
REFER  
TO  
STOCK NUMBERS  
IN  
OUR  
CATALOG  
FOR  
USER-FRIENDLY  
SERVICE**

*CUSTOMER  
SATISFACTION  
IS THE KEY  
TO OUR  
SUCCESS*

**THIS IS A  
COMPREHENSIVE  
CATALOG  
OF OUR MAJOR LINES  
AND SERVICES,  
BUT IT DOES NOT SHOW  
ALL AVAILABLE  
PRODUCT LINES.  
IF THERE IS SOMETHING  
YOU NEED  
THAT IS NOT SHOWN,  
WE EITHER CARRY IT  
OR CAN GET IT.  
PLEASE CALL FOR  
INFORMATION.**

# STREAMLIGHT

## STYLUS FLASHLIGHT



FORMULATED FROM 6000 SERIES TEMPERED AIRCRAFT ALUMINUM WITH ANODIZED FINISH; NON-SLIP KNURLED GRIP. SOME SPECIAL FEATURES ARE THAT IT IS WATERPROOF, INDIVIDUALLY SERIALIZED, MOMENTARY "BLINK" SWITCH AND CONSTANT "ON" AND A POCKET CLIP. WITH AN AVERAGE 100,000 HOUR LIFETIME, A HIGH-INTENSITY LIGHT EMITTING DIODE REPLACES THE STANDARD BULB ALLOWING FOR SUCH A LONG LIFE EXPECTANCY. USES "AAAA" BATTERIES.

STOCK NO.	COVER COLOR	LENS COLOR
STR65012	SILVER	ARCTIC WHITE
STR65018	BLACK	ARCTIC WHITE

## STYLUS FLASHLIGHT



SAME GREAT FEATURES AS THE STYLUS LISTED ABOVE, EXCEPT IT HAS A BLUE LIGHT WHICH IS EXCELLENT FOR MAP READING.

STOCK NO.	COVER COLOR	LENS COLOR
STR65028	GOLD	BLUE

## GLARE GUARD



TO REDUCE GLARE WHEN IN CONFINED OR REFLECTIVE AREAS.

STOCK NO. STR65031

## STYLUS REACH



THE NEW STYLUS REACH HAS THE SAME GREAT FEATURES AS THE STYLUS BUT HAS A FLEXIBLE CABLE EXTENSION, ALLOWING YOU TO GET DEEP INTO THE TIGHTEST SPOTS. WITH A WATERPROOF, AIRCRAFT ALUMINUM CASING AND A TOUGH PVC SHIELDED CABLE, THE STYLUS REACH IS BUILT TO ILLUMINATE THOSE UNFORGIVING, HARD-TO-REACH AREAS. IT FEATURES AN UNBREAKABLE, 100,000 HOUR LED.

STOCK NO. STR65618

## STYLUS "AAAA" BATTERIES



STOCK NO. STR65030

## SCORPION FLASHLIGHT



COMPACT, LITHIUM POWERED FLASHLIGHT. ONLY 4.9" LONG AND 4.4 OZ.. XENON BULB PROVIDES UP TO 6,500 CANDLEPOWER. RUBBER-ARMORED SLEEVE OVER ALUMINUM BODY. SPARE BULB INCLUDED. USES (2) 3 VOLT LITHIUM BATTERIES.

STOCK NO. STR85001

## SCORPION REPLACEMENT BULB

STOCK NO. STR85914

## SCORPION BLACK NYLON HOLSTER



STOCK NO. STR85905

## 3V LITHIUM BATTERIES

STOCK NO. STR85175



## POLYMER FLASHLIGHT

YOU WON'T FIND A MORE EASY-TO-USE 4AA FLASHLIGHT. IT'S ERGONOMICAL SHAPE AND PUSH-BUTTON SWITCH OFFER ONE-HANDED OPERATION.

### 4AA XENON



UP TO 6000 CANDLEPOWER. A RUN TIME UP TO 4 HOURS.

STOCK NO. STR68002

### 3C 10-LED



FEATURES TEN SUPER-BRIGHT, 100,000 HOUR LEDS. A RUN TIME UP TO 336 HOURS.

STOCK NO. STR33202

**IF YOU DON'T SEE  
SOMETHING  
HERE YOU NEED.  
GIVE US A CALL.  
WE WILL DO  
OUR BEST  
TO FIND IT FOR YOU.**

## 2D TWIN TASK LIGHT



FEATURES A PATENTED LED/XENON COMBINATION WHICH ALLOWS YOU TO CHOOSE BETWEEN AND EXTRAORDINARY RUN TIME AND A BLINDING BRIGHT LIGHT. MICRO-FACETED REFLECTOR FOR A SMOOTH, PERFECTLY FOCUSED BEAM THAT IS ADJUSTABLE. OFFERS AN ENHANCE KNURL GRIP AND AN UNBREAKABLE POLYCARBONATE LENS.

STOCK NO. STR51001

## STINGER HP



THE STINGER HAS LONG BEEN KNOWN AS THE MOST POWERFUL RECHARGEABLE FLASHLIGHT THERE IS FOR ITS SIZE. THE H P STANDS FOR HIGH PERFORMANCE. THIS HIGH POWERED STINGER IS ONLY 8-1/4" LONG AND WEIGHS 12.2 OZ. WITH IT'S ENHANCED 40,000 CANDLEPOWER LIGHT IT HAS ALMOST THREE TIMES THE CANDLEPOWER OF THE ORIGINAL. FEATURES A MACHINED ALUMINUM CASE, AN ADJUSTABLE FOCUS AND A 1 HOUR RUN TIME. 10 HOUR SNAP-IN CHARGER HOLDER, 2.5 HOUR FAST CHARGER HOLDER OR PIGGYBACK CHARGER HOLDER AVAILABLE.

STOCK NO. STR75503

## ULTRA STINGER



INCLUDES A NICKEL-CADMIUM, 3.6 VOLT, RECHARGEABLE BATTERY THAT CAN BE RECHARGED UP TO 1000 TIMES. AN AMAZING 75,000 CANDLEPOWER. VIRTUALLY INDESTRUCTIBLE MACHINED ALUMINUM HOUSING WITH AN UNBREAKABLE POLYCARBONATE LENS. HAS 1 HOUR OF CONTINUOUS USE BETWEEN CHARGES.

STOCK NO. STR78001 (AC CHARGER)  
STOCK NO. STR78014 (AC/DC CHARGER)

## ULTRA STINGER REPLACEMENT BULB

STOCK NO. STR78914

## ULTRA STINGER BATTERY PACK



STOCK NO. STR77175

**STREAMLIGHT**

**SL-20X**



THE POLICE OFFICER'S STANDARD FOR OVER 20 YEARS, THE RECHARGEABLE SL-SERIES OFFERS UNMATCHED POWER FOR THIS SIZE. THIS 13" LIGHT OFFERS UP TO 30,000 AND 25,000 CANDLEPOWER FROM MACHINED ALUMINUM. RUN TIMES ARE ABOUT 1.5 HOURS BETWEEN CHARGES. LENS IS UNBREAKABLE POLYCARBONATE. THIS LIGHT CAN BE CHARGED UP TO 1000 TIMES.

STOCK NO.	CHARGER	COLOR
STR26120	DC	BLACK

**BATTERY PACKS**



STOCK NO.	LIGHT MODEL	STYLE
STR20170	SL-20X	A
STR25170	SL-20XP	B

**SWITCH MODULES**



REPLACEMENT SWITCH FOR THE SL-20 MODEL SERIES.

STOCK NO.	STR20140
-----------	----------

**CHARGE SLEEVE ASSEMBLY**



STOCK NO.	STR22052
-----------	----------

"I HAVE TO CUT DOWN ON HOT DOGS AND BEER," ONE BLEACHER BUM SAID TO ANOTHER. "WHY'S THAT?" "CAN'T YOU SEE? I'M STARTING TO GET A BALLPARK FIGURE."

**LED 3AA LUXEON TASK LIGHT**



LUXEON LED 10 TIMES BRIGHTER THAN A HIGH-INTENSITY LED. LONGEVITY OF AN LED WITH THE BRIGHTNESS OF A CONVENTIONAL BULB. THE BULB IS A LUXEON STAR, ONE WATT, 10,000-HOUR LED. COMPUTER MACHINED ALUMINUM WITH ANODIZED FINISH AND UNBREAKABLE POLYCARBONATE LENS. USES (3) AA ALKALINE BATTERIES. ALSO WATER RESISTANT; O-RING SEALED; ENHANCED KNURLED GRIP; LANYARD INCLUDED.

STOCK NO.	STR51006
-----------	----------

**ARGO**



ARGO LUXEON LED HEADLAMP FEATURES A STATE-OF-THE-ART LUXEON LED, SO YOU GET THE LONGEVITY OF AN LED AND THE BRIGHTNESS AND RANGE OF A CONVENTIONAL BULB. REMARKABLY EFFICIENT AND LIGHTWEIGHT, IT OFFERS 3 DIGITALLY CONTROLLED BRIGHTNESS LEVELS AND A FLASHING MODE FOR EMERGENCY SIGNALING. PLUS THE ARGO IS DIGITALLY CONTROLLED, SO IT REGULATES ITS OUTPUT TO MAINTAIN CONSISTENT LEVELS OF LIGHT. IT ALSO FEATURES AN INDICATOR THAT SHOWS ITS REMAINING BATTERY POWER. USES (3) AAA ALKALINE BATTERIES. THE 10,000 HOUR LED NEVER NEEDS REPLACING. IT INCLUDES ADJUSTABLE STRAPS FOR A COMFORTABLE SECURE FIT.

STOCK NO.	STR61301
-----------	----------

**TRIDENT**



FOR THE ULTIMATE IN CONVENIENCE, SAFETY, AND DEPENDABILITY, USE THE HANDS-FREE TRIDENT HEADLAMP. THE TRIDENT IS TRULY UNIQUE BECAUSE IT COMBINES A SUPER-BRIGHT KRYPTON BULB WITH 3 LED'S, GIVING YOU HIGH POWER AND LONGEVITY. THIS LIGHTWEIGHT HEADLAMP FEATURES 3-WAY LIGHTING FOR SHORT, MEDIUM AND LONG DISTANCES. PLUS, WITH A DURABLE DESIGN AND A BATTERY LIFE OF MORE THAN 150 HOURS. USES (3) AAA ALKALINE BATTERIES. LIGHTWEIGHT, THERMOPLASTIC CONSTRUCTION AND ELASTIC HEADSTRAP.

STOCK NO.	STR61000
-----------	----------

**SEPTOR**



LED HEADLAMP WITH ELASTIC STRAP. FEATURING (7) SEVEN ULTRA BRIGHT LED'S WITHIN THE REFLECTOR. WEIGHING ONLY 5 OZ. MAKES THIS WATER RESISTANT LIGHT WEIGHT THERMOPLASTIC CONSTRUCTION IDEAL FOR USES OUTDOOR, SPORTING GOODS, AUTOMOTIVE, ETC. USES (3) AAA ALKALINE BATTERIES. WITH A 100,000 HOUR LIFE, THE UNBREAKABLE POLYCARBONATE LENS HELPS SECURE ITS LONGEVITY.

STOCK NO.	STR61007
-----------	----------

**RUBBER HARDHAT STRAP**



OFFERED AS AN ALTERNATIVE THIS RUBBER HEAD-STRAP ENSURES A NON-SLIP FIT FOR HARDHATS.

STOCK NO.	STR61003
-----------	----------

### STREAMLIGHT

#### VULCAN



THE WORLD STANDARD IN RECHARGEABLE LANTERNS. FEATURING BI-PIN BULBS PROVIDING VERY POWERFUL OUTPUTS, PLUS VERY LONG RUN TIMES, VIRTUALLY UNBREAKABLE CASES AND CHARGING/ MOUNTING RACKS WHICH MEET NFPA REQUIREMENTS. GENERATES 40,000 CANDLEPOWER. AVAILABLE IN STANDARD, VEHICLE MOUNT OR DUAL FILAMENT VERSIONS. FACTORY MUTUAL APPROVED. 8 WATT.

STOCK NO. STR44000 (AC/DC)

#### CHARGING RACK

STOCK NO. STR44100

#### LITEBOX



THE WORLD STANDARD IN RECHARGEABLE LANTERNS. FEATURING BI-PIN BULBS PROVIDING VERY POWERFUL OUTPUTS, PLUS VERY LONG RUN TIMES, VIRTUALLY UNBREAKABLE CASES AND CHARGING/ MOUNTING RACKS WHICH MEET NFPA REQUIREMENTS. UP TO 70,000 CANDLEPOWER AND 10 HOURS RUN TIME. AVAILABLE IN STANDARD, VEHICLE MOUNT OR DUAL FILAMENT VERSIONS.

STOCK NO. WATT COLOR MOUNT

STR45107	8W SPOT	ORANGE	DC DIRECT
STR45108	8W SPOT	YELLOW	DC DIRECT
STR45117	8W SPOT	YELLOW	AC/DC
STR45113	20W FLOOD	YELLOW	AC/DC

#### SPOT LAMP ASSEMBLY



CAN BE USED IN THE LITEBOX AND THE VULCAN TO CHANGE FROM A FLOOD TO A SPOT LIGHT OR AS A REPLACEMENT.

STOCK NO.STR45911

**SAVE TIME AND MONEY**

**TO SAVE OUR CUSTOMERS THE DELAY AND BOTHER OF HUNTING THROUGH MANY SOURCES OF SUPPLY, WE CAN FURNISH MANY ITEMS NOT LISTED IN THIS CATALOG**

#### LITEBOX BATTERY

STOCK NO. STR45937



**CALL FOR COMPLETE SPECIFICATIONS AND PRICES!**

*OVER 30,000 INVENTORY ITEMS IN STOCK!*



**CUSTOMER SATISFACTION IS THE KEY TO OUR SUCCESS**

**WORK LIGHTS**

**250W HALOGEN CLAMP-ON LIGHT**



FEATURES A HEAVY DUTY STEEL YOKE WITH ADJUSTABLE PIVOTING HEAD.

STOCK NO. WLL850

**250W HALOGEN WORKLIGHT**

DIE-CAST ALUMINUM HOUSING. WEATHERPROOF CONSTRUCTION. TILT CONTROL. HEAVY DUTY STEEL STAND.



STOCK NO. WLL860BB

**500W PORTABLE WORKLIGHT**



DIE-CAST ALUMINUM HOUSING. WEATHERPROOF CONSTRUCTION. TILT CONTROL. HEAVY DUTY STEEL STAND.

STOCK NO. WLL18

**500W HALOGEN LIGHT WITH SWITCH**



ADJUSTABLE PIVOT HANDLE. WEATHERPROOF ON/OFF SWITCH. SAFETY WIRE GUARD. HEAVY DUTY ALUMINUM FIXTURE AND YELLOW COLOR FOR SAFETY.

STOCK NO. WLL33

**1000W 160 DEGREE WIDE ANGLE WALL TO WALL PORTABLE WORKLIGHT**



USES THREE 500 WATT HALOGEN BULBS. PATENTED DESIGN LIGHTS UP TO 160 DEGREES PER HEAD. HINGED STYLE FACE FRAME. WEATHERPROOF ON/OFF SWITCHES. EXTRA BULB STORAGE TUBE. LIMITED 5 YEAR WARRANTY. UL AND CUL LISTED.

STOCK NO. WLL5203

**500W HALOGEN LAMP WALL MOUNT**



HEAVY DUTY WIRE GRILL. TEMPERED GLASS LENS. ADJUSTABLE ARM EXTENDS FROM WALL 40". WITH AN ON/OFF SWITCH. WITH EXTRA BULB STORAGE TUBE. GROUNDED CORD.

STOCK NO. WLL41

**1500 WATT DOUBLE BULB HALOGEN 2-N-1 TRIPOD WORKLIGHT**



PROFESSIONAL GRADE CONSTRUCTION. USES A 250 WATT AND A 500 WATT BULB, FOR 750 WATTS PER HOUSING, 1500 WATTS TOTAL. HINGED STYLE FACE FRAME. SLED BASE AND TRIPOD BASE INCLUDED. TELESCOPES FROM 40 INCHES TO 76 INCHES WITH EASY GRIP LOCKING NUTS. ADJUSTABLE EXTENSION LEG FOR USE ON UNEVEN SURFACES. WIRE CORD STORAGE BRACKETS ON LEG. WEATHERPROOF ON/OFF SWITCHES. COMPLETE WITH THREE 500 AND THREE 250 WATT HALOGEN BULBS. LIMITED LIFETIME WARRANTY. UL AND CUL LISTED.

STOCK NO. WLL5402

**600W DOUBLE BULB HALOGEN 2-N-1 TRIPOD POWER LIGHT**



HEAVY DUTY CONSTRUCTION. USES TWO 300 WATT BULBS FOR 600 WATT TOTAL. HINGED STYLE FACE FRAMES. SLED BASE AND TRIPOD BASE INCLUDED. TELESCOPES FROM 40 INCHES TO 76 INCHES WITH EASY GRIP LOCKING NUTS. WIRE CORD STORAGE BRACKETS ON LEG. WEATHERPROOF ON/OFF SWITCHES. LIMITED 5 YEAR WARRANTY. UL AND CUL LISTED.

STOCK NO. WLL5301

HALOGEN REPLACEMENT BULB

STOCK NO. WLL32 WATT RATING 600W

**1000W DUAL HALOGEN WORKLIGHT WITH ADJUSTABLE STAND**



DUAL HEAD PORTABLE FLOODLIGHT. TWIN BEAM. 1,000 WATT, QUARTZ HALOGEN WITH TRIPOD. USES 2 500W HALOGEN LIGHT BULBS.

STOCK NO. WLL14

**1000W DUAL HALOGEN WORKLIGHT WITH ADJUSTABLE STAND**



TEMPERED GLASS LENS. BLACK WIRE GRILL. INDIVIDUAL PUSH BUTTON ON/OFF SWITCHES. "EASY GRIP" WIDE LOCKING NUTS. HEAVY DUTY TRIPOD STYLE BRACES. WIRE CORD STORAGE BRACKETS. USES 2 500W HALOGEN LIGHT BULBS.

STOCK NO. WLL11

**REPLACEMENT HALOGEN BULBS**



STOCK NO.	WATT RATING
WLL32	600W
WLL95150W	150W
WLL96250W	250W
WLL16500W	500W
<b>ROUGH SERVICE HALOGEN REPLACEMENT BULBS</b>	
WLL716500W	500W

**BULB BUDDY**



THIS HEAVY DUTY, UNBREAKABLE CASE STORES UP TO 6 HALOGEN BULBS FROM 100 TO 600 WATT. HELPS PROTECT AGAINST DAMAGE WHEN IN YOUR TOOLBOX OR BIN.

INCLUDES 6 500W-120 VOLT QUALITY 2000 HOUR HALOGEN BULBS.

STOCK NO. WLL1500W

**HAVING TROUBLE FINDING SOMETHING?**

**GIVE US A CALL. WE WILL BE MORE THAN HAPPY TO ASSIST YOU**

**WORK LIGHTS AND BULBS**

**COOL WHITE FLUORESCENT TUBES**



STOCK NO.	LGTH.	PROD.	BASE NO.	WATTS	CTN. QTY.
LB01	48"	F40CW	MED BI-PIN	34	30
LB11	48"	F32T8/41K	MED BI-PIN <i>(SMALL "O.D.")</i>	32	30
LB02	96"	F96T12CW	SING. PIN	60	15
LB03	96"	F96T12CW	REC.	95	15
LB04	96"	F96T12CW	REC.	215	15

**ROUGH SERVICE BULBS**

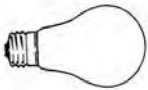

TAKES THE EXTRA ABUSE OF INDUSTRIAL AND MAINTENANCE APPLICATIONS. EXTRA STRONG FILAMENT. LONGER LIFE.

STOCK NO.	WATT RATING	VOLT RATING	STD. PACK
AP50RS	50W	120	2
AP75RS	75W	120	2
LB18	75W	130	4
AP100RS	100W	120	2
LB19	100W	130	4
<b>TOUGH SKIN COATED BULBS</b>			
LB21	75W	130	1
AP75TS	75W	125	2
LB22	100W	130	1
LB23	150W	130	1

**INCANDESCENT BULBS**



STOCK NO.	WATT RATING	VOLT RATING	STD. PACK
LB10	40	130	4
LB11	60	130	4
LB12	75	130	4
LB13	100	130	4
LB14	150	130	6
LB15	200	130	1

**FLUORESCENT BULB**

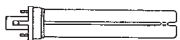

STOCK NO.	WATT RATING
WLL713	13W

\*FITS HAND HELD FLUORESCENT LIGHT WLL1796

**18" FLUORESCENT DROP LIGHT BULB**



STOCK NO.	WATT RATING
MDF15T8CW	15W

**FLOOD AND REFLECTOR BULBS**



STOCK NO.	DESCRIPTION	PROD. NO.	WTS.	VTS.
MD160119	HALOGEN FLOOD W/ HEAVY GLASS	PAR38	90	120
MD150PAR	FLOOD W/ STD. GLASS	PAR38	150	120
MD75WR30	REFLECTOR*	BR30	65	120

\*REFLECTOR BULBS - FOR INDOOR USE

**CLEAR REPLACEMENT AUTO BULBS**

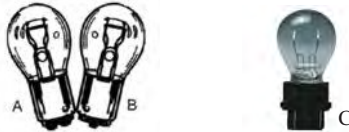

STOCK NO.	ILLUSTRATION TYPE	VOLTAGE	CANDLE POWER
AP194*	N/A	12	N/A
AP1157	A	12	32/3
AP1156	B	12	32
AP3156	C	12	32
AP3157	C	12	32

\*MINIATURE BULB UNIT PACKAGE - 10

**MERCURY VAPOR BULB**



TO BE USED ONLY IN MERCURY VAPOR FIXTURES. DO NOT INTERCHANGE LAMP WATTAGES.

STOCK NO.	WATT RATING	STD. PACK
LB27	175	1

**3-WAY SOFT WHITE LIGHT BULB**

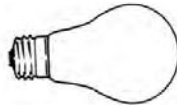

STOCK NO.	WATT RATING	STD. PACK
LB25	50, 100, 150	1

**ENERGY SAVING SLIMLINE BALLASTS**



STOCK NO.	VOLTAGE	LAMPS	SIZE
LB07	120	2	4FT.
LB08	120	2	8FT.

**METAL HALIDE BULB**



CONSTRUCTED OF AN OUTER BULB WITH AN INTERNAL ARC TUBE MADE OF QUARTZ. THE ARC TUBE OPERATES UNDER HIGH PRESSURE AT VERY HIGH TEMPERATURES.

STOCK NO.	WATT RATING	APPROX. OVERALL LENGTH	STD. PACK
LB34	250W	8-5/16"	1
LB35	400W	11"	1
LB36	1000W	11"	1

**METAL HALIDE BULB**



USUALLY USED IN WALL PATH LIGHTS. CONSTRUCTED OF AN OUTER BULB WITH AN INTERNAL ARC TUBE MADE OF QUARTZ. THE ARC TUBE OPERATES UNDER HIGH PRESSURE AT VERY HIGH TEMPERATURES.

STOCK NO.	WATT RATING	APPROX. OVERALL LENGTH	STD. PACK
LB34	400W	8-5/16"	1

**HI-PRESSURE SODIUM BULB**



TYPE A

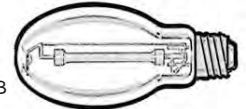

TYPE B

PROVIDES SOFT YELLOW LIGHT. DO NOT INTERCHANGE LAMP WATTAGES.

STOCK NO.	ILLUSTRATION TYPE	WATT RATING
LB40	A	70W
LB41	A	100W
LB42	A	150W
LB45	B	400W
LB46	B	1000W

**U-TUBE FLUORESCENT BULB**



STOCK NO.	PROD	BASE RATING	WATT QTY.
LBU6	F40CW	MED BI-PIN	34

**EXIT SIGN BULB**



STOCK NO.	BULB	BASE	WATT RATING
LB51	T6	CANDELABRA	15

**BULBS, WORK LIGHTS AND SPOTLIGHTS**

**COMPACT FLUORESCENT BULBS**



STOCK NO.	WATT RATING	INCANDESCENT WATT EQUIVALENT	STD. PACK
LBF1 (MINI)	23W	100	1
LBF101 (MINI)	25W	100	1
LBF103 (MINI)	30W	125	1
LBF104	40W	200	1
LBF105	65W	300	1

**COMPACT FLUORESCENT R30 REFLECTOR BULB**



STOCK NO.	WATT RATING	INCANDESCENT WATT EQUIVALENT	STD. PACK
LBF115	15W	60	1

**32W FLUORESCENT BULB**



COMPACT FLUORESCENT TWIST BULB. 150 WATT REPLACEMENT USING ONLY 32 WATTS. INSTANT ON, NO FLICKER. 10000 HOURS. ELECTRONIC.

STOCK NO.	WATT RATING	INCANDESCENT WATT EQUIVALENT	STD. PACK
LBF11	32W	150	1

THIS IS A COMPREHENSIVE CATALOG OF OUR MAJOR LINES AND SERVICE, BUT IT DOES NOT SHOW ALL AVAILABLE PRODUCT LINES. IF THERE IS SOMETHING YOU NEED THAT IS NOT SHOWN, WE EITHER CARRY IT OR CAN GET IT. PLEASE CALL US FOR INFORMATION.

**KING SWING ARM LIGHT**



100-WATT INCANDESCENT LAMP (NOT INCLUDED), 34" REACH, EDGE CLAMP INCLUDED. "EASY-DIAL" ON/OFF SWITCH.

STOCK NO. LUXL421

**ADJUSTABLE MACHINE AND BENCH WORK LIGHTS**



NARROW 4-5/8" BULLET SHADE CONCENTRATES LIGHT OUTPUT FROM A 60 WATT BULB (INCLUDED). VENTED SHADE WITH INNER REFLECTOR STAYS COOL. 3 CONDUCTOR THERMOPLASTIC CORD. MOLDED PLUG. VERSATILE "A" BRACKET. GRAY COLOR.

STOCK NO. LUXLB1A (45" REACH)  
STOCK NO. LUXLB2A (30" REACH)

**HEAVY DUTY MAGNIFIER**



42" ARM. CLAMP-ON 220 WATT CIRCLINE FLUORESCENT LAMP, 3-CONDUCTOR CORD SET, 3-DIOPTER LENS. FOR WEIGHTED TABLE BASE.

STOCK NO. LUXL712

**ADDITIONAL WORK LIGHTS AVAILABLE UPON REQUEST**

AT A WASHINGTON COCKTAIL PARTY, TWO STRANGERS STRUCK UP A CONVERSATION. AFTER A FEW MINUTES OF SMALL TALK, ONE SAID, "HAVE YOU HEARD THE LATEST WHITE HOUSE JOKE?"  
"THE SECOND FELLOW HELD UP HIS HAND. "WAIT, BEFORE YOU BEGIN, I SHOULD TELL YOU THAT I WORK IN THE WHITE HOUSE."  
"OH, DON'T WORRY," THE FIRST MAN REPLIED. "I'LL TELL IT VERY SLOWLY."

**HI-BEAM SPOTLIGHT**



BUILT-IN FINGERTIP ON/OFF SWITCH. PLUGS INTO 12V CIGARETTE LIGHTER. 10 FT. RETRACTABLE COILED CORD. COMPLETE WITH MOUNTING BRACKET AND SCREWS. FOR AUTOMOTIVE/ RECREATIONAL VEHICLES AND MARINE USE. 1,000,000 CANDLE POWER AT 16V.

STOCK NO. APMM450

**REFLECTOR LIGHTS WITH CLAMP**



FOSCL75



FOSCL300

VERSATILE MULTI-USE UTILITY LAMPS WITH SPUN ALUMINUM REFLECTOR. RUBBER PROTECTED SPRING CLAMP BASE WITH BALL JOINT. USE IN NON-HAZARDOUS WORK AREAS.

STOCK NO.	DESCRIPTION
FOSCL75	PHENOLIC SOCKET, ALUMINUM SCREW SHELL, 6 FT. 18/2 CORD. UL LISTED FOR 150 WATTS.
FOSCL300	DEEP REFLECTOR AND CERAMIC SOCKET WITH COPPER SCREW SHELL; 8FT. 18/3 CORD. UL LISTED FOR 300 WATTS.

BOTH UNITS OPERATE ON 120V, 60 HZ. FOR INDOOR USE ONLY. BULBS NOT INCLUDED.

**POLAR TROUBLE-LIGHTS**



POLAR SOLAR CORD HEAVY DUTY USE ONE PIECE INJECTION MOLDED HANDLE GROUNDED METAL GUARD, SWITCH, & SIDE OUTLET.

STOCK NO.	WIRE GA.	WIRE TYPE	LGTH. (FT.)	CORD COLOR	125V RTG.
EC05857	16/3	SJEO	25'	YELLOW	13A
EC05858	16/3	SJEO	50'	YELLOW	13A

REPLACEMENT TROUBLE-LIGHT GUARDS  
STOCK NO. EC05906 (METAL SWING-OPEN)

**WORK LIGHT STREAMER**



(BULB NOT INCLUDED)

STOCK NO. EC07308 (14/2 x 50')

### WORK LIGHTS

#### FLUORESCENT WORK LIGHT



CAPABLE OF WALL OR CEILING MOUNTING. GIVES LUMENS OF LIGHT OF APPROXIMATELY 75 WATTS WHILE SAVING ENERGY. 6 FOOT GROUND CORD IN HIGH VISIBILITY YELLOW COLOR FOR SAFETY.

STOCK NO. WLL1796

REPLACEMENT BULB STOCK NO. WLL713

#### THE ANGLE LIGHT



THE PREMIER FLUORESCENT LIGHT IN THE INDUSTRY. WITH A 50 FT., 16/3 OIL AND WATER-RESISTANT CORD, THIS LIGHT DOUBLES AS AN EXTENSION CORD WITH A 110 VOLT POWER OUTLET. COMES WITH MAGNET MOUNT.

STOCK NO. NEM70050

REPLACEMENT BULB STOCK NO. WLL713

#### COMPACT WORK LIGHT

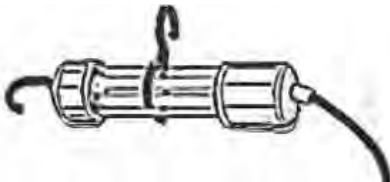

FITS IN THOSE TIGHT CONSTRICTED AREAS WITH LIMITED ACCESS. WILL GIVE 60 WATTS OF LIGHT FROM A 13-WATT BULB. 50 FT. CORD IS 18/2 GAUGE - OIL AND WATER RESISTANT.

STOCK NO. NEM80050

REPLACEMENT BULB STOCK NO. WLL713

#### CORDLESS RECHARGEABLE LED WORK LIGHTS

SUPER BRIGHT LED BULBS. A/C WALL CHARGER AND D/C 12V ADAPTER INCLUDED. 360° SWIVEL HOOK. FLAT RING SURFACES PREVENT ROLLING ON FLAT SURFACES. RECHARGEABLE 7.2 Ni-Mh BATTERY. AUTOMATIC OVERCHARGE PROTECTION. HIGH IMPACT DESIGN.



STOCK NO. WLL1790 (30 LED)

STOCK NO. WLL1791 (60 LED)



STOCK NO. WLL1793

30 SUPER BRIGHT 100,000 HOUR FLOODLIGHT STYLE LEDS. UNIQUE ABS CASE. BATTERY PACK HAS 1000 CHARGE CYCLES. 10 HOUR CORDLESS USE BETWEEN CHARGING. "SMART" BATTERY CHARGER WON'T OVERCHARGE. SUPER STRONG SWIVEL HOOK KEEPS LIGHT ON THE SUBJECT, NOT IN YOUR EYES. POWERED BY RECHARGEABLE NiMh BATTERY PACK. PROTECTIVE GRIP AND GUARDS.

#### MULTI-USE FLUORESCENT WORK LIGHT



A MULTI-USE LARGE 15-WATT LIGHT WITH APPLICATIONS IN AUTO, MACHINE SHOPS AND HOME. 50 FT. CORD IS 18/2 GAUGE OIL AND WATER RESISTANT. COMES WITH THREE HOOKS AS PICTURED.

STOCK NO. NEM90050

REPLACEMENT BULB STOCK NO. MDF15T8CW

#### SCREW-IN FLUORESCENT LIGHT



THE CONVERTIBLE REPLACES ANY HOT DANGEROUS INCANDESCENT "TROUBLE" LIGHT WITH A COOL RUNNING SAFE FLUORESCENT WORK LIGHT. REPLACES ALL INCANDESCENT LIGHTS INCLUDING CORD REELS. 60 WATTS OF LIGHT FROM A 13-WATT BULB.

STOCK NO. NEM40001

REPLACEMENT BULB STOCK NO. WLL713

#### PLUG-IN FLUORESCENT LIGHT



AN EXTENSION CORD INSTANTLY CONVERTS TO A 13-WATT FLUORESCENT WORK LIGHT WHEN PLUGGED INTO THIS LIGHT. COMPACT DESIGN INSTALLS IN SECONDS WITH "NO PULL OUT" CORD STOP.

STOCK NO. NEM40007

REPLACEMENT BULB STOCK NO. WLL713

#### FLUORESCENT ANGLE REEL LIGHT



ANGLE LIGHT WITH TOOL TAP AND 10 AMP CIRCUIT BREAKER. 50 FT. OF 16/3 CORD - OIL AND WATER RESISTANT.

STOCK NO. NEM20750

REPLACEMENT BULB STOCK NO. WLL713

#### 15 WATT FLUORESCENT REEL LIGHT



THIS REEL SHARES MANY OF THE SAME BENEFITS AS THE 13 WATT HEAVY DUTY REEL. COMPONENTS ENCLOSED TO PROVIDE DIRT AND GREASE-FREE OPERATION. COMES WITH 50 FT. OF OIL AND WATER-RESISTANT CORD AND 3 HOOKS.

STOCK NO. NEM20950

REPLACEMENT BULB STOCK NO. MDF15T8CW

#### TRIPLE TAP HEAVY DUTY EXTENSION CORD REEL



OIL AND WATER RESISTANT CORD WITH 3 OUTLETS. 10 AMP CIRCUIT BREAKER PREVENTS ACCIDENTAL OVERLOAD.

STOCK NO. SIZE  
NEM12T40 40 FT X 12/3  
NEM23T50 50 FT X 16/3

ADDITIONAL ITEMS AVAILABLE UPON REQUEST



**ELECTRICAL EXTENSION CORDS, GROUND FAULT CIRCUIT INTERRUPTERS  
AND CONNECTORS**

*POLAR SOLAR CORD IS THE ALL PURPOSE OUTDOOR CORD THAT ALWAYS STAYS LIGHT AND FLEXIBLE, EVEN UNDER THE MOST EXTREME CONDITIONS. MAINTAINS TOTAL FLEXIBILITY TO -67°F. RUGGED T-PRENE INSULATION IS RESISTANT TO OIL, GREASE, ACIDS, SOLVENTS, PLUS OUTSTANDING ABRASION RESISTANCE. UL LISTED. MEETS OSHA REQUIREMENTS.*

**POLAR SOLAR EXTENSION CORD**



DOUBLE INSULATED, INDOOR OR OUTDOOR USE. HEAVY DUTY MOLDED-ON PLUGS AND CONNECTORS. WITH POWER INDICATOR LIGHT.

**THREE CONDUCTOR 300 VOLT**

STOCK NO.	WIRE GA.	LGTH (FT.)	CORD COLOR	125V RTG.
EC01487	14/3	25'	YELLOW	15A
EC01488	14/3	50'	YELLOW	15A
EC01489	14/3	100'	YELLOW	13A
EC01687	12/3	25'	YELLOW	15A
EC01688	12/3	50'	YELLOW	15A
EC01689	12/3	100'	YELLOW	15A
EC01788	10/3	50'	YELLOW	15A
EC01789	10/3	100'	YELLOW	15A

**POLAR SOLAR QUADNECTOR**



THE VERSATILITY OF 4-WAY POWER COMBINED WITH THE RUGGED DURABILITY OF POLAR SOLAR CORD AND ALL WEATHER FLEXIBILITY. WITH POWER INDICATOR LIGHTS.

STOCK NO.	WIRE GA.	LGTH. (FT.)	CORD COLOR	125V RTG.
EC04422	12/3	6'	YELLOW	15A
EC04427	12/3	25'	YELLOW	15A
EC04428	12/3	50'	YELLOW	15A
EC04429	12/3	100'	YELLOW	15A



**HEAVY-DUTY GENERAL PURPOSE  
EXTENSION CORD**



UL LISTED. MEET OSHA REQUIREMENTS FOR OUTDOOR USE. HIGH VISIBILITY ORANGE VINYL INSULATION RESISTS OIL, GREASE, MOISTURE, ABRASION AND PROLONGED EXPOSURE TO SUNLIGHT. HEAVY DUTY MOLDED-ON PLUGS AND CONNECTORS.

STOCK NO.	WIRE GA.	LENGTH (FT.)
EC02407	14/3	25'
EC02408	14/3	50'
EC02409	14/3	100'

**LIGHTED ENDS**

EC02587	12/3	25'
EC02588	12/3	50'
EC02589	12/3	100'

**TRIPLE SOURCE POWER BLOCK**



THREE WAY POWER BLOCKS WITH POWER INDICATOR LIGHTS. ALL-WEATHER T-PRENE JACKET.

STOCK NO.	WIRE GA.	LGTH (FT)
EC03488	12/3	50'

**OUR  
COURTEOUS  
STAFF IS READY  
TO TAKE YOUR  
CALLS. IT IS OUR  
PLEASURE TO  
ASSIST YOU.**

**HEAVY DUTY IN-LINE GFCI**

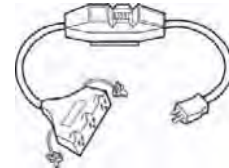

15 AMP, 120 VOLT, RUGGED-DUTY IN-LINE WITH MOLDED MALE END AND TRI-SOURCE RECEPTACLE. 30 INCHES.

STOCK NO.	WIRE GA.
EC02841	12/3

**DUPLEX BOX**



RUGGED HEAVY-DUTY, WEATHERPROOF BOX MADE FROM GE NORYL RESIN. BUILT WITH HEAVY-DUTY 25 AMP RELAY. BUILT FOR TOUGH LOADS. DUPLEX BOX, 15 AMP GFCI WITH TEST AND RESET BUTTONS.

STOCK NO.	EC02822
-----------	---------

**POWER PLUG UNITS**



GFCI PLUG UNIT WITH THE FLEXIBILITY OF FULL LENGTH TRI-SOURCE EXTENSION CORDS. THESE CORDS ARE MADE OF 12 GAUGE CONTRACTOR-GRADE POLAR SOLAR CABLE WITH MOLDED TRI-SOURCE THREE-WAY RECEPTACLE. GFCI UNIT IS RAINPROOF.

STOCK NO.	LENGTH IN FT.
EC02832	2'

**WE ARE HERE  
FOR YOU!**

### ELECTRICAL EXTENSION CORDS AND CONNECTORS

#### HEAVY DUTY 4-OUTLET POWER BLOCK

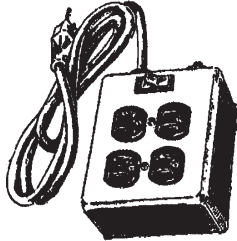

15 AMP HEAVY DUTY RATED FOR 1875 WATT CAPABLE OF RUNNING YOUR HEAVY DUTY TOOLS OR EQUIPMENT. SAFETY OVERLOAD CIRCUIT BREAKER WILL TRIP IF OVERLOADED, FOR YOUR SAFETY. LIGHTED SWITCH SHOWS AT A GLANCE THAT YOUR FOUR OUTLETS ARE ON AND FUNCTIONING.

STOCK NO. WLL814

#### POWER STRIPS



STOCK NO.	DESCRIPTION
SHAUL207BC	7 OUTLET - 6 FT.

ADDITIONAL FIXTURES AND ELECTRICAL EQUIPMENT AVAILABLE UPON REQUEST

#### TRI-TAP ADAPTER



UL LISTED - 15A - 125V  
3 WIRE CUBE TAP. NEOPRENE.

STOCK NO. EC09903

#### BULK CORD

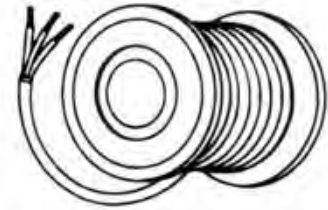

STOCK NO.	WIRE GA.	WIRE TYPE	LGTH. (FT.)	CORD COLOR	125V RTG.
EC233271	14/3	SJEOW-A	250'	BLACK	15A

#### CONNECTORS AND PLUGS



UL LISTED - 15A - 125V

ARMORED MALE CAP. 3 WIRE DEAD FRONT, YELLOW VINYL. TAKES 12/3 AND SMALLER WIRE.  
STOCK NO. EC05980

ARMORED FEMALE CONNECTOR. 3 WIRE DEAD FRONT, YELLOW VINYL. TAKES 12/3 AND SMALLER WIRE.  
STOCK NO. EC05981

#### HEAVY DUTY ELECTRICAL PLUGS



STOCK NO.	DESCRIPTION
EC05990	MALE ELECTRICAL PLUG
EC05991	FEMALE ELECTRICAL PLUG

SERVICE AS YOU WANT IT...

OUR ORGANIZATION IS GEARED TO SERVE YOU PROMPTLY AT ALL TIMES. WE SPARE NO EFFORTS IN HELPING OUR CUSTOMERS GET DELIVERY AS THEY NEED IT. YOU CAN DEPEND ON US.

**WIRE TERMINALS**

**BUTT CONNECTORS**

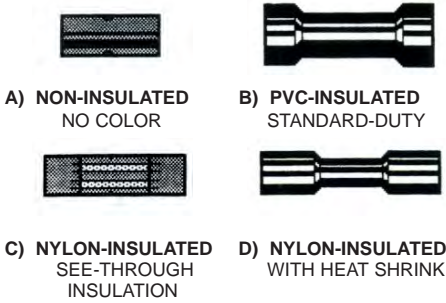

STOCK NO.	WIRE GAUGE	INSUL. COLOR	TYPE	BOX QTY.
3M072	18-22	-	A	100
3M100	14-16	-	A	100
3M150	10-12	-	A	100
3M183	#8	-	A	100
3M190	#6	-	A	100
3M211	#4	-	A	50
3M216	#2	-	A	25
3M2270	1/0	-	A	25
3M2280	2/0	-	A	25
3M001	18-22	RED	B	100
3M020	14-16	BLUE	B	100
3M050	10-12	YELLOW	B	100
3M0015	18-22	RED	C	100
3M021	14-16	BLUE	C	100
3M051	10-12	YELLOW	C	100
3M332	18-22	RED	D	25
3M333	14-16	BLUE	D	25
3M334	10-12	YELLOW	D	25

**SPADE TERMINALS**

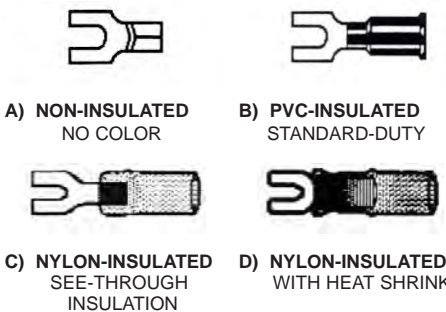

STOCK NO.	WIRE GAUGE	HOLE SIZE	INSUL. COLOR	TYPE	BOX QTY.
3M0728	18-22	4-6	-	A	100
3M073	18-22	8-10	-	A	100
3M110	14-16	4-6	-	A	100
3M114	14-16	8-10	-	A	100
3M162	10-12	8-10	-	A	100
3M009	18-22	4-6	RED	B	100
3M011	18-22	8-10	RED	B	100
3M029	14-16	4-6	BLUE	B	100
3M031	14-16	8-10	BLUE	B	100
3M062	10-12	8-10	YELLOW	B	100
3M0311	14-16	8-10	BLUE	C	100
3M0621	10-12	8-10	YELLOW	C	100
3M323	14-16	4-6	BLUE	D	100
3M325	14-16	8-10	BLUE	D	100
3M329	10-12	8-10	YELLOW	D	100

**RING TERMINALS**

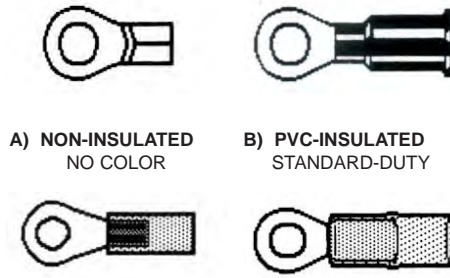

STOCK NO.	WIRE GAUGE	HOLE SIZE	INSUL. COLOR	TYPE	BOX QTY.
3M076	18-22	4-6	-	A	100
3M078	18-22	8-10	-	A	100
3M079	18-22	1/4	-	A	100
3M103	14-16	4-6	-	A	100
3M105	14-16	8-10	-	A	100
3M106	14-16	1/4	-	A	100
3M107	14-16	5/16	-	A	100
3M153	10-12	8	-	A	100
3M154	10-12	8-10	-	A	100
3M155	10-12	1/4	-	A	100
3M176	#8	1/4	-	A	100
3M178	#8	3/8	-	A	100
3M179	#8	1/2	-	A	100
3M192	#6	1/4	-	A	100
3M194	#6	3/8	-	A	100
3M195	#6	1/2	-	A	50
3M213	#4	1/4	-	A	50
3M214	#4	3/8	-	A	50
3M217	#2	1/4	-	A	25
3M218	#2	3/8	-	A	25
3M219	#2	1/2	-	A	25
3M2273	1/0	3/8	-	A	25
3M2274	1/0	1/2	-	A	25
3M2278	2/0	3/8	-	A	25
3M2279	2/0	1/2	-	A	25
3M2281	3/0	3/8	-	A	25
3M2282	3/0	1/2	-	A	25
3M2284	4/0	3/8	-	A	25
3M2285	4/0	1/2	-	A	25
3M002	18-22	4-6	RED	B	100
3M004	18-22	8-10	RED	B	100
3M005	18-22	1/4	RED	B	100
3M022	14-16	4-6	BLUE	B	100
3M023	14-16	8	BLUE	B	100
3M024	14-16	8-10	BLUE	B	100
3M025	14-16	1/4	BLUE	B	100
3M026	14-16	5/16	BLUE	B	100
3M027	14-16	3/8	BLUE	B	100
3M052	10-12	4-6	YELLOW	B	100
3M053	10-12	8	YELLOW	B	100
3M054	10-12	8-10	YELLOW	B	100
3M055	10-12	1/4	YELLOW	B	100
3M057	10-12	3/8	YELLOW	B	100
3M059	10-12	1/2	YELLOW	B	100
3M0693	#8	1/4	RED	B	50
3M0694	#8	3/8	RED	B	50
3M0695	#8	1/2	RED	B	50
3M0041	18-22	8-10	RED	C	100
3M0225	14-16	4-6	BLUE	C	100

(CONTINUED)

**HIGH TEMPERATURE RING TERMINALS**

NICKEL-PLATED STEEL. GOOD TO 900° F.

STOCK NO.	WIRE GAUGE	HOLE SIZE	INSUL. COLOR	TYPE	BOX QTY.
3M127	14-16	8-10	-	A	100
3M166	10-12	8-10	-	A	100
3M167	10-12	1/4	-	A	100

**FEMALE QUICK CONNECTORS**

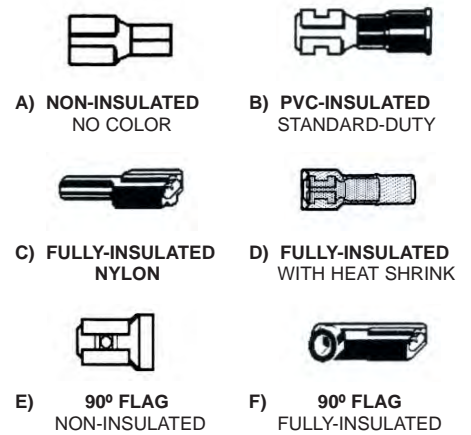

STOCK NO.	WIRE GAUGE	BLADE SIZE	INSUL. COLOR	TYPE	BOX QTY.
3M116	14-16	1/4	-	A	100
3M013	18-22	1/4	RED	B	100
3M0375	14-16	7/64	BLUE	B	100
3M036	14-16	3/16	BLUE	B	100
3M035	14-16	1/4	BLUE	B	100
3M063	10-12	1/4	YELLOW	B	100
3M015	18-22	1/4	RED	C	100
3M040	14-16	1/4	BLUE	C	100
3M066	10-12	1/4	YELLOW	C	100
3M342	14-16	1/4	BLUE	D	25
3M344	10-12	1/4	YELLOW	D	25
3M119	14-16	1/4	-	E	100
3M0405	14-16	1/4	BLUE	F	100

## WIRE TERMINALS AND ELECTRICAL ACCESSORIES

### MALE QUICK CONNECTORS

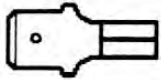

A) NON-INSULATED  
NO COLOR



B) PVC-INSULATED  
STANDARD-DUTY



C) FULLY-INSULATED  
NYLON

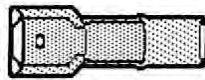

D) NYLON-INSULATED  
WITH HEAT SHRINK

STOCK NO.	WIRE GAUGE	BLADE SIZE	INSUL. COLOR	TYPE	BOX QTY.
3M115	14-16	1/4	-	A	100
3M012	18-22	1/4	RED	B	100
3M037	14-16	3/16	BLUE	B	100
3M034	14-16	1/4	BLUE	B	100
3M064	10-12	1/4	YELLOW	B	100
3M014	18-22	1/4	RED	C	100
3M041	14-16	1/4	BLUE	C	100
3M067	10-12	1/4	YELLOW	C	100
3M341	14-16	1/4	BLUE	D	25
3M343	10-12	1/4	YELLOW	D	25

### T-TAP CONNECTORS

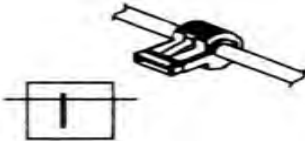

USE TO ELECTRICALLY TAP INTO A WIRE IN MID-SPAN WITHOUT CUTTING OR STRIPPING THE WIRE. CONNECTOR THEN MATES WITH A MALE TAB FOR A QUICK-CONNECT.

STOCK NO.	WIRE GAUGE	BOX QTY.
3M951X	18-22	50

### BULLET-STYLE DISCONNECTS

#### MALE & FEMALE SNAP PLUG

A) PVC-INSULATED



C) NYLON-INSULATED



STANDARD DUTY

B) NYLON-INSULATED



D) NYLON-INSULATED  
WITH HEAT SHRINK



WITH HEAT SHRINK

STOCK NO.	WIRE GAUGE	INSUL. COLOR	STYLE	BOX QTY.
3M038	14-16	BLUE	A	100
3M350	14-16	BLUE	B	100
3M039	14-16	BLUE	C	100
AV13681	14-16	BLUE	D	10

### SCOTCHLOCK CONNECTORS



STYLE A

STYLE B

STOCK NO.	WIRE GAUGE	COLOR	STYLE	BOX QTY.
3M6118	14-18	WHITE	A	50
3M6126	14-18	BLUE	B	50
3M6122	10-12	YELLOW	B	50

### CLOSED-END CONNECTORS

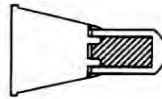

STOCK NO.	WIRE GAUGE	BOX QTY.
3M230	14-22	100
3M231	10-18	100

### WIRE NUTS

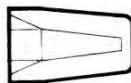

STANDARD

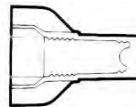

WING

STOCK NO.	SIZE	STYLE	COLOR	BOX QTY.
WN01	71B (SM.)	STD.	GRAY	100
WN02	72B	STD.	BLUE	100
WN03	73B	STD.	ORANGE	100
WN04	74B	STD.	YELLOW	100
WN05	76B	STD.	RED	100
WN07	84	WING	YELLOW	100
WN08	86	WING	RED	100
WN09	88	WING	GRAY	50
WN10	89	WING	BLUE	50

### ADDITIONAL ITEMS AVAILABLE UPON REQUEST

TWO WOULD-BE FISHERMAN RENTED A BOAT, AND ONE CAUGHT A LARGE FISH. "WE SHOULD MARK THE SPOT," HE SAID. THE OTHER MAN DREW A LARGE X IN THE BOTTOM OF THE BOAT WITH A BLACK MARKER. "THAT'S NO GOOD," SAID THE FIRST MAN. "NEXT TIME OUT WE MAY NOT GET THE SAME BOAT."

### COPPER LUGS



STOCK NO.	CABLE SIZE	STUD SIZE	BOX QTY.
AV5794	#4	3/8"	25
AV11464	#2	3/8"	10
AV11465	#1	3/8"	10
AV5796	1/0	3/8"	25
AV11466	2/0	3/8"	10
AV11467	2/0	1/2"	10

### HEAVY DUTY COPPER LUGS

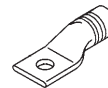

STOCK NO.	CABLE SIZE	STUD SIZE	BOX QTY.
3ML30021	#4	3/8	50
3ML30032	1/0	3/8	10
3ML30036	2/0	3/8	10
DC917835	2/0	1/2	10
3ML30041	3/0	1/2	10

### 14-16 GAUGE PIGGYBACK TERMINAL



1/4" TAB. VINYL-INSULATED. 25 PER BOX.

STOCK NO. AV12158

### WIRE TERMINAL KITS



TERMINAL ASSORTMENT WITH 175 PIECES. INSULATED AND SOLDERLESS TERMINALS. POPULAR WIRE GAUGES. PLASTIC CASE. STOCK NO. APA18K2

TERMINAL ASSORTMENT WITH 402 PIECES. PROFESSIONAL KIT IN HEAVY DUTY METAL BOX, INCLUDES CRIMPING TOOL AND CABLE TIES. STOCK NO. APSTK402

**CAN'T FIND  
SOMETHING?  
GIVE US A CALL!!**

**ELECTRICAL ACCESSORIES**

**ELECTRICAL TAPES**



**SCOTCH SUPER 33+**

7-MIL VINYL ELECTRICAL TAPE HAS FLEXIBLE PVC BACKING AND AN AGGRESSIVE PRESSURE-SENSITIVE RUBBER ADHESIVE. RESISTS WEATHER, ABRASION, ETC. FLAME RETARDANT. PRIMARY INSULATION FOR SPLICES. 3/4" x 66'.  
**STOCK NO. 3M06132**

**TEMFLEX**

7-MIL VINYL ELECTRICAL TAPE IS AN ECONOMY-GRADE, GENERAL PURPOSE TAPE. EXCELLENT MECHANICAL PROTECTION. 3/4" x 60'.  
**STOCK NO. 3M1700**

**PREMIUM 37 COLOR CODING TAPE**

ALL WEATHER 7 MIL PRESSURE SENSITIVE VINYL TAPE AVAILABLE IN DIFFERENT COLORS FOR COLOR CODING. QUICK IDENTIFICATION OF ELECTRICAL CIRCUITS, CONTAINERS AND CONDUIT SYSTEMS. PRIMARY INSULATION FOR SPLICES. 3/4 x 66'.

STOCK NO.	COLOR
BD3702	GREEN
BD3703	YELLOW
BD3704	RED
BD3705	BLUE
BD3706	WHITE
BD3708	ORANGE

**SCOTCH SUPER 88**

8.5-MIL VINYL ELECTRICAL TAPE IS THICKER AND MORE DURABLE. FLEXIBLE PVC BACKING AND PRESSURE-SENSITIVE RUBBER ADHESIVE. RESISTS WEATHER, ABRASION, ETC. FLAME RETARDANT. PRIMARY INSULATION FOR SPLICES. 3/4" x 66'.  
**STOCK NO. 3M06143**

**SCOTCH 27 GLASS CLOTH TAPE**

WOVEN GLASS CLOTH ELECTRICAL TAPE WITH THERMOSETTING ADHESIVE. HIGH MECHANICAL STRENGTH AND RESISTANT TO HIGH TEMPERATURES.  
**STOCK NO. 3M27** (1/2" x 66')  
**STOCK NO. 3M271** (3/4' x 66')

**SCOTCHFIL ELECTRICAL INSULATING PUTTY TAPE**

SYNTHETIC RUBBER COMPOUND IN TAPE FORM USED TO INSULATE LOW-VOLTAGE CONNECTIONS, BUILD-UP CABLE SPLICES AND SMOOTH IRREGULAR CONNECTIONS. 1-1/2" x 60'.  
**STOCK NO. 3M15140**

**PLYMOUTH 100 ASTM BLACK FRICTION TAPE**  
15-MIL GENERAL PURPOSE TAPE. MADE FROM QUALITY COTTON SHEETING AND MULTIPLE-COATED. SUPERIOR ADHESION EVEN ON ROUGH AND IRREGULAR SURFACES. 3/4" x 60'.  
**STOCK NO. BD860L**

**LIQUID BRUSH-ON ELECTRICAL TAPE**  
DIELECTRIC COATING SEALS OUT MOISTURE. WON'T CRACK, PEEL OR HARDEN. INSULATES, PROTECTS AND COLOR CODES. STOPS TERMINAL SCREWS FROM VIBRATING LOOSE. 4 OZ.  
**STOCK NO. APNA55**

**PLYMOUTH 122 RUBBER SPLICING TAPE**  
FAST-BONDING TAPE THAT MOLDS QUICKLY WITHOUT HEAT INTO A SOLID INSULATION MASS. SELF-AMALGAMATING. FAST VOID-FREE BUILD-UPS. FOR WATERPROOFING AND INSULATING ALL LOW VOLTAGE SPLICES. SOFT AND PLIABLE FOR ALL IRREGULAR SHAPES. USE IN COMBINATION WITH FRICTION OR VINYL-JACKETING TAPES. FOR PRIMARY INSULATION UP TO 600 VOLTS. 3/4" x 22'.  
**STOCK NO. BD822L**

**WIRE MARKING TAPES**



**.215" x 8' ROLLS - WHITE WITH NUMBERS  
FLAME-RETARDANT FILM TAPE - OIL RESISTANT**

STOCK NO.	ROLL NO.
3MSER0	#0
3MSER1	#1
3MSER2	#2
3MSER3	#3
3MSER4	#4
3MSER5	#5
3MSER6	#6
3MSER7	#7
3MSER8	#8
3MSER9	#9

**WIRE MARKING TAPE DISPENSER**



COMPACT, PLASTIC DISPENSER FILLED WITH NUMBERS 0-9. CONVENIENT ROLLS WITH NO WASTE AND PRECISE CUT-OFF. REFILLABLE.

**STOCK NO. 3M12174**

**BLACK HEAT SHRINK TUBING**



SOLD BY THE FOOT. SINGLE-WALL, FLEXIBLE POLYOLEFIN. 2:1 SHRINK RATIO. GENERAL PURPOSE INSULATION.

STOCK NO.	SIZE
SE23	1/8
SE24	3/16
SE25	1/4
SE26	3/8
SE27	1/2
SE29	3/4
SE30	1"

**BLACK HEAT SHRINK TUBING KIT**

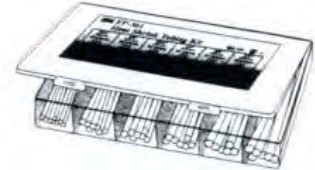

VERSATILE 102 PIECE KIT WITH SIX POPULAR DIAMETERS RANGING FROM 3/16" TO 1". SINGLE-WALL, FLEXIBLE POLYOLEFIN. 2:1 SHRINK RATIO. GENERAL PURPOSE INSULATION. 6" LENGTHS. PLASTIC CASE.

**STOCK NO. 3MFP301K**

**HEAVY-DUTY HEAT SHRINK TUBING**



**EPS-300** TUBING OFFERS INTEGRAL, ADHESIVE-LINED CONSTRUCTION. MADE FROM FLAME-RETARDANT, FLEXIBLE POLYOLEFIN WITH AN INTERNAL LAYER OF SPECIAL THERMOPLASTIC ADHESIVE AND A HEAT-SHRINKABLE OUTER WALL. WHEN HEATED IN EXCESS OF 121°C / 250°F, TUBING RAPIDLY SHRINKS TO A TIGHT FIT, FORCING MELTED ADHESIVE TO FLOW AND COVER THE SUBSTRATE. 3:1 SHRINK RATIO. PROTECTS ELECTRONIC COMPONENTS, WIRE SPLICES AND BUNDLES. SOLD BY THE FOOT.

STOCK NO.	SIZE
SE70	1/8
SE705	3/16
SE71	1/4
SE72	5/16
SE73	3/8
SE74	1/2
SE75	3/4

**WIRE LOOM**



SPLIT FLEXIBLE TUBING CAN WITHSTAND MAXIMUM TEMP. OF 345° F. BLACK. 50' LENGTH.

STOCK NO. AV14201	(1/4" ID)
STOCK NO. AV14202	(3/8" ID)
STOCK NO. AV14203	(1/2" ID)
STOCK NO. AV14204	(3/4" ID)

**RUBBER GROMMETS**



**25 PER BOX**

STOCK NO.	SIZE			
	BORE DIA.	x	GROOVE WIDTH	x GROOVE DIA.
AV4410	5/32	x	1/16	x 1/4
AV4417	1/4	x	1/16	x 7/16
AV4421	5/16	x	1/8	x 9/16
AV4426	3/8	x	1/4	x 5/8
AV4430	1/2	x	1/4	x 13/16
AV4431	5/8	x	1/8	x 7/8

### ELECTRICAL ACCESSORIES

#### AUTOMOTIVE-TYPE PRIMARY WIRE



100 FT. ROLLS

STOCK NO.	GAUGE	COLOR
AP18R	18	RED
AP18W	18	WHITE
AP18B	18	BLUE
AP18BL	18	BLACK
AP16R	16	RED
AP16W	16	WHITE
AP16B	16	BLUE
AP16BL	16	BLACK
AP14R	14	RED
AP14G	14	GREEN
AP14BL	14	BLACK
AP14B	14	BLUE
AP14W	14	WHITE
AP14Y	14	YELLOW
AP14O	14	ORANGE
AP14BR	14	BROWN
AP14P	14	PURPLE
AP12R	12	RED
AP12BL	12	BLACK
AP12W	12	WHITE
AP12Y	12	YELLOW
AP10R	10	RED
AP10W	10	WHITE
AP10B	10	BLUE
AP10BL**	10	BLACK

\*\*DENOTES 75 FT. ROLLS

#### WIRE TERMINAL PLIERS



MULTI-PURPOSE WIRING TOOL. STRIPS WIRE WITH NO DAMAGE TO CONDUCTOR. CUTS WIRE CLEAN. CRIMPS BOTH INSULATED AND NON-INSULATED WIRE. ALSO CUTS POPULAR MACHINE SCREW SIZES. PLASTIC GRIPS. 8-1/4".

STOCK NO. CHN908G



CUTS BOLTS, CRIMPS TERMINALS, STRIPS AND CUTS WIRE. ALSO CUTS POPULAR MACHINE SCREW SIZES. EXTRA-LONG FOR MORE TORQUE. CRIMPS INSULATED AND NON-INSULATED TERMINALS. MEASURING GUIDES. CUSHION-GRIP. 8-7/8".

STOCK NO. VA1001

#### HEAVY-DUTY CRIMPING AND CUTTING TOOL



DESIGNED FOR CRIMPING AND CUTTING BOTH INSULATED AND NON-INSULATED SOLDERLESS CONNECTIONS AND TERMINALS. TOOL WILL HANDLE WIRE FROM 10 TO 22 AWG. SLIM NOSE. CUSHION GRIP. 9-3/4".

STOCK NO. CHN909G

#### WIRE STRIPPER



COMPACT AND LIGHTWEIGHT STRIPPER CUTS, GAUGES, STRIPS AND LOOPS WIRE. NARROW NOSE. CLEAR GAUGE MARKINGS ON BOTH SIDES. PLASTIC-DIP HANDLES. 6" OVERALL LENGTH. STRIPS GAUGES 16, 18, 20, 22, 24, 26.

STOCK NO. VA11046

STRIPS GAUGES 10, 12, 14, 16, 18  
STOCK NO. VA11045

#### AUTOMATIC WIRE STRIPPER



STRIPS WIRE FROM 10 TO 22 AWG, UP TO A FULL 1". LEVER-ACTION. AUTO-FEATURE HOLDS JAW OPEN FOR REMOVING WIRE WITHOUT CRUSHING END. DIE CAST WITH COMFORT GRIPS. ADJUSTABLE WIRE STOP. 6-1/2" OVERALL LENGTH. STRIPS GAUGES 10, 12, 14, 16, 18, 20, 22.

STOCK NO. VA11062

#### HEAVY-DUTY WIRE CRIMPER



THIS DEVICE CRIMPS CABLE RANGE FROM 8 TO 4/0 GAUGE. USE WITH VISE OR HAMMER. FOR HEAVY-DUTY APPLICATIONS THAT HAND-HELD CRIMPERS CANNOT HANDLE. USED WITH HEAVYDUTY TERMINALS: 3ML30021, 3ML30032, ETC.

STOCK NO. SE909015

CONSULT CATALOG INDEX FOR WIRE CUTTERS

#### FUSE HOLDER

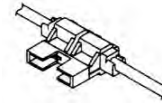

SELF-STRIPPING FUSE HOLDER SIMPLIFIES HOOK-UP AND SAVES MONEY BY ELIMINATING NEED FOR BUTT CONNECTORS OR QUICK-CONNECTS. LOCATE THE FUSE WHERE YOU WANT IT. EASY INSTALLATION. ONLY TWO CRIMPS REQUIRED. MATES WITH MOST PLUG-IN, BLADE TYPE FUSES.

STOCK NO. 3M972

#### GLASS FUSES



1/4" x 1-1/4" - 5 PER PACKAGE  
AGC DESIGNATION

STOCK NO. AMP RATING

APAGC2	2
APAGC3	3
APAGC5	5
APAGC10	10
APAGC15	15
APAGC20	20
APAGC25	25
APAGC30	30

#### SFE DESIGNATION

STOCK NO. AMP RATING

APSFE14	14
APSFE20	20
APSFE30	30

#### BLADE FUSES



5 PER PACKAGE

STOCK NO. AMP RATING

APATC3	3
APATC5	5
APATC7.5	7.5
APATC10	10
APATC15	15
APATC20	20
APATC25	25
APATC30	30

#### MINI BLADE FUSES



5 PER PACKAGE

STOCK NO. AMP RATING

APATM10	10
APATM15	15
APATM20	20
APATM25	25
APATM30	30

#### MAXI FUSE



STOCK NO. AMP RATING

DC78510	20
DC78511	30
DC78512	40

**TUBING CLAMPS, HALF CLAMPS, NYLON CLAMPS AND NYLON CABLE TIES**

**INSULATED TUBING CLAMPS WITH REMOVABLE RUBBER JACKET INSERT**



STOCK NO.	SIZE	SCREW HOLE DIAMETER
SE60	1/4	1/4
SE61	3/8	1/4
SE62	1/2	1/4
SE63	5/8	1/4
SE64	3/4	1/4
SE65	7/8	1/4
SE66	1"	1/4
SE67	1-1/8	1/4
SE68	1-1/4	1/4
SE664	1-1/2	1/4
SE668	2"	1/4

**H. D. TUBING CLAMPS**

SE601	1/4	3/8
SE611	3/8	3/8
SE621	1/2	3/8
SE631	5/8	3/8
SE641	3/4	3/8
SE651	7/8	3/8
SE661	1"	3/8
SE670	1-1/8	3/8
SE6641	1-1/4	3/8
SE691	1-3/8	3/8
SE6642	1-1/2	3/8
SE6681	2"	3/8

**INSULATED TUBING CLAMPS**



**ZINC PLATED - NEOPRENE DIPPED**

STOCK NO.	SIZE	SCREW HOLE DIAMETER
AV9381	1/4	9/32
AV9382	5/16	9/32
AV9383	3/8	9/32
AV9384	1/2	9/32
AV10601*	1/2	13/32
AV9385	5/8	9/32
AV9386	3/4	9/32
AV9387	7/8	9/32
AV9388	1"	9/32
AV10606	1-1/4"	13/32

\*HEAVY DUTY

**INSULATED HALF CLAMPS**



**ZINC PLATED - NEOPRENE DIPPED**

STOCK NO.	SIZE	SCREW HOLE DIAMETER
AV10608	3/16	7/32
AV10609	1/4	7/32
AV10610	5/16	9/32
AV10611	3/8	9/32
AV10612	7/16	9/32
AV10613	1/2	9/32
AV10614	5/8	9/32
AV10615	3/4	9/32

**NYLON CABLE CLAMPS**



STOCK NO.	SIZE	SCREW HOLE DIAMETER
SE38	1/8	3/16
SE39	3/16	3/16
SE40	1/4	3/16
SE41	3/8	3/16
SE42	1/2	3/16
SE43	5/8	3/16

**NYLON CABLE TIES**



**STANDARD**

STOCK NO.	LENGTH	TENSILE STRENGTH	COLOR	PACK QTY.
SE01	4"	18 LBS.	WHITE	100
SE011	4"	18 LBS.	WHITE	1000
SE02	5-1/2	40 LBS.	WHITE	100
SE021	5-1/2	40 LBS.	WHITE	1000
SE03	8"	50 LBS.	WHITE	100
SE031	8"	50 LBS.	WHITE	1000
SE04	11"	50 LBS.	WHITE	100
SE05	14-1/2	50 LBS.	WHITE	100
SE045	4"	18 LBS.	BLACK	100
SE046	5-1/2	40 LBS.	BLACK	100
SE047	8"	50 LBS.	BLACK	100
SE048	11"	50 LBS.	BLACK	100
SE049	14-1/2	50 LBS.	BLACK	100

**HEAVY-DUTY**

STOCK NO.	LENGTH	TENSILE STRENGTH	COLOR	PACK QTY.
SE06	14"	120 LBS.	WHITE	100
SE065	14"	120 LBS.	BLACK	100
SE10	24"	175 LBS.	WHITE	50

**ADDITIONAL ITEMS AVAILABLE UPON REQUEST**

**GIVE US A CALL FOR ALL YOUR NEEDS**



**SPECIALTY NYLON CABLE TIES**



**IDENTIFICATION TIES**

STOCK NO.	LENGTH	TENSILE STRENGTH	COLOR
SE019	7-1/2	50 LBS.	WHITE



**MOUNTING HEAD TIES - #10 SCREW HOLE**

STOCK NO.	LENGTH	TENSILE STRENGTH	COLOR
SE20	8"	50 LBS.	WHITE
SE201	8"	50LBS.	BLACK

**NYLON ADHESIVE TIE MOUNTS**



1-1/8 x 1-1/8 CENTER-MOUNTING HOLE 4-WAY ENTRY.

**STOCK NO. SE35**

**CABLE TIE INSTALLATION TOOL**



COMPACT AND STURDY. WORKS WITH UP TO 50 LB. TENSILE-RATED CABLE TIES.

**STOCK NO. SE9999**

**HOOK AND LOOP FASTENER SYSTEM**



SELF-ADHERING. NYLON HOOKS MESH WITH PLIABLE LOOPS (VELCRO) FOR FAST, SECURE CLOSURE. 1 ROLL HOOK AND 1 ROLL LOOP WITH EASY DISPENSER. EACH ROLL 4.9 YDS. BLACK. 1" WIDE.

**STOCK NO. 3MMP352627**

**ELECTRICAL AND AUTOMOTIVE ACCESSORIES**

**UNIVERSAL LEAD BATTERY END**



8 TO 2/0 GAUGE - WITH NUTS & BOLTS

STOCK NO. AP11BT

**UNIVERSAL HEAVY-DUTY LEAD BATTERY END**



1 TO 4/0 GAUGE - WITH NUTS & BOLTS

STOCK NO. APHD11X

**BATTERY TERMINALS**

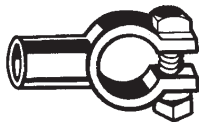

SOLDER TYPE - ALL WITH NUTS AND BOLTS

STOCK NO	TYPE	SIZE
FBT20P	(POSITIVE)	2/0
FBT20N	(NEGATIVE)	2/0
FBT30P	(POSITIVE)	3/0
FBT30N	(NEGATIVE)	3/0

**BATTERY NUTS AND BOLTS**



5/16-18 x 1-1/4 BOLTS WITH COLLARED NUTS

STOCK NO. AV3186

**SPARK PLUG WIRE TERMINALS**



7mm STRAIGHT SPARK PLUG TERMINAL

STOCK NO. AV5071

**DELUXE SNOW BRUSH AND ICE SCRAPER**



22" SNOW BRUSH/ICE SCRAPER WITH ACRYLIC HANDLE.

STOCK NO. AP19521



48" SNOW BRUSH/ICE SCRAPER WITH ACRYLIC HANDLE.

STOCK NO. AP2610XB



10" ICE SCRAPER  
STOCK NO. APW18

**OIL FILTER WRENCHES**

(2-13/16" TO 3-5/32")  
STOCK NO. AP75533



(3-1/2" TO 3-7/8")  
STOCK NO. AP75530

**ANTI-FREEZE TESTERS**



TUBE-STYLE MEASURES FREEZING POINT IN °C OR °F. CAN BE USED ON HOT OR COLD ENGINE. TESTS ALL PERMANENT (ETHYLENE GLYCOL) SOLUTIONS. LONG NOSE FOR HARD-TO-REACH FILLER NECKS.

STOCK NO. APAT902



DIAL-TYPE HAS SEPARATE SCALES FOR FREEZING AND BOILING POINTS. TESTS ALL PERMANENT (ETHYLENE GLYCOL) SOLUTIONS. CAN BE USED ON HOT OR COLD ENGINE.

STOCK NO. APAT901

**DIAL-TYPE BATTERY TESTER**



QUICKLY AND ACCURATELY TESTS 6, 12, AND 24 VOLT BATTERIES- HOT OR COLD. DETECTS OVERCHARGE. HELPS EXTEND BATTERY LIFE.

STOCK NO. APBT901

**BOOSTER CABLES**



INSULATED COPPER-STRANDED CABLES HAVE HEAVY-DUTY CLAMPS WITH COPPER-PLATED STEEL JAWS. COLOR-CODED HANDLES WITH EPOXY-COATED GRIPS, WHICH CAN LATCH ONTO TOP- AND SIDE-MOUNTED BATTERY TERMINALS. 4 GAUGE. 16' OVERALL LENGTH.

STOCK NO. AP416

**BOOSTER CLAMPS**



ONE RED, ONE BLACK

STOCK NO. GOOD14406 (400 AMP)

**BATTERY MAINTAINER / CHARGER**

**1.5 AMP AUTOMATIC BATTERY CHARGER**



AUTOMATIC CAR OR MOTORCYCLE BATTERY MAINTAINER/CHARGER. REVERSE HOOKUP PROTECTION. 1.5 AMP WITH LED INDICATOR. 6/12V.

STOCK NO. APSE1562A

**BATTERY CHARGERS**

**50/10/2 AMP CHARGER**



50 AMP ENGINE STARTER. 35 AMP RAPID CHARGE. 2 AMP TRICKLE CHARGE. FOR 12 VOLT BATTERIES. FULLY AUTOMATIC.

STOCK NO. APSE5212A

**10/40/200 AMP CHARGER**



10 AMP RATE CHARGES IN 3-5 HOURS. 40 AMP FAST-CHARGE. 200 AMP ENGINE START. FOR 12 VOLT BATTERIES. EASY-TO-READ-METER. HEAVY-DUTY CLAMPS. CONVENIENT FLEET-STYLE MOBILE CARRIER. AUTOMATIC RESETTING CIRCUIT BREAKER.

STOCK NO. APSE4020

THINKING IS THE HARDEST WORK THERE IS, WHICH IS PROBABLY THE REASON SO FEW ENGAGE IN IT.

--HENRY FORD



**ABSORBENT PRODUCTS**



**INDUSTRIAL FLOOR ABSORBENT**



THESE HIGHLY ABSORBENT CLAY GRANULES ARE FORMULATED TO MAXIMIZE ABSORPTION AND MINIMIZE DUST USING A UNIQUE "AIR SWEEP" PROCESS. THEY'RE A HARDER GRANULE, MAKING THEM IDEAL FOR HIGH-TRAFFIC AREAS. ABSORBS OIL SIMPLY AND EASILY WITH NO VISIBLE RESIDUE. SOAKS UP GREASE, OIL, WATER. KEEPS FLOORS CLEAN, SAFE AND DRY.

**STOCK NO. FD1 (50 LB. BAG.)**



**GENERAL SOCK**



TUBULAR ABSORBENT SOCK FILLED WITH RECYCLED NEWSPAPER IS YOUR BEST SOCK VALUE. CATCHES AND CONTAINS FLUIDS, LEAKS AND SPILLS, KEEPING AREAS AROUND MACHINES CLEAN, SAFE AND DRY. THE SOCK MEASURES 3" X 48".

**STOCK NO. FD7**

**OUR COURTEOUS AND  
 KNOWLEDGEABLE STAFF IS  
 READY TO TAKE CARE OF  
 YOUR ORDER!**



**UNIVERSAL BONDED PADS**



TREATED, CHEMICALLY INERT POLYPROPYLENE. "DIMPLES" BOND THE LAYERS TOGETHER TO MAKE A MORE DURABLE PAD. TOP QUALITY PADS ABSORB MOST LIQUIDS WITHOUT GUESSWORK. IDEAL FOR AREAS WHERE YOU DON'T WANT SHEDDING. USE THEM TO LINE MACHINES, TOOL BOXES AND SPILL TRAYS. PAD SIZE 15" x 19".

**STOCK NO. FD50 (6 PADS/ROLL)**  
**STOCK NO. FD5 (100 PADS/BOX)**

**FLOOR SWEEP COMPOUND**

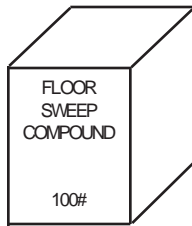

USED FOR KEEPING DUST DOWN TO A MINIMUM DURING CLEAN-UP.

**STOCK NO. FD2 100 POUNDS**

**IF YOU  
 DON'T SEE  
 SOMETHING HERE  
 YOU NEED,  
 GIVE US A CALL.**



**WE WILL  
 DO OUR  
 BEST  
 TO FIND IT  
 FOR YOU..**



**OIL ONLY PADS**



MELT-BLOWN POLYPROPYLENE. THESE HYDROPHOBIC PRODUCTS REPEL WATER WHILE ABSORBING PETROLEUM-BASED FLUIDS. IDEAL FOR INDUSTRIAL PLANT AND MARINE APPLICATIONS. HEAVY WEIGHT. PAD SIZE: 15" X 19".

**STOCK NO. FD93 (100 PADS/BOX)**

**YOUR  
 ONE-STOP  
 SOURCE  
 FOR  
 INDUSTRIAL  
 SUPPLIES**

WHAT'S THE DAILY CHARGE FOR 'FRUIT?' THE HOTEL PATRON ASKED THE MANAGER. "WE DIDN'T EAT ANY."  
 "BUT THE FRUIT WAS PLACED IN YOUR ROOM EVERY DAY. IT ISN'T OUR FAULT YOU DIDN'T TAKE ADVANTAGE OF IT."  
 "I SEE," SAID THE MAN AS HE SUBTRACTED \$150 FROM THE BILL.  
 "WHAT ARE YOU DOING?" SPUTTERED THE MANAGER.  
 "I'M SUBTRACTING 50 DOLLARS A DAY FOR YOUR KISSING MY WIFE."  
 "WHAT? I DIDN'T KISS YOUR WIFE."  
 "AH," REPLIED THE MAN, "BUT SHE WAS THERE."

### SPECIALTY TAPE

#### MASKING TAPE



GENERAL PURPOSE TAPE WITH HIGH ADHESION, EXCELLENT QUICK STICK. FOR ALL GENERAL MASKING OPERATIONS, HOLDING AND BUNDLING.

STOCK NO.	SIZE	CASE QUANTITY
T08	3/4" x 60 YD.	48
T09	1" x 60 YD.	36
T10	1-1/2" x 60 YD.	24
T11	2" x 60 YD.	24

#### STRAPPING TAPE GLASS REINFORCED

A TRANSPARENT FILAMENT-REINFORCED PRESSURE-SENSITIVE TAPE. COMBINES A SPLIT-RESISTANT POLYESTER, WITH GLASS FIBERS TO PERFORM OVER A WIDE RANGE OF APPLICATIONS, SUCH AS CLIPPING, BUNDLING, UNITIZING AND PALLETIZING. OUTSTANDING GRAB ON CORRUGATED PACKAGING.



STOCK CASE NO.	SIZE	TENSILE LBS./IN.	QUANTITY
T03	1/2" x 60 YD.	200	72
T04	3/4" x 60 YD.	200	48
T05	1" x 60 YD.	200	36

#### CARTON SEALING TAPE CLEAR-SEE THRU



A TOUGH POLYPROPYLENE FILM PRESSURE-SENSITIVE TAPE WITH AGGRESSIVE ADHESION. EASY TO DISPENSE WITH SIMPLE HAND DISPENSERS. IDEAL FOR SEE THROUGH LABELS AND CARTON CLOSURE, LIGHT AND MEDIUM PACKAGING, MENDING AND PACKAGE REPAIR.

STOCK NO.	SIZE	CASE QTY.
T02	2" x 110 YD.	36
3M371	3" x 110 YD.	24

#### TAPE DISPENSER "SCOTCH" BRAND

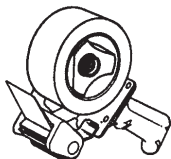

PROVIDES QUICK, EASY DISPENSING OF FILM BACK AND KRAFT SEALING TAPE DIRECTLY FROM THE ROLL. HAND HELD PORTABLE UNIT.

STOCK NO. 3MBP1 (2" DISPENSER)  
STOCK NO. 3MH183 (3" DISPENSER)

#### STATIONARY TAPE DISPENSER



THIS TABLETOP DISPENSER UNIT OFFER STABILITY AND EASY DISPENSING OF MAXIMUM 4"-WIDE TAPE ROLLS.

STOCK NO. T20

#### DUCT TAPE SILVER COLOR



GOOD ALL-PURPOSE HVAC PLASTIC COATED CLOTH DUCT TAPE. EXCELLENT TACK-ADHESION AND TENSILE STRENGTH.

STOCK NO.	SIZE	CASE QUANTITY
T13	2" x 60 YD	24
T128	4" x 60 YD	12

#### BLACK COLOR

BETTER FOR OUTDOORS, OFFERS MORE RESISTANCE AGAINST ULTRA-VIOLET RAYS. DOESN'T BREAK DOWN AS FAST.

STOCK NO.	SIZE	CASE QUANTITY
T15	2" x 60 YD.	24

#### DOUBLE FACED TAPE

STOCK NO.	SIZE
T16	2" x 25 YDS.

#### FOAM TAPE



IDEAL FOR A MULTITUDE OF GENERAL PURPOSE, INDOOR MOUNTING AND JOINING APPLICATIONS. 1/16" X 3/4" X 36YD.

STOCK NO. 3M06454

#### GAFFERS TAPE



USED IN A/V, TV, PHOTOGRAPHY, THEATRICAL AND MOTION PICTURE INDUSTRIES TO HOLD WIRING, LIGHTING, STAGE PROPS, MASKING SILK SCREEN FRAMES AND TO WATERPROOF PACKAGING.

STOCK NO.	SIZE	COLOR
T25	2" x 60YD.	BLACK
T26	2" x 60YD.	GRAY

THIS SPACE RESERVED FOR FUTURE SPECIALTY TAPE PRODUCTS

YOUR ONE STOP SOURCE FOR INDUSTRIAL SUPPLIES



**JANITORIAL EQUIPMENT & PRODUCTS**

**RECTANGULAR POLY WASTE BASKETS**

INJECTION MOLDED POLYETHYLENE MAKES THESE WASTE BASKETS AS PRACTICAL AS THEY ARE TOUGH. SEAMLESS CONSTRUCTION FOR EASY CLEANING. MOLDED IN COLOR. CAN'T CRACK, CHIP OR PEEL. COLOR: GRAY.



STOCK NO.	DIMENSIONS HGT. x WDT. x DEPTH	CAPACITY
CON2818	15" x 14-1/2" x 10-1/2"	28 QT.
CON8323	25-1/2" x 19-1/4" x 11-1/2"	23 GAL.

**STEEL ROUND WASTE BASKET**



FIRE SAFE STEEL. BUILT FOR STRENGTH AND BEAUTY. DOUBLE LOCK SEAMS. RECESSED BOTTOMS. COLOR: GRAY.

STOCK NO.	DIMENSIONS	CAPACITY
CON71N	13-1/2" DIA. x 14-1/2" HT.	26 QT.
CON72N	15-3/4" DIA. x 18" HT.	40 QT.

**SMOKER'S RECEPTACLE**



THIS SMOKER'S RECEPTACLE IS ANY EASY WAY TO KEEP UNSIGHTLY CIGARETTE LITTER NEATLY HIDDEN IN AN ATTRACTIVE, COMPACT CONTAINER. IT FEATURES AN OXYGEN RESTRICTING DESIGN TO SAFELY COLLECT CIGARETTE BUTTS AND REDUCE THE RISK OF FIRE. SIMPLY DROP IN A LIT CIGARETTE AND LET THE SELF-EXTINGUISHING DESIGN DO THE REST. SIMPLE TWO PIECE FLAME RETARDANT POLYETHYLENE

CONSTRUCTION OPENS EASILY AND INCLUDES A 1 GALLON GALVANIZED BUCKET FOR QUICK CLEANING. NON-RUSTING POLY CONSTRUCT COVERED OPENING KEEPS RAIN OUT FOR LONG-LASTING OUTDOOR USE. 11 INCH DIAMETER X 30 INCH TALL. FITS IN SNUG AREAS, PERFECT WHEN SPACE IS AT A PREMIUM. OTHER COLORS AVAILABLE.

**STOCK NO. JUS26800** (PEWTER GRAY)

**"HUSKEE" CONTAINER**



TOUGH INJECTED MOLDED CONSTRUCTION. IDEAL FOR INDUSTRIAL APPLICATIONS RANGING FROM COMMERCIAL REFUSE DISPOSAL TO FOOD HANDLING AND PROCESSING. COLOR: GRAY. AVAILABLE WITH OPTIONAL LID, OPTIONAL DOME LID, OPTIONAL DOLLY. 32 AND 55 GALLON CAPACITY.

STOCK NO.	DIMENSION	CAPACITY
CON3200	27-3/8" x 22" DIA.	32 GAL
CON5500	33" x 26-1/2" DIA.	55 GAL

CON3201	LID FOR 32 GAL CONTAINER
CON5501	LID FOR 55 GAL CONTAINER

**HUSKEE DOME TOP LID**



HEAVY DUTY STRUCTURAL PLASTIC, FOAM MOLDED DOME TOP FITS 32 GAL HUSKEE CONTAINER. FEATURES QUIET SELF-CLOSING DOORS THAT KEEP DEBRIS AND ODOR IN. WHEN USED OUTDOORS, UNIQUE DOOR DESIGN. KEEPS RAIN AND WEATHER OUT. COLOR: RED.

**STOCK NO. CON3232RED**

**STRUCTO MOBILE DOLLY**



TWIST-ON, TWIST OFF CONVERSION DOLLY FITS BOTH 32 AND 55 GAL HUSKEE CONTAINERS. MADE OF SUPREME RESIN, IT OFFERS UNBELIEVABLE MOBILITY WITH FIVE FULL-SWIVEL 3" BALL BEARING CASTERS THAT INSURE "FINGER-TOUCH" MOVEMENT WITHOUT TIPPING.

**STOCK NO. CON3255**

**DUST PANS**



**PLASTIC**



**METAL**

STOCK NO.	SIZE	DESCRIPTION
CON712	4" x 1-1/4" x 12"	MOLDED PLASTIC
CON715	2-3/4" x 12" x 13-1/2"	METAL
CON716	4-1/4" x 16" x 15"	METAL

**"HUSKEE" TILT 'N WHEEL TRASH COLLECTOR**



LARGE 50 GALLON CAPACITY. EASY-MANEUVER 8 IN. RUBBER WHEELS. DOUBLE REINFORCED PANEL FOR STRENGTH. BUILT-IN FULL WIDTH HANDLE. ATTACHED SURE-FITTING HINGED LID SMOOTH WALL FINISH. COLOR: BLACK

**STOCK NO. CON5850**

**STRUCTOLENE\* UTILITY CARTS**  
HEAVY-DUTY SEAMLESS STRUCTURAL PLASTIC



STOCK NO.	DESCRIPTION	DIMENSIONS
CON5800	CART W/ 5" NON-MARKING CASTERS	32" x 16" x 30" 200 LBS./SHELF
CON5805	LARGE CART W/ 5" NON-MARKING CASTERS	32" x 24" x 35" 200 LBS./SHELF

**JANITOR CART WITH BAG**



JANITOR CART W/25 GAL HEAVY-DUTY VINYL BAG. CART EQUIPPED W/ HANDLE, DIMENSIONS W/HANDLE FOLDED: 38-1/2" x 20-1/2" x 38-1/2"

**STOCK NO. CON174**

**TOTE TRAY**



JANI-CARRIER MADE TO FIT MOST CARTS. SIZE: 8" x 19" x 13-1/2".

**STOCK NO. CON49**

### JANITORIAL EQUIPMENT & PRODUCTS

#### FLOOR SQUEEGEES



CHOOSE CURVED OR STRAIGHT EDGE. ZINC PLATED STEEL CHANNEL RESISTS CORROSION. DUAL EDGE DESIGN WITH TOUGH STEEL SCRAPING EDGE TO LOOSEN STUBBORN DIRT. ACCEPTS REPLACEABLE BLADES.

STOCK NO.	DESCRIPTION	SIZE
WE75203	CURVED SQUEEGEE	24"
WE75207	CURVED SQUEEGEE	30"
WE75204	CURVED SQUEEGEE	36"
WE75200	STRAIGHT SQUEEGEE	18"
WE75201	STRAIGHT SQUEEGEE	24"
WE75205	STRAIGHT SQUEEGEE	30"
WE75202	STRAIGHT SQUEEGEE	36"

#### SQUEEGEE REPLACEMENT BLADES (FOR ABOVE SQUEEGEES)

STOCK NO.	BLADE SIZE
DOVS9018	18"
DOVS9024	24"
DOVS9030	30"
DOVS9036	36"

TAPERED HARDWOOD HANDLE -1-1/8" DIA.  
(FOR ALL ABOVE SQUEEGEES)

STOCK NO. WE44020 (LENGTH 5 FT.)

#### WINDOW SQUEEGEES



STOCK NO.	SIZE
CON2470	8"
CON2472	12"
CON2475	18"

#### TELESCOPIC HANDLE



STOCK NO.	SIZE
CON255008	4' TO 8'
CON255012	6' TO 12'

**LET OUR  
INVENTORY  
SERVE AS YOUR  
INVENTORY**

#### WINDSHIELD SQUEEGEE/SCRUBBER



NYLON MESH OVER SYNTHETIC SPONGE SCRUBBER, RUBBER SQUEEGEE, WITH STEEL HEAD AND HARDWOOD HANDLE.

STOCK NO.	DESCRIPTION	SIZE
AP808NY	SQUEEGEE HEAD	8"
APWH12	SQUEEGEE HANDLE	12"

#### MOSS RUBBER SQUEEGEES



DOUBLE MOSS RUBBER HAS SUPER CLEANING ACTION WITH FINE PULLING OR PUSHING OF LIQUIDS. IDEAL FOR BOTH SMOOTH OR UNEVEN SURFACES. LESS RESISTANCE COMPARED TO STANDARD SQUEEGEE RUBBER.

STOCK NO.	DESCRIPTION	SIZE
DOVMFS30	STRAIGHT RUBBER	30"

HARDWOOD HANDLE - 15/16" DIA.  
(FOR MOSS RUBBER SQUEEGEE)

STOCK NO. WE44300 (LENGTH 5 FT.)

#### "WET FLOOR" CAUTION MARKERS



CAUTION CONE - DELUXE HEAVY DUTY CONE MOLDED OF SUPER BRIGHT, UNBREAKABLE ORANGE VINYL. PERMANENTLY IMPRINTED IN BLUE WITH WEIGHTED TIP PROOF RUBBER BASE. DIMENSIONS: CONE HT. 18", BASE 11" SQ., CONE O.D. AT BASE 7-1/4", AT TOP 2-3/16.

STOCK NO. CON125

CAUTION SIGN - DOUBLE-FACED OCTAGON EASEL SIGN WITH METAL FOLDING FRAME. PERMANENT IMPRINT ON BRIGHT YELLOW DURABLE PLASTIC.

STOCK NO. CON119

#### SPONGES



STOCK NO.	SIZE
CON26768	4-1/8" x 6-1/4" x 1-5/8"
CON26769	4-3/16" x 7-9/16" x 1-11/16"

#### POLYETHYLENE SPRAY BOTTLES FOR BULK SPRAY APPLICATIONS

FEATURE A HEAVY DUTY INDUSTRIAL TRIGGER SPRAYER WITH CLOG PROOF NOZZLE AND ADJUSTABLE SPRAY PATTERN. CHEMICAL RESISTANT. ALL PARTS ARE MADE OF POLYPROPYLENE OR POLYETHYLENE WITH NO RUBBER "O"-RINGS OR GASKETS TO DRY OUT OR DETERIORATE. RUST PROOF SPRINGS AND CHECK VALVE.

TRANSLUCENT PLASTIC BOTTLES ARE REFILLABLE AND CLEAN EASILY.

#### HIGH OUTPUT



3333

STOCK NO.	DESCRIPTION
CON3333	HIGH OUTPUT PUMP SPRAYER HEAD

#### GENERAL PURPOSE



922H



916B, 922B, 932B

STOCK NO.	DESCRIPTION
CON902WW9	STD. PLASTIC SPRAY HEAD
CON916B	PLASTIC SPRAY BOTTLE (16 OZ.)
CON922B	PLASTIC SPRAY BOTTLE (22 OZ.)
CON932B	PLASTIC SPRAY BOTTLE (32 OZ.)

THE GREATEST PLEASURE I KNOW IS TO DO A GOOD ACTION BY STEALTH AND HAVE IT FOUND OUT BY ACCIDENT.

--CHARLES LAMB

**JANITORIAL EQUIPMENT & PRODUCTS**

**BATHROOM BOWL ACCESSORIES**



**POWER PLUNGER** - UNIQUE BELL SHAPED DESIGN FOR FULL POWER. IDEAL FOR TOILET BOWLS, DRAINS, TRAPS. PLUNGER DIA. 8". WOOD HANDLE 24".

**STOCK NO. CON520**

**MOP HANDLES**



REPLACE MOP HEAD IN SECONDS

STOCK NO.	DESCRIPTION	HEAD SIZE	LENGTH
WE75131	HARDWOOD	7"	54"
CON772	STEEL	7"	63"

**WIDE BAND COTTON MOP HEADS**



8 PLY. DURABLE COTTON YARN. PROVIDES GOOD ABSORBENCY. WIDE 6" CENTER BAND IS INDUSTRIAL GRADE WHITE COTTON. ADAPTABLE TO JAW-TYPE MOP HANDLES.

STOCK NO.	WEIGHT	APPROX. LGTH.	WIDTH
WE75104	24 OZ.	20"	6-1/2"

**ECONOMY COTTON MOP HEADS**



COTTON YARN. STYLE #24. EASY COTTON NARROW BAND. ADAPTABLE TO JAW-TYPE MOP HANDLES.

STOCK NO.	WEIGHT	APPROX. LGTH.	WIDTH
WE75105	16 OZ.	20"	6-1/2"

**ECONOMY MOP HANDLE**



HANDLE DIAMETER 7/8". REPLACE MOP HEAD IN SECONDS.

STOCK NO.	DESCRIPTION	HEAD SIZE	LENGTH
WE75132	HARDWOOD	5-1/2"	54"

**MOP BUCKET**

SUPER-TOUGH "STRUCTURAL FOAM" CONSTRUCTION. TWO HANDLES FOR EXTRA STABILITY. CHANNEL CONTROLLED PORING SPOUT. HANDY REAR HANDGRIP. REMOVABLE SWIVEL CASTERS.

**MOP BUCKET WITHOUT WRINGERS**



STOCK NO.	CAPACITY/DESCRIPTION
CON3353YW	35 QT. - WITH CASTERS
CON2263YW	26 QT. - WITH CASTERS

**MOP BUCKET WITH WRINGER**



STOCK NO.	CAPACITY/DESCRIPTION
CON226311YW	26 QT. -W/ 3" CASTERS & SW1
CON335311YW	35 QT. -W/ 3" CASTERS & SW1
CON33537YW	35 QT. -W/ 3" CASTERS & SW5

**STRUCTOLENE PLASTIC MOP WRINGER**



STOCK NO.	DESCRIPTION
CONSW12YW	FOR 12-32 OZ. MOPS (COMBO HORIZONTAL/DOWNWARD PRESSURE)

**PLASTIC PAILS**



12 QT. CAPACITY. HEAVY REINFORCED ROLLED TOP BODY EDGE. HEAVY DUTY GALVANIZED HANDLE ATTACHED BY MOLDED EAR.

STOCK NO.	SIZE	HEIGHT	TOP DIA.
DOV110P	12 QT.	9-1/2"	10-1/2"

**GALVANIZED PAILS**



HOT DIPPED FOR LASTING, LEAK-PROOF PERFORMANCE. DEEP CORRUGATIONS FOR EXTRA STRENGTH. BODIES ARE WIRE REINFORCED.

STOCK NO.	SIZE	HEIGHT	TOP DIA.
DOV8	8 QT.	8-1/2"	9-5/8"
DOV12	12 QT.	9-3/4"	11"
DOV14	14 QT.	10-3/4"	11-1/2"

**OUR COURTEOUS  
AND  
KNOWLEDGEABLE  
STAFF  
IS READY  
TO SERVE YOU  
PROMPTLY.**

**CALL NOW!**



**THIS SPACE  
RESERVED FOR  
FUTURE  
MAINTENANCE  
PRODUCTS**

## JANITORIAL CLEANING PRODUCTS & INDUSTRIAL PAPER PRODUCTS

### DEODORANT URINAL SCREENS



PROTECTS THE URINAL INEXPENSIVELY. SUPER FLEXIBLE VINYL SCREEN. MOLDS TO SHAPE OF ANY URINAL.

STOCK NO. JAN900

### URINAL SCREEN W/URINAL BLOCK



PROTECTS DRAIN AND DEODORIZES IN ONE STEP. PLIABLE SCREEN TRAPS DEBRIS. EFFECTIVE AND ECONOMICAL.

STOCK NO. JAN899

### URINAL BLOCKS



3 OZ NON-PARA URINAL BLOCK. PRACTICAL FOUNDATION FOR ALL DEODORIZING SYSTEMS.

STOCK NO. SC2001

### DEODORANT BOWL BLOCKS

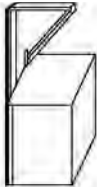

PURE PARADICHLOROBENZENE 3-1/2 OZ. BLOCK WITH LONG LASTING, PLEASING PERFUME. "TIGHT-LOCK" PLASTIC HANGER CAN'T RUST AND STAYS IN PLACE.

STOCK NO. JAN901

### ROLL TOWEL



FOLDED TOWEL QUALITY ON A ROLL WITH THESE SOFT, PLUSH, AND HIGH-QUALITY TOWELS THAT VIRTUALLY ELIMINATE WASTE.

STOCK NO.	COLOR	PLY	SHEET SIZE	ROLLS/CASE
SC2734	WHITE	1	350' x 8"	12
SC2733*	BROWN	1	350' x 8"	12
SC2719	BROWN	1	350' x 8"	12
SC2720*	BROWN	1	600' x 8"	12

\*ECONOMY

### ROLL TOWEL DISPENSER

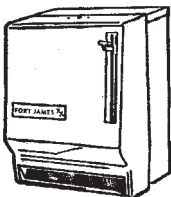

LEVER ACTION TO REDUCE WASTE. PLASTIC SHELL FOR DURABILITY.

STOCK NO. SC2571

### PAPER TOWELS



DESIGN ALLOWS FOR TOWELS TO DISPENSE ONE-AT-A-TIME, FOR LESS WASTE, MORE VALUE, AND A TIDIER WASHROOM.

STOCK NO.	COLOR	PLY	SHEET SIZE	SHEETS/CASE
SC2560	WHITE	1	12..75" x 10.25"	2,400
SC19513*	WHITE	1	9.25" x 9.5"	4,000

\*ECONOMY

### METAL TOWEL CABINET



USED WITH C-FOLD OR MULTI FOLD TOWELS

STOCK NO.	COLOR
CON990W	WHITE

### WIPING RAGS



POLO KNIT/BLEND MATERIAL. MEDIUM WEIGHT. GOOD ABSORBENCY.

STOCK NO. CHEMR150	(25 LB. BOX)
STOCK NO. CHEMR1501	(50 LB. BOX)

SWEATSHIRT/FLEECE BLEND. HEAVYWEIGHT. GOOD ABSORBENCY.

STOCK NO. CHEMR165	(25 LB. BOX)
STOCK NO. CHEMR1651	(50 LB. BOX)

COTTON/BLEND BED SHEET RAG. LIGHTWEIGHT.

STOCK NO. RAG3 (25 LB. BOX)

BATH TOWELS. SOFT. VERY ABSORBENT. HEAVYWEIGHT.

STOCK NO. RAG4 (25 LB. BOX)

FLANNEL WIPING RAGS. MEDIUM WEIGHT.

STOCK NO. RAG14 (25 LB. BOX)

### OIL-DRI SHOP TOWEL



100% COTTON. RED. PRE-WASHED. ALL PURPOSE. APPROXIMATE SIZE 15" X 15".

STOCK NO. RAG6 (25 PACK)

### 2-PLY PAPER TOWELS



30 ROLLS PER CASE. DISPENSER NOT INCLUDED.

STOCK NO. SC1220

### TOILET TISSUE



"A" "B"

"A" -STANDARD SIZE. 2-PLY.

STOCK NO. SC2645 (96/CASE)  
STOCK NO. JAN725 (PREMIUM 96/CASE)

"B" -JUMBO SIZE. 2-PLY. 4" x 1000' EACH.

STOCK NO. SC19316 (12/CASE)  
STOCK NO. SC19317 (12/CASE)

THERE ARE FEWER CHANGES WITH THE JUMBO ROLL. REDUCES PILFERAGE.

### JUMBO SIZE TOILET TISSUE DISPENSER



STOCK NO. SC2572

### STYROFOAM CUPS

1000 PER CASE.

STOCK NO.	SIZE
SC7045	8 OZ.
SC7046	10 OZ.
SC7047	12 OZ.



### STYROFOAM PLATES

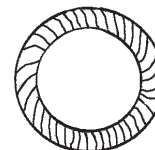

STOCK NO.	SIZE
JAN700	9"

**JANITORIAL PAPER PRODUCTS**

**HEAVY DUTY BLUE SHOP TOWELS  
(ROLLS)**



LOOKING FOR AN ABSORBENT, TOUGH, DISPOSABLE TOWEL? HERE IS THE ONE TO TRY. BLUE, 1 PLY, 11" x 10.4", 55 TOWELS/ROLL.

STOCK NO. SC75130

**HEAVY DUTY RED SHOP TOWELS**



FOR CLEANUP OF TOOLS, EQUIPMENT AND HANDS, THIS RED SHOP TOWEL, MADE OF HYDROKNIT FABRIC, WILL DO THE JOB. 1 PLY, 13.8" x 14", 50 TOWELS/BAG.

STOCK NO. SC78301

**HEAVY DUTY RED SHOP TOWELS**



FOR CLEANUP OF TOOLS EQUIPMENT AND HANDS. MADE OF HYDRO KNIT FABRIC. 10 SHEETS PER PACK, ORANGE 1 PLY.

STOCK NO. SC78101

AN ACCOUNTANT ANSWERED AN ADVERTISEMENT FOR A TOP JOB WITH A LARGE FIRM. AT THE END OF THE INTERVIEW, THE CHAIRMAN SAID, "ONE LAST QUESTION --WHAT IS THREE TIME SEVEN?"

THE ACCOUNTANT THOUGHT FOR A MOMENT AND REPLIED, "TWENTY-TWO."

OUTSIDE HE CHECKED HIMSELF ON HIS CALCULATOR AND CONCLUDED HE HAD LOST THE JOB. BUT TWO WEEKS LATER HE WAS OFFERED THE POST. HE ASKED THE CHAIRMAN WHY HE HAD BEEN APPOINTED WHEN HE HAD GIVEN THE WRONG ANSWER.

"YOU WERE THE CLOSEST." THE CHAIRMAN REPLIED.

**RAGS IN A BOX**



WORKS LIKE CLOTH. CLEAN. WHITE. REMARKABLY LINT FREE. STRONG WHEN WET. EASY DISPENSING CARRY ALONG BOX. 200 RAGS PER BOX.

STOCK NO. SC75266

**SCOTT BRAND WYPALL WIPERS**

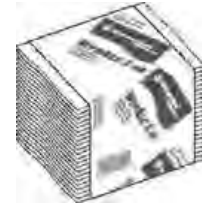

MEDIUM-DUTY, ALL-PURPOSE WIPES OFFER STRENGTH AND SOFTNESS. ABSORBS OILS, LIQUIDS AND GREASE. 1000 COUNT PER CASE. WHITE.

STOCK NO. SC5701

**BLUE WINDSHIELD TOWELS**



USED FOR CLEANING SMOOTH SURFACE SMUDGES AND STREAKS. BLUE, 2-PLY, 140 SHEETS/PACK. 16 PACK/CASE.

STOCK NO. SC33006

**KREW 300 WIPERS**



FOR GENERAL CLEANUP OF TOOLS, PARTS, OR EQUIPMENT. TAN, 4 PLY.

STOCK NO. SC33900

**KREW 600 SHOP TOWELS**



FOR CRITICAL TASKS SUCH AS REBUILDING TRANSMISSION OR FINAL PREP WIPE. BLUE 1 PLY.

STOCK NO. SC33944

**OUR  
COURTEOUS  
AND  
KNOWLEDGEABLE  
STAFF  
IS  
READY  
TO  
TAKE  
CARE  
OF  
YOUR  
ORDER.  
CALL NOW!**



ANGER IS A WIND WHICH BLOWS OUT THE LAMP OF THE MIND.

--ROBERT G. INGERSOLL

**GARDEN HOSE, SPECIALTY HOSE & ACCESSORIES**

**PVC DISCHARGE HOSE**



DESIGNED AS STANDARD DUTY HOSE FOR WATER DISCHARGE. STRONG, ECONOMICAL, LIGHTWEIGHT HOSE WHICH ROLLS UP FLAT FOR EASY STORAGE.

STOCK NO.	SIZE
SI75411501	1-1/2"
SI75412001	2"

SUCTION HOSE AVAILABLE PER REQUEST, GIVE OUR SERVICE COUNTER A CALL

**METAL GARDEN HOSE HANGER**



PROVIDES EASY STORAGE OF HOSES. HOLDS UP TO 100' OF HOSE. KEYHOLE DESIGN FOR EASY INSTALLATION. DURABLE AND RUST RESISTANT CONSTRUCTION. 5-7/8" DEEP. 10-1/4" ARC.

STOCK NO. MAG8115

**REINFORCED GARDEN HOSE**



KNITTED-NYLON-REINFORCED. TOUGH, WEATHER-RESISTANT VINYL COVER. EXCELLENT HANDLING, EVEN IN COLD WEATHER. SOLID BRASS FULL FLOW COUPLINGS.

STOCK NO.	SIZE
GHFR5850	5/8" x 50'
GHFR58100	5/8" x 100'

A WOMAN AND HER HUSBAND INTERRUPTED THEIR VACATION TO GO TO A DENTIST. "I WANT A TOOTH PULLED, AND I DON'T WANT NOVACAIN BECAUSE I'M IN A BIG HURRY," THE WOMAN SAID. "JUST EXTRACT THE TOOTH AS QUICKLY AS POSSIBLE, AND WE'LL BE ON OUR WAY." THE DENTIST WAS QUITE IMPRESSED. "YOU'RE CERTAINLY A COURAGEOUS WOMAN," HE SAID. "WHICH TOOTH IS IT?" THE WOMAN TURNED TO HER HUSBAND AND SAID, "SHOW HIM YOUR TOOTH, DEAR."

**WEATHER BEATER GARDEN HOSE**  
FEATURES FLEX-GARD HOSE PROTECTOR.



HIGH BURST STRENGTH. HEAVY-DUTY OCTAGONAL BRASS COUPLING. RADIAL BELTED, DOUBLE REINFORCED WALLS.

STOCK NO.	SIZE
GHWB5850	5/8" x 50'
GHWB5875	5/8" x 75'
GHWB58100	5/8" x 100'

**"FOREVER" RUBBER/VINYL GARDEN HOSE**



FEATURES FLEX-GARD COLLAR. SCUFF-RESISTANT RUBBER/VINYL JACKET. HIGH BURST STRENGTH. DOUBLE NYLON REINFORCED. HEAVY-DUTY CRUSH-PROOF SOLID BRASS COUPLINGS.

STOCK NO.	SIZE
GHFXN5850	5/8" x 50'
GHFXN58100	5/8" x 100'
GHFXN3450	3/4" x 50'

**PROFESSIONAL GRADE GARDEN HOSE**



GUARD-N-GRIP COUPLING SYSTEM (THE BEST). 6-PLY CONSTRUCTION FOR SUPERIOR STRENGTH. DURABLE YET FLEXIBLE. SCUFF-RESISTANT OUTER JACKET.

STOCK NO.	SIZE
GHPG5860	5/8" x 60'
GHPG5890	5/8" x 90'

**HOT WATER PREMIUM RUBBER GARDEN HOSE**



IDEAL FOR COMMERCIAL USE. WITHSTANDS HOT WATER UP TO 180°F. HIGH BURST STRENGTH. HEAVY-DUTY BRASS COUPLING.

STOCK NO.	SIZE
GHPH5850	5/8" x 50'
GHPH5875	5/8" x 75'
GHPH3450	3/4" x 50'

**HEAVY-DUTY GARDEN HOSE NOZZLE**



INSULATED, ALL-WEATHER NOZZLE. MOLDED GRIP AND INDUSTRIAL-STRENGTH LEVER. HOLD-OPEN CLIP. THREADED FRONT.

STOCK NO. SIGHN572

5-1/2" ZINC ALLOY SPRAY NOZZLE WITH AN INSULATED HANDLE AND MOLDED GRIP. HOLD-OPEN CLIP.



STOCK NO. FV035

**6-WAY ADJUSTABLE NOZZLE**



5-1/2" ZINC ALLOY NOZZLE WITH SIX POSITION ADJUSTABLE SPRAY HEAD. INSULATED HANDLE AND MOLDED GRIP

STOCK NO. FV036

**BRASS INDUSTRIAL HOSE NOZZLE**

4-1/4" SOLID BRASS TWIST NOZZLE



STOCK NO. FV037

HI-PRESSURE. ONE-PIECE, SOLID BRASS CONSTRUCTION. IDEAL FOR CLEANING AUTOS, BOATS, SIDEWALKS, DRIVEWAYS. MUST BE SHUT OFF AT VALVE, NOT AT NOZZLE.



STOCK NO. FV038



**Little GIANT**  
 Pump Company

**INDUSTRIAL PUMPS**

**Little GIANT**  
 Pump Company

**SMALL SUBMERSIBLE PUMPS**

ALL UNITS FEATURE CAST ALUMINUM HOUSING WITH PROTECTIVE EPOXY COATING, 1/4" MNPT DISCHARGE, AND POWER CORD WITH 3-PRONG MOLDED PLUG.



3' POWER CORD. POLYPROPYLENE FRONT AND IMPELLER. POLYETHYLENE SCREEN. 3.0 PSI. 170 GPH @ 1', 140 GPH @ 3', 100 GPH @ 5'. SHUTOFF @ 7'.

STOCK NO. LG500000

6' POWER CORD. UL LISTED. POLYPROPYLENE FRONT AND IMPELLER. POLYPROPYLENE SCREEN. 3.2 PSI. 205 GPH @ 1', 168 GPH @ 3', 120 GPH @ 5'. SHUTOFF @ 7.4'.

STOCK NO. LG501003



6' POWER CORD. UL LISTED. SMOOTH, HOODED INTAKE WITH POLYPROPYLENE SCREEN. THERMALLY PROTECTED. 5.1 PSI. 300 GPH @ 1', 255 GPH @ 3', 205 @ 5', 70 GPH @ 10'. SHUTOFF @ 11.8'.

STOCK NO. LG502103



FOR MILD ACID, ALKALI AND HARD WATER APPLICATIONS. CORROSION-RESISTANT NYLON HOUSING. THERMALLY PROTECTED. 6' POWER CORD. 4.4 PSI. 210 GPH @ 1', 180 GPH @ 3', 150 GPH @ 5'. SHUTOFF @ 10.2'.

STOCK NO. LG526003

SAME AS ABOVE MODEL, BUT LARGER MOTOR. 5.3 PSI. 325 GPH @ 1', 300 GPH @ 3', 270 GPH @ 5', 130 @ 10'. SHUTOFF @ 12.3'. 6' POWER CORD.

STOCK NO. LG527003



6' POWER CORD. UL LISTED. POLYPROPYLENE SCREEN, 3/4" FNPT INTAKE, AND 1/2" MNPT DISCHARGE. THERMALLY PROTECTED. HEAVY-DUTY MOTOR. 10.6 PSI. 810 GPH @ 1', 790 GPH @ 3', 745

GPH @ 5', 613 GPH @ 10', 415 GPH @ 15', 173 GPH @ 20', 80 GPH @ 22'. SHUTOFF @ 24.5'.

STOCK NO. LG504203

**SMALL SUBMERSIBLE PUMPS (CONTINUED)**



6' POWER CORD. UL LISTED. NYLON HOUSING. IMPEDANCE PROTECTED. 2.0 PSI. 120 GPH @ 1', 70 GPH @ 3'. SHUTOFF @ 4.6'.

STOCK NO. LG523003

**SUBMERSIBLE PARTS WASHER PUMP**



FOR USE WITH STODDARD SOLVENT AND DEODORIZED KEROSENE SUBMERGED PARTS WASHER APPLICATIONS ONLY. SEALED UNIT HAS DOUBLE-LIP AND NYLON HEAD. CAST ALUMINUM HOUSING. 1/4" MNPT DISCHARGE. 6' POWER CORD. THERMALLY PROTECTED. 3.2 PSI. 205 GPH @ 1', 168 GPH @ 3', 120 GPH @ 5'. SHUTOFF @ 7.4'.

STOCK NO. LG501020

**DUAL PURPOSE PUMP**

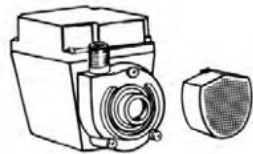

CAN BE SUBMERSED OR USED IN-LINE. UL LISTED. CAST ALUMINUM HOUSING WITH PROTECTIVE EPOXY COATING. THREADED INTAKE AND DISCHARGE. NYLON PUMPING

HEAD AND IMPELLER. THERMAL OVERLOAD PROTECTION. 6' POWER CORD WITH 3-PRONG MOLDED PLUG. 7.5 PSI. 500 GPH @ 1', 435 GPH @ 3', 337 GPH @ 5', 210 GPH @ 10', 65 GPH @ 15'. SHUTOFF @ 17.3'.

STOCK NO. LG503103

**NON-SUBMERSIBLE UTILITY PUMPS**

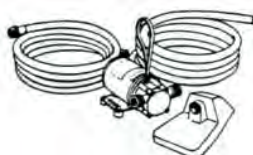

POLYPROPYLENE PUMPING HEAD, POLYACETAL CAM AND STAINLESS STEEL SHAFT. 3/8" FNPT AND 3/4" GARDEN HOSE INTAKE AND DISCHARGE. TWO 10' SECTIONS OF GARDEN HOSE,

WITH WATER EATER ACCESSORY. SELF-PRIMING PUMP IS THERMALLY PROTECTED. UL LISTED. 6' POWER CORD. 275 GPH @ 1', 225 GPH @ 10', 165 GPH @ 20'. INTERMITTENT USE.

STOCK NO. LG555150

Little Giant



VERSATILE UTILITY PUMPS REMOVE WATER TO WITHIN 1/8" OF THE SURFACE. CAST ALUMINUM HOUSING WITH PROTECTIVE EPOXY COATING.



BOTTOM SUMP-TYPE PICK UP WITH REMOVABLE PLASTIC SCREEN. 1" FNPT DISCHARGE WITH GARDEN HOSE ADAPTER. UL LISTED. 10' POWER CORD. 11.4 PSI. 1200 GPH @ 1', 1100 GPH @ 5', 1000 GPH @ 10', 520 GPH @ 20'. SHUTOFF @ 26.3'.

STOCK NO. LG505000

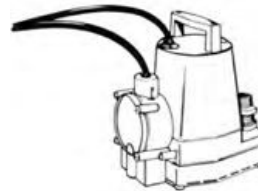

AUTOMATIC/MANUAL VERSION OF PUMP FEATURED ABOVE. THERMALLY PROTECTED. "ON" LEVEL: 6"-9". "OFF" LEVEL: 1"-4".

STOCK NO. LG505300

**BIG JOHN® SUMP PUMPS**

FOR EXTENDED OR CONTINUOUS USE IN MOVING LARGE VOLUMES OF WATER. PRESSURE-ACTIVATED "ON" - "OFF" SWITCH ENGAGES IN 7" - 10" OF WATER AND DISENGAGES IN 2" - 5". IDEAL FOR USE IN EXCAVATION, BASEMENT, UNDERGROUND PASSAGEWAY, CONSTRUCTION AND FIRE CLEAN-UP. ALL UNITS FEATURE CAST IRON HOUSING, EPOXY COATING, POLYPROPYLENE BASE, THERMAL OVERLOAD PROTECTION, SCREENED INTAKE.



MANUAL VERSION IDEAL FOR CONTINUOUS-DUTY PERFORMANCE. HANDLES LIQUIDS AND SOLID WASTE MATERIALS UP TO 1/2" DIAMETER. 1-1/2" FNPT DISCHARGE. UL LISTED. 10' POWER CORD. 8.7 PSI. 3000 GPH @ 5', 2500 GPH @ 10', 1600 GPH @ 15'. 1/3 HP.

STOCK NO. LG506710



AUTOMATIC VERSION OF PUMP FEATURED ABOVE. INCLUDES INTEGRAL, SNAP-ACTION, MECHANICAL FLOAT SWITCH FOR AUTOMATIC OPERATION. "ON" - "OFF" LEVELS 7" - 10" AND 2" - 5". 1/3 HP.

STOCK NO. LG506700

"BIG JOHN" SUMP PUMPS  
 CONTINUED NEXT PAGE

**Little GIANT**  
Pump Company

**INDUSTRIAL PUMPS**

**Little GIANT**  
Pump Company

**BIG JOHN® SUMP PUMPS**  
(CONTINUED)



UL LISTED AUTO-MATIC MODEL. 3/10 HP. MOTOR WITH SLEEVE BEARINGS. DIAPHRAGM OPERATED AUTOMATIC SWITCH. 1-1/2" FNPT DISCHARGE WITH A 1-1/4" FNPT ADAPTER. 8' POWER CORD. 7.8

PSI. 2750 GPH @ 5', 1750 GPH @ 10', 750 GPH @ 15'. SHUTOFF @ 18.0'.

STOCK NO. LG506158

**PUMP SWITCH REPAIR KIT FOR 506158 (ABOVE)**



PRESSURE SWITCH BRACKET, SCREW, DIAPHRAGM AND O-RING.

STOCK NO. LG599320

**DIAPHRAGM SWITCH**



STOCK NO. LG599008

**IF YOU  
NEED IT  
AND  
WE DON'T  
HAVE IT,  
IT'S OUR JOB  
TO GET  
IT FOR YOU!**



**DE-WATERING AND EFFLUENT PUMPS**

**COMPLETELY SUBMERSIBLE. CAST IRON PUMP HOUSINGS WITH PROTECTIVE EPOXY COATING. LUBRICATED MOTOR HOUSINGS. VORTEX IMPELLER. THERMAL OVERLOAD PROTECTION. MERCURY FLOAT SWITCH.**

UL LISTED MANUAL



MODEL WITH 15' POWER CORD. HANDLES LIQUIDS AND SOLID WASTE MATERIALS UP TO 3/4" DIAMETER. 4/10 HP. MOTOR. 1-1/2" FNPT DISCHARGE. GLASS-FILLED NYLON COVER AND ABS BASE. 10.0 PSI. 57 GPM @ 5', 53 GPM @ 10', 40 GPM @ 15'. SHUTOFF @ 23'.

STOCK NO. LG509200



UL LISTED AUTOMATIC MODEL WITH 15' POWER CORD. FLOAT SWITCH. STATS SAME AS MODEL FEATURED ABOVE.

STOCK NO. LG509300



UL LISTED MANUAL MODEL WITH 15' POWER CORD. HANDLES LIQUIDS AND SOLID WASTE MATERIALS UP TO 3/4" DIAMETER. 1/2 HP. MOTOR. 1-1/2" FNPT DISCHARGE. CAST IRON VOLUTE. VORTEX NYLON IMPELLER. ABS BASE. 15' POWER CORD. 11.2 PSI. 80 GPM @ 5', 67

GPM @ 10', 33 GPM @ 20'. SHUTOFF @ 26'.

STOCK NO. LG511200



**SEWAGE PUMPS**

**COMPLETELY SUBMERSIBLE. CAST IRON PUMP HOUSINGS WITH PROTECTIVE EPOXY COATING. LUBRICATED MOTOR HOUSINGS. VORTEX IMPELLER. THERMAL OVERLOAD PROTECTION. MERCURY FLOAT SWITCH.**



UL LISTED AUTOMATIC MODEL WITH 15' POWER CORD. HANDLES LIQUIDS AND SOLID WASTE MATERIALS UP TO 2" DIAMETER. 4/10 HP. MOTOR. 2" FNPT DISCHARGE. GLASS-FILLED NYLON COVER. MERCURY FLOAT SWITCH. 7.8 PSI. 80 GPM @ 5', 50 GPM @ 10'. SHUTOFF @ 18'.

STOCK NO. LG509500

ADDITIONAL PUMPS  
AVAILABLE UPON REQUEST

**CALL IN YOUR  
ORDER AND REFER  
TO OUR CATALOG  
STOCK NUMBERS FOR  
USER-FRIENDLY  
SERVICE**

# HUDSON®

## PROFESSIONAL SPRAYERS

# HUDSON®

### CONSTRUCTO SPRAYERS BETTER QUALITY

BETTER QUALITY SPRAYERS WITH PROVEN DURABILITY - A FINE VALUE. YOUR CHOICE OF ENDURALL EPOXY-COATED GALVANIZED STEEL OR HIGH-DENSITY POLYETHYLENE.



#### EPOXY-COATED GALVANIZED STEEL

STOCK NO.	ACTUAL CAPACITY GALLONS
HDH91063	2.5
HDH91064	3.5



#### HIGH-DENSITY POLYETHYLENE

HDH90183	3
----------	---

**WE STOCK MANY POPULAR REPLACEMENT PARTS FOR HUDSON SPRAYERS. CALL FOR AVAILABILITY**

### INDUSTRO SPRAYERS BEST QUALITY



OUR BEST GENERAL PURPOSE SPRAYERS PROVIDE LONG SERVICE UNDER TOUGH CONDITIONS. YOUR CHOICE OF STAINLESS STEEL, EPOXY-COATED GALVANIZED STEEL OR HEAVY-DUTY POLYETHYLENE.

#### STAINLESS STEEL

STOCK NO.	ACTUAL CAPACITY GALLONS
HDH91703	2.5
HDH91704	3.5

#### EPOXY-COATED GALVANIZED STEEL

-	2
-	3

### SUPER SPRAYER HIGH PERFORMANCE QUALITY



A HIGH PERFORMANCE SPRAYER WITH ENOUGH MUSCLE FOR ANY JOB! COMES IN PROFESSIONAL GRADE HIGH DENSITY POLYETHYLENE. INCLUDES HUDSON'S MOST CHEMICAL RESISTANT HOSE

STOCK NO.	ACTUAL CAPACITY GALLONS
HDH90162	2

QUESTION: WHAT'S THE DIFFERENCE BETWEEN A HUNTER AND A FISHERMAN?  
ANSWER: A HUNTER LIES IN WAIT WHILE A FISHERMAN WAITS AND LIES.

### SPRAY THICK™ CEMENT CURING COMPOUND SPRAYERS

DESIGNED TO APPLY CEMENT CURING COMPOUNDS



#### EPOXY-COATED GALVANIZED STEEL

STOCK NO.	ACTUAL CAPACITY GALLONS
HDH91004CC	3.5

#### HIGH-DENSITY POLYETHYLENE

HDH91184CC	3.5
------------	-----

### SPRAYER MAINTENANCE KIT



FOR CONSTRUCTO POLY SPRAYERS  
STOCK NO. HDH91203

FOR INDUSTRO CURING COMPOUND STEEL SPRAYERS WITH FUNNEL  
STOCK NO. HDH91201

FOR INDUSTRO CURING COMPOUND STEEL SPRAYERS WITHOUT FUNNEL  
STOCK NO. HDH91210V  
STOCK NO. HSH91215

**WE STOCK MANY POPULAR REPLACEMENT PARTS FOR HUDSON SPRAYERS. CALL FOR AVAILABILITY.**

## TRASH BAGS, POLYETHYLENE FILM, DROP CLOTHS, TARPS AND STRETCH WRAP

### TALL KITCHEN TRASH BAGS



STOCK NO.	DESCRIPTION	QUANTITY PER BOX
VQHK13130W	13 GAL.	130

### HUSKY DRUM LINER TRASH BAGS



STOCK NO.	DESCRIPTION	QUANTITY PER BOX
VQHK33060B	33 GAL	60
VQPA8055HD	55 GAL.	80

### HUSKY CONTRACTOR CLEAN-UP BAGS



FOR HEAVY DUTY CLEAN UP AFTER THE TOUGH JOBS ARE DONE. GREAT FOR CARPENTRY, ELECTRICAL, LANDSCAPE, DRYWALL, PLUMBING AND PAINTING. 3 MIL.

STOCK NO.	DESCRIPTION	QUANTITY PER BOX
VQPA3007	42 GAL.	32

### PLASTIC DROPCLOTHS



STOCK NO.	DESCRIPTION
AFS28040	9' x 12'

### CLEAR POLYETHYLENE FILM



STOCK NO.	MIL	DESCRIPTION
VQ312	3 MIL	12' x 100'
VQ403	4 MIL	3' x 100'
VQ404	4 MIL	4' x 100'
VQ406	4 MIL	6' x 100'
VQ408	4 MIL	8' x 100'
VQ410	4 MIL	10' x 100'
VQ412	4 MIL	12' x 100'
VQ414	4 MIL	14' x 100'
VQ416	4 MIL	16' x 100'
VQ420	4 MIL	20' x 100'
VQ424	4 MIL	24' x 100'
VQ432	4 MIL	32' x 100'
VQ440	4 MIL	40' x 100'
VQ608	6 MIL	8' x 100'
VQ610	6 MIL	10' x 100'
VQ612	6 MIL	12' x 100'
VQ614	6 MIL	14' x 100'
VQ616	6 MIL	16' x 100'
VQ620	6 MIL	20' x 100'
VQ624	6 MIL	24' x 100'
VQ632	6 MIL	32' x 100'
VQ640	6 MIL	40' x 100'

### BLACK POLYETHYLENE FILM



STOCK NO.	MIL	DESCRIPTION
VQ406B	4 MIL	6' x 100'
VQ410B	4 MIL	10' x 100'
VQ420B	4 MIL	20' x 100'

### STRETCH WRAP WITH HANDLES



STRETCH WRAP ON DISPOSABLE EXTENDED CORE HANDLES.

STOCK NO.	SIZE	GAUGE
FD414	20" W x 1000FT.	80 GA

### POLYTUF TARPS



DURABLE, ALL-PURPOSE UTILITY COVER THAT'S LIGHTWEIGHT, EASY TO HANDLE, AND TOUGH.

- RUGGED WOVEN POLYETHYLENE FABRIC COATED SIDES WITH POLYETHYLENE FILM.
- GROMMETTED EVERY THREE FEET WITH ROPE IN HEM ALL AROUND FOR STRENGTH.
- WATER & MILDEW-PROOF. ACID, ALKALI, AND SALT RESISTANT. CRACK RESISTANT TO 20°F.

STOCK NO.	DESCRIPTION
PT01	6' x 8'
PT02	8' x 10'
PT03	9' x 12'
PT035	12' x 14'
PT075	12' x 20'
PT08	12' x 22'
PT04	14' x 18'
PT05	16' x 20'
PT06	18' x 24'
PT07	20' x 20'
PT085	20' x 30'
PT09	20' x 40'
PT086	30' x 40'
PT087	30' x 50'
PT088	30' x 60'
PT14	40' x 60'
PT16	60' x 60'

### STRETCH WRAP



EXTRA-STRONG, FILM HOLDS UP AGAINST PUNCTURING. TIGHTLY SECURES AND PROTECTS PALLET LOADS EFFICIENTLY AND ECONOMICALLY. EASY TO APPLY.

STOCK NO.	SIZE	GAUGE
FD25	3" W x 1000FT.	80 GA.
FD3	15" W x 1500 FT.	80 GA.
FD31	15" W x 1500FT.	90 GA.
FD4	18" W x 1500 FT.	80 GA.
FD415	20" W x 5000FT.	80 GA.

### STRETCH WRAPPING HANDLE



PRECISE TENSION CONTROL FOR MAXIMUM STRETCH AND ECONOMY. CAST-FLAT ZINC BASE GIVES SMOOTH FILM STRETCH. FOAM HANDLE DESIGNED FOR COMFORT AND IS PRESS FIT TO BASE. BOTTOM CORE HOLDER DELIVERS SMOOTH FILM STRETCH. TOP TENSION CONTROL

ASSEMBLY KEEPS STRETCH CONSTANT AND OFFERS A RANGE OF ADJUSTMENTS. 3.5 LBS.

STOCK NO. FD45



SHOP-VAC



ACCESSORIES

DISPOSABLE FILTER BAGS



FOR FINE DUST AND PARTICLES. EASY TO INSTALL AND USE. HIGH EFFICIENCY FOR IMPROVED AIR QUALITY. 3 PER PACK.

5, 6, & 8 GALLON  
**STOCK NO. SV90661**

10, 12 & 14 GALLON  
**STOCK NO. SV90662**

16, 20, & 25 GALLON  
**STOCK NO. SV90663**

1-1/4" CLEANING ACCESSORY KIT



INCLUDES ROUND BRUSH, GULPER NOZZLE AND CREVICE TOOL.

**STOCK NO. SV906438**

CREVICE TOOL



FOR HARD-TO-REACH PLACES SUCH AS RADIATORS AND VEHICLE INTERIORS.

**STOCK NO. SV906164** (FITS 1-1/4" HOSE)  
**STOCK NO. SV90678** (FITS 2-1/2" HOSE)

14" FLOOR NOZZLE



FOR WIDE AREA BULK DRY PICK-UP. FOR 2-1/2" HOSE.

**STOCK NO. SV90677**

2-1/2" HOSE COUPLING



**STOCK NO. SV90686**

INDUSTRIAL SERIES  
 WET/DRY VACUUMS

INDUSTRIAL SERIES WET/DRY VACUUMS FEATURE POWERFUL MOTORS WITH QUIET OPERATIONS. EACH HAVE RUGGED TANKS MADE OF RUST-PROOF PLASTIC, ANTI-TIP PUSH-IN CASTER FEET, AN AUTOMATIC SHUT-OFF VALVE AND CONVENIENT POWER CORD STORAGE.



6 GALLON

3 HP. INCLUDES 8' x 1-1/4" HOSE, TWO 1-1/4" EXTENSION WANDS, 10" COMBINATION NOZZLE WITH SQUEEGEE. CREVICE TOOL, GULPER NOZZLE, CARTRIDGE FILTER, DRYWALL FILTER BAG

**STOCK NO. SV9620610**



12 GALLON

5 HP. INCLUDES 6' x 2-1/2" HOSE W/LOCKING ENDS, (2) 2-1/2" EXTENSION WANDS, 8" UTILITY NOZZLE, 14" FLOOR NOZZLE WITH SQUEEGEE INSERT, CREVICE TOOL, TOOL HOLDER.

**STOCK NO. SV9254110**

16 GALLON

6.25 HP. INCLUDES 6' x 2-1/2" HOSE W/LOCKING ENDS, (2) 2-1/2" EXTENSION WANDS, 8" UTILITY NOZZLE, 14" FLOOR NOZZLE WITH SQUEEGEE INSERT, CREVICE TOOL, TOOL HOLDER.

**STOCK NO. SV9254210**

18 GALLON

6.5 HP. INCLUDES 6' x 2-1/2" HOSE W/LOCKING ENDS, (2) 2-1/2" EXTENSION WANDS, 8" UTILITY NOZZLE, 14" FLOOR NOZZLE WITH SQUEEGEE INSERT, CREVICE TOOL, TOOL HOLDER.

**STOCK NO. SV9254310**

22 GALLON

6.5 HP. INCLUDES 6' x 2-1/2" HOSE W/LOCKING ENDS, (2) 2-1/2" EXTENSION WANDS, 8" UTILITY NOZZLE, 14" FLOOR NOZZLE WITH SQUEEGEE INSERT, CREVICE TOOL, TOOL HOLDER.

**STOCK NO. SV9254410**

ACCESSORIES

CARTRIDGE FILTER



**STOCK NO. SV90304**

FOAM FILTER



**STOCK NO. SV905851**

REUSABLE FILTER



**STOCK NO. SV901074** (3 PER PACK)

VACUUM HOSE



HOSE IS 2-1/2" x 10'

**STOCK NO. SV901348**

1-1/4" EXTENSION WAND



HELPFUL AT GETTING TO THOSE HARD TO REACH PLACES WITH ITS 27" REACH.

**STOCK NO. SV906149**

2-1/2" EXTENSION WAND



HELPFUL AT GETTING TO THOSE HARD TO REACH PLACES WITH ITS 40" REACH.

**STOCK NO. SV90684** (2 PACK)



**MAINTENANCE BRUSHES/ACCESSORIES**



**UPRIGHT BROOMS**



CORN WAREHOUSE BROOM. FOR SMOOTH CEMENT OR WOOD FLOORS IN FACTORY OR WAREHOUSE. STEEL HANDLE.

STOCK NO. LIB302



PALMYRA BROOM. LIGHT, EASY SWEEPING. FLARED FIBER. METAL CAP SUPPORT. TRIM 10", FLARED FACE 11-1/2". HANDLE 40" LONG.

STOCK NO. WE44007

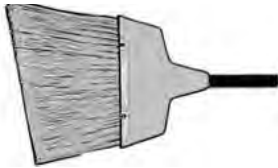

ANGLED FLOOR BROOM. PLASTIC FILL. FLAGGED TIPS AND STEEL HANDLE ATTACHED. DESIGNED FOR SMOOTH FLOORS. ANGLED TRIM FOR HARD-TO-REACH-PLACES.

STOCK NO. LIB997

**BENCH DUSTER**



HEAVY-DUTY TRI-COLOR TAMPICO FILL. OVERALL LENGTH 13-1/2". FINISHED HARDWOOD BLOCK. FOR GENERAL SHOP USE.

STOCK NO. WE44004

**WHISK BROOMS**

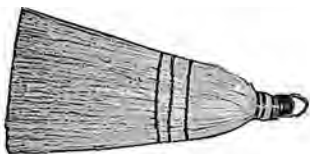

CORN AND FIBER FILL BROOM. LENGTH 10".

STOCK NO. WE44266



PALMETTO FIBER. LENGTH 7".

STOCK NO. WE44099

**COTTON MOP HEADS**

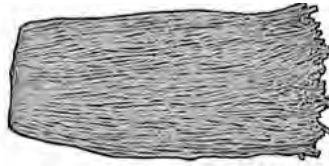

INDUSTRIAL GRADE 8 PLY WIDE BAND COTTON MOP HEADS. 24 OZ. EACH MOP HEAD IS PACKED IN A POLY-BAG.

STOCK NO. WE75104



QUICK-CHANGE HEAVY-DUTY MOP HANDLE. SCREW TYPE. HARDWOOD STYLE. 7" HEAD SIZE. 54" LONG.

STOCK NO. WE75131

STEEL STYLE. 7" HEAD SIZE. 63" LONG.

STOCK NO. CON772

**MOP AND BROOMSTICK HOLDER**



STOCK NO. CON515

**DUST PANS**



HEAVY GAUGE METAL. REINFORCED WITH CORRUGATED RIBS. BLACK ENAMELED FINISH.

STOCK NO. CON715 (12" WIDE)

STOCK NO. CON716 (16" WIDE)



RUGGED, INJECTION MOLDED PLASTIC.

STOCK NO. CON712 (12" WIDE)

**24" DUST MOP**



STANDARD 24" X 5" DUST MOP HEAD, 100% COTTON. 1-3/4" CUT-END FRINGE. ZIPPER OPENING. TOTAL HEIGHT 65". MACHINE WASHABLE IN MESH NET BAG. REFILL AVAILABLE.

STOCK NO. LIB922 (24" WIDTH)

STOCK NO. LIB923 (24" WIDTH REFILL)

**36" DUST MOP**



STANDARD 36" X 5" DUST MOP HEAD, 100% COTTON. 1-3/4" CUT-END FRINGE. ZIPPER OPENING. TOTAL HEIGHT 65". MACHINE WASHABLE IN MESH NET BAG. REFILL AVAILABLE.

STOCK NO. LIB924 (36" WIDTH)

STOCK NO. LIB925 (36" WIDTH REFILL)

**NOT  
SURE  
ABOUT  
SOMETHING?  
GIVE US  
A CALL!  
ONE OF OUR  
ASSOCIATES  
WILL BE  
MORE THAN  
HAPPY  
TO  
HELP  
YOU  
OUT.**

**SERVICE  
YOU CAN DEPEND ON !**



**MAINTENANCE BRUSHES**



**FLOOR BRUSHES**

- POLISHED HARDWOOD BLOCKS
- TWO THREADED HANDLE HOLES
- HANDLES NOT INCLUDED

**MEDIUM BLACK TAMPICO**



HIGH GLOSS CLEAR LACQUER BLOCK. 3" TRIM TAMPICO FIBER. EXCELLENT FOR SHOP OR STORE USE.

- STOCK NO. WE42007** (18" WIDTH)
- STOCK NO. WE42008** (24" WIDTH)
- STOCK NO. WE42047** (36" WIDTH BRACE INCLUDED)

**MEDIUM SYNTHETIC**



MEDIUM STIFF SYNTHETIC CENTER, FLAGGED SYNTHETIC BORDER, 3" TRIM. BRUSH SWEEPS FINE DUST & HEAVIER DEBRIS EFFECTIVELY.

**STOCK NO. BRMFB2936** (36")

**COARSE WIRE CENTER & TAMPICO BODY**



ONE ROW WIRE CENTER TO MOVE HEAVY REFUSE OR SWEEPING ROUGH FLOORS WHERE GREASE & METAL CHIPS ARE A PROBLEM. 3" TRIM.

- STOCK NO. WE42134** (18" WIDTH)
- STOCK NO. WE42135** (24" WIDTH)

**FINE SWEEPING SYNTHETIC FILL FLOOR BRUSH**  
 LONG SYNTHETIC FILL MATERIAL WILL NOT MAT IN USE. FLARED END TUFTS FOR CLOSER



SWEEPING TO WALLS. SHAPE PROVIDES BETTER CLEANING ACTION & LONGER BRUSH LIFE. 3" TRIM.

- STOCK NO. WE42041** (18" WIDTH)
- STOCK NO. WE42042** (24" WIDTH)

**MEDIUM SYNTHETIC FIBER**



FOR MEDIUM AND ROUGH FLOOR CLEANING. POLYPROPYLENE FILAMENT RESISTS OILS, GREASE, ETC. RESISTS HEAT & COLD BETTER THAN MOST PLASTIC FILLED BRUSHES.

- STOCK NO. WE42035** (18" WIDTH)
- STOCK NO. WE42037** (24" WIDTH)

**18" MULTI-SURFACE HEAVY DUTY PUSH BROOM**



3" LONG, COMBO OF FIRM AND FLEXIBLE SPLIT TIP POLYMER STAPLED FIBERS. 60" LONG STEEL HANDLE WITH 5" HANDGRIP AND HANGER HOLE. SUBER TOUGH POLYMER BRACE WON'T RUST OR BEND. POLYMER BLOCK FOR DURABILITY AND HYGIENE.

**STOCK NO. LIB824**

**24" MULTI-SURFACE HEAVY DUTY PUSH BROOM**



3" LONG, COMBO OF FIRM AND FLEXIBLE SPLIT TIP POLYMER STAPLED FIBERS. 60" LONG STEEL HANDLE WITH 5" HANDGRIP AND HANGER HOLE. SUBER TOUGH POLYMER BRACE WON'T RUST OR BEND. POLYMER BLOCK FOR DURABILITY AND HYGIENE.

**STOCK NO. LIB823**

**24" ROUGH SURFACE HEAVY DUTY PUSH BROOM**



4" LONG, COMBO OF FIRM AND FLEXIBLE SPLIT TIP POLYMER STAPLED FIBERS. 60" LONG STEEL HANDLE WITH 5" HANDGRIP AND HANGER HOLE. SUBER TOUGH POLYMER BRACE WON'T RUST OR BEND. POLYMER BLOCK FOR DURABILITY AND HYGIENE.

**STOCK NO. LIB825**

**36" HEAVY DUTY SMOOTH SURFACE BROOM**



3" LONG, SOFT POLYMER STAPLED FIBERS. 60" LONG STEEL, ZINC THREAD HANDLE WITH 5" HANDGRIP AND HANGER HOLE. SUPER TOUGH POLYMER BRACE WON'T RUST OR BEND. NATURAL HARDWOOD BLOCK.

**STOCK NO. LIB850** (36" WIDTH)

**24" MULTI-SURFACE HEAVY-DUTY INDUSTRIAL BROOM**



4" LONG COMBO OF FIRM AND FLEXIBLE SPLIT TIP POLYMER STAPLED FIBERS. 60" LONG WOOD HANDLE AND 15" ERGONOMIC GRIP WITH HANGER TIP. SUPER TOUGH POLYMER BRACE WON'T RUST OR BEND. NATURAL HARDWOOD BLOCK. ERGONOMIC GRIP ALLOWS FOR UPRIGHT SWEEPING TO MINIMIZE USER FATIGUE.

**STOCK NO. LIB827** (24" WIDTH)

**24" ROUGH SURFACE HEAVY-DUTY INDUSTRIAL BROOM**



4" LONG STIFF POLYMER STAPLED NON-FLAGGED FIBERS. 60" LONG WOOD HANDLE AND 15" ERGONOMIC GRIP WITH HANGER TIP. SUPER TOUGH POLYMER BRACE WON'T RUST OR BEND. RESIN BLOCK. ERGONOMIC GRIP ALLOWS FOR UPRIGHT SWEEPING TO MINIMIZE USER FATIGUE.

**STOCK NO. LIB829** (24" WIDTH)



**MAINTENANCE BRUSHES**



**HEAVY-DUTY GARAGE BRUSH**



STURDY BROWN PALMYRA FIBER. 4" TRIM LENGTH. ONE PIECE BLOCK. FOR ROUGH SURFACE SCRUBBING AND DRIVEWAY SWEEPING. NATURAL FIBERS FINE ENOUGH FOR GENERAL SWEEPING. HANDLE NOT INCLUDED.

STOCK NO. WE42022 (18" WIDTH)  
STOCK NO. WE42023 (24" WIDTH)

**16" STREET BROOM**



HEAVY-DUTY STREET AND MILL BROOM FOR GENERAL STREET OR HEAVY FLOOR SWEEPING. NATURAL AFRICAN BASS AND PALMYRA BLEND FIBER. MEDIUM COARSE. 6-1/4 TRIM LENGTH. USE ON BRICK OR CONCRETE SURFACES UNDER WET OR DRY CONDITIONS. SOLID, ONE PIECE HARDWOOD BLOCK. FLARED ON SIDES AND ENDS FOR SWEEPING CLOSE TO CURB OR WALLS. HANDLE NOT INCLUDED.

STOCK NO. WE42032 (STANDARD)  
STOCK NO. WE42033 (SYNTHETIC)

**BRACES**



**BIG CHIEF**

**SUPER CHIEF**

**BIG CHIEF** HANDLE BRACE FITS ON THE UNDER-SIDE OF THE HANDLE BETWEEN HANDLE AND BLOCK. REINFORCES AND LOCKS THE HANDLE TO THE BLOCK. BRACE IS EASILY ATTACHED WITH WING NUTS, AND IS REUSABLE.  
STOCK NO. WE44021

**SUPER CHIEF** HANDLE BRACE UTILIZES A STURDY STEEL STRAP WHICH CLAMPS AROUND HANDLE AND EXTENDS TO BLOCK WHERE IT FASTENS WITH SCREWS. THIS WIDE-ANGLE BRACE IS ESPECIALLY GOOD FOR LONG FLOOR BRUSHES. REUSABLE.  
STOCK NO. WE44290

**ADDITIONAL ITEMS  
AVAILABLE UPON REQUEST**

**YOUR  
SOURCE FOR  
INDUSTRIAL  
SUPPLIES!**



ONE OF THE ADVANTAGES OF BEING DISORDERLY IS THAT ONE IS CONSTANTLY MAKING EXCITING DISCOVERIES.

--A.A.MILINE

**HANDLES  
HARDWOOD TAPERED HANDLE**



FOR STREET BROOMS, DECK SCRUBS, WINDOW BRUSHES AND SQUEEGEES. 1-1/8" DIAMETER. UNTHREADED.

STOCK NO. WE44020 (5 FT. LENGTH)  
STOCK NO. WE44306 (6 FT. LENGTH)

**WOODEN HANDLE WITH CAST METAL TIP**



FOR FLOOR BRUSHES. 15/16" DIAMETER HARDWOOD. THREADED METAL TIP ELIMINATES BREAKAGE.

STOCK NO. WE44300 (5 FT. LENGTH)  
STOCK NO. WE44302 (6 FT. LENGTH)

**WOODEN HANDLE WITH CAST METAL TIP**



FOR FLOOR BRUSHES. 1-1/8" DIAMETER. 5FT. LENGTH.

STOCK NO. WE44019 (5 FT. LENGTH)

**PLASTIC REPLACEMENT TIP**



FITS 15/16" DIAMETER HANDLES.

STOCK NO. WE44317

**FIBERGLASS HANDLE WITH SYNTHETIC TIP**

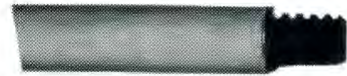

'SPACE AGE' SYNTHETIC TIP WILL ABSORB SHOCK THAT BREAKS OTHER TIPS. 1" DIAMETER. FIBERGLASS HANDLE OUTLASTS STANDARD WOOD HANDLES.

STOCK NO. BRMH60FG (5 FT. LENGTH)

**STEEL HANDLE**

60" LONG HANDLE WITH 5" HANDLE GRIP AND HANGER HOLE. DURABLE NYLON THREAD. REPLACEMENT HANDLE FOR ALL LIBMAN RESIN BLOCK, THREADED PUSH BROOMS.



STOCK NO. LIB601





**WIRE SCRATCH BRUSHES**



BENT HANDLE. TOOTHBRUSH STYLE. 8" OVERALL LENGTH; BRUSH PART 1-3/8"; TRIM LENGTH 1/2".

STOCK NO. LFT20060 (STAINLESS STEEL)  
STOCK NO. WE44189 (BRASS)



STANDARD. BENT HANDLE. 14" OVERALL LENGTH; BRUSH PART 6", TRIM LENGTH 1".  
STOCK NO. WE44053

STAINLESS STEEL BENT HANDLE  
STOCK NO. WE44054



STANDARD. SHOE HANDLE. 10" OVERALL LENGTH; BRUSH PART 5-1/4", TRIM LENGTH 1-3/16".  
STOCK NO. WE44063

BRASS WIRE SHOE HANDLE  
STOCK NO. WE44119



EXTRA HEAVY-DUTY SCRAPER BRUSH. WIDER AND HEAVIER FOR TOUGH JOBS. 12" OVERALL LENGTH; BRUSH PART 5-1/2", TRIM LENGTH 1-5/8"

STOCK NO. WE44069

**SANITARY BOWL BRUSH.**



WHITE TAMPICO FIBER FILL. TWISTED IN-WIRE CONSTRUCTION. 15" STRAIGHT WOODEN HANDLE.

STOCK NO. WE44001

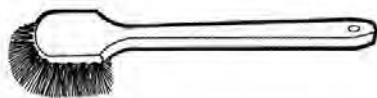

LONG HANDLE UTILITY SCRUB BRUSH. WHITE TAMPICO FIBERS. 20" OVERALL LENGTH.  
STOCK NO. WE44017

LONG HANDLE PLASTIC SCRUB BRUSH. 20" LONG. YELLOW SYNTHETIC BRISTLES.  
STOCK NO. WE79120

**MAINTENANCE BRUSHES**

**UTILITY BRUSHES  
SCRUB BRUSH**



SQUARE END WOODEN BLOCK.

STOCK NO. WE44024 (8" WHITE STIFF TAMPICO)

**DECK BRUSH**



CAN BE USED WITH WOOD HANDLE, STOCK NO. WE44020

STOCK NO. WE44026 (10" DECK PALMYRA FIBER)

**WOOD BLOCK NAIL BRUSH.**



PLASTIC FILL. 4-3/4" x 1-1/2" BLOCK SIZE.

STOCK NO. WE44314

**WIRE BLOCK BRUSHES**



FLAT STYLE. FOR HEAVY-DUTY CLEANING AND DESCALING. USED IN PIPELINE CLEANING MACHINES. PLAIN, WITH ONE-PIECE HARDWOOD BLOCK (7-1/2 x 2-3/4 x 1-1/4). .110 x .017 FLAT TEMPERED STEEL WIRE.

STOCK NO. WE44073

ROCKER FACE STYLE (NOT SHOWN). USED FOR PREPARING AND CLEANING FLAT PAINTED SURFACES. CURVED FACE GIVES GREATER LEVERAGE AND CONTROL. FLAT BLOCK 7-1/4 x 2-3/4.

STOCK NO. WE44066

**UTILITY SCRUB BRUSH**



SHORT HANDLE BRUSH. WHITE TAMPICO FIBERS. SOLID WOOD BLOCK. 8" OVERALL BRUSH LENGTH. IDEAL FOR CLEANING TIRES, BOATS AND REFUSE CONTAINERS.  
STOCK NO. WE44014

8" PLASTIC SCRUB BRUSH. ORANGE SYNTHETIC BRISTLES.  
STOCK NO. WE42211

**ACID BRUSHES**



ACID BRUSH FOR APPLYING ACID SOLDER. TIN FERRULE 5" LONG. HORSEHAIR FILL.

STOCK NO.	WIDTH INCHES	FERRULE DIA./INCHES	TRIM INCHES
RIM7420	5/16	3/16	3/4
WE44089	3/8	1/4	3/4
WE44090	1/2	5/16	3/4
MAGNOLIA3A	5/8	3/8	3/4



**PARTS CLEANING BRUSH**



PARTS CLEANING BRUSH FOR CLEANING ENGINE PARTS AND AROUND MOTORS. ROUND SASH TOOL TYPE. OVERALL LENGTH 11", DIA. OF FERRULE 15/16", TRIM LENGTH 2-3/4".

STOCK NO. WE40035 NYLON  
STOCK NO. WE40036 TAMPICO FIBER

**TRUCK WASH BRUSH**



TRUCK WASH BRUSH WITH SOFT, NON-SCRATCHING BRISTLES. 10" LONG. DOES NOT COME WITH HANDLE

STOCK NO. AP1103

**FLOW-THROUGH PARTS CLEANING BRUSH**



POLY-TUBE ATTACHES TO SPIGOT AND SOLUTION FLOWS THROUGH BRUSH. STIFF, RUGGED BRISTLES SHAPED TO PENETRATE CREVICES.

STOCK NO. GOOD52313

**MARKING BRUSH**



TIN FERRULE; LONG WHITE-WOOD HANDLE. 12" LENGTH; 1/4" DIAMETER.

STOCK NO. WE41008

**OVAL SASH TOOL**



100% HOG BRISTLE. CHISELED, NICKED FERRULE, EPOXY SET.

STOCK NO.	WIDTH	THICKNESS	BRISTLE LENGTH
WE40116	7/16	7/16	1-3/4
WE40117	1-1/8	1-1/8	2-1/2

**UNIVERSAL WIRE HAND BRUSH**



LONG WORKING LIFE. MAXIMUM REMOVAL CAPACITY. HIGH WIRE DENSITY FOR A HIGHER BRUSHING PRESSURE. NARROW FACE TO ALLOW EASY ACCESS INTO SLOTS. IDEAL FOR REMOVING RUST, PAINT, AND ANY KIND OF ADHERENCE, WELDING, CLEANING AND SCALE REMOVAL. OVERALL LENGTH 10 INCH, USABLE LENGTH 5 INCH, FACE WIDTH 5/8 INCH, TRIM LENGTH 1-1/8 INCH.

STOCK NO.	WIRE TYPE	WIRE DIA.
JAZ85100	COATED STEEL	.014
JAZ85150	BRASS	.012
JAZ85130	STAINLESS STEEL	.012



**PAINT BRUSHES, ROLLERS AND TRAYS**



**GENERAL PURPOSE TRIM BRUSHES**



100% CHINESE BRISTLE. WALNUT WOODEN BEAVERTAIL HANDLE. NICKEL FERRULE.

STOCK NO.	SIZE (WIDTH)	BRUSH THICKNESS	TRIM LENGTH
SORU83210	1"	7/16	1-7/8
SORU83215	1-1/2"	7/16	2"
SORU83220	2"	1/2	2"
SORU83230	3"	1/2	2-1/4
SORU83240	4"	5/8	2-1/2

**PREMIUM LATEX & OIL BRUSHES**



ONE COAT RESULTS. PREMIUM QUALITY TAPERED POLYESTER FILAMENTS. PLASTIC MOLDED HANDLE. BRASS PLATED FERRULE. EASY TO CLEAN.

STOCK NO.	SIZE (WIDTH)	BRUSH THICKNESS	TRIM LENGTH
SORU30501	1"	7/16	2-1/4
SORU305015	1-1/2"	1/2	2-1/2
SORU30502	2"	9/16	2-3/4
SORU30503	3"	11/16	3-1/4
SORU30504	4"	7/8	3-3/4

**SEMI-PRO TRIM BRUSHES**



100% TAPERED NYLON/POLYESTER FILAMENTS. WALNUT STAINED WOOD HANDLE. BRASS PLATED FERRULE. SUPERIOR PAINT RELEASE.

STOCK NO.	SIZE (WIDTH)	BRUSH THICKNESS	TRIM LENGTH
SORU53015	1-1/2"	1/2	2-1/2
SORU53015A	1-1/2"	7/16	2-1/4
SORU53020	2"	9/16	2-3/4
SORU53020A	2"	7/16	2-1/2
SORU53030	3"	11/16	3-1/4
SORU53040	4"	7/8	3-3/4

(STOCK NUMBERS WITH THE "A" SUFFIX ARE SASH BRUSHES)

**PAINT AND CHIP BRUSHES**



FOR GENERAL MAINTENANCE USE. 100% PURE BRISTLE. WOOD HANDLE. THROW-AWAY CONVENIENCE.

STOCK NO.	SIZE (WIDTH)	BRUSH THICKNESS	TRIM LENGTH
WE40065	1/2"	1/4	1-3/4
WE40066	1"	5/16	1-3/4
WE40067	1-1/2"	5/16	1-3/4
WE40068	2"	5/16	1-3/4
WE40070	3"	3/8	1-3/4
WE40071	4"	11/16	2-1/4

**MASONRY (KALSOMINE) BRUSHES (WHITE TAMPICO)**

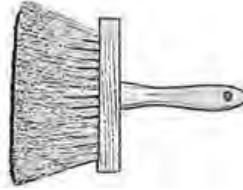

6-3/8 x 1-11/16 BLOCK SIZE. 4 ROWS. 3-1/2 TRIM LENGTH

STOCK NO. WE44031

7" x 7/8 BLOCK SIZE. TWO ROWS. 3-1/4 TRIM LENGTH.

STOCK NO. WE44032

**PROFESSIONAL ROLLER COVER**



SPECIAL KNIT POLYESTER FABRIC. OVEN BAKED PHENOLIC REINFORCED CORE.

STOCK NO.	SIZE	DESCRIPTION	NAP
SORU72719	9"	SEMI-SMOOTH	3/8
SORU72729	9"	SEMI-SMOOTH	1/2
SORU72739	9"	SEMI-ROUGH	3/4
SORU72749	9"	ROUGH	1-1/4

**ROLLER FRAME**



FINEST QUALITY HEAVY DUTY ROLLER FRAME. HAS A FIVE WIRE CAGE. NYLON END CAPS AND A THREADED SYNTHETIC PROFESSIONAL-GRIP HANDLE.

STOCK NO.	SIZE
SORU76890	9"

**PLASTIC TRAY LINER**



A REUSABLE, RECYCLABLE TRAY LINER MADE OUT OF DURABLE PLASTIC. HELPS EXTEND LIFE OF TRAY.

STOCK NO. SORU35569

**ROLLER TRAY**



2 QT. STANDARD DUTY METAL TRAY. LADDER LOCK LEGS TO HOLD IT IN PLACE. TRAY RAMP RIBBED FOR EVEN LOADING.

STOCK NO. SORU76429

**4" TRAFFIC MARKING ROLLER**



MEDIUM NAP ONE COAT ROLLER. 4 WIRE CONSUMER FRAME.

STOCK NO. SORU72434

4" ROLLER COVER REPLACEMENTS. TWIN-PACK MEDIUM NAP ONE COAT ROLLERS.

STOCK NO. SORU76434

**4 PC. PAINTERS ROLLER KIT**



BRIGHT STEEL TRAY. MULTI-USE ROLLER COVER. CONSUMER ROLLER FRAME. WOOD EXTENSION POLE.

STOCK NO. SORU11851590

**TWIST LOCK EXTENSION POLE**



THREADED TO FIT ALL STANDARD ROLLER FRAME HANDLES. ALUMINUM SNAP LOCK ADJUSTABLE POLE.

STOCK NO. SORU75540

**PAINT BUCKET GRID**



HEAVY DUTY PROFESSIONAL GRADE 5 GALLON PAINT BUCKET GRID.

STOCK NO. SORU74299



**MAINTENANCE BRUSHES**



**WIRE END BRUSHES**

WIRE END BRUSHES ARE PERMANENTLY MOUNTED ON A 1/4" STEM. EACH ARE MADE WITH THE HIGHEST QUALITY CRIMPED TEMPERED STEEL WIRE, WITH DENSE FILL AND A STURDY METAL HOUSING. REMOVES HARD CARBON DEPOSITS ON CYLINDERS, PISTON HEADS, RECESSES AND VALVE SEATS, AND ID PIPE CLEANING. FINER WIRE SIZES ARE USED FOR BLENDING, FINISHING AND POLISHING. ALSO USED IN DRILL PRESSES FOR DEBURRING AND RUBBER FLASH REMOVAL.

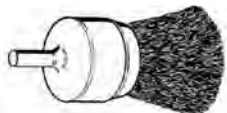

STOCK NO.	BRUSH FACE DIAMETER	WIRE SIZE
WE10005	3/4	.006
WE10008	3/4	.020
WE10012	1"	.020

**HEAVY-DUTY KNOTTED WIRE END BRUSHES**



STOCK NO.	BRUSH FACE DIAMETER	WIRE SIZE
WE10026	3/4	.020
WE10027	1-1/8	.014
WE10028	1-1/8	.020

**WIRE CUP BRUSH**



STOCK NO.	BRUSH FACE DIAMETER	WIRE SIZE
WE14301	1-3/4	.0118

**NARROW-FACE CRIMPED WIRE BRUSH.**



3/8" FACE WIDTH.

STOCK NO.	BRUSH DIAMETER	WIRE SIZE
WE17616	3"	.0118
WE17641*	3"	.0118

\*BRASS

**CIRCULAR FLARED END BRUSH**



STOCK NO.	BRUSH DIAMETER	WIRE SIZE
WE10038	1-1/2	.020

**KNOT WHEELS**



FOR GENERAL HEAVY-DUTY CLEANING, SUCH AS TIGHT SCALE OR SURFACE OXIDATION, RUBBER FLASH, HEAVY BURS, SURFACES TO BE WELDED, WELD SPATTER, AND SURFACE CONDITIONING. HIGH IMPACT ACTION. FAST, EFFICIENT CLEANING. USED ON STATIONARY OR PORTABLE TOOLS. GANGED OR INDIVIDUAL.

EFFICIENT CLEANING. USED ON STATIONARY OR PORTABLE TOOLS. GANGED OR INDIVIDUAL.

**STANDARD TWIST - REGULAR FACE**

STOCK NO.	DIA.	WIRE SIZE	FACE WIDTH	ARBOR HOLE
WE08044	4"	.014	1/2	3/8-1/2
WE13266	4"	.020	1/2	5/8-11
WE08085	6"	.014	1/2	1/2-5/8
WE08105	6"	.023	1/2	1/2-5/8
WE08155	8"	.023	5/8	5/8
08189	10"	.016	3/4	1-1/4
WE08219	12"	.016	3/4	1-1/4



USED FOR CONFINED AREAS. MAXIMUM NUMBER OF KNOTS FOR LONG LIFE. AGGRESSIVE ACTION. APPLIED TO CROSS COUNTRY PIPE LINES, PIPE FABRICATION, AND BRUSHING EXPANSION JOINTS.

**STRINGER BEAD TWIST 3/16 NARROW WORK FACE**

STOCK NO.	DIA.	WIRE SIZE	TRIM LENGTH	ARBOR HOLE
WE13127	4"	.020	7/8	M14 x 2.0
WE13130	4"	.020	7/8	1/2-13
WE13131	4"	.020	7/8	5/8-11
WE08756	5"	.020	7/8	5/8-11
WE09400	6"	.020	7/8	5/8-11

**COPPER CENTER WHEELS**



HIGH SPEED CLEANING FOR INTERNAL, OUT-OF-THE-WAY PLACES. WIRE SIZES .002 - .014. RPMs UP TO 20,000. SMALL DIA.

STOCK NO.	DIA.	WIRE SIZE	FACE WIDTH	ARBOR HOLE
WE15151	1-3/8	.0104	1/4	1/4
WE15443	2"	.008	3/8	1/2
WE15473	2"	.014	3/8	1/2
WE15543	3"	.008	5/8	1/2
WE15563	3"	.0118	5/8	3/8

**CRIMPED WIRE WHEEL BRUSHES**



NARROW FACE WIRE WHEELS FOR GENERAL DUTY OR FINE PRODUCTION WORK, SUCH AS LIGHT BURS, LIGHT SCALE, RUST, OR CORROSION (ESPECIALLY IN NARROW OR UNEVEN SURFACES). USED SINGLY OR GANGED

IN MULTIPLES. EXTRA-HEAVY FILL FOR FAST CUTTING AND LONG LIFE.

STOCK NO.	DIA.	WIRE SIZE	APPROX. FACE	TRIM LGTH.	ARBOR HOLE
WE00144	4"	.014	1/2	7/8	3/8, 1/2
WE01075	6"	.014	1/2	1-7/16	1/2, 5/8
WE01175	8"	.014	13/4	2-1/16	5/8
WE01135	8"	.006	1/2	2-1/16	5/8

**CRIMPED WIRE WHEEL BRUSHES WITH FIXED THREADED ARBOR**

STOCK NO.	DIA.	WIRE SIZE	APPROX. FACE	TRIM LGTH.	ARBOR HOLE
WE13077	4"	.014	1/2	7/8	M-14 x 2.0
WE13081	4"	.014	1/2	7/8	5/8-11

**WIDE FACE ADAPTER WIRE WHEELS**



FOR ALL PURPOSE PORTABLE OR STATIONARY BRUSHING, SUCH AS REFINISHING METAL SURFACES, REMOVING RUST, CORROSION AND PAINT, PREPARING RUBBER IN VULCANIZING, AND BLENDING SURFACES. DENSE AND COMPACT,

WITH A STANDARD 2" OPENING. CRIMPED STEEL. A PAIR OF METAL ADAPTERS ARE REQUIRED WITH EACH WHEEL (SEE NEXT PAGE FOR ADAPTERS). ADAPTABLE TO ARBOR SIZES 3/8, 1/2, 5/8, 3/4, 7/8, 1, 1-1/4, 1-1/2.

STOCK NO.	DIA.	WIRE SIZE	APPROX. FACE	TRIM LGTH.	ARBOR HOLE
WE06080	6	.014	1"	1-1/8	2"
WE03070	6	.014	1-1/4	1-1/8	2"
WE06655*	7	.014	7/8	1-5/8	5/8
WE06120	8	.014	1"	1-3/8	2"
WE03200	10	.014	2"	1-7/8	2"

\*FURNISHED WITH A 1/2-5/8 ADAPTER

**ADAPTERS FOR WIRE WHEEL BRUSHES**



METAL ADAPTERS LISTED BELOW MUST BE USED IN PAIRS. ORDER SEPARATELY.

STOCK NO.	ARBOR HOLE
WE03809	1/2
WE03810	5/8
WE03811	3/4
WE03824	7/8
WE03812	1"
WE03813	1-1/4



**MAINTENANCE BRUSHES**



**CRIMPED WIRE CUP BRUSHES**



SOFTER BRUSHING ACTION THAN KNOT CUP BRUSHES. ESPECIALLY SUITABLE FOR OVERHEAD WORK. STURDY STEEL CUP WITH HIGH TENSILE STEEL WIRE.

**STANDARD CRIMPED WIRE CUP BRUSH TRIM LENGTH 1-1/2**

STOCK NO.	DIA.	WIRE SIZE	ARBOR
WE14026	4"	.014	5/8-11
WE14066	6"	.014	5/8-11
WE14076	6"	.020	5/8-11

**MINI-GRINDER CRIMPED WIRE CUP BRUSH TRIM LENGTH 7/8**

STOCK NO.	DIA.	WIRE SIZE	ARBOR
WE13242	3"	.014	M14 x 2.0
WE13244	3"	.014	1/2-13
WE13245	3"	.014	5/8-11

**WIRE WHEEL ARBOR**



FOR USE IN PORTABLE TOOLS AND DRILL PRESSES HAVING 1/4" CAPACITY CHUCKS. LEFT-HAND THREAD FOR POSITIVE LOCK. 1/4" SHANK. 1/2" DIAMETER BRUSH ARBOR.

STOCK NO. WE07724

**GRINDER ADAPTERS**



ADAPTS WIRE BRUSHES AND OTHER FINISHING WHEELS THAT HAVE A 5/8-11 ID TO VARIOUS POWER GRINDING TOOLS. THREAD SIZE IMPRINTED ON EACH ADAPTER. MACHINED FROM HEX STOCK. PLATED FINISH. 3/4" OVERALL LENGTH. 1/2" MALE THREAD LENGTH.

STOCK NO. INTERNAL THREAD SIZE

CLEDGA3824	3/8-24
CLEDGA125MM	M10 x 1.25 MM
CLEDGA15MM	M10 x 1.5 MM

**EXTRA HEAVY-DUTY KNOT CUP BRUSHES**



FOR FAST CLEANING WITH PORTABLE TOOLS: PIPE, STRUCTURAL STEEL, WELDS, TANK CARS, SHIP BOTTOMS, ETC. STEEL CUP AND KNOT CONSTRUCTION GIVE RIGIDITY AND PREVENT BENDING OR PANCAKING. HIGHEST QUALITY TEMPERED STEEL WIRE.

**SINGLE ROW**

-LIMITED FLARE FOR CORNERS AND ANGLES  
-GENERAL HEAVY-DUTY USE

STOCK NO.	ARBOR	DIA. FACE	WIRE SIZE	TRIM LGTH.
WE12746	5/8-11	3-1/2	.020	1-1/4
WE12316	5/8-11	4"	.023	1-1/4
WE12306	5/8-11	4"	.014	1-1/4
WE12846	5/8-11	6"	.014	1-5/8

**DOUBLE ROW**

-EXTRA HEAVY-DUTY USE  
-GREATER SURFACE COVERAGE  
-LONGER WEAR

STOCK NO.	ARBOR	DIA. FACE	WIRE SIZE	TRIM LGTH.
WE12576	5/8-11	6"	.035	1-3/8
WE12556	5/8-11	6"	.023	1-3/8

**2-3/4" HEAVY-DUTY KNOT CUP BRUSH FOR MINI-GRINDERS**

-.020 WIRE SIZE  
-1" TRIM LENGTH

STOCK NO.	APPROX. DIA. FACE	THREADED ARBOR HOLE
WE13286	2-3/4	5/8-11
WE13283	2-3/4	M14 x 2.0
WE13282	2-3/4	M10 x 1.5
WE13281	2-3/4	M10 x 1.25

**HAVING TROUBLE  
FIND SOMETHING?  
GIVE US A CALL.  
WE WILL BE MORE  
THAN HAPPY TO  
ASSIST YOU!**

**POWER TYPE TUBE BRUSH**



LIGHT DUTY CLEANING OF ECCENTRIC AND RECTANGULAR HOLES. USED IN DRILL PRESSES, BENCH GRINDERS AND PORTABLE TOOLS. STEEL STEM.

**CARBON STEEL WIRE**

STOCK NO.	DIA.	BRUSH LGTH.	OVERALL LGTH.	WIRE SIZE
WE21232	3/8	1-1/2	4"	.006
WE21107	1/2	2"	5"	.006
WE21109	5/8	2"	5"	.008
WE21110	3/4	2-1/2	5-1/2	.006
WE21115	1"	2-1/2	5-1/2	.010

**STAINLESS STEEL WIRE**

WE21125	1"	2-1/2	5-1/2	.010
---------	----	-------	-------	------

**ECONOMY POWER TYPE TUBE BRUSH**



IDEAL TOOL FOR INTERNAL THREAD CLEANING AND DEBURRING. CONSTRUCTED OF STAINLESS STEEL STEM WIRE.

STOCK NO.	DIA.	BRUSH LENGTH	OVERALL LENGTH
-	1/4	1"	3-1/2
WE21073	3/8	1"	3-1/2
WE21074	1/2	1"	3-1/2
-	5/8	1"	3-1/2
WE21076	3/4	1"	3-1/2
-	7/8	1"	3-1/2
-	1"	1"	3-1/2

**TUBE BRUSHES**



USED FOR INTERNAL CLEANING AND BRUSHING. BLACK NYLON FILL MATERIAL. TWISTED-IN-WIRE CONSTRUCTION.

STOCK NO.	DIA.	BRUSH LENGTH	OVERALL LENGTH
WE44110	1/4	2"	6"
WE44213	3/8	2"	6-1/4
WE44111	1/2	3"	8-1/2
WE44112	3/4	3"	8-1/2



**TORCHES, KITS & ACCESSORIES**



**PROPANE FUEL CYLINDER**



16 OZ. DISPOSABLE STEEL PROPANE CYLINDER. FOR USE WITH ANY BERNZOMATIC TORCH OR APPLIANCE.

STOCK NO. BERTX9C

**JUMBO TORCH BURNER UNIT**



ALL BRASS, PRECISION NEEDLE VALVE CONTROLLED TORCH. JET PUMP AIR INTAKE SYSTEM PROVIDES

PROPER AIR/FUEL MIXTURE AND EFFECTIVE HEAT OUTPUT. PRODUCES A LARGE, HIGH-VOLUME 1-1/4" FLAME FOR REMOVING PAINT, TILE WORK AND MORE. BURNS PROPANE FUEL.

STOCK NO. BERJT680C

**PENCIL FLAME TORCH BURNER UNIT**



ALL BRASS, PRECISION NEEDLE VALVE CONTROLLED TORCH. JET PUMP AIR INTAKE SYSTEM PROVIDES

PROPER AIR/FUEL MIXTURE AND EFFECTIVE HEAT OUTPUT. PRODUCES A 1/2" PENCIL POINT FLAME FOR DETAIL WORK. BURNS PROPANE FUEL.

STOCK NO. BERJT681C

**BLOW TORCH BURNER HEAD**



GIVES HEAVY-DUTY BLOW TORCH FLAME.

STOCK NO. BER700

**PENCIL FLAME TORCH TIP**



GIVES FINE PENCIL FLAME.

STOCK NO. BER81264

**TORCH TIP CLEANER**



STANDARD SET OF 13 CLEANERS WITH FILE. SIZE #6 THRU 26 FOR CLEANING DRILL SIZE 77-49. RUST-PROOF STAINLESS STEEL WIRE. ALUMINUM CASE.

STOCK NO. EW05

**MAPP GAS FUEL CYLINDER**



16 OZ. DISPOSABLE STEEL MAPP GAS CYLINDER. FOR USE ON THE JT-539 TORCH HEAD (SHOWN BELOW).

STOCK NO. BERMG9

**MAPP GAS TORCH HEAD**



PRESSURE REGULATED SWIRL FLAME BRAZING TORCH UNIT. AUTOMATIC REGULATED PRESSURE. MAXIMUM HEAT OUTPUT. SOLID BRASS CONSTRUCTION. BURNS EITHER PROPANE OR MAPP GAS FOR A HOTTER FLAME.

STOCK NO. BERJT539

**JET TORCH FLAME SPREADER**



NO SCREW, SNAP ON/OFF FLAME SPREADER GIVES BROAD, FLAT FLAME.

STOCK NO. BER810

**FLINT SPARK LIGHTER**



LIGHTS ALL PROPANE OR OTHER WELDING APPLIANCES QUICKLY AND EASILY. LIGHT-WEIGHT AND BUILT TO LAST.

STOCK NO. EW12

**FLINT RENEWALS**



SINGLE FLINT FOR STANDARD LIGHTERS. 5/BX.

STOCK NO. EW13



TRIPLE FLINT FOR HEAVY-DUTY JOBS. 4/PK.

STOCK NO. EW15

**7-PIECE PROPANE TORCH KIT**



A DELUXE 7-PIECE SOLID BRASS JET TORCH KIT, INCLUDING A HANDY MOLDED PLASTIC STORAGE CASE. INCLUDES: PENCIL FLAME BURNER UNIT, BLOW TORCH BURNER HEAD, FLAME SPREADER, SPARK LIGHTER, FLINT RENEWALS, AND PROPANE CYLINDER. UL LISTED. UP TO 15 HOURS BURNING TIME.

STOCK NO. BERJT25

**INSTANT FIRE TORCH KITS**



TRIGGER ACTIVATED IGNITOR PRODUCES AN INSTANT FLAME. FULLY ADJUSTABLE. TORCH STAYS ON WHEN TRIGGER IS RELEASED. HEAD ANGLE IS LIKE A CONVENTIONAL TORCH. KIT INCLUDES TORCH UNIT AND PROPANE CYLINDER.

STOCK NO. BERTS3000KC

CUSTOMER  
 SATISFACTION  
 IS  
 THE  
 KEY  
 TO  
 OUR  
 SUCCESS

CALL FOR COMPLETE  
 SPECIFICATIONS  
 AND PRICES

# Weller®

## HEAT TOOLS FOR INDUSTRY

# MASTER® APPLIANCE

### SOLDERING GUN KIT



8 PIECE HEAVY-DUTY SOLDERING KIT INCLUDES WELLER MODEL D550 WITH TIN PLATED COPPER TIP, 1 SEALING TIP, 1 CUTTING TIP, 1 FLUX BRUSH, SOLDERING AID TOOL, 1 COIL OF 40/60 ROSIN CORE SOLDER AND STURDY PLASTIC CASE. UL LISTED.

STOCK NO. WELD550PK

### REPLACEMENT SOLDER GUN TIP



STOCK NO. WEL7250  
STOCK NO. WEL6140AN (W/NUTS)

### SOLDERING IRONS



FEATHERWEIGHT SOLDERING IRON WITH PENCIL HANDLE AND REPLACEABLE TIP. DESIGNED FOR HOBBIES, KITS, RADIOS. 8-1/4" LONG. TIP DEVELOPS TO 750°F.

STOCK NO. WELSP23

### REPLACEMENT SOLDER TIP

STOCK NO. WELMT1 (2/PACK)

LIGHTWEIGHT PENCIL IRON FOR HOBBY AND ELECTRONIC WORK. 8-1/4" LONG. TIP DEVELOPS TO 900°F.

STOCK NO. WELSP40

### REPLACEMENT SOLDER TIP

STOCK NO. WELMT10 (2/PACK)

ADDITIONAL ITEMS AVAILABLE  
UPON REQUEST

### SELF-IGNITING ULTRATORCHES



ECONOMICAL CORDLESS ULTRATORCH IS A COMBINATION PORTABLE SOLDERING IRON AND FLAMELESS HEAT TOOL. INCLUDES SOLDER/HEAT TIP, SPANNER AND OPEN-END WRENCH, SHRINK ATTACHMENT AND PROTECTIVE CAP. SOLDERING TIP TEMPERATURE 482 - 932°F. HEAT TIP TEMPERATURE 1202°F. APPROX. 10" LONG.

STOCK NO. MHUT100SI

JUMBO CORDLESS ULTRATORCH IS ALSO A COMBINATION PORTABLE SOLDERING IRON AND FLAMELESS HEAT TOOL, BUT WITH MORE BTU'S. INCLUDES SOLDER/HEAT TIP, SPANNER AND OPEN-END WRENCH, SHRINK ATTACHMENT, EJECTOR AND PROTECTIVE CAP. SOLDERING TIP TEMPERATURE 572 - 986°F. HEAT TIP TEMPERATURE 1292°F. APPROX. 11" LONG. BOTH BUTANE POWERED.

STOCK NO. MHUT200SI

### MINI ULTRATORCH KIT



PROFESSIONAL QUALITY YET ECONOMICAL. SELF-IGNITING AND REFILLABLE. BUTANE GAS POWERED. CAN BE USED AS A SOLDERING IRON, HEAT TOOL OR HOT KNIFE. ADJUSTABLE TEMPERATURE UP TO 1,200°F. OPERATES UP TO 1-1/4 HOURS PER REFILL.

STOCK NO. MHUT40SIK

### SERVICE WITH A SMILE.



### BUTANE MICROTORCHES



MT10



MT50

MT10 BUTANE POWERED MICROTORCH RUNS OFF OF REFILLABLE FUEL CELL (INCLUDED). 2400°F. FLAME TEMPERATURE. STOCK NO. MHMT10

MT50 BUTANE POWERED MICROTORCH INCORPORATES A BUILT-IN FUEL TANK. RUNS OFF OF ULTRATANE BUTANE. 2 HR. RUN TIME ON FULL CHARGE. 2400°F. FLAME TEMP. FUEL NOT INCLUDED.

STOCK NO. MHMT50

### BUTANE REFILLS



FUEL CELL FOR MT10 MICROTORCH. 2 PER PACK.

STOCK NO. MH35319

ULTRATANE 5-1/8 OZ. BUTANE REFILL FOR 40SIK, MT50, UT100SI, AND UT200SI.

STOCK NO. MH51773



THIS SPACE RESERVED  
FOR FUTURE HEATING TOOLS



**HEAT TOOLS FOR INDUSTRY**



**HEAT GUNS**

**MASTER HEAT GUN**



HEAVY-DUTY INDUSTRIAL QUALITY HEAT GUN. 10" L x 5.25" W x 9.5" H. TEMPERATURE NOZZLE FROM 500 - 750°F. 1680 WATTS. IDEAL FOR FREEZER COILS, PLASTIC LAMINATES, CIRCUIT BOARDS, PVC, FIBERGLASS OR HEAT-SHRINKABLE MATERIALS. DIECAST ALUMINUM HOUSING.

**STOCK NO. MHHG501A**

**MASTER HEAT GUN**



HEAVY-DUTY INDUSTRIAL QUALITY HEAT GUN. 10" L x 5.25" W x 9.5" H. TEMPERATURE NOZZLE FROM 750 - 1000°F. 1740 WATTS. IDEAL FOR FREEZER COILS, PLASTIC LAMINATES, CIRCUIT BOARDS, PVC, FIBERGLASS OR HEAT-SHRINKABLE MATERIALS. DIECAST ALUMINUM HOUSING.

**STOCK NO. MHHG751B**

**PROHEAT HEAT GUN**



COMPACT AND LIGHT-WEIGHT HEAT GUN. 8.25" L x 3" W x 7.3" H. TEMPERATURE SETTINGS OF 570 & 1050°F (750 & 1500 WATTS). ADAPTABLE FOR A WIDE VARIETY OF USES, INCLUDING AIRCRAFT AND MARINE APPLICATIONS. BUILT-IN HAND AND SWITCH GUARD. 3-WIRE CORD SET. WRAP-AROUND AIR INTAKE. IDEAL FOR SHRINKABLE PACKAGING MATERIALS AND FOR SPOT-DRYING PAINT, BENDING PLASTICS OR ACTIVATING ADHESIVES.

**STOCK NO. MPPH1100**

**MASTER-MITE HEAT GUN**



A COMPLETE BENCH TOP HEATING GUN SYSTEM. INCLUDES ADJUSTABLE STAND. 650°F. HEATING ELEMENT AND A HEAT SHRINK ATTACHMENT. LIGHT-WEIGHT. 8.9" L x 3.4" W x 7" H. LOW POWER DRAW AND QUIET OPERATION.

**STOCK NO. MH10008**

**HEATING ELEMENTS**



**STOCK NO. MHHAS011K** (FOR MODEL HG501A)  
**STOCK NO. MH35004** (FOR MODEL PH1100)

**ECOHEAT HEAT GUN**



AN ECONOMICAL, LIGHTWEIGHT, MULTI-USE HEAT GUN. LIGHTWEIGHT AND EASY TO HOLD AT ANY ANGLE FOR LONG PERIODS OF TIME. THERMOPLASTIC CASE GIVES HIGH IMPACT DURABILITY. USE TO BEND AND FORM PLASTICS, DRY

BODY FILLERS, REMOVE DECALS, SPOT DRY PAINT, SHRINK TUBING, PACKAGING AND MORE. BUILT-IN HAND SWITCH GUARD PROTECTING HAND, FINGERS, AND SWITCH FROM UNWANTED KNOCKS AND BUMPS.

**STOCK NO. MHEC100**

**PIPE HEATING CABLE**



HELPS TO PREVENT FROZEN WATER PIPES. TO BE USED ON PIPES CONTAINING WATER ONLY. THERMOSTAT ACTIVATED. 120 VOLT.

STOCK NO.	LENGTH
WRAP31009	9'
WRAP31018	18'
WRAP31030	30'
WRAP31060	60'

**THIS SPACE RESERVED  
 FOR FUTURE INVENTORY  
 ITEMS**

**ADDITIONAL ITEMS AVAILABLE  
 UPON REQUEST**

### WELDING SUPPLIES

#### ELECTRODE HOLDER



LIGHT WEIGHT AND EASY TO USE. MADE FROM HIGH QUALITY MATERIALS FOR BOTH HIGH CONDUCTIVITY AND IMPROVED CABLE CONNECTIONS. FULLY INSULATED WITH HIGH HEAT AND IMPACT RESISTANT NYLON THAT IS LIGHTWEIGHT, STRONG AND COOL IN RUNNING. SUPPLIED WITH AN ALLEN WRENCH AND CABLE CONNECTION FERRULE. 250 AMP CAPACITY.

STOCK NO. EW60

#### GROUND CLAMP



LARGE CONTACT AREA ASSURES POSITIVE GROUNDING. UNIQUE DESIGN HELPS ELIMINATE ARC BLOW AND MAKES IT EASY TO CHANGE GROUND LOCATION FOR THE BEST RESULTS. 300 AMP CAPACITY

STOCK NO. EW61

#### MULTI-GRIP WELDING CLAMP



SERRATED FORGED STEEL JAWS. HARDENED STEEL RAILS. CLAMPING PRESSURE NUT/SCREW ADJUSTMENT. 2" NOM. OPENING. 1-3/4" THROAT DEPTH. 330 LB. PRESSURE.

STOCK NO. JMSG2

#### WELDERS' ANGLE CLAMP



SELF-CENTERING FIXTURE VISE THAT HOLDS THE WORKPIECE AT 90 DEGREES FOR WELDING (T-JOINTS, ETC.). CAST IRON. TOTAL CAPACITY 7". 1-1/2" JAW HEIGHT; 4" JAW LENGTH. 2-1/2" PASSAGE FOR T-JOINTS.

STOCK NO. JMWSM9

#### WELDER'S ANTI-SPLATTER



**POWDER:** NON-FLAMMABLE. DRIES TO A WHITE FILM. PREVENTS SPATTER FROM STICKING TO METAL SURFACES. FILM EXPOSES CRACKS IN WELDS. EASILY REMOVED BY WIPING. DOES NOT CONTAIN SILICONE. SURFACE CAN BE PAINTED AFTER USE.

STOCK NO. SO541



**LIQUID:** NON-FLAMMABLE. KEEPS WELDING TIPS AND NOZZLES CLEAN. NON-GREASY. EFFECTIVE FOR ALL TYPES OF WELDING, ESPECIALLY MIG AND TIG TIPS. DOES NOT CONTAIN SILICONE. SURFACE CAN BE PAINTED AFTER USE.

STOCK NO. SO542

#### BRONZE BRAZING ROD



A LOW-FUMING OXY-ACETYLENE BRAZING ROD EXTENSIVELY USED FOR JOINING OF STEELS AND OVERLAYING OF CAST IRON. MELTING POINT 1620°F. 1/8" SIZE, 36" LENGTH. SOLD PER PIECE.

STOCK NO. EW40

#### WELDING ROD

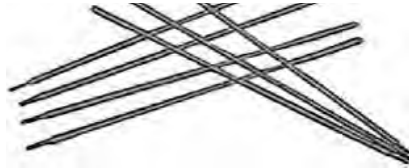

1/8" STICK ELECTRODES - SOLD PER 5 LB. BOX

**E6011-** EXCELLENT MECHANICAL PROPERTIES IN WELDING MILD STEELS, GALVANIZED, AND SOME LOW ALLOY STEELS. COATING PRODUCES SPRAY-TYPE ARC FOR DEEP PENETRATING WELDS. SLAG IS THIN AND READILY REMOVABLE. OPERATES ON AC OR DCEP.

STOCK NO. EW42

**E6013-** SMOOTH AND QUIET MEDIUM PENETRATING ARC. SLAG LIFTS EASILY AND IS QUICK-FREEZING FOR OPTIMUM PERFORMANCE. IDEAL FOR GENERAL PURPOSE WELDING. WORKS WELL ON AC AND DC.

STOCK NO. EW44

**E7014-** IRON POWDER COVERING. SMOOTH BEAD WELD WITH FINE RIPPLES. SLAG REMOVES EASILY. OPERATES ON AC, DCEN OR DCEP.

STOCK NO. EW46

**E7018-** ALL-POSITION. IRON POWDER ELECTRODE WITH EXCELLENT MECHANICAL PROPERTIES. QUIET, STABLE, LOW PENETRATION SPATTER-FREE ARC. MODERATELY HEAVY SLAG IS EASILY REMOVED. OPERATES ON AC OR DCEP.

STOCK NO. EW48

#### FLEXIBLE WELDING CABLE



A HIGHLY FLEXIBLE TE\*PRENE JACKET WELDING CABLE WITH FULLY ANNEALED ROPE STRANDED BARE COPPER. A HEAVY-DUTY CABLE RESISTANT TO FLAME, OIL, ABRASIVE, TAR AND GREASE. TEMPERATURE RANGE: -40°C TO +105°C. RATED AT 600 VOLTS. BLACK. SOLD PER FOOT.

STOCK NO. GAUGE

EC10011	6 GA
EC10012	4 GA
EC10013	2 GA
EC10015	1/0
EC10016	2/0
EC10017	3/0

#### MIG WELDING WELDING



ER70S6 MILD STEEL WELDING WIRE WITH HIGH MANGANESE AND SILICON CONTENT. PRODUCES POROSITY-FREE, X-RAY QUALITY, WELDS AT THE HIGHEST TENSILE STRENGTH OF ALL THE PLAIN CARBON STEEL WIRES. REQUIRES A SHEILDING GAS OF CO2 AND OR CO2 MIX. TENSILE STRENGTH 85,000 PSI.

STOCK NO.	DESC	WEIGHT
EW303	.023 MIG WELDING WIRE	12 LBS
EW306	.030 MIG WELDING WIRE	33 LBS
EW309	.035 MIG WELDING WIRE	44 LBS
EW310	.045 MIG WELDING WIRE	44 LBS

#### TWIN WELDING HOSE



ABRASION, WEATHER AND OZONE RESISTANT. WORKING PRESSURE 200 PSI. TWIN LINE HOSE IS OXYGEN AND ACETYLENE HOSE JOINED TOGETHER. 1/4" HOSE. 50' ROLL.

STOCK NO. EW10

#### FLINT SPARK LIGHTER



LIGHTS ALL TORCHES QUICKLY AND EASILY. LIGHTWEIGHT AND BUILT TO LAST.

STOCK NO. EW12

#### WELDER'S MAGNETIC SQUARES



USE TO HOLD SHEET STEEL, PIPES, RODS OR OTHER COMPONENTS EXACTLY IN POSITION WHILE WELDING/ SOLDERING/BRAZING

STOCK NO. DESCRIPTION

JMWMS1	OPEN TYPE
JMWMS2	ENCLOSED TYPE

#### WELDER'S CHIPPING HAMMER



HEAT-TREATED HIGH ALLOY STEEL ASSURES LONG LIFE FOR THIS HEAVY DUTY TOOL. A MUST IN EVERY WELDING SHOP. ONE POINT PICK END AND ONE 5/8" CHISEL END.

STOCK NO. DESCRIPTION

EW07	WIRE HANDLE
------	-------------



**WELDING SUPPLIES**

**WELDING JACKET**



30" LENGTH. FLAME-RESISTANT. FULL-LENGTH SLEEVES. SNAP CUFF. GREEN COTTON.

STOCK NO. ELLRG3M (MEDIUM)  
STOCK NO. ELLRG3L (LARGE)  
STOCK NO. ELLRG3XL (EXTRA-LARGE)

**WELDERS APRON**



24" x 42". FLAME-RESISTANT. GREEN COTTON. ADJUSTABLE NECK.

STOCK NO. EW25

**QUALITY LEATHER GLOVES**



PREMIUM QUALITY WELDERS GLOVE FEATURING SPECIAL WELDERS TANNED LEATHER. FULL FLEECE LINING FOR BOTH THE PALM AND BACK OF HAND. ONE PIECE BACK-NO SEAMS TO RUB ON BACK OF HAND. ALL MAJOR SEAMS WELDED.

STOCK NO. GLV575

**DOO-HATS**



MADE FROM 100% COTTON FABRIC. AVAILABLE IN ASSORTED PRINTS. IDEAL FOR BREATHABLE COMFORT WHEN WORN ALONE OR UNDER WELDING HELMET OR HARDHAT. ALL COME WITH SEWN IN SWEATBANDS.

STOCK NO.	COLOR
DHUB613B	BLUE DOO-HAT
DHUB613C	CAMOUFLAGE DOO-HAT
DHUB613D	DENIM DOO-HAT
DHUB613F	WAVY FLAG DOO-HAT
DHUB613M	BIKE DOO-HAT
DHUB613R	RED DOO-HAT

**WELDERS GOGGLES**



SOFT FRAME FLEXIBLE VINYL WITH 50mm PLASTIC WELDING LENSES. WELL VENTILATED, COMFORTABLE. LENSES ARE REPLACEABLE. WILL FIT OVER PRESCRIPTION EYE WEAR. SHADE #5 LENS.

STOCK NO. USS170



SOFT FRAME FLEXIBLE VINYL WITH 2" x 4 1/4" HARDENED WELDING LENS IN HINGED FRAME FOR LIFT-UP POSITION. WITH CLEAR POLYCARBONATE LENS FOR VIEWING PROTECTION WHEN IN LIFT-UP POSITION. SIX VENTILATION PORTS FOR MAXIMUM VENTILATION. LENSES ARE REPLACEABLE. SHADE #5 LENS.

STOCK NO. USS172



SOFT FRAME FLEXIBLE VINYL WITH 2" x 4-1/4" HARDENED WELDING LENS. LENSES ARE REPLACEABLE. SIX VENTILATION PORTS FOR MAXIMUM VENTILATION. WILL FIT OVER PRESCRIPTION EYE WEAR. SHADE #5 LENS.

STOCK NO. USS171

**AUTO DARKENING WELDING HELMET**



ULTRA LIGHT HIGHLY DURABLE HELMET WITH MOLDED WINDOW. DESIGNED WITH THE UNDERSTANDING THAT A WELDING ENVIROMENT IS TYPICALLY KNOWN FOR BEING UNFORGIVING ON PERSONAL PROTECTIVE EQUIPMENT. COMES WITH SOLERA SOLAR POWERED AUTO-DARKENING FILTER. MEETS ANSI SPECIFICATIONS.

STOCK NO. USS079

**FIBERGLASS CURVED CHIN WELDING HELMET W/ PLATES - LIFT FRONT MODEL**



COMES WITH 2" x 4-1/4" WELDER'S PLATE - SHADE #10 AND A 2" x 4-1/4" POLYCARBONATE BACK-UP PROTECTIVE PLATE. MEETS ANSI Z87.1 SPECIFICATIONS.

STOCK NO. USS075

**REPLACEMENT HEADGEAR**

STOCK NO. USS078

**FIBERGLASS CURVED CHIN WELDING HELMET W/ WIDE-VISION PLATE, STATIONARY FRONT MODEL**

FIBERGLASS HEAVY DUTY SHELL RESISTS MOISTURE, HEAT, IMPACT AND WELDING SPATTER. RATCHET HEADBAND ADJUSTMENT. EXTRA WIDE VISION PLATE FOR GREATER LATERAL AND PANORAMIC VIEWING. COMES WITH A 4-1/2" x 5-1/4" GLASS WELDERS PLATE, SHADE #10. EXTRA DURABLE, NON-FLAMMABLE AND EXCELLENT SHAPE STABILITY. MEETS ANSI SPECIFICATIONS.



STOCK NO. USS077

**REPLACEMENT HEADGEAR**

STOCK NO. USS078

**REPLACEMENT LENSES & PLATES**

2" x 4-1/4" WELDING LENS			
STOCK NO.	SHADE	STOCK NO.	SHADE
ES0604	#4	ES0609	#9
ES0605	#5	ES06010	#10
ES0606	#6	ES06011	#11
ES0608	#8	ES06012	#12

ES064 2" x 4-1/4 CLEAR GLASS LENS COVER  
ES067 2" x 4-1/4 CLEAR PLASTIC LENS COVER

2" ROUND WELDING LENS	
STOCK NO.	SHADE
ES0744	#4
ES0745	#5
ES070	2" CLEAR PLASTIC LENS
ES071	2" CLEAR GLASS LENS

4-1/2" x 5-1/4" WELDING LENS			
STOCK NO.	SHADE	STOCK NO.	SHADE
ES0616	#6	ES06110	#10
ES0618	#8	ES06111	#11
ES0619	#9	ES06112	#12

4-1/2" x 5-1/4" CLEAR POLYCARB. SAFETY / COVER PLATE.

STOCK NO. USS086

**metabo**

**POWER TOOLS**

**metabo**

**DRILLS**

METABO DRILLS FEATURE PRECISION-GROUND GEARED CHUCKS, ELECTRONIC VARIABLE SPEED CONTROLS, ADJUSTABLE SIDE HANDLES, POWERFUL AMP MOTORS AND 2-SPEED GEAR BOXES, STURDY MOTOR AND GEAR HOUSINGS, AUTO-STOP BRUSHES AND HEAVY-DUTY POWER CORDS.

**3/8" CHUCK DRILL - ECONOMY MODEL**



ROBUST SPLIT HOUSING. LONG-LIFE MOTOR. VARIOSPEED FULL-WAVE ELECTRONIC SPEED CONTROL. REVERSING FEATURE. TORQUE 40 INCH LBS. 4.5 AMPS. NO-LOAD SPEED 0-2,800 RPM. STANDARD EQUIPMENT: 3/8" GEARED CHUCK, CHUCK KEY

**STOCK NO. MET00557**

**1/2" CHUCK DRILL**



ALUMINUM DIE-CAST GEAR HOUSING. REVERSING FACILITY, SLIP CLUTCH, WINDING PROTECTION GRID. TORQUE- 142 INCH LBS. 1/2" CAPACITY IN MILD STEEL, 1-9/16" CAPACITY IN SOFTWOOD. 1000/3000 RPM. 5.8 AMPS. 13-1/4" LENGTH.

**STOCK NO. MET830**

**THIS SPACE RESERVED FOR FUTURE METABO POWER TOOLS**

**1/2" ECONOMY HAMMER DRILL**



MAX SPEED CONTROLLED BY ADJUSTING DIAL. REVERSING FEATURE. AUTO-STOP CARBON BRUSHES. TORQUE 40 INCH LBS. 4.5 AMPS. NO-LOAD SPEED 0-2,800 RPM. STANDARD EQUIPMENT: GEARED CHUCK, SIDE HANDLE, DEPTH GAUGE.

**STOCK NO. MET00559**

**1/2" CHUCK HAMMER DRILL**



VARIOSPEED FULL-WAVE ELECTRONIC SPEED CONTROL. REVERSING FEATURE. AUTO-STOP CARBON BRUSHES. TORQUE 159 INCH LBS. 6.2 AMPS. NO-LOAD SPEED 1000/3000 RPM. STANDARD EQUIPMENT: GEARED CHUCK, SIDE HANDLE, DEPTH GAUGE, CARRYING CASE.

**STOCK NO. MET00760**

**1" SDS ROTARY HAMMER**



SUITABLE FOR LIGHT CHISELING WORK. PERCUSSION STOP FOR DRILLING ONLY OPERATIONS. ALUMINUM DIE-CAST GEAR HOUSING. REVERSING FACILITY. SLIP CLUTCH. AUTO-STOP CARBON BRUSHES. WINDING PROTECTION GRID. ELECTRONIC SPEED STABILIZER. TORQUE- 106 INCH LBS. 0-1000 RPM. 5.6 AMPS. 16-3/4" LENGTH.

**STOCK NO. MET00223**

**ACCESSORIES**

**CHUCKS**

**CHUCK KEY**



**STOCK NO. MET35252** (0 - 3/8" CHUCK)  
**STOCK NO. MET35250** (1/2" CHUCK)  
**STOCK NO. MET35167** (CHUCK KEY)

**THIS IS A COMPREHENSIVE CATALOG OF OUR MAJOR LINES AND SERVICES.**

**BUT IT DOES NOT SHOW ALL AVAILABLE PRODUCT LINES.**

**IF THERE IS SOMETHING YOU NEED THAT IS NOT SHOWN, WE EITHER CARRY IT OR CAN GET IT.**

**PLEASE CALL US FOR INFORMATION**

**KEY TYPE PRECISION CHUCKS AND CHUCK KEYS**

**TAPER MOUNTED CHUCKS**



STOCK NO.	CAPACITY (INCHES)	TAPERED MOUNT	JACOBS EQUIV.
LFA1A	0 - 1/4	1JT	1A
LFA2A	0 - 3/8	2JT	2A
LFA6A2A	0 - 1/2	2JT	34-02
LFA6A33	0 - 1/2	33JT	34-33
LFA34	0 - 1/2	6JT	34-06
LFA3A	1/32 - 5/8	3JT	3A
LFA601085	1/16 - 3/4	4JT	-
LFA14N	*0 - 1/2	3JT	14N
LFA18N	*1/16 - 3/4	4JT	18N

*\*SUPER CHUCK - SUPER HOLDING AND FRICTION FREE MOVEMENT FOR HEAVY-DUTY DRILLING APPLICATIONS.*

**THREAD MOUNTED CHUCKS**



STOCK NO.	CAPACITY	THREADED MOUNT	JACOBS EQUIV.
LFADC4G61	*0 - 3/8	3/8 - 24	DC4G61
LFA2BA	0 - 3/8	3/8 - 24	2BA
LFA32B	0 - 3/8	1/2 - 20	32BA
LFA33B	1/16 - 1/2	3/8 - 24	33BA
LFA33BA	1/16 - 1/2	1/2 - 20	33BA

*\*LIGHT DUTY -DESIGNED FOR HOME WORK SHOP TYPE ELECTRIC DRILL.*

**MEDIUM DUTY CHUCKS**



STOCK NO.	CAPACITY	THREADED MOUNT	JACOBS EQUIV.
LFA74K	0 - 3/8	3/8 - 24	-
LFA76K	1/16 - 1/2	3/8 - 24	-
LFA77K	1/16 - 1/2	1/2 - 20	-

**KEYLESS CHUCK**



STOCK NO.	CAPACITY	TAPERED MOUNT	JACOBS EQUIV.
LFA7120520A	0 - 3/8	3/8 - 24	-

**MORSE TAPER ARBORS**

*LFA ARBORS ARE FULLY HARDENED AND GROUND*



STOCK NO.	MORSE TAPER x	JACOBS TAPER
941102	1MT	2JT
LFA941202	2MT	2JT
LFA941203	2MT	3JT
LFA941204	2MT	4JT
LFA941206	2MT	6JT
LFA941233	2MT	33JT
LFA941302	3MT	2JT
LFA941303	3MT	3JT
LFA941304	3MT	4JT
LFA941306	3MT	6JT
LFA941333	3MT	33JT
941403	4MT	3JT
LFA941404	4MT	4JT
LFA941406	4MT	6JT
941503	5MT	3JT

**PIN VISES**



FOR HOLDING SMALL RODS, WIRE, DRILLS, TAPS, AND OTHER SMALL TOOLS. NICKEL PLATED BODY IS HOLLOW TO PERMIT HOLDING OF LONG RODS OF WIRE. TOOL STEEL COLLETS ARE HARDENED AND GRIP FIRMLY WHEN SCREW CHUCK IS TIGHTENED.

STOCK NO. **GEN94A** (0 - .055 RANGE)  
STOCK NO. **OD999** (.005 - .040 RANGE)

**MICRO ADAPTER DRILL CHUCK**



DRILLS IN A VARIETY OF WIDTHS AND SIZES CAN BE HELD IN ANY 1/8" OR 3/16" COLLET OR LARGER ADJUSTABLE DRILL CHUCK. GRIPS FIRMLY AND ACCURATELY. GREAT CONVENIENCE FOR THOSE INFREQUENT SMALL JOBS.

STOCK NO. **OD998** (.000-.040)

**CHUCK KEYS**



STOCK NO.	KEY MODEL	JACOBS EQUIV.	FOR CHUCK	PILOT SIZE MODEL
LFAT1	T1	K1	1A,1B	5/32
LFATB1	TB1	KG	DC4G61	15/64
LFAT2	T2	K2	2A,2BA	1/4
LFAT4	T4	K7	JACOBS' 7, 7-1A,7B	7/32
LFAT5	T5	K32	32B,33B, 33BA	1/4
LFAT5C	T5C	K32C	JACOBS' #3333C	1/4
LFAT6	T6	K3	3A,34,6A-33, 6A-2A,14N	5/16
LFAT6C	T6C	K3C	JACOBS' #633C,633D	5/16
LFAT13	T13	K30	8-1/2N,30, 30B,31B,31BA	15/64
LFATB13	TB13	KK	DC8K61, DC8K64	9/32
LFAT9	T9	K4	18N,9A	3/8
LFAT26	T26	K5	20N	7/16
LFATBD	TBD	B & D	ALL B & D 70-110	13/64 1/4 & 3/8

**DRILL CHUCK KEYHOLDER**



FITS ALL KEYS EXCEPT #9 AND #26

STOCK NO. **LFAKH**

THIS SPACE  
RESERVED  
FOR FUTURE  
PRODUCTS

# metabo®

## POWER TOOLS

# metabo®

### ANGLE GRINDERS



METABO "QUICK" ANGLE GRINDERS FEATURE SPINDLE LOCKS, ALUMINUM DIE-CAST GEAR HOUSING, HIGH PERFORMANCE SPIRAL BEVEL GEARS, WHEEL GUARD WITH LOCKING DEVICE, SLIP CLUTCH, AUTO-STOP CARBON BRUSHES, WINDING PROTECTION GRID.

#### 4-1/2" ANGLE GRINDER

TORQUE- 21 INCH LBS. 10,000 RPM. 8.0 AMPS. 11" LENGTH. 5/8-11" SPINDLE.  
**STOCK NO. METW8115**

#### 5" ANGLE GRINDER

TORQUE- 27 INCH LBS. 10,000 RPM. 8.5 AMPS. 12" LENGTH. 5/8-11 SPINDLE.  
**STOCK NO. MET01026**

#### 6" ANGLE GRINDER

ALSO FEATURES ELECTRONIC WINDING TEMPERATURE MONITOR WITH **LED DISPLAY**, ELECTRONIC GENTLE START FEATURE AND SPEED STABILIZER. TORQUE- 31 INCH LBS. 9000 RPM. 12 AMPS. 12" LENGTH. 5/8-11 SPND.  
**STOCK NO. MET01451**

#### 9" ANGLE GRINDER



ALSO FEATURES 3 POSITION SIDE LOCK HANDLE AND 3 POSITION REAR HANDLE FOR CUTTING/GRINDING. PLUS TOOL-FREE GUARD ADJUSTMENT AND SAFETY LOCK. TORQUE- 150 INCH LBS. 6600 RPM. 15 AMPS. 18" LENGTH.  
**STOCK NO. MET06415**

#### 9" HEAVY-DUTY ANGLE GRINDER

TORQUE- 159 INCH LBS. 6600 RPM. 18 AMPS. 18" LENGTH.  
**STOCK NO. MET06425**

### DIE GRINDERS



2" DIE GRINDER WITH 1/4" COLLET BORE. AUTO-STOP CARBON BRUSHES. TORQUE- 6 INCH LBS. 27000 RPM. 4.4 AMPS. 9" LENGTH.

**STOCK NO. MET06301**

### DIE GRINDERS



2" DIE GRINDER WITH VARIABLE SPEED. 1/4" COLLET BORE. EXTENDED SPINDLE. AUTO-STOP CARBON BRUSHES. TORQUE- 9 INCH LBS. 7000-27000 RPM. 6.2 AMPS. 13" LENGTH.

**STOCK NO. MET06303**

### ACCESSORIES

#### CARRYING CASE



STEEL CASE IS 13-3/4" L x 10" W x 5-1/8" H.

**STOCK NO. MET23999B**

#### BACK-UP PADS



STOCK NO.	DIA.	FITS BACKING NUT
<b>MET23279</b>	4-1/2	M14
<b>MET23283</b>	4-1/2	5/8-11
<b>MET23278</b>	5"	M14
<b>MET23281</b>	7"	5/8-11

#### SPANNER WRENCH



**STOCK NO. MET23934**

#### GRINDER WHEEL GUARD

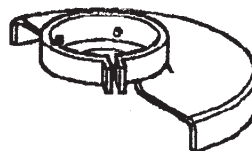

STOCK NO.	SIZE
<b>MET31602823</b>	4-1/2, 5"
<b>MET31602824</b>	6"

### VARIABLE SPEED JIG SAW WITH ORBIT



ALUMINUM DIE-CAST GEAR HOUSING. SPEED ADJUSTING DIAL. ELECTRONIC SPEED STABILIZER. 4-STAGE ORBITAL SAW-BLADE MOVEMENT. GROOVED NEEDLE-BEARING ROLLER-GUIDE. SUITABLE FOR BEVEL CUTS. ACCEPTS MOST STYLES OF JIG SAWS. AUTO-STOP CARBON BRUSHES. TORQUE- 62 INCH LBS. 6.1 AMPS. 10-1/2" LENGTH.

**STOCK NO. MET11000**

### SERVICE WITH A SMILE.



THE YOUNG BOY PROTESTED VIGOROUSLY WHEN HIS MOTHER ASKED HIM TO TAKE HIS YOUNGER SISTER ALONG FISHING. "THE LAST TIME SHE CAME," HE OBJECTED, "I DIDN'T CATCH A SINGLE FISH."  
"I'LL TALK TO HER," HIS MOTHER SAID, "AND I PROMISE THIS TIME SHE WON'T MAKE ANY NOISE."  
"IT WASN'T THE NOISE, MOM," THE BOY REPLIED. "SHE ATE ALL MY BAIT."



**HEAVY-DUTY HOLE-SHOOTER DRILLS**

**3/8" CHUCK DRILL**



TRIGGER SPEED CONTROL REVERSING. ALL METAL GEAR CASE AND DIAPHRAGM. CHUCK KEY AND RUBBER FLEX KEY HOLDER. 0-1200 RPM. 7 AMPS. 12.1" LENGTH.

STOCK NO. MILW020020

**1/2" CHUCK DRILL**



MAGNUM MODEL DRILL FEATURES EXCLUSIVE BRUSH CARTRIDGE SYSTEM FOR QUICK-CHANGE AND STORAGE. QUICK-LOCK 8' CORD. 0-850 RPM. 5.5 AMPS. 10-1/2" LENGTH.

STOCK NO. MILW02341

**1/2" REVERSING HEAVY-DUTY DRILL**



DURABLE NYLON "D" HANDLE FOR STURDY GRIP. SINGLE SPEED. 600 RPM. 7 AMPS. 14-3/4" LENGTH.

STOCK NO. MILW10011

**1/2" REVERSING SPADE DRILL**



HEAVY-DUTY ALUMINUM ALLOY HOUSING. NON-CONDUCTIVE NYLON SPADE AND SWITCH HANDLES. PIPE HANDLE REMOVABLE FOR CLOSE QUARTER DRILLING. 450 RPM. 7 AMPS. 12-1/4" LENGTH.

STOCK NO. MILW16601

**POWER TOOLS**

**HAMMER DRILLS**

**3/8" CHUCK 2-SP. REVERSING HAMMER DRILL**



COMPACT AND IDEAL FOR OVERHEAD DRILLING. TRIGGER SPEED CONTROL. IMPACT-RESISTANT, NON-CONDUCTIVE MOTOR HOUSING AND HANDLE. TWO POSITION SIDE HANDLE ADJUSTABLE DEPTH GAUGE. CAPACITY: 9/16" IN CONCRETE, 3/8" IN STEEL, 3/4" IN WOOD. 0-2500 RPM. 5.0 AMPS. 11" LENGTH.

STOCK NO. MILW53921

**1/2" CHUCK HAMMER DRILL KIT**



TRIGGER SPEED CONTROL AND QUICK-LOCK CORD. REVERSING. REMOVABLE BRUSH CARTRIDGE SYSTEM. SELF-STOPPING BRUSHES. HEAVY-DUTY INDUSTRIAL CHUCK. INCLUDES 1/2" HAMMER DRILL, STEEL TRAY, CARRYING CASE AND 4 CARBIDE-TIPPED BITS: (3/16 x 3", 1/4 x 4", 3/8 x 4" and 1/2 x 6") CAPACITY: 3/4" IN CONCRETE, 1/2" IN STEEL. 0-2500 RPM. 8.5 AMPS. 14-3/4" LENGTH.

STOCK NO. MILW538722



**8' REPLACEMENT CORD**

STOCK NO. MILW48764008

**HEAVY-DUTY DRAIN CLEANER**



QUICK, EASY RODDING OF UP TO 2" WASTELINES. HOLDS UP TO 35' OF 3/8" OR 50' OF 5/16" INNER CORE CABLE. KEYLESS CHUCK OFFERS QUICK HAND TIGHTENING AND CABLE FEED. BALL AND ROLLER BEARINGS.

STOCK NO. MILW05671



**7"/9" ANGLE GRINDER**



NON-CONDUCTIVE NYLON MOTOR HOUSING. REVERSIBLE SIDE HANDLE. SELF-STOPPING LONG LIFE BRUSH SYSTEM. SPINDLE LOCK BUTTON. URETHANE TOOL REST. 5000 RPM. 13 AMP. 17" LENGTH.

STOCK NO. MILW6072

**9" GUARD FOR GRINDING WHEELS**



STOCK NO. MILW49120340

**PORTABAND SAW KIT**



TWO-SPEED (250/200) BAND SAW WITH FRONT T-HANDLE. IDEAL FOR SAWING PVC TUBING. INCLUDES ONE 14 TOOTH BI-METAL BLADE AND CARRYING CASE. 20" LENGTH OF TOOL.

STOCK NO. MILW6226

**HEAVY-DUTY SAWZALL KIT**



VARIABLE SPEED (0-2800) WITH ADJUSTABLE PIVOT SHOE. 11 AMPS. 16" LENGTH. INCLUDES CASE.

STOCK NO. MILW650922

**HEAVY-DUTY CIRCULAR SAW**



7-1/4" 15 AMP CIRCULAR SAW. ALUMINUM SHOE. LIGHTWEIGHT. LOWER GUARD CONTOUR LIP. 9' CORD LENGTH. EXTERNAL BRUSHES. NON-CONDUCTIVE NYLON HOUSING AND HANDLE. INCLUDES HIGH-SPEED STEEL BLADE AND WRENCH.

STOCK NO. MILW6390

**POWER TOOLS**

**DEWALT**

**HEAVY-DUTY SCREWGUN**



A TORQUE-ADJUSTABLE SCREWDRIVER (WITH *VERSA-CLUTCH* FEATURE) WHICH ALLOWS YOU TO OVERRIDE THE TORQUE SETTING WHEN MATERIALS OF VARYING DENSITY ARE ENCOUNTERED. IDEAL FOR ALL STEEL FRAMING APPLICATIONS. QUICK-CHANGE 1/4" HEX DRIVE. 2500 RPM. 6.5 AMPS. MAXIMUM TORQUE 132 INCH LBS. DOUBLE GEAR REDUCTION. 11.1" LENGTH.

**STOCK NO. DEDW268**

**3/8" RIGHT ANGLE DRILL**



3/8" *SHORTY* DRILL IS LIGHTWEIGHT AND COMPACT TO ALLOW DRILLING IN THE TIGHTEST PLACES. PADDLE SWITCH. 1200 RPM. 3.7 AMPS. MAXIMUM TORQUE 100 INCH LBS. DOUBLE GEAR REDUCTION. 10-1/2" LENGTH.

**STOCK NO. DEDW160**

**HEAVY-DUTY ANGLE SANDER**



7" *WILDCAT* SANDER FEATURES SIDE HANDLE, DURABLE ALUMINUM GEAR AND MOTOR HOUSINGS AND AUTO-SHUTOFF BRUSH SYSTEM. SOFT MOUNT SPINDLE FOR WHEEL CHANGING. 6000 RPM. 15.0 AMPS. 18.5" LENGTH. CAN BE USED AS A GRINDER WITH OPTIONAL GUARD.

**STOCK NO. DEDW494**  
**STOCK NO. DEDW4707** (7" GUARD)

OUR COURTEOUS AND KNOWLEDGEABLE STAFF IS READY TO TAKE CARE OF YOUR ORDER

**DEWALT**

**1/2" DRIVE ELECTRIC IMPACT WRENCH**



REVERSIBLE WRENCH WITH 2100 RPM, 7.5 AMPS AND MAXIMUM TORQUE OF 345 FOOT LBS. 10.9" LENGTH. HEAVY-DUTY.

**STOCK NO. DEDW292**

**1-9/16 SPLINE ROTARY HAMMER KIT**



11 AMP MOTOR. ELECTRONIC VARIABLE SPEED. RUBBER GRIP HELPS REDUCE THE LEVEL OF VIBRATION FELT. REAR HANDLE MOUNT MEANS LESS BENDING OVER WHEN USING IN DOWN DRILLING APPLICATIONS. FACTORY CLUTCH HELPS REDUCE THE TOOL REACTION TO EMBEDDED STEEL WHEN BITS "LOCK-UP" WHILE IN OPERATION, PREVENTING INJURY.

**STOCK NO. DEDW530K**

**THIS CATALOG IS YOUR GUIDE TO EFFICIENT BUYING**

**Makita**

**3/8 ANGLE DRILL**



BALL AND NEEDLE BEARING FOR LONG LIFE. VARIABLE SPEED WITH REVERSE FOR EASY STARTING AND FASTENING SCREWS. PADDLE SWITCH FOR EASY ONE HAND OPERATION. COMPACT DESIGN FOR TIGHT FITS AND CLOSE QUARTER DRILLING. DOUBLE INSULATED.

**STOCK NO. MAKDA3010F**

**OUR WELL-STOCKED INVENTORY CAN SUIT ALMOST ANY APPLICATION! IF YOU DO NOT SEE THE ITEM YOU NEED, PLEASE LET US KNOW. WE'LL DO OUR VERY BEST TO LOCATE AND ACQUIRE THE ITEM FOR YOU!**



**BENCH GRINDERS**



UL LISTED MOTOR. PRE-LUBRICATED AND ENCLOSED BALL BEARINGS. CAST IRON WHEEL GUARDS AND DUST VENTS. ONE-PIECE QUICK ADJUSTING SPARK GUARDS. LARGE ADJUSTABLE EYE GUARDS. ADJUSTABLE TOOL RESTS. FINE AND COARSE WHEELS INCLUDED.

6" WHEEL. 1/2 HP. 1 PH. 115V ONLY.  
**STOCK NO. JET577101**

8" WHEEL. 1 HP. 1 PH. 115V ONLY.  
**STOCK NO. JET577102**

**BENCH GRINDER PEDESTAL STAND**



31" OVERALL HEIGHT. TOOL TRAY. COOLANT TANK. MOUNTING SURFACE- 11" L x 10" W.

**STOCK NO. JET577172**

**DRILL PRESS VISES**



CENTER SLIDE BAR. AXIAL SLEEVE AND MOVABLE JAW ARE CAST IN ONE SINGLE PIECE.

3" JAW WIDTH  
**STOCK NO. JET365523**

4" JAW WIDTH  
**STOCK NO. JET365524**

5" JAW WIDTH  
**STOCK NO. JET365525**

**INDUSTRIAL MACHINERY**

**DRILL PRESSES**

**BENCH MODELS**



HINGED METAL BELT AND PULLEY COUPLED WITH QUICK ADJUSTMENT MOTOR MOUNT FOR RAPID CHANGE OF SPINDLE SPEEDS. ROTATING, TILTING CRANK-OPERATED WORKTABLE. QUICK-RELEASE CLAMP. ON/OFF SWITCH ON DRILL PRESS HEAD. SLOTTED WORKTABLE AND BASE. ADJUSTABLE RETURN SPRING. DOUBLE-SEALED BEARINGS ON MOTOR.

5/8" CHUCK. 15" SWING. 3/4 HP. 1 PH. 115/230V. 16-SPEED. MORSE TAPER.  
**STOCK NO. JET354165**

**FLOOR MODELS**



HINGED METAL BELT AND PULLEY COUPLED WITH QUICK ADJUSTMENT MOTOR MOUNT FOR RAPID CHANGE OF SPINDLE SPEEDS. ROTATING, TILTING CRANK-OPERATED WORKTABLE. QUICK-RELEASE CLAMP. ON/OFF SWITCH ON DRILL PRESS HEAD. SLOTTED WORKTABLE AND BASE. ADJUSTABLE RETURN SPRING. DOUBLE-SEALED BEARINGS ON MOTOR. BUILT-IN WORK LAMP. (BULB NOT INCLUDED).

3/4" CHUCK. 20-1/2" SWING. 1-1/2 HP. 1 PH. 115/230V. 12-SPEED. MORSE TAPER.  
**STOCK NO. JET354170**



**HORIZONTAL/VERTICAL BANDSAWS**



BALL BEARING SUPPORTED BLADE WHEEL. ADJUSTABLE GUIDES. THREE CUTTING SPEEDS- 80, 120, 220 SFPM. 45° ANGLE VISE. SHELF BUILT INTO STAND. INCLUDES BLADE, BLADE GUARDS, VERTICAL WORKTABLE, REAR WHEELS ATTACHED TO STAND, AUTOMATIC SHUTOFF, ADJUSTABLE MATERIAL STOP. WORKTABLE SIZE 9-5/8" x 9-1/2". CAPACITY 4-1/2 x 6". 1/2 HP. 1 PH. 115-230V.

**STOCK NO. JET414458**



UL LISTED MOTOR. COMPACT MOBILE COMBINATION BANDSAW. ADJUSTABLE HYDRAULIC DOWNFEED. HEAVY CAST-IRON BED. SWIVELING VISE. ROLLER CABINET WITH BUILT-IN CHIP TRAY. AUTOMATIC SHUTOFF AFTER CUT. ADJUSTABLE ROLLER BLADE GUIDES. CAST-IRON BOW. INCLUDES VERTICAL SAW TABLE, COMPLETE COOLANT SYSTEM, BLADE GUARDS, CHIP BRUSH, ADJUSTABLE MATERIAL STOP, BI-METAL BLADE. VERTICAL WORKTABLE SIZE 9-3/8" x 10". CAPACITY 7" x 11". 3/4 HP. 1 PH. 115/230V.

**STOCK NO. JET414459**

**ADDITIONAL MODELS AND ITEMS AVAILABLE UPON REQUEST**

**BALDOR**

**INDUSTRIAL BENCH GRINDERS & BUFFERS**

**BALDOR**

**6" GRINDER**



U. L. LISTED AND C. S. A. CERTIFIED. THIS GRINDER IS SUPPLIED WITH PRESSED STEEL TOOL RESTS AND NON-EXHAUST TYPE GUARDS. TWO WHEELS 6" x 3/4" x 1/2". FURNISHED WITH GA10 EYE SHIELDS.

STOCK NO. **BAL612**

**6" GRINDER/BUFFER**



U. L. LISTED AND C. S. A. CERTIFIED. THIS GRINDER IS SUPPLIED WITH PRESSED STEEL TOOL RESTS AND NON-EXHAUST TYPE GUARDS. TWO WHEELS 6" x 3/4" x 1/2". FURNISHED WITH GA10 EYE SHIELDS.

STOCK NO. **BAL662**

**7" GRINDER**



U. L. LISTED AND C. S. A. CERTIFIED. THIS GRINDER IS SUPPLIED WITH PRESSED STEEL TOOL RESTS AND NON-EXHAUST TYPE GUARDS. TWO WHEELS 7" x 1" x 5/8". 1/2 HP. ALL UNITS SUPPLIED WITH NON-LIGHTED EYE SHIELDS.

STOCK NO. **BAL712**

ROBERT ORBEN SAYS: "MY WIFE CLAIMS I'M A BASEBALL FANATIC. SHE SAYS ALL I EVER READ ABOUT IS BASEBALL. ALL I EVER TALK ABOUT IS BASEBALL. ALL I EVER THINK ABOUT IS BASEBALL. I TOLD HER SHE'S WAY OFF BASE."

**8" GRINDER**



U. L. LISTED. TWO WHEELS 8" x 1" x 3/4". GUARDS ARE CAST IRON EXHAUST TYPE. SUPPLIED WITH CAST IRON TOOL RESTS AND GA11 EYE SHIELDS.

STOCK NO. **BAL8100W**

**GRINDER PEDESTAL**

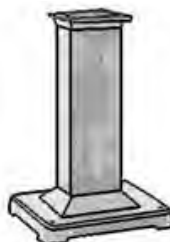

THE GA16 PEDESTAL IS FOR THE 6", 7", 8" AND 10" GRINDER, CARBIDE AND DIAMOND WHEEL GRINDERS. 1/4 HP THROUGH 1-1/2 H/P BUFFERS AND BELT GRINDERS. HEIGHT 32 7/8".

STOCK NO. **BALGA16**

**THIS SPACE RESERVED FOR FUTURE INDUSTRIAL EQUIPMENT**

WE STOCK OVER  
30,000 INVENTORY ITEMS

WE ARE CONSTANTLY ADDING  
TO OUR PRODUCT LINES TO  
SUIT YOUR APPLICATIONS.  
IF YOU DON'T SEE IT IN OUR  
CATALOG, CALL US.  
WE WILL DO EVERYTHING TO  
ACCOMMODATE YOUR NEEDS.



**HYDRAULIC BOTTLE & FLOOR JACKS, PALLET JACK AND MECHANICS CREEPER**

**HYDRAULIC BOTTLE JACKS**



INDUSTRIAL-DUTY HYDRAULIC JACKS ARE TESTED TO 150% OF RATED CAPACITIES. NOT AFFECTED BY TEMPERATURE EXTREMES. ELECTRICALLY-WELDED BASE AND CYLINDERS TO ASSURE STRENGTH AND ELIMINATE LEAKS. COMMON RELEASE VALVE ASSEMBLIES FOR QUICK-REPAIR. ALL MODELS WORK IN UPRIGHT, ANGLE OR HORIZONTAL POSITION.

STOCK NO.	CAPACITY
JET453301	2 TON
JET453303	3 TON
JET453305	5 TON
JET453308	8 TON
JET453312	12-1/2 TON
JET453322	22-1/2 TON

**\* QUALITY PRODUCTS \***  
**\* FAIR & COMPETITIVE PRICES \***  
**\* EXCELLENT SERVICE \***

**YOU CAN DEPEND ON US**

**HYDRAULIC JACK OIL**



FOR HYDRAULIC JACKS, SERVICE JACKS AND REFILLABLE-TYPE SHOCK ABSORBERS. BLENDS WITH ALL ORIGINAL FLUIDS. CONTAINS RUST AND OXIDATION INHIBITORS, ANTI-WEAR AGENTS AND FOAM INHIBITORS.

STOCK NO. APJ032 (1 QUART)

**MECHANICS CREEPER**



HEAVY-DUTY CREEPER FEATURES SOLID HARDWOOD LUMBER, HANDHOLD FOR EASY CARRYING, REINFORCED STEEL CORNERS, 3" STEEL ROLLERS, BOLTED THRU CONSTRUCTION. 40" LONG.

STOCK NO. PTW85005

**-ADDITIONAL ITEMS AVAILABLE-  
-CALL FOR DETAILS-**



**CALL US FOR ALL YOUR NEEDS  
855-785-TOOL**

**HYDRAULIC FLOOR JACK**

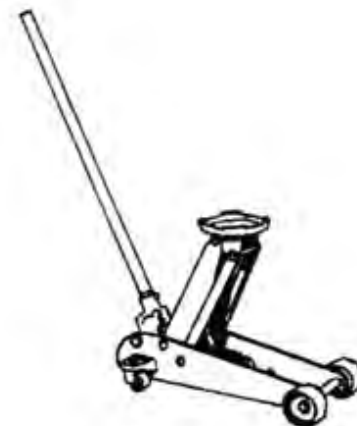

HEAVY-DUTY 3 TON CAPACITY FLOOR JACK. LIFTING RANGE 6" TO 20". 360° SWIVEL SADDLE AND SWIVEL REAR CASTERS FOR EASY POSITIONING. HEAVY-DUTY ALL-STEEL CHASSIS.

STOCK NO. PTW1617

**PALLET JACK**



EASY-TO-OPERATE PALLET JACK FOR EASY LOAD LIFTING. OPERATES FAST FOR EMERGENCIES, AND SLOW FOR FRAGILE LOADS. HAND RELEASE FUNCTIONS AS EMERGENCY BRAKE. LEAK-PROOF PUMP WITH OVERLOAD CAPACITY ASSURES MAINTENANCE-FREE SERVICE. SINGLE-POINT PUMP SERVICE: ALL VALVES ARE EASILY REPLACED IN 5 MINUTES. ONE-PIECE FORMED STEEL "C" CHANNEL TAPERED, REINFORCED FORKS. 200° PIVOT ACTION MANEUVERS IN COMPACT AREAS. TAPERED FORK ENDS AND NYLON ROLLERS PERMIT EASY ENTRY AND EXIT OF PALLETS. SELF-LUBRICATING BEARINGS AT ALL PIVOT POINTS: NO GREASING REQUIRED. LOAD CAPACITY 6000 LBS. WEIGHT 170 LBS.

STOCK NO. JET140075

**Panasonic**

**CORDLESS POWER TOOLS**

**Panasonic**

**THE BEST CORDLESS TOOLS YOU CAN PURCHASE -  
WITH A 30-DAY QUALITY SATISFACTION GUARANTEE !**

**PANASONIC REVOLITHIUM CORDLESS TOOLS**

THESE CORDLESS TOOLS USE A COBALT LITHIUM ION (LI-ION) BATTERY. THE LI-ION BATTERY PROVIDES APPROX. 2500 CHARGE/DISCHARGE CYCLES PLUS 3.0 AMP HOURS (AH) PER CHARGE. THE MOTOR ON THESE TOOLS ARE BRUSHLESS WITH AN ELECTRONIC SWITCH SYSTEM. WITH THE BRUSHLESS MOTOR AND ELECTRONIC SWITCH YOUR CORDLESS TOOL WILL LAST ABOUT TWICE AS LONG AS THE CONVENTIONAL CORDLESS TOOL.

**21.6 V CORDLESS 1/2" DRILL & DRIVER KIT**



HIGH CAPACITY 3 AH LI-ION BATTERY. HIGH POWERED 575 IN LBS. VARIABLE SPEED/ REVERSIBLE: LOW 100-400 RPM, HIGH: 350-1500 RPM. CLUTCH HAS 18 SETTINGS. 1/2" HEAVY DUTY KEYLESS CHUCK. ELECTRIC BRAKE. LED WORK LIGHT. FULL CHARGING TIME 60 MINUTES. COMES WITH AN EXTRA BATTERY PACK. COMPACT SIZE, LIGHT WEIGHT (WITH BATTERY) 5.39 LBS.

**STOCK NO. PANEY7460LN2S**

**14.4 V CORDLESS 1/2" DRILL & DRIVER KIT**



HIGH CAPACITY 3 AH LI-ION BATTERY. HIGH POWERED 390 IN LBS. VARIABLE SPEED/ REVERSIBLE: LOW 60-400 RPM, HIGH: 200-1350 RPM. CLUTCH HAS 18 SETTINGS. 1/2" HEAVY DUTY KEYLESS CHUCK. ELECTRIC BRAKE. LED WORK LIGHT. FLASH LIGHT INCLUDED. FULL CHARGING TIME 50 MINUTES. COMES WITH AN EXTRA BATTERY PACK. COMPACT SIZE, LIGHT WEIGHT (WITH BATTERY) 3.5 LBS.

**STOCK NO. PANEY7440LN2L**

**CORDLESS TOOL FACTS**

**BATTERY TECHNOLOGY INFORMATION**

TYPE	CHARGE/DISCHARGE CYCLES
NiCAD	500-600
NiMH (NICKEL METAL HYDRIDE)	1200
Li-ION (COBALT LITHIUM ION)	2500

**AMP HOURS (AH) RATINGS FOR BATTERIES**

- 1.8 - AVERAGE
- 2.0 ABOVE AVERAGE
- 2.4 - EXTENDED RUN
- 3.0 - ABOVE EXTENDED RUN
- 3.5 BEST OF ALL

AMP HOURS = RUN TIME

**3.6 V CORDLESS DRILL & DRIVER KIT**



1.5 AH LI-ION BATTERY. 2 SPEED REVERSIBLE: LOW 200 RPM, HIGH: 600 RPM. CLUTCH HAS 21 SETTINGS. 1/4" HEX QUICK CHANGE CHUCK. CAP FOR CLUTCH LOCK OUT. LED WORK LIGHT. FULL CHARGING TIME 30 MINUTES. COMES WITH AN EXTRA BATTERY PACK. COMPACT SIZE, LIGHT WEIGHT (WITH BATTERY) 1.1 LBS.

**STOCK NO. PANEY7410LA2S**

**WE ALSO STOCKS CHUCKS AND BATTERY PACKS. PLEASE CALL FOR YOUR SPECIFIC MODEL**

**21.6 V CORDLESS HAMMER DRILL & DRIVER KIT**



HIGH CAPACITY 3 AH LI-ION BATTERY. HIGH PERFORMANCE AS REGULAR DRILL MAX TORQUE 575 IN LBS. VARIABLE SPEED CONTROL/ REVERSIBLE: LOW 100-400 RPM, HIGH: 350-1500 RPM. CLUTCH HAS 18 SETTINGS. HIGH SPEED MASONRY DRILLING MAX: 1550 RPM/128,000 BPM. BLOWS RATE PER MINUTE: LOW 1800-7200 BPM, HIGH 6300-27000 BPM/ 1/2" HEAVY DUTY KEYLESS CHUCK. ELECTRIC BRAKE. LED WORK LIGHT. FULL CHARGING TIME 60 MINUTES. COMES WITH AN EXTRA BATTERY PACK. COMPACT SIZE, LIGHT WEIGHT (WITH BATTERY) 5.61 LBS.

**STOCK NO. PANEY7960LN2S**

**14.4 V CORDLESS IMPACT WRENCH KIT**



HIGH CAPACITY 3 AH LI-ION BATTERY. HIGH POWERED 1640 IN LBS. VARIABLE SPEED/ REVERSIBLE. BRUSHLESS MOTOR AND ELECTRONIC SWITCH. 3 SPEEDS. 1/2" SQUARE CHUCK. ELECTRIC BRAKE. LED WORK LIGHT. FLASH LIGHT INCLUDED. FULL CHARGING TIME 50 MINUTES. COMES WITH AN EXTRA BATTERY PACK. BELT HOOK. COMPACT SIZE, LIGHT WEIGHT (WITH BATTERY) 3.3 LBS.

**STOCK NO. PANEY7541LN2L**

A POSITIVE ATTITUDE MAY NOT SOLVE ALL YOUR PROBLEMS, BUT IT WILL ANNOY ENOUGH PEOPLE TO MAKE IT WORTH THE EFFORT.  
--HERM ALBRIGHT

**Panasonic**

CORDLESS POWER TOOLS

**Panasonic**

**THE BEST CORDLESS TOOLS YOU CAN PURCHASE -  
 WITH A 30-DAY QUALITY SATISFACTION GUARANTEE !**

**PANASONIC Ni-MH CORDLESS TOOLS**

THESE CORDLESS TOOLS USE A NICKEL-METAL HYDRIDE (Ni-MH) BATTERY. THE Ni-MH BATTERY PROVIDES APPROX. 1200 CHARGE/DISCHARGE CYCLES PLUS 3.5 AMP HOURS (AH) PER CHARGE. ENVIRONMENTALLY FRIENDLY.

**18 V CORDLESS 1/2" DRILL & DRIVER KIT**



HIGH CAPACITY 3.5 AH Ni-MH BATTERY. HIGH POWERED 442 IN. LBS. VARIABLE SPEED/ REVERSIBLE: LOW 70-430 RPM, HIGH 240-1500 RPM. CLUTCH HAS 16 SETTINGS. 1/2" HEAVY DUTY KEYLESS CHUCK. 2-SPEED GEAR BOX. CHARGING TIME 65 MINUTES. ELECTRIC BRAKE. ERGONOMIC BALANCED TOOL BODY WITH SURE GRIP SUPPORT HANDLE. COMES WITH AN EXTRA BATTERY PACK. LIGHT WEIGHT (WITH BATTERY) 5.9 LBS.

**STOCK NO. PANEE6450GQKW**

**15.6 V CORDLESS 1/2" DRILL & DRIVER KIT**



HIGH CAPACITY 3.5 AH Ni-MH BATTERY. HIGH POWERED 390 IN. LBS. VARIABLE SPEED/ REVERSIBLE: LOW 65-450 RPM, HIGH 200-1450 RPM. CLUTCH HAS 19 SETTINGS. 1/2" HEAVY DUTY KEYLESS CHUCK. 2-SPEED GEAR BOX. CHARGING TIME 55 MINUTES. ELECTRIC BRAKE. ERGONOMIC DESIGN. COMES WITH AN EXTRA BATTERY PACK. LIGHT WEIGHT (WITH BATTERY) 5.0 LBS.

**STOCK NO. PANEE6432GQKW**

JUST AS IRON RUSTS FROM DISUSE, EVEN SO DOES INACTION SPOIL THE INTELLECT.  
 --LEONARDO DA VINCI

**18 V CORDLESS 1/2" HAMMER DRILL & DRIVER KIT**



HIGH CAPACITY 3.5 AH Ni-MH BATTERY. HIGH POWERED 425 IN. LBS. VARIABLE SPEED/ REVERSIBLE: LOW 75-450 RPM, HIGH 250-1550 RPM. CLUTCH HAS 16 SETTINGS. HIGH SPEED MASONRY DRILLING: MAX 1550 RPM. BLOWS PER MINUTE: LOW 1350-8100BPM, HIGH 4500-28000 BPM. 1/2" HEAVY DUTY KEYLESS CHUCK. CHARGING TIME 65 MINUTES. ERGONOMIC BALANCED TOOL BODY WITH SURE GRIP SUPPORT HANDLE. COMES WITH AN EXTRA BATTERY PACK. LIGHT WEIGHT (WITH BATTERY) 5.9 LBS.

**STOCK NO. PANEE6950GQKW**

**15.6 V CORDLESS MULTI & DRILL DRIVER KIT**



THIS TOOL CAN DRIVE, FASTEN AND DRILL. HIGH CAPACITY 3.5 AH Ni-MH BATTERY. HIGH POWERED IMPACT MODE 1100 IN. LBS., DRILL & DRIVER MODE 286 IN. LBS. VARIABLE SPEED/ REVERSIBLE: IMPACT MODE: 0-2200 RPM, DRILL & DRIVER MODE: 0-650 RPM. CLUTCH HAS 18 SETTINGS IN DRILL & DRIVER MODE. CHARGING TIME 55 MINUTES. ELECTRIC BRAKE. COMES WITH AN EXTRA BATTERY PACK. LIGHT WEIGHT (WITH BATTERY) 4.8 LBS.

**STOCK NO. PANEE6535GQW**

**2.4 V CORDLESS DRILL & DRIVER KIT**



MAX TORQUE: 26 IN.LBS., LOW 200 RPM, HIGH 400 RPM. MULTI-STAGE CLUTCH PLUS DRILL. EASILY CONVERTS FROM STRAIGHT TO PISTOL FORM. 2 SPEED GEAR BOX. 1/4" HEX DRIVE. REVERSIBLE. GEAR LOCK MECHANISM FOR MANUAL TIGHTENING. CHARGING TIME 60 MINUTES. LIGHT WEIGHT (WITH BATTERY) .90 LBS.

**STOCK NO. PANEE503B**

**12 V CORDLESS IMPACT DRIVER KIT**



HIGH CAPACITY 3.5 AH Ni-MH BATTERY. HIGH POWERED 1060 IN. LBS. VARIABLE SPEED CONTROL/REVERSIBLE. DIGITAL CLUTCH WITH AUTO SHUT OFF. 3 SPEED. CHARGING TIME 55 MINUTES. ERGONOMIC DESIGN. LED WORK LIGHT. BELT HOOK. COMES WITH AN EXTRA BATTERY PACK. LIGHT WEIGHT (WITH BATTERY) 4.1 LBS.

**STOCK NO. PANEE7202GQW**

**12 V CORDLESS IMPACT DRIVER KIT**



HIGH CAPACITY 3.5 AH Ni-MH BATTERY. HIGH POWERED 1100 IN. LBS. 0-2600 RPM. VARIABLE SPEED CONTROL/REVERSIBLE. CHARGING TIME 45 MINUTES. ELECTRIC BRAKE. ERGONOMIC DESIGN. COMES WITH AN EXTRA BATTERY PACK. LIGHT WEIGHT (WITH BATTERY) 3.9 LBS.

**STOCK NO. PANEE7206GQW**

**18 V CORDLESS RECIPROCATING SAW COMBO KIT**



THIS KIT COMES WITH A 18V RECIPROCATING SAW (EY3544) PLUS A STANDARD RECIPROCATING SAW BLADE. AN 18V DRILL AND DRIVER (EY6450). ONE CHARGER FOR THE Ni-MH BATTERY PACK. 2 HIGH CAPACITY 3.5 AH Ni-MH BATTERY PACKS. ALSO A HEAVY DUTY CARRYING CASE.

**STOCK NO. PANEEC150GQKW**

**PORTER+CABLE**

*Innovation that works.*

**BELT SANDER**



4" x 24" SANDER FEATURES 12 AMPS AND 1500 BELT SPEED. BELT AND GEAR DRIVE. BELT TRACKING KNOB AND QUICK-RELEASE BELT-CHANGE LEVER. 14" LENGTH.

**STOCK NO. PC363**

**CUT-OFF MACHINE**



14" CUT-OFF MACHINE FEATURES 15 AMPS AND 3,900 RPM. 5" PIPE CUTTING CAPACITY. ARM LOCKS DOWN FOR EASY PORTABILITY. QUICK-RELEASE VISE SWIVELS 45°. SPINDLE LOCK. 15-3/4" HEIGHT. 10-1/2" WIDTH.

**STOCK NO. MILW617620**

**BOSCH 4-1/2" ANGLE GRINDER**



11,000 RPM. 6.0 AMPS. 5/8-11 SPINDLE. SPINDLE LOCK FOR EASY WHEEL CHANGE.

**STOCK NO. BOSCH1347A**

**ANY QUESTIONS ABOUT ANYTHING YOU SEE HERE, JUST GIVE US A CALL OR STOP ON BY.**

**POWER TOOLS**

**14" DRY CUTTER**



NEWLY DESIGNED D-HANDLE. POWERFUL 15A DOUBLE INSULATED MOTOR. THREE DEPTH SETTING ADJUSTMENTS FOR INCREASED CUTTING CAPACITY. INCLUDES A PATENTED CARBIDE TIPPED SAW BLADE. PRODUCES RAZOR SHARP CUTS IN MOST METALS WITHOUT POST MANUAL DEBURRING & LUBRICANTS. QUICK RELEASE VISE FOR MAXIMUM EFFICIENCY. CONVENIENT DEBRIS COLLECTION BOX FOR EASY CLEAN UP.

**STOCK NO. JEPJ9435**

**14" 72T CARBIDE TIPPED SAW BLADE**

PRODUCES RAZOR SHARP CUTS IN MOST METALS WITHOUT POST MANUAL DEBURRING AND LUBRICANTS.

**STOCK NO. ALFRS355STP**

*ASSISTANCE IS A*



*PHONE CALL AWAY.*

**CALL US FOR ALL YOUR NEEDS  
855-785-TOOL**

**JEPSON**  
*Tool Power*

**7-1/2" HAND DRY CUTTER**



2-5/8" CUTTING DEPTH APPLICATION. ERGONOMICALLY DESIGNED FOR BETTER STABILITY & HANDLING. MAGNESIUM GEAR HOUSING FOR LIGHTWEIGHT & STRENGTH. LOCK-OFF SWITCH WITH ELECTRIC BRAKE MECHANISM FOR ADDED SAFETY. NEWLY DESIGNED "CERMET" TIPPED SAW BLADE FOR OPTIMAL PERFORMANCE. CONVENIENT CHIP COLLECTOR AND WINDOW INDICATOR FOR EASY CLEAN-UPS. ALL BALL BEARING CONSTRUCTION. EQUIPPED WITH ONE 7-1/2" x 40T SAW BLADE. SPINDLE LOCK FOR EASY CHANGE OF BLADE. DRY CUTTER SAW BLADE CAN BE RE-SHARPENED UP TO 2 TIMES. LIGHTWEIGHT FOR USE ON JOB-SITE.

**STOCK NO. JEPJ8219**

**7-1/2" CERMET TIPPED SAW BLADE**

THE CUTTING LIFE OF A CERMET TIPPED BLADE LASTS UP TO 2 TIMES COMPARED TO A CARBIDE TIPPED BLADE. REDUCES HEAT, SPARKS, NOISE, AND VIBRATION TO PROVIDE A CLEAN "BURR FREE" CUT (NO POST PREP WORK REQUIRED).

**STOCK NO. JEP1412040**

NOT SURE WHAT TOOL IS RIGHT FOR YOUR NEEDS?

LET THE PRO'S HELP POINT YOU

IN THE RIGHT DIRECTION.



**DRILLS**

**3/8" DRILL - NON-REVERSIBLE**



POSITIVE ACTION TRIGGER CONTROLS SPEED. FOR DRILLING, COUNTER SINKING AND WIRE BRUSHING. CHUCK CAPACITY: 3/8". RPM: 2,600. WEIGHT: 4LB. LENGTH: 7". AIR INLET: 1/4".

**STOCK NO. AT3007**

**1/2" DRILL - NON-REVERSIBLE**



POSITIVE ACTION TRIGGER CONTROLS SPEED. FOR DRILLING, COUNTER SINKING AND WIRE BRUSHING. CHUCK CAPACITY: 1/2". AIR INLET: 1/4". RPM: 500. WEIGHT: 4 LB. LENGTH: 7".

**STOCK NO. AT7105**

**3/8" REVERSING DRILL**



POSITIVE ACTION TRIGGER CONTROLS SPEED. FOR DRILLING, COUNTER SINKING AND WIRE BRUSHING. CHUCK CAPACITY: 3/8". RPM: 1,800. WEIGHT: 3LB. LENGTH: 7". AIR INLET: 1/4".

**STOCK NO. AT3002A**

**ADDITIONAL  
 AIR TOOL MODELS  
 AVAILABLE  
 UPON REQUEST.  
 CALL US  
 FOR ALL  
 YOUR NEEDS**

**AIR TOOLS**

**IMPACT WRENCHES**

**3/8" GENERAL DUTY**



TWIN HAMMER DESIGN. STEEL CLUTCH HOUSING PROTECTS HAMMER MECHANISM. FOR GENERAL AUTOMOTIVE REPAIR, BODY SHOP, FRONT END; GENERAL INDUSTRIAL USE. DRIVE SIZE: 3/8". RPM: 10,000. WORKING TORQUE RANGE: 50-90 FT-LB. MAX TORQUE: 200 FT-LB. WEIGHT: 3.3LB. LENGTH: 6" AIR INLET: 1/4"

LB. MAX TORQUE: 200 FT-LB. WEIGHT: 3.3LB. LENGTH: 6" AIR INLET: 1/4"

**STOCK NO. AT2150**

**3/8" HEAVY-DUTY**



COMPOSITE HOUSING. TWIN HAMMER DESIGN. LARGE EASY TO USE FORWARD-REVERSE SWITCH. SWIVEL AIR INLET FITTING. BOTTOM GREASE FITTING. DRIVE SIZE: 3/8". RPM: 10,400. WORKING TORQUE RANGE: 131-189 FT-LB. MAX TORQUE: 665 FT-LB. WEIGHT: 2.7 LB. LENGTH: 6.5". AIR INLET: 1/4"

LB. WEIGHT: 2.7 LB. LENGTH: 6.5". AIR INLET: 1/4"

**STOCK NO. ATRC2163**

**3/8" BUTTERFLY IMPACT WRENCH**



SINGLE HAMMER DESIGN. AIR INLET SWIVELS 360 DEGREES FOR EASY MANEUVERING. BUTTERFLY THROTTLE ALLOWS ONE HAND DIRECTIONAL CHANGES. FOR BENCH WORK, CARBURETORS, IGNITIONS, BODY PANELS, TRANSMISSIONS, FENDER STRUTS, OIL PANS AND SMALL ENGINE WORK. WORKING TORQUE: 60 FT-LB. DRIVE SIZE: 3/8". RPM: 10,000. WORKING TORQUE RANGE: 20-60FT-LB. MAX TORQUE: 100 FT-LB. WEIGHT 2.8 LB. LENGTH: 6.4". AIR INLET: 1/4"

**STOCK NO: ATRC2100**

**SERVICE  
 YOU  
 CAN  
 DEPEND  
 ON!**



**1/2" HEAVY-DUTY**



COMPOSITE HOUSING. TWIN HAMMER DESIGN. LARGE EASY TO USE FORWARD-REVERSE SWITCH. BOTTOM GREASE FITTING. SWIVEL AIR INLET FITTING. DRIVE SIZE: 1/2". RPM: 7,800. WORKING TORQUE RANGE: 210-295 FT-LB. MAX TORQUE: 333 FT-LB. WEIGHT: 4.5LB. LENGTH: 8.2". AIR INLET: 1/4".

**STOCK NO. AT2263**

**1/2" IMPACT WRENCH**



PIN CLUTCH DESIGN. HANDLE EXHAUST DIRECTS AIR AWAY. FOR AUTOMOTIVE REPAIR, BODY SHOP, FRONT END, GENERAL INDUSTRIAL USE. DRIVE SIZE: 1/2". RPM: 7,800. TORQUE RANGE: 185-275 FT-LB. MAX TORQUE: 475 FT-LB. WEIGHT: 5.3LB. LENGTH: 7.3". AIR INLET: 1/4".

**STOCK NO. AT2215**

**3/4" HEAVY-DUTY**



COMPOSITE HOUSING. TWIN HAMMER DESIGN. LARGE, EASY-TO-USE FORWARD-REVERSE SWITCH. BOTTOM GREASE FITTING. SWIVEL AIR FITTING. DRIVE SIZE: 3/4". RPM: 5500. WORKING TORQUE RANGE: 500-885 FT-LB. MAX TORQUE: 1,125 FT-LB. WEIGHT: 7.8 LB. LENGTH: 9.4". AIR INLET: 3/8"

**STOCK NO. AT2375EC**

**3/4" GENERAL DUTY**



SINGLE HAMMER DESIGN. BUILT-IN REGULATOR. AVAILABLE WITH EXTENDED ANVIL. RUBBER HOUSING COMPONENTS FOR PROTECTION. DRIVE SIZE: 3/4". RPM: 5,000. WORKING TORQUE RANGE: 145-550FT-LB. MAX TORQUE: 600 FT-LB. WEIGHT: 10.5 LB. LENGTH: 9.5". AIR INLET: 3/8"

**STOCK NO. AT1015**

## ST. LOUIS PNEUMATIC

## AIR TOOLS

**SANDERS****3' - 5" HIGH SPEED**

BUILT IN REGULATOR TO CONTROL SPEED. LIGHTWEIGHT, COMPACT DESIGN. INCLUDES 3" & 5" BACKING PAD. FOR PAINT REMOVAL, SHAPING FILLER PATCHES, WELD SMOOTHING AND RUST REMOVAL. NOT FOR USE WITH GRINDING WHEELS. RPM: 18,000. SPINDLE: 3/8". WEIGHT: 2.4LB LENGTH: 4.6". AIR INLET: 1/4"

STOCK NO. AT6003A

STOCK NO. FP5404 (4-1/2" FIBER BACK-UP PAD)

**DUAL ACTION SANDER**

DUAL ACTION. BUILT-IN REGULATOR. LIGHTWEIGHT ALL ALUMINUM BODY CONSTRUCTION. INSULATED GRIP. FOR TOUCH-UP, FEATHER-EDGING, SANDING, AND PRE-PAINT PREPARATION. PAD SIZE: 6". RPM: 10,000. ORBIT: 5/16" PATTERN. WEIGHT: 4.6LB. LENGTH: 12". AIR INLET: 1/4".

STOCK NO. AT6005

STOCK NO. FP5416 (6" REPLACEMENT PAD)

**JITTERBUG SANDER**

DURABLE CONSTRUCTION. FOR WET AND DRY SANDING. FOR WOOD, METAL OR PLASTIC FINISHING, AND FIBERGLASS. PAD SIZE: 3.5 X 7.75". RPM: 8,000. WEIGHT: 4.3LB. LENGTH: 8". AIR INLET: 1/4".

STOCK NO. AT6009

**TWO PISTON BOARD SANDER**

DUAL PISTONS PROVIDE EFFICIENT POWER AND PREVENTS STALLING. TWO HANDLE DESIGN. FEATHERS WITH EASE AND SMOOTHNESS. FOR ALL TYPES OF SURFACE PREPARATION AND RAPID REMOVAL OF MATERIAL FROM LARGE AREAS. PAD SIZE: 2.5 X 15.75". RPM: 3,300. APPROX. POWER: 0.75 HP. WEIGHT: 6.5LB. LENGTH: 16". AIR INLET: 1/4".

STOCK NO. AT6017

**DIE GRINDERS****1/4" EXTENDED SPINDLE**

EXTENDED LENGTH FOR HARD TO REACH AREAS. ALL BALLBEARING CONSTRUCTION. RIB TEXTURED HANDLE PROVIDES FIRM GRIP. FOR BLENDING, SMOOTHING, AND PORTING. COLLET SIZE: 1/4". RPM: 22,000. THROTTLE TYPE: SAFETY LEVER. EXHAUST: REAR. WEIGHT: 2.75LB. LENGTH: 13". AIR INLET: 1/4".

STOCK NO. AT5002X

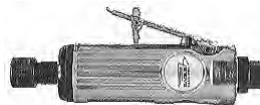
**1/4" DIE GRINDER**

ALL BALL BEARING CONSTRUCTION. COMPACT AND LIGHTWEIGHT. RIB TEXTURED HANDLE PROVIDES FIRM GRIP. FOR BLENDING, SMOOTHING AND PORTING. COLLET SIZE: 1/4". RPM: 22,000. THROTTLE TYPE: SAFETY LEVER. EXHAUST: REAR. WEIGHT: 1.2LB. LENGTH: 6.9". AIR INLET: 1/4".

STOCK NO. AT5002A

**1/4" HEAVY-DUTY DIE GRINDER**

REAR EXHAUST. 20,000 RPM. SAFETY THROTTLE LEVER. 6-3/4" LENGTH.

STOCK NO. SLP83025 (MADE IN USA)

**1/4" ANGLE DIE GRINDER**

COMPACT LIGHTWEIGHT DESIGN. BALL BEARING CONSTRUCTION. FOR SANDING, DEBURRING, PORTING, AND POLISHING. RIGHT ANGLE PROVIDES EASY ACCESS. REAR EXHAUST. COLLET SIZE: 1/4". RPM: 20,000. THROTTLE TYPE: SAFETY LEVER. WEIGHT: 1 LB. LENGTH: 6.3" AIR INLET: 1/4"

STOCK NO. AT5003B

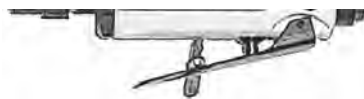
**1/4" MINI-DIE GRINDER**

COMPACT FOR GENERAL PURPOSE APPLICATIONS. REAR EXHAUST. 25,000 RPM. 5.8 INCH LENGTH.

STOCK NO. SLP83125 (MADE IN USA)

**1/4" MINI-ANGLE DIE GRINDER**

COMPACT FOR GENERAL PURPOSE APPLICATIONS. REAR EXHAUST. 19,000 RPM. 6.0 INCH LENGTH.

STOCK NO. SLP83150 (MADE IN USA)

**HORIZONTAL CUT-OFF GRINDERS**

REAR EXHAUST DIRECTS EXHAUST AIR AWAY. LOCK-OFF THROTTLE PREVENTS ACCIDENTAL START-UPS. FOR CUTTING MUFFLER CLAMPS, USE IN BODY SHOPS. RPM: 24,000. WEIGHT: 2 LB. LENGTH: 8". AIR INLET: 1/4".

STOCK NO. ATRC7191

**1/4" DIE GRINDER COMPOSITE BODY**

LIGHTWEIGHT AND DURABLE. ERGONOMIC COMPOSITE HOUSING WITH A SOFT GRIP. FOR BLENDING, SMOOTHING AND SANDING. RPM: 22,000. WEIGHT: 1.3 LB. LENGTH: 8". AIR INLET: 1/4".

STOCK NO. AT5200EC

**1/4" 90° ANGLE DIE GRINDER COMPOSITE BODY**

LIGHTWEIGHT AND DURABLE. ERGONOMIC COMPOSITE HOUSING WITH A SOFT GRIP. RIGHT ANGLE PROVIDES EASY ACCESS. FOR SANDING, POLISHING, DEBURRING AND PORTING. RPM: 20,000. WEIGHT: 1.1 LB. LENGTH: 6.258". AIR INLET: 1/4".

STOCK NO. AT5202EC

**BELT SANDERS****1/2" X 24" BELT SANDER**

BEST FOR SANDING CONFINED AREAS CURVED SURFACES. ADJUSTABLE SANDING BELT ROTATES TO ALLOW EASY HANDLING. QUICK CHANGE BELT SYSTEM. BELT SIZE: 1/2" X 24". RPM: 16,000. WEIGHT: 1.7LB. LENGTH: 23.5". AIR INLET: 1/4".

STOCK NO. AT6115

**3/4" X 20 1/2" BELT SANDER**

BEST FOR SANDING CONFINED AREAS CURVED SURFACES. ADJUSTABLE SANDING BELT ROTATES TO ALLOW EASY HANDLING. QUICK CHANGE BELT SYSTEM. BELT SIZE: 3/4" X 20 1/2". RPM: 16,000. WEIGHT: 3.1LB. LENGTH: 11.9". AIR INLET: 1/4".

STOCK NO. AT6116

ST. LOUIS PNEUMATIC

FLORIDA PNEUMATIC

**AIR TOOLS**



**RATCHETS**

**3/8" DRIVE HEAVY-DUTY**

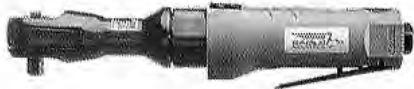

SOFT COMPOSITE GRIP FOR INCREASED OPERATOR COMFORT. BUILT-IN GREASE FITTING PROVIDES ACCESS TO CRITICAL COMPONENTS. FOR WATER PUMPS, RADIATORS, SPARK PLUGS, BODY SHOPS. DRIVE SIZE: 3/8". RPM: 160. TORQUE OUTPUT: 30 FT-LB. WEIGHT: 2.5 LB. LENGTH: 10.5". AIR INLET: 1/4"

STOCK NO. AT3205

**1/2" DRIVE HEAVY-DUTY**



EXCELLENT FOR EXTENDED USAGE. IMPROVED GEAR HEAD EXTENDS LIFE. POWER FOR TOUGH JOBS. DRIVE SIZE: 1/2". RPM: 150. TORQUE OUTPUT: 55 FT-LB. WEIGHT: 3.1 LB. LENGTH 14.5". AIR INLET: 1/4".

STOCK NO. AT1005

**MINI-OILER**



AUTOMATIC IN-LINE OILER. SOLID BRASS. 1/4" NPT THREADS. SEE-THROUGH RESERVOIR SHOWS WHEN OIL IS NEEDED. HELPS PROTECT AIR TOOLS FROM RUST AND CORROSION.

STOCK NO. JETJG301

**ACCESSORIES**

**.401 SHANK PNEUMATIC RETAINING SPRING**



STOCK NO. MAY31988 (QUICK CHANGE)

**.401 BEEHIVE RETAINING SPRING**



STOCK NO. AJT895IR

ADDITIONAL ITEMS AVAILABLE UPON REQUEST

**AIR HAMMERS**

**HEAVY-DUTY HAMMER KIT**



INCLUDES FP1010 AIR HAMMER AND DURABLE MOLDED PLASTIC BOX. CHISELS NOT INCLUDED. .401 SHANK OPENING. 2,600 BLOWS PER MINUTE. 7-1/2" TOOL LENGTH.

STOCK NO. FP1010K

**AIR HAMMER**



ECONOMICAL FOR FAST CUTTING ACTION. FOR MUFFLER AND PIPE REMOVAL, BODY SHOP WORK, SHOCK WORK, SCRAPING RUST, LIGHT FRONT END WORK. FOR EXHAUST SYSTEM, PANEL CUTTING, GENERAL REPAIR WORK. INCLUDES 6" CHISEL WITH 1-3/8" ANGLED BLADE. CHISEL DIAMETER: 0.401". BPM: 3,500. WEIGHT: 3.8 LB. LENGTH: 6.8". AIR INLET: 1/4".

STOCK NO. AT4001

**AIR HAMMER HEAVY-DUTY**



HEAVY DUTY SPRING RETAINER. LONG LASTING. FOR FRONT END, EXHAUST, FRAME AND BODY WORK. FOR USE WITH: CHISEL. DIAMETER: 0.401". BPM: 2,100. WEIGHT: 4.3LB.

LENGTH: 8.5". AIR INLET: 1/4"

STOCK NO. AT4178

**.401 SHANK PNEUMATIC CHISELS  
-1/2" WIDE COLD CHISEL**



STOCK NO. FP5220

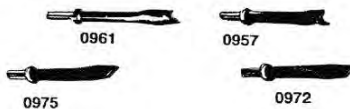

STOCK NO. MAY31956 (PANEL CUTTER)  
STOCK NO. MAY31957 (PANEL CUTTER)  
STOCK NO. MAY31972 (6" COLD CHISEL)  
STOCK NO. MAY31975 (RIVET AND BOLT CUTTER)

**.401 SHANK PNEUMATIC CHISELS**

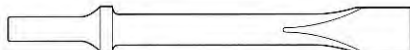

STOCK NO. AJT910 3/4" X 7" FLAT CHISEL  
STOCK NO. AJT91018 3/4" X 18" FLAT CHISEL  
STOCK NO. GPCH102 3/4" X 7" FLAT CHISEL

**HEAVY-DUTY AIR HAMMER KIT WITH CHISELS**



INCLUDES FP1010 AIR HAMMER (SEE PICTURE AT LEFT), MUFFLER REMOVAL TOOL, RIPPING TOOL & CUT-OFF, MUFFLER SPLITTER AND WIDE COLD CHISEL. DURABLE MOLDED PLASTIC BOX.

STOCK NO. FP1010K3

**NEEDLE SCALER**



HARDENED BARRELS AND STRICT TOLERANCES FOR MAXIMUM LIFE. FOR FOUNDRIES FABRICATION SHOPS, AND CONSTRUCTION. FOR USE WITH NEEDLES.

NEEDLE DIAMETER: 18@3mm EA. BPM: 4,600. WEIGHT: 6.2LB. LENGTH: 18". AIR INLET: 1/4".

STOCK NO. AT4005

**MINI NEEDLE SCALER**



STRAIGHT HANDLE FOR HARD TO REACH AREAS. 12 PIECE 3MM NEEDLE SET INCLUDED. FOR RUST REMOVAL, WELD SLAG, AND OLD PAINT. NEEDLE DIAMETER: 3MM. BORE 1". BPM: 4,000. WEIGHT: 2.8 LB. LENGTH: 11.5" AIR INLET: 1/4".

STOCK NO. AT4615

**FLUX CHIPPER**



HARDENED BARRELS AND STRICT TOLERANCES FOR MAXIMUM LIFE. FOR FOUNDRIES, FABRICATION SHOPS, AND CONSTRUCTION. FOR USE WITH: CHISEL. CHISEL DIAMETER: 0.401". BPM: 4,600. WEIGHT: 5.8 LB. LENGTH: 9.8" AIR INLET: 1/4".

STOCK NO. AT4004

**FLUX CHIPPER ACCESSORIES**

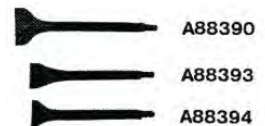

STOCK NO. UTA88392 (3/4" BLADE CHISEL)\*  
STOCK NO. UTA88390 (2" BLADE CHISEL)\*  
STOCK NO. UTA88393 (1-3/8" BLADE CHISEL)\*  
STOCK NO. UTA88394 (1-3/8" ANGLE-BLADE CHISEL)\*

\*"CLECO" STYLE SHANK

### FRAMING AND JOIST HANGER NAILERS

#### CLIPPED HEAD NAILERS

CLIPPED HEAD FRAMING NAILER FOR FRAMING, TRUSS BUILDING, SUBFLOORING, DECKING, SHEATHING, FENCING, PALLET AND CRATE ASSEMBLY.



RUGGED INTERNAL ENGINE DESIGN. BUILT IN RAFTER HANGER. THUMBWHEEL DEPTH-OF-DRIVE. IMPROVED COMFORT GRIP. AGGRESSIVE TOENAIL SAFETY. SHANK DIMENSIONS .113 - .148. SMOOTH 2" - 3-1/2". RING 2" - 3". SCREW 3". TOOL WEIGHT 8 LBS.

**STOCK NO. SENFRAMEPRO701XP**  
SEE LIST #1 FOR FASTENERS.



RUGGED ALUMINUM HOUSING STANDS UP TO THE DEMANDS OF THE JOB IN ANY KIND OF WEATHER. DEPTH-OF-DRIVE ADJUSTMENT ON THE TOOL RATHER THAN AT THE COMPRESSOR SAVES TIME AND ENERGY. RULER ON MAGAZINE - CAPABLE OF MEASURING 16" ON CENTER FOR WALL STUDS. TOENAIL FITS BETWEEN JOIST AND STUDS. SHANK DIMENSIONS .113 - .131. TOOL WEIGHT 8.4 LBS.

**STOCK NO. PAS501000**  
SEE LIST #1 FOR FASTENERS.



TWO NAILERS IN ONE: INCLUDES TWO QUICK CHANGE NOSEPIECES TO CONVERT TOOL TO EITHER FRAMING OR METAL CONNECTOR APPLICATIONS. LIGHTWEIGHT MAGNESIUM DESIGN FOR ADDED DURABILITY. INCLUDES FACTORY INSTALLED SEQUENTIAL TRIGGER AND EXCLUSIVE SMART TRIGGER. PATENTED PUSH BUTTON ADJUSTABLE DEPTH GUIDE SETS NAIL TO DESIRED DEPTHS. SHANK DIMENSIONS .131 - .148. SMOOTH 2" - 3-1/2". RING 2" - 3-1/4". SCREW 2-1/2" - 3-1/2". TOOL WEIGHT 8.1 LBS.

**STOCK NO. BOSF21PL**  
SEE LIST #2 FOR FASTENERS.

#### CORDLESS FRAMING NAILER



THE CONVENIENCE AND FREEDOM OF NO HOSES OR COMPRESSORS. ALLOWS YOU TO MOVE FREELY THROUGHOUT THE JOB SITE. FITS BETWEEN 16" O.C. JOISTS, STUDS AND TRUSSES. WORK COMFORTABLY IN CRAMPED, HARD-TO-REACH AREAS. REINFORCED DURABLE HOUSING COMES WITH A FIVE YEAR WARRANTY. LOCKS OUT TOOL AT FOUR NAILS TO PREVENT BLANK FIRING AND MINIMIZE WOOD DAMAGE. TOOL-FREE DEPTH OF DRIVE ADJUSTMENT, NO WRENCHES NEEDED. DUAL POSITION UTILITY HOOK. SHANK DIMENSIONS: .113 - .131. TOOL WEIGHT 7.4 LBS.

**STOCK NO. PAS900420**  
SEE LIST #1 FOR FASTENERS.

#### JOIST HANGER NAILERS



JOIST HANGER NAILER FOR JOIST HANGERS, FOUNDATION ANCHORS, SEISMIC AND HURRICANE STRAPS AND TIES, POST CAPS AND BASES AND OTHER METAL FRAMING HARDWARE.

SIMPLE AND FAST OPERATION. SMALL SIZE FOR ACCESS AND MANEUVERABILITY. NAIL POINT PROTRUDES SO NAILS GO IN THE HOLE EVERY TIME. DURABLE COMFORT GRIP REDUCES WORKER FATIGUE. BELT HOOK INCLUDED. INCLUDES CASE, FITTING, WRENCHES, AND OIL. SHANK DIMENSION .131, .148. TOOL WEIGHT 4.4 LBS.

**STOCK NO. SENHN150**  
SEE LIST #3 FOR FASTENERS.



AT LEAST 3 TIMES FASTER THAN HAND NAILING. ADJUSTABLE DEPTH-OF-DRIVE ENSURES NAIL DRIVES FLUSH WITH HARDWARE. PROBE ACCURATELY LOCATES METAL HARDWARE HOLE AND GUIDES THE FASTENER AS IT IS DRIVEN. SMART LEVER AUTOMATICALLY ADJUSTS TO NAIL LENGTH. OVERMOLDED COMFORT GRIP PROVIDES GREATER COMFORT IN ALL TYPES OF WEATHER. SHANK DIMENSIONS .131, .148, .162. TOOL WEIGHT 8.5 LBS.

**STOCK NO. PAS500855**  
SEE LIST #3 FOR FASTENERS.



TWO NAILERS IN ONE: INCLUDES TWO QUICK CHANGE NOSEPIECES TO CONVERT TOOL TO EITHER FRAMING OR METAL CONNECTOR APPLICATIONS. LIGHTWEIGHT MAGNESIUM DESIGN FOR ADDED DURABILITY. INCLUDES FACTORY INSTALLED SEQUENTIAL TRIGGER AND EXCLUSIVE SMART TRIGGER. PATENTED PUSH BUTTON ADJUSTABLE DEPTH GUIDE SETS NAIL TO DESIRED DEPTHS. SHANK DIMENSIONS .131 - .148. SMOOTH 2" - 3-1/2". RING 2" - 3-1/4". SCREW 2-1/2" - 3-1/2". TOOL WEIGHT 8.1 LBS.

**STOCK NO. BOSF21PL**  
SEE LIST #3 FOR FASTENERS.

**FASTENER LISTS ARE LOCATED AFTER STAPLERS**

## DOES YOUR NAILER NEED SERVICE??

## WE SERVICE ALL MAJOR BRANDS.



**BRAD FINISH NAILERS - 18 GAUGE**

**BRAD FINISH NAILERS**

18 GAUGE BRAD FINISH NAILER FOR MOLDING AND DECORATIVE TRIM, FURNITURE TRIM, WINDOW BEADING, BLIND PINNING OF UPHOLSTERED AND TRIM PANELS, RATTAN, SCRIBE MOLDING, CABINETS, DRAWERS AND PICTURE FRAME ASSEMBLY.



MANEUVERABLE AND LIGHTWEIGHT. NEVER LUBE DESIGN MEANS NO TOOL LUBRICATION TO STAIN FINE WOODS. EASY TO MAINTAIN AND SERVICE, ONLY TWO MOVEABLE O-RINGS FOR VIRTUALLY TROUBLE-FREE UPKEEP. TOOL WEIGHT 2.3 LBS.

**STOCK NO. SENSLP20XP**  
SEE LIST #4 FOR FASTENERS.



RUGGED INTERNAL ENGINE DESIGN. ADJUSTABLE DEPTH-OF-DRIVE, EXHAUST. LEFT OF RIGHT HAND ADJUSTABLE BELT HOOK. NO-MAR PAD, OVERMOLD COMFORT GRIP, OVERMOLD TRIGGER PAD. NEVER LUBE IS NO LUBRICATION REQUIRED. ON-TOOL POWER ADJUSTMENT, WITH WRENCHES ON TOOL FOR FAST ADJUSTMENTS. TOOL WEIGHT 2.7 LBS.

**STOCK NO. SENFINISHPROX**  
SEE LIST #4 FOR FASTENERS.



ADJUSTABLE DEPTH-OF-DRIVE. 2 IN 1 DESIGN ALLOWS FOR STAPLING AND NAILING IN A SINGLE TOOL. REAR EXHAUST. BELT HOOKS. NO-MAR PAD AND COMFORT TOOL GRIP. LOW LOAD BRAD INDICATOR. INCLUDES CASE, FITTING, OIL, AND HEX WRENCH. TOOL WEIGHT 2.75 LBS.

**STOCK NO. SENFINISHPRO2IN1**  
SEE LIST #4 FOR FASTENERS.



DEPTH -OF-DRIVE ADJUSTMENT CONTROLS NAIL SETTING DEPTH. SLENDER, LONG NOSE DESIGN HAS EASY ACCESS TO TIGHT SPOTS AND PERMITS PRECISE PLACEMENT OF FASTENER. CUSHIONED RUBBER GRIP PROVIDES GREATER COMFORT AND LESS FATIGUE. NO-MAR TIP. HIGH-IMPACT POLYMER HOUSING IS LIGHTWEIGHT AND DURABLE. TOOL WEIGHT 2.1 LBS.

**STOCK NO. PAS500959**  
SEE LIST #4 FOR FASTENERS.

**CORDLESS BRAD NAILER**



ADJUSTABLE WORK CONTACT ELEMENT PROVIDES CONTROL OF NAIL SETTING DEPTH. QUICK CLEAR NOSE SHOULD NAIL JAM OCCUR. LIGHTWEIGHT AND WELL-BALANCED. DEPTH-OF-DRIVE ADJUSTMENT. NARROW NO-MAR TIP PROVIDES FOR EASY ACCESS TO CONFINED AREAS AND PERMITS PRECISE PLACEMENT OF FASTENERS. TOOL WEIGHT 4.9 LBS. (WITH BATTERY)

**STOCK NO. PAS901000**  
SEE LIST #4 FOR FASTENERS.

**FASTENER LISTS ARE LOCATED  
AFTER STAPLERS**

THINKING IS THE HARDEST WORK THERE IS, WHICH IS PROBABLY THE REASON SO FEW ENGAGE IN IT.

--HENRY FORD

**DID  
YOU  
KNOW  
THAT WE  
SERVICE  
ALL  
MAJOR  
BRANDS  
OF  
NAILERS?**

**CALL  
TODAY!**

**CALL US FOR ALL YOUR NEEDS**  
**855-785-TOOL**

**FINISH NAILERS 16 AND 15 GAUGE**

**FINISH NAILERS 16 GAUGE**

USE THIS TOOL FOR FINISHING APPLICATIONS IN CONSTRUCTION, FURNITURE AND CABINETS, PICTURE FRAMES, HARDWOOD FLOORING, MOLDING, BASEBOARD, CHAIR RAIL, PANELING, NAILABLE PLASTIC PARTS, DOOR AND WINDOW CASINGS, AND UPHOLSTERY TRIM PANELS.



ADJUSTABLE DEPTH-OF-DRIVE. ADJUSTABLE EXHAUST. LEFT OF RIGHT HAND ADJUSTABLE BELT HOOK. NO-MAR PAD TO PROTECT WORK SURFACE. INCLUDES CASE, FITTING AND OIL. TOOL WEIGHT 4.3 LBS.

**STOCK NO. SENFINISHPRO32**  
SEE LIST #5 FOR FASTENERS



LIGHTWEIGHT AND WELL BALANCED. ERGONOMIC HANDLE WITH SUREGRIP PROVIDE MORE CONTROL AND LESS FATIGUE. DEPTH-OF-DRIVE ADJUSTMENT FOR PRECISE CONTROL OF NAIL DEPTH IN HARD OR SOFT WOOD. NO WRENCHES NEEDED. TWO FINGER TRIGGER. TOOL WEIGHT 3.9 LBS.

**STOCK NO. PAS501680**  
SEE LIST #5 FOR FASTENERS



LIGHTWEIGHT MAGNESIUM DESIGN FOR ADDED DURABILITY. OIL-FREE OPERATION REQUIRES NO REGULAR MAINTENANCE AND ELIMINATES THE RISK OF OIL STAINS. ULTRA-QUIET REAR EXHAUST DIRECTS AIR AWAY FROM THE USER. ZERO NAIL LOCK-OUT FEATURE ELIMINATES DRYFIRING AND INDICATES WHEN TO RELOAD THE MAGAZINE. KIT INCLUDES: FINISH NAILERS, 1/4" AIR FITTING, 1,000 2" NAILS, CARRYING CASE, HEX WRENCHES AND FOUR PROFILE TIPS. TOOL WEIGHT 3.3 LBS.

**STOCK NO. BOSFN16250K2**  
SEE LIST #5 FOR FASTENERS

**CORDLESS FINISH NAILERS 16 GAUGE**



CORDLESS, SELF-POWERED, THE CONVENIENCE AND FREEDOM OF NO HOSES OR COMPRESSORS. NO-MAR TIP WITH SIGHT LINES PROVIDES PRECISE PLACEMENT AND PREVENTS DAMAGE TO EXPENSIVE WOOD. QUICK CLEAR NOSE COVER WITH EASY ACCESS TO REMOVE INFREQUENT JAMS. TOOL WEIGHT 4.75 LBS. (WITH BATTERY)

**STOCK NO. PAS90200**  
SEE LIST #5 FOR FASTENERS

**ANGLED FINISH NAILER 16 GAUGE**

USE THIS TOOL FOR CROWN MOLDING, BASEBOARD, CHAIR RAIL, FURNITURE, DOOR AND WINDOW CASINGS, CABINET FACE FRAMES, DECORATION, WOOD FURNITURE, HARDWOOD FLOORING, PANELING, UPHOLSTERY TRIM PANELS, TRIM TO STEEL STUDS.



COMPACT, ANGLED TRIM TOOL REACHES INTO TIGHTER SPOTS THAN STRAIGHT FINISH TOOLS. TOOL-FREE DEPT-OF-DRIVE ADJUSTMENT. NAIL LOCKOUT AT 10 NAILS PREVENTS BLANK FIRE DAMAGE TO WORK SURFACE. DIRECTION EXHAUST CAP. SOFT TEXTURED GRIP. REVERSIBLE/REMOVABLE BELT HOOK. REAR LOAD MAGAZINE WITH TWO-STEP FOLLOWER. TOOL WEIGHT 3.8 LBS.

**STOCK NO. PAS500910**  
SEE LIST #6 FOR FASTENERS

**CORDLESS ANGLED FINISH NAILER 16 GAUGE**



CORDLESS, SELF-POWERED THE CONVENIENCE AND FREEDOM OF NO HOSES OR COMPRESSORS. EASY ACCESS TO CORNERS. PERFECT FOR OVERHEAD USE. FITS INTO TIGHT SPOTS. LIGHTWEIGHT AND WELL-BALANCED. NO-MAR TIP WITH SIGHT LINES. TOOL WEIGHT 4.9 LBS. (WITH BATTERY).

**STOCK NO. PAS900600**  
SEE LIST #6 FOR FASTENERS

**ANGLED NAILERS 15 GAUGE**



RUGGED INTERNAL ENGINE DESIGN. NEVER LUBE DESIGN MEANS NO TOOL LUBRICATION TO STAIN FINE WOODS. ADJUSTABLE DEPTH-OF-DRIVE ALLOWS FOR FLUSH DRIVE OR PRECISION COUNTERSINKING. LOW RECOIL AND MORE TOOL POWER REDUCES EFFORT NEEDED FOR EACH DRIVE. TOOL WEIGHT 4 LBS.

**STOCK NO. SENFINISHPRO42**  
SEE LIST #7 FOR FASTENERS



ADJUSTABLE DEPTH-OF-DRIVE ALLOWS FOR FLUSH DRIVE OR PRECISION COUNTERSINKING. LIGHTWEIGHT THAT MAKES IT EASY TO MANEUVER IN TIGHT SPOTS. ADJUSTABLE EXHAUST. EASY-CLEAR LATCH TO CLEAR JAMS FAST. INCLUDES CASE, FITTING, OIL. TOOL WEIGHT 4.7 LBS.

**STOCK NO. SENFINISHPRO35**  
SEE LIST #7 FOR FASTENERS

**FASTENER LISTS ARE LOCATED AFTER STAPLERS**

**WE  
SERVICE  
ALL MAJOR  
BRANDS  
OF NAILERS!**

**MICRO PINNERS, COIL ROOFING AND FLOORING NAILERS**

**MICRO PINNER**



LIGHTWEIGHT MICRO PINNER IS THE PERFECT TOOL FOR CABINET DOORS, SMALL TRIM, GLAZING BEAD, CARVINGS AND ORNAMENTALS, PICTURE FRAMES, REAR EXHAUST. EASY FASTENER LENGTH ADJUSTMENT. LOW LOAD BRAD INDICATOR. COMFORT TOOL GRIP. EXTRA POWER, FOR USE IN HARDWOODS. EASY-OPEN LATCH FOR FAST LOADING. INCLUDES CASE, FITTING, OIL, AND HEX WRENCH. TOOL WEIGHT 2.35 LBS.

**STOCK NO. SENFINISHPRO10**  
 SEE LIST #8 FOR FASTENERS

**FASTENER LISTS ARE LOCATED  
 AFTER STAPLERS**

SAVE TIME  
 AND  
 MONEY.  
 TO SAVE  
 OUR CUSTOMERS  
 THE DELAY  
 AND BOTHER  
 OF  
 HUNTING  
 THROUGH  
 MANY SOURCES  
 OF SUPPLY,  
 WE CAN  
 FURNISH  
 MANY ITEMS  
 NOT LISTED  
 IN THIS  
 CATALOG.

**COIL ROOFING NAILERS**



XTREME PRO TECHNOLOGY, SIMPLY THE BEST ROOFING NAILER MONEY CAN BUY. FOR FASTENING ASPHALT, FIBERGLASS SHINGLES AND VINYL SIDING. 120 HIGH-LOAD NAIL CAPACITY. TOOL WEIGHT 5.4 LBS.

**STOCK NO. SENROOFPRO455XP**  
 SEE LIST #9 FOR FASTENERS



COMPACT, YET POWERFUL COIL ROOFING NAILER. FOR FASTENING ASPHALT, FIBERGLASS SHINGLES AND VINYL SIDING. 120 NAIL CAPACITY. TOOL WEIGHT 5.9 LBS.

**STOCK NO. SENROOFPRO450**  
 SEE LIST #9 FOR FASTENERS



ZERO NAIL LOCKOUT FEATURE ELIMINATES DRY FIRING AND INDICATES WHEN TO RELOAD THE MAGAZINE. NOSEPIECE FEATURES CARBIDE INSERTS FOR LONG-LIFE PERFORMANCE. AGGRESSIVE WEAR GUARDS AND SKID PADS PROTECT THE TOOL FROM DAMAGE ON ABRASIVE SURFACES. QUICK-SET ADJUSTABLE DEPTH GUIDE SETS NAILS TO DESIRED DEPTHS QUICKLY. PATENTED, SINGLE ACTION, SIDE LOAD CANISTER FOR FAST, ONE-STEP NAIL LOADING. ADJUSTABLE SHINGLE GUIDE FOR QUICK SHINGLE SPACING. TOOL WEIGHT 4.9 LBS.

**STOCK NO. BOSRN461**  
 SEE LIST #9 FOR FASTENERS

**FASTENER LISTS ARE LOCATED  
 AFTER STAPLERS**

**FLOORING NAILERS**



PROFESSIONAL PNEUMATIC CLEAT NAILER WITH EXCLUSIVE WORK CONTACT SAFETY THAT ACTIVATES ONLY WHEN THE TOOL IS SET DOWN. FOR HARDWOOD FLOORING 1/2" - 3/32" THICK. TOOL WEIGHT 12 LBS.

**STOCK NO. SENSF50**  
 SEE LIST #10 FOR FASTENERS

**FASTENER LISTS ARE LOCATED  
 AFTER STAPLERS**

**DOES  
 YOUR  
 NAILER  
 NEED  
 SERVICE??**

**WE  
 SERVICE  
 ALL  
 MAJOR  
 BRANDS.**

**STAPLERS 18 AND 16 GAUGE**

**18 GAUGE**



RUGGED INTERNAL ENGINE DESIGN. ADJUSTABLE DEPTH-OF-DRIVE AND EXHAUST. LEFT OR RIGHT HAND ADJUSTABLE BELT HOOK. NO-MAR PAD, OVERMOLD COMFORT GRIP AND OVERMOLD TRIGGER PAD. ON-TOOL POWER ADJUSTMENT, WITH WRENCHES ON TOOL FOR FAST ADJUSTMENTS. VERSATILE AND POWERFUL STAPLER USED FOR FURNITURE MANUFACTURING, UNDERLAYMENT SHEATHING, PANELING, MOLDING, TRIM, SOFFITS, PREFINISHED GYPSUM AND SIDING FOR ON-SITE AND MANUFACTURED HOUSING. REQUIRES NO LUBRICATION. TOOL WEIGHT 2.7 LBS.

**STOCK NO. SENSLS25XPL**  
SEE LIST #11 FOR FASTENERS



LIGHTWEIGHT AND EASY TO HANDLE WITH ERGONOMIC DESIGN AND SOFT GRIP. ADJUSTABLE DEPTH-OF-DRIVE CONTROL ALLOWS FOR PRECISE COUNTERSINKING. DESIGNED WITH ONLY ONE MOVABLE SEAL FOR VIRTUALLY TROUBLE-FREE OPERATION. VERSATILE AND POWERFUL STAPLER USED FOR FURNITURE MANUFACTURING, UNDERLAYMENT, PANELING, MOLDING/TRIM AND SOFFITS. TOOL WEIGHT 2.9 LBS.

**STOCK NO. SENSL18**  
SEE LIST #11 FOR FASTENERS



ADJUSTABLE DEPTH-OF-DRIVE. 2 IN 1 DESIGN ALLOWS FOR STAPLING AND NAILING IN A SINGLE TOOL. REAR EXHAUST. BELT HOOKS. NO-MAR PAD AND COMFORT TOOL GRIP. LOW LOAD BRAD INDICATOR. INCLUDES CASE, FITTING, OIL, AND HEX WRENCH. TOOL WEIGHT 2.75 LBS.

**STOCK NO. SENFINISHPRO2IN1**  
SEE LIST #11 FOR FASTENERS

**FASTENER LISTS ARE LOCATED AFTER STAPLERS**

**18 GAUGE**



MANEUVERABLE AND LIGHTWEIGHT. NEVER LUBE DESIGN MEANS NO TOOL LUBRICATION TO STAIN FINE WOODS. EASY TO MAINTAIN AND SERVICE, ONLY TWO MOVEABLE O-RINGS FOR VIRTUALLY TROUBLE-FREE UPKEEP. TOOL WEIGHT 2.3 LBS.

**STOCK NO. SENSLP20XP**  
SEE LIST #12 FOR FASTENERS

**16 GAUGE**



POWER, SPEED AND BALANCE TO HANDLE THE MOST DEMANDING APPLICATIONS. STAPLES ROOF AND FLOOR DECKING, SHEATHING, VINYL SIDING, SUBFLOORING, FASCIA AND SOFFITS. RUGGED INTERNAL ENGINE DESIGN. COMFORT FEATURES INCLUDE: DURABLE MOLDED COMFORT GRIP, 360° ADJUSTABLE EXHAUST, AND OVERMOLD TRIGGER. EZ-CLEAR LATCH PROVIDES QUICK AND EASY CLEARING OF OCCASIONAL JAMS. MAGNESIUM MAIN BODY. TOOL WEIGHT 4.4 LBS.

**STOCK NO. SENSNS44XP**  
SEE LIST #13 FOR FASTENERS

**FASTENER LISTS ARE LOCATED AFTER STAPLERS**

**DID YOU KNOW THAT WE SERVICE ALL MAJOR BRANDS OF STAPLERS?**

**16 GAUGE**



LIGHTWEIGHT FAST-ACTION 16 GAUGE STAPLER ALLOWS HIGH PRODUCTION ON ROOF AND FLOOR DECKING, SHEATHING, VINYL SIDING, SUBFLOORING, FASCIA AND SOFFITS. DURABLE CONSTRUCTION. TOOL WEIGHT 4.6 LBS.

**STOCK NO. SENSNS41**  
SEE LIST #13 FOR FASTENERS



VERSATILE STAPLER, DRIVES 3/4" - 2" STANDARD CROWN STAPLES. LONG BUMPER AND VALVE LIFE. EASY LOADING. CLEAR JAMS QUICKLY AND EASILY. DECREASE FATIGUE AND INCREASE PRODUCTIVITY. TOOL WEIGHT 4.9 LBS.

**STOCK NO. PAS501230**  
SEE LIST #14 FOR FASTENERS

**UPHOLSTERY - FINE WIRE**



DEPENDABLE AND VERSATILE FINE-WIRE STAPLER. STANDARD 1" LIP LENGTH. ROUNDED STEEL CAP WON'T HARM FABRIC. BOTH U.S. AND METRIC SKIRT GUIDE CAST INTO OUTER MAGAZINE, NO NEED FOR TAPE MEASURE. NO FRONT SCREW HEADS LETS TOOL GLIDE OVER FABRIC. SLENDER COMPACT TOOL DESIGN EASILY REACHES TIGHT SPOTS. RELOAD WINDOW INDICATES WHEN TO RELOAD. USE ON FURNITURE UPHOLSTERY, DUST COVERS, CABINET BACKS, FELT INSULATION, ROOFING FELT, MOLDING AND SHOEMAKING. TOOL WEIGHT 2 LBS.

**STOCK NO. SENSFW10XPC**  
SEE LIST #15 FOR FASTENERS

**FASTENER LISTS ARE LOCATED AFTER STAPLERS**

**ROOFING AND FLOORING STAPLERS AND DURASPIN**

**ROOFING STAPLER**



16 GAUGE WIDE CROWN STAPLER FOR INSULATION BOARD, ROOF FELT, LATHING, BUTT JOINTS AND CARTON-TO-SKID. ALSO CAPABLE OF HANDLING ASPHALT ROOF SHINGLES. HIGH LOAD CAPACITY - 150 STAPLES. DESIGNED FOR FAST LOADING, CONSISTENT FLUSH DRIVING. EZ-CLEAR VIRTUALLY ELIMINATES DOWNTIME CAUSED BY FASTENER JAMS. TOOL WEIGHT 4.6 LBS.

**STOCK NO. SENPW150R**  
 SEE LIST #16 FOR FASTENERS

**BUTTON CAP STAPLER**



LIGHT AND FAST BUTTON CAP STAPLER DRIVES STAPLE AND CAP IN TANDEM, FOR HOUSE WRAP AND ROOFING FELT INSTALLATION. RUGGED ALL-STEEL CONSTRUCTION. EASY LOAD SYSTEM FOR STAPLES AND CAPS. ALUMINUM HOUSING. BELT HOOK. TOOL WEIGHT 4.1 LBS.

**STOCK NO. SENBC58**  
 SEE LIST #17 FOR FASTENERS



USES A11 OR T50 SERIES STAPLES. AUTOMATIC STAPLER ADJUSTS TO DRIVE UP TO 1600 STAPLES PER MINUTE. FEATURES DOUBLE LENGTH MAGAZINE FOR LESS FREQUENT RELOADING. GOOD TOOL FOR UPHOLSTERY, INSULATION, AND FELT PAPER INSTALLATION. INDUSTRIAL QUALITY, DESIGNED FOR YEARS OF USE. AIR FITTING AND TOOL OIL INCLUDED. TOOL WEIGHT 2.75 LBS.

**STOCK NO. FAS11206F**  
 SEE LIST #18 FOR FASTENERS

**FASTENER LISTS ARE LOCATED AFTER STAPLERS**

**FLOORING STAPLER**



LIGHTWEIGHT, TONGUE-AND-GROOVE INSTALLATION STAPLER DRIVES 1" STAPLES AT A PERFECT 45° ANGLE EVERY TIME. USED TO FASTEN 1/4" - 1/2" HARDWOOD FLOORING. NO LUBRICATION IS REQUIRED. FRONT BLOCK ADJUSTS FOR DIFFERENT FLOOR THICKNESSES AND TONGUE LOCATIONS. TOOL WEIGHT 3.2 LBS.

**STOCK NO. SENSLS20HF**  
 SEE LIST #19 FOR FASTENERS

**FASTENER LISTS ARE LOCATED AFTER STAPLERS**

**PARTS AND SERVICE AVAILABLE IN HOUSE ON ALL MAJOR BRANDS OF STAPLERS AND NAILERS**

TALK IS CHEAP--EXCEPT WHEN CONGRESS DOES IT.

--CULLEN HIGHTOWER

**DURASPIN**



3300 RPM HIGH-TORQUE CORDED AC MOTOR FOR THE DEMANDING PRO. PATENTED CLUTCH DESIGN FOR LONG-LASTING DURABILITY. TRIGGER LOCK FOR CONTINUOUS WORK. EASY DEPTH-OF-DRIVE ADJUSTMENT REGULATES THE PRECISE AMOUNT OF COUNTERSINK. USE FOR DRYWALL, FLOOR SHEATHING, UNDERLAYMENT, CEMENT BOARD, FENCING, DECKING AND METAL TO METAL. TOOL WEIGHT 4.4 LBS.

**STOCK NO. SENDS200AC**  
 SEE LIST #20 FOR FASTENERS



ADJUSTABLE LENGTH DESIGN, DRIVE SCREWS FROM A COMFORTABLE STANDING POSITION. EASY DEPTH-OF-DRIVE ADJUSTMENT. QUICK RELEASE FOR EASY BIT ACCESS. SUPER TOUGH DRIVE BITS. REVERSE SWITCH TO BACK OUT DRIVEN SCREWS. USE FOR DECKING, FLOOR SHEATHING, SUBFLOORING, UNDERLAYMENT AND CEMENT BOARD. TOOL WEIGHT 8.7 LBS.

**STOCK NO. SENDS300AC**  
 SEE LIST #20 FOR FASTENERS

**DURASPIN CORDLESS**



3000 RPM HIGH-TORQUE MOTOR. PATENTED CLUTCH DESIGN FOR LONG-LASTING DURABILITY. ONE-HOUR CHARGER AND EXTRA BATTERY. EASY DEPTH-OF-DRIVE ADJUSTMENT REGULATES THE PRECISE AMOUNT OF COUNTERSINK. REVERSE SWITCH TO BACK OUT DRIVEN SCREWS. 18 VOLT BATTERY. USE FOR DRYWALL, FLOOR SHEATHING, UNDERLAYMENT, CEMENT BOARD, DECKING AND FENCING. TOOL WEIGHT 6.3 LBS.

**STOCK NO. SENDS275**  
 SEE LIST #20 FOR FASTENERS

**FASTENER LISTS ARE LOCATED AFTER STAPLERS**

## NAILS, STAPLES, AND STAPLERS

### COMMON NAILS



BULK- 50 LB. CARTONS      SOLD PER POUND

STOCK NO.	SIZE	LENGTH IN.
NC4D	4D	1-1/2
-	5D	1-3/4
NC6D	6D	2"
NC8D	8D	2-1/2
NC10D	10D	3"
-	12D	3-1/4
NC16D	16D	3-1/2
NC20D	20D	4"
-	30D	4-1/2
-	40D	5"
NC50D	50D	5-1/2

### COATED SINKER NAILS



#### FLAT COUNTERSUNK HEAD

BULK- 50 LB. CARTONS      SOLD PER POUND

STOCK NO.	SIZE	LENGTH IN.
-	6D	1-7/8
-	7D	2-1/8
NS8D	8D	2-3/8
-	10D	2-7/8
NS12D	12D	3-1/8
NS16D	16D	3-1/4
-	20D	3-3/4

### FINISH NAILS



BULK- 50 LB. CARTONS      SOLD PER POUND

STOCK NO.	SIZE	LENGTH IN.
NF3D	3D	1-1/4
NF4D	4D	1-1/2
NF6D	6D	2"
NF8D	8D	2-1/2
NF10D	10D	3"

### DOUBLE HEAD SCAFFOLD NAILS



BULK- 50 LB. CARTONS - SOLD PER POUND

STOCK NO.	SIZE	LENGTH IN.
ND8D	8D	2-1/4
ND16D	16D	3"

LENGTH IS FROM POINT TO LOWER HEAD

### GALVANIZED ROOFING NAILS

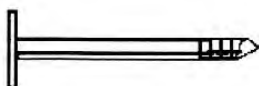

BULK- 50 LB. CARTONS      SOLD PER POUND

STOCK NO.	LENGTH IN.
NR1	1"
NR114	1-1/4
NR112	1-1/2

### HEAVY AND LIGHT DUTY STAPLES

STOCK NO.	STAPLE CENTER NO.	ORIGINAL MFG. NO.	FOR USE IN THESE UNITS
-----------	-------------------	-------------------	------------------------

#### DUOFAST

SCD14	SC-D (1/4)	508C (1/4)	CT-850
SCD516	SC-D (5/16)	5010C (5/16)	CT-859
SCD38	SC-D (3/8)	5012C (3/8)	HT-550
SCD12	SC-D (1/2)	5016C (1/2)	XE-5018
SCD916	SC-D (9/16)	5018C (9/16)	B&D *

\*BLACK & DECKER 9700, 9701, 9713, 9715

#### BOSTITCH

SCB14	SC-B (1/4)	STCR5019 (1/4)	T5-8
SCB516	SC-B (5/16)	STCR5019 (5/16)	T15
SCB38	SC-B (3/8)	STCR5019 (3/8)	ET5-8
SCB12	SC-B (1/2)	STCR5019 (1/2)	H30-8
SCB916	SC-B (9/16)	STCR5019 (9/16)	P4-8

#### CRAFTSMAN

SCC14	SC-C (1/4)	050 (1/4)	9-68642
SCC516	SC-C (5/16)	050 (5/16)	9-68643
SCC38	SC-C (3/8)	050 (3/8)	9-6847
SCC12	SC-C (1/2)	050 (1/2)	9-6844
SCC916	SC-C (9/16)	050 (9/16)	9-68472
			652-68420

#### SWINGLINE

SCS14	SC-S (1/4)	804 (1/4)	800 BOSTIK
SCS516	SC-S (5/16)	805 (5/16)	900 WARDS
SCS38	SC-S (3/8)	806 (3/8)	1000 PARKER
SCS12	SC-S (1/2)	808 (1/2)	34201
SCS916	SC-S (9/16)	809 (9/16)	
*SCSS14	SC-SS (1/4)	101-4	#101
*SCSS516	SC-SS (5/16)	101-5	#200

\*LIGHT DUTY STAPLES

#### ARROW

SCA145-M	SC-A (1/4)	T-50 (1/4)	T-50
J10019	SC-A (5/16)	T-50 (5/16)	T-50-OC
J1001901	SC-A (3/8)	T-50 (3/8)	T-55
SCA12	SC-A (1/2)	T-50 (1/2)	ET-50
SCA1732	SC-A (17/32)	T-50 (17/32)	T-50
J100191	SC-A (9/16)	T-50 (9/16)	HT-50A
SPOT85509	SC-A (9/16)	T-50 (9/16)	T-50
*SCAS14	SC-AS (1/4)	JT-21 (1/4)	JT-21
*SCAS516	SC-AS (5/16)	JT-21 (5/16)	
**SCT12	SC-T (1/2)	T-2025 (1/2)	T-25

\*LIGHT DUTY STAPLES

\*\*WIRE TACKING STAPLES

### ARROW T-50 STAPLE GUN



ALL PURPOSE, HEAVY DUTY GUN. USES ALL STAPLE SIZES FROM 1/4 TO 9/16

- HARDENED STEEL WORKING PARTS
- DOUBLE LEVERAGE
- EASE OF OPERATION
- ALL STEEL CONSTRUCTION
- CHROME FINISH

STOCK NO. MD95500

### UNIVERSAL STAPLE GUN



USES ANY HEAVY DUTY STAPLES, ALL BRANDS AND SIZES

STOCK NO. SCA5650

### POWER CROWN HAMMER TACKER



QUICK-LOAD MAGAZINE. TOOL-FREE JAM CLEARING. TOOL WEIGHT 1.8 LBS.

STOCK NO. BOSH308

USE STAPLES:

STOCK NO.      SIZE

SCB38	3/8
SCB12	1/2
BOSSTERS01938	3/8

### HAMMER STAPLER



STOCK NO. PREBF9PF09

USE ARROW SERIES STAPLES 1/4" - 3/8"

### ADDITIONAL ITEMS AVAILABLE CALL FOR DETAILS

ONE OF THE BEST WAYS TO MEASURE PEOPLE IS TO WATCH THE WAY THEY BEHAVE WHEN SOMETHING FREE IS OFFERED.

--ANN LANDERS

**FASTENERS FOR NAILERS**

**FRAMING NAILS  
LIST #1  
30 - 34 DEG.**

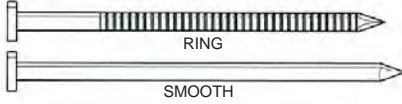

STOCK NO.	SIZE	FINISH	SHANK	BOX QTY
SENGE21ASBK	.113 X 2"	GALV	RING	2000
SENGC21APBN	.113 X 2"	BRIGHT	SMOOTH	6700
SENGC23AHAN	.113 X 2-1/4	BRIGHT	SMOOTH	1000
SENGE24ASBK	.113 X 2-3/8	GALV	RING	2000
SENGE24APBK	.113 X 2-3/8	BRIGHT	RING	2000
SENGC24APBN	.113 X 2-3/8	BRIGHT	SMOOTH	5000
PAS650238	.113 X 2-3/8	BRIGHT	RING	5000
SENHE27ASBK	.120 X 3"	GALV	RING	2000
PAS650385	.120 X 3"	GALV	RING	2000
SENHC27APB	.120 X 3"	BRIGHT	SMOOTH	3000
SENKC27APBH	.131 X 3"	BRIGHT	SMOOTH	3000
PAS650210	.131 X 3"	BRIGHT	SMOOTH	2500
SENHC28APBH	.131 X 3-1/4	BRIGHT	SMOOTH	3000
PAS650239	.131 X 3-1/4	BRIGHT	SMOOTH	2500

**FRAMING NAILS  
LIST #2  
21 DEG.**

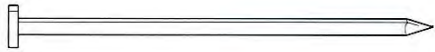

STOCK NO.	SIZE	FINISH	SHANK	BOX QTY
FALRHS8BP	.113 X 2-3/8"	BRIGHT	SMOOTH	5000
BOSRHS10D131EP	.131 X 3"	COATED	SMOOTH	4000
FALRHS10BP131	.131 X 3"	BRIGHT	SMOOTH	4000
SENKD28APBSN	.131 X 3-1/4	BRIGHT	SMOOTH	4000
FALRHS16BP	.131 X 3-1/2	BRIGHT	SMOOTH	4000

**JOIST HANGER  
POSITIVE PLACEMENT NAILS**



**LIST #3**

STOCK NO.	SIZE	FINISH	SHANK	BOX QTY
SENM002263	.148 X 1-1/2	BRIGHT	SMOOTH	2000
SENM002264	.148 X 1-1/2	GALV	SMOOTH	2000
PAS650014	.148 X 1-1/2	GALV	SMOOTH	3000
PAS650025	.131 X 1-1/2	BRIGHT	SMOOTH	4000
PAS650026	.148 X 1-1/2	THREAD	SMOOTH	3000
SENM002266	.148 X 2-1/2	GALV	SMOOTH	1500
PAS650028	.162 X 2-1/2	BRIGHT	SMOOTH	2000

**ADDITIONAL ITEMS AVAILABLE  
CALL FOR DETAILS**

**BRAD / FINISH NAILS  
18 GAUGE  
LIST #4**



STOCK NO.	SIZE	FINISH	BOX QTY
SENAV10EAA	5/8	GALV	5000
SENAV11EAA	3/4	GALV	5000
SENAV13EAA	1"	GALV	5000
PAS650212	1"	GALV	2000
SENAV15EAA	1-1/4	GALV	5000
PAS650213	1-1/4	GALV	2000
SENAV17EAA	1-1/2	GALV	5000
PAS650214	1-1/2	GALV	2000
BOSEBT1340	1-9/16	GALV	5000
SENAV18EAA	1-5/8	GALV	5000
SENAV19EAA	1-3/4	GALV	5000
SENAV21EAAAN	2"	GALV	5000
PAS650215	2"	GALV	2000
SENAV22EAAAN	2-1/8	GALV	5000

5/8 AND 3/4 SIZES ARE SLIGHT HEAD STYLE  
1" - 2-1/8 SIZES ARE MEDIUM HEAD STYLE

**STRAIGHT FINISH NAILS  
16 GAUGE  
LIST #5**



STOCK NO.	SIZE	FINISH	BOX QTY
SENM001001	1"	GALV	2000
SENM001002	1-1/4	GALV	2000
PAS650282	1-1/4	GALV	2000
SENM001003	1-1/2	GALV	2000
PAS650283	1-1/2	GALV	2000
SENM001004	1-3/4	GALV	2000
SENM001005	2"	GALV	2000
PAS650285	2"	GALV	2000
SENM001007	2-1/2	GALV	2000

**ANGLED FINISH NAILS  
16 GAUGE  
LIST #6**



STOCK NO.	SIZE	FINISH	BOX QTY
PAS650230	1-1/4	GALV	2000
PAS650231	1-1/2	GALV	2000
PAS650046	1-3/4	GALV	2000
PAS650047	2"	GALV	2000
PAS650232	2-1/2	GALV	2000

**ADDITIONAL ITEMS AVAILABLE  
CALL FOR DETAILS**

**ANGLED FINISH NAILS  
15 GAUGE  
LIST #7**



STOCK NO.	SIZE	FINISH	BOX QTY
SENDA13EPBN	1"	BRIGHT	4000
SENDA15EPBN	1-1/4	BRIGHT	4000
SENDA17EABN	1-1/2	GALV	4000
SENDA17EPBN	1-1/2	BRIGHT	4000
SENDA19EPBN	1-3/4	BRIGHT	4000
SENDA21EABN	2"	GALV	4000
SENDA21EPBN	2"	BRIGHT	4000
SENDA23EPBN	2-1/4	BRIGHT	4000
SENDA25EAB	2-1/2	GALV	3000
SENDA25EPB	2-1/2	BRIGHT	3000

**MICROPINS  
23 GAUGE  
LIST #8**



STOCK NO.	SIZE	BOX QTY
SENA100509	1/2	2600
SENA100629	5/8	2600
SENA100759	3/4	2600
SENA101009	1"	2600
SENA109809*	1/2-1"	2400 PCS

\*VARIETY PACK

**COIL ROOFING NAILS  
LIST #9**



STOCK NO.	SIZE	BOX QTY
JAMPCN32R	1-1/4	7200
JAMPCN38R	1-1/2	7200
JAMPCN45R	1-3/4	7200

**FLOORING NAILS  
LIST #10**

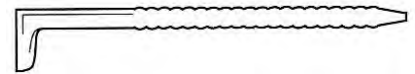

STOCK NO.	SIZE	GAUGE	BOX QTY
PN112181000	1-1/2	18	1000
SENRW21BPE	2"	16	1000
PN2161000	2"	16	1000
SENRW21BPEP	2"	16	5000
PN2165000	2"	16	5000

NEVER LET THE FEAR OF STRIKING OUT GET IN YOUR WAY.

--BABE RUTH

## STAPLES AND DURASPIN SCREWS

### 1/4" CROWN STAPLES 18 GAUGE LIST #11



STOCK NO.	SIZE	FINISH	BOX QTY
SENL06BAB	3/8	GALV	10000
SENL08BAB	1/2	GALV	10000
SENL10BABN	5/8	GALV	5000
SENL11BAB	3/4	GALV	5000
SENL11BRB	3/4	BRIGHT	5000
SENL12BAB	7/8	GALV	5000
SENL13BABN	1"	GALV	5000
SENL14BRB	1-1/8	BRIGHT	5000
SENL15BAB	1-1/4	GALV	5000
SENL15BRB	1-1/4	BRIGHT	5000
SENL17BAB	1-1/2	GALV	5000

### 3/8" CROWN STAPLES 18 GAUGE LIST #12



STOCK NO.	SIZE	FINISH	BOX QTY
SENM11BABN	3/4	GALV	5000
SENM13BAB	1"	GALV	5000

### 7/16" CROWN STAPLES 16 GAUGE LIST #13



STOCK NO.	SIZE	FINISH	BOX QTY
SENN13BAB	1"	GALV	5000
SENN15BAB	1-1/4	GALV	10000
SENN15BRB	1-1/4	BRIGHT	10000
SENN17BAB	1-1/2	GALV	10000
SPOT6612PL	1-1/2	GALV	10000
SENN19BAB	1-3/4	GALV	10000
SENN21BAB	2"	GALV	10000
SENN21BRB	2"	BRIGHT	10000

### 1/2" CROWN STAPLES 16 GAUGE LIST #14



STOCK NO.	SIZE	FINISH	BOX QTY
PAS075240	3/4	GALV	21000
PAS072695	1-1/2	GALV	10500
PAS400028	1-1/2	BRIGHT	10500
SENM004064	1-1/2	GALV	10000
SENM004065	1-3/4	GALV	10000
SENM004066	2"	GALV	10000

**ADDITIONAL ITEMS AVAILABLE  
CALL FOR DETAILS**

### 3/8" CROWN STAPLES 22 GAUGE LIST #15



STOCK NO.	SIZE	FINISH	BOX QTY
SENC06BAAP	3/8	GALV	50000
SENC06BGA	3/8	STAINLESS	10000
SENC08BAAP	1/2	GALV	35000

### 1" CROWN ROOFING STAPLES 16 GAUGE LIST #16



STOCK NO.	SIZE	FINISH	BOX QTY
SENP11BAB	3/4	GALV	10000
SENP12BAB	7/8	GALV	10000
SENP13BAB	1"	GALV	10000
SENP15BAB	1-1/4	GALV	10000
SENP17BAB	1-1/2	GALV	10000

### 5/8" BUTTON CAPS 21 GAUGE LIST #17



STOCK NO.	SIZE	CROWN	BOX QTY
SENM004092	5/8	5/8	2200

### 3/8" CROWN FELT STAPLES LIST #18



STOCK NO.	SIZE	BOX QTY
SCA145M	1/4	5000
JI0019	5/16	5000
JI001901	3/8	5000
SCA12	1/2	4000
SCA1732	17/32	1250
JI00191	9/16	3000

### FLOORING STAPLES 19 GAUGE - GALVANIZED



STOCK NO.	SIZE	CROWN	BOX QTY
SENR13BAB	1"	3-16	5000

**ADDITIONAL ITEMS AVAILABLE  
CALL FOR DETAILS**

### DURASPIN SCREWS LIST #20



STOCK NO.	SIZE	USAGE	BOX QTY
SEN06A125P	6 X 1-1/4	DRYWALL	1000
SEN06A125PB	3 X 1-1/4	DRYWALL	4000
SEN06A162P	6 X 1-5/8	DRYWALL	1000
SEN06A162PB	6 X 1-5/8	DRYWALL	4000
SEN08D200W	8 X 2"	DECKING	1000
SEN08D250W	8 X 2-1/2	DECKING	800
SEN08D300W	8 X 3"	DECKING	800
SEN08F200Y	8 X 2"	FLOORING	1000
SEN08S250W003	8 X 2-1/2	GRAY COMPOSITE DECKING	800
SEN08S250W	8 X 2-1/2	TAN COMPOSITE DECKING	800
SEN08S250WS96	8 X 2-1/2	RED COMPOSITE DECKING	800
SEN08S300W003	8 X 3"	GRAY COMPOSITE DECKING	800
SEN08T125W	8 X 1-1/4	UNDER- LAYMENT	1000

**ADDITIONAL ITEMS AVAILABLE  
CALL FOR DETAILS**

IF YOU  
DON'T  
SEE  
SOMETHING  
HERE  
YOU  
NEED,  
GIVE US  
A  
CALL.  
WE WILL  
DO OUR  
BEST TO  
FIND  
IT  
FOR YOU.



**PNEUMATIC NAILERS PARTS AND ACCESSORIES**

**HOSE WITHOUT FITTINGS**



RUBBER HOSE HANDLES UP TO 250 PSI WORKING PRESSURE. 4 TO 1 WORKING PRESSURE TO BURST SAFETY FACTOR. OIL RESISTANT NITRILE TUBE. TOUGH, FLEXIBLE NEOPRENE COVER. BRAIDED TEXTILE REINFORCING FOR MAXIMUM STRENGTH AND KINK RESISTANCE. REMAINS FLEXIBLE IN ALL WEATHER.

STOCK NO.	SIZE	DESCRIPTION
SENPC0045	1/4 X 50'	PUSH ON AIR HOSE
SENPC0046	1/4 X 100'	PUSH ON AIR HOSE
SENPC0048	3/8 X 50'	PUSH ON AIR HOSE
SENPC0049	3/8 X 100'	PUSH ON AIR HOSE

**HOSE FITTINGS**

FOR USE ON LOCK IN STYLE HOSE ONLY. EASY PUSH ON ASSEMBLY. MATES WITH SENCO HOSE SHOWN ABOVE.

**MALE HOSE BARB**



STOCK NO.	HOSE I.D.	NPT THREAD
AM401L	1/4"	1/4"
AM406L	3/8"	1/4"
AM606L	3/8"	3/8"

**FEMAL HOSE BARB - 2 PIECE**



STOCK NO.	HOSE I.D.	NPT THREAD
AM442L	1/4"	1/4"
AM662L	3/8"	3/8"

**FEMALE HOSE BARB - 1 PIECE**



STOCK NO.	HOSE I.D.	NPT THREAD
AM441L	1/4"	1/4"
AM461L	3/8"	1/4"
AM661L	3/8"	3/8"

**SPLICERS**



STOCK NO.	DESCRIPTION.
AM402L	1/4" HOSE
AM602L	3/8" HOSE

**COUPLERS - BARBED LOCK IN STYLE**



STOCK NO.	HOSE BARB
AMC2042LB	1/4"
AMC2044LB	3/8"

**PLUGS - BARBED LOCK IN STYLE**



STOCK NO.	HOSE BARB
AMCP2142L	1/4"
AMCP2144L	3/8"
AMCP2546L	3/8"

**COMPRESSOR PUMP OIL**



RECOMMENDED FOR ALL OIL-SPLASH COMPRESSORS. PROTECTS AGAINST CORROSION. LUBRICATES TO EXTEND PART LIFE.

STOCK NO. SENPC0344 (32 OZ)

**PNEUMATIC TOOL OIL**



PROTECTS AGAINST CORROSION AND SLUDGE BUILDUP. LUBRICATES TO EXTEND PART LIFE.

STOCK NO. SENPC0101 (8 OZ)

**ADDITIONAL ITEMS AVAILABLE  
 CALL FOR DETAILS**

**DURASPIN ACCESSORIES  
 PHILLIPS #2 SCREW BITS**



STOCK NO.	SIZE	FOR MODELS
SENEA0124	#2 X 8" (2 PK)	DS200,DS200-S4, DS200-S2
SENEA0128	#2 X 9" (2 PK)	DS300,DS300-S2, DS300-S4
SENEA0142	5 PK	REPLACEMENT TIPS

**DURASPIN ACCESSORIES  
 SQUARE #2 SCREW BITS**



STOCK NO.	SIZE	FOR MODELS
SENEA0123	#2 X 5" (2 PK)	DS200-14V
SENEA0125	#2 X 8" (2 PK)	DS200,DS200-S4, DS200-S2
SENEA0143	5 PK	REPLACEMENT TIPS

**DURASPIN BIT HOLDER**



HEX POWER BIT HOLDER.

STOCK NO.	SIZE	FOR MODELS
SENWC0070	6"	DS275, DS300

**TOOL BELT HOOKS**



STOCK NO.	SIZE
SENPC0350	1/4" STANDARD
SENPC0351	3/8" STANDARD
SENPC0629	1/4" EXTRA-WIDE
SENPC0630	3/8" EXTRA-WIDE

**PNEUMATIC NAILERS PARTS AND ACCESSORIES**

**PASLODE  
BATTERIES AND ACCESSORIES  
FOR CORDLESS "IMPULSE" TOOLS**

**6V RECHARGEABLE BATTERY**



STOCK NO. PASPART404717

**BATTERY CHARGER**



STOCK NO. PASPART900200

**TALL RED FUEL CELL**



FOR FRAMING NAILERS  
STOCK NO. PAS816000

**TALL YELLOW FUEL CELL**



FOR 16 GAUGE FINISH NAILERS.  
STOCK NO. PAS816001

**SHORT YELLOW FUEL CELL**



FOR BRAD AND FINISH NAILERS.  
STOCK NO. PAS650039

**"IMPULSE" OIL**



FORMULATED AS A LUBRICANT SPECIFICALLY FOR PASLODE CORDLESS "IMPULSE" TOOLS.

STOCK NO. PASPART401482 (4 OZ)

**DEGREASER SAFETY SOLVENT**



CLEANS BOTH PNEUMATIC AND CORDLESS TOOLS. WILL NOT HARM ELECTRICAL COMPONENTS. NON-CFC. SAFE ON PLASTIC, CLEANS AND DRIES QUICKLY.

STOCK NO. PASPART219086 (12 OZ)

**ADDITIONAL ITEMS AVAILABLE  
CALL FOR DETAILS**

**THIS SPACE  
RESERVED  
FOR FUTURE  
INVENTORY  
ITEMS**



NITTO



## REVOLUTIONIZE YOUR DRILLING!

NITTO KOHKI HAS BEEN PRODUCING AUTOMATIC MAGNETIC DRILLS SINCE 1984 AND HAS BEEN THE WORLD LEADER IN THIS TECHNOLOGY. DON'T BE FOOLED BY "COPY CAT" DRILLS THAT DON'T OFFER FOLLOWING FEATURES:

**SLOW START MECHANISM.** THE FEED SPEED IS REDUCED FOR THE FIRST FEW SECONDS AFTER BORING BEGINS TO ENSURE A SMOOTH CUT THROUGH THE MILL SCALE.

**AUTO FEED.** AUTOMATIC CONTROL AND FEED ARE ACTIVATED BY SIMPLY PUSHING THE ROD HANDLE TO ENGAGE THE GEARS.

**LOAD SENSOR.** THE MICROPROCESSOR CONTROLLED DUAL SENSING SYSTEM RESPONDS TO BOTH DRILLING AND FEEDING FORCES ON THE CUTTER FOR THE OPTIMUM CUTTING PRESSURE.

**CYCLE STOP.** AFTER THE CUT HAS FINISHED, A DETECTOR RESPONDS TO THE REDUCTION IN LOAD AND BOTH THE DRILL AND THE FEED MOTOR AUTOMATICALLY STOP.

**OVERLOAD STOP.** WHEN AN EXCESSIVE LOAD IS APPLIED TO THE CUTTER, BOTH THE DRILL AND THE FEED MOTOR WILL STOP AUTOMATICALLY TO PREVENT DAMAGE TO THE CUTTER.

**ONE-TOUCH CUTTER REPLACEMENT.** REPLACEMENT IS QUICK AND EASY WITH THEIR UNIQUE PUSH FIT SELF-CENTERING CUTTER SYSTEM.

**COOLANT INTO THE HEART OF THE CUT.** COOLANT IS FED DIRECTLY TO THE INSIDE OF THE CUT. THE COOLANT SYSTEM ALSO FEATURES AN AUTO SHUT-OFF.

**BUILT-IN MOTION SENSOR.** IF ANY LATERAL MOVEMENT OR EXCESSIVE VIBRATION IS DETECTED, BOTH THE DRILL AND THE FEED MOTOR STOP INSTANTLY. NITTO KOHKI IS THE FIRST COMPANY TO INCORPORATE THIS FEATURE INTO MAGNETIC BASE DRILLS.

**FAIL SAFE RESTART.** THE DRILL WILL NOT RE-START EVEN IF POWER IS RE-SUPPLIED AFTER ACCIDENTAL SHUT-DOWN. DRILLING CAN ONLY BE CONTINUED ONCE MAGNET POWER HAS BEEN TURNED OFF AND ON AGAIN.

**MAGNET OPEN-CIRCUIT SENSOR.** THE DRILL WILL NOT START UNTIL THE MAGNETIC FIELD IS ACTIVE.

**CARBIDE TIPPED ANNULAR CUTTER.** PROVIDE 5 TIMES THE LIFE OF TRADITIONAL HIGH SPEED STEEL CUTTERS.

**MULTIPLE DRILLS CAN BE CONTROLLED BY ONE OPERATOR.**

### AUTOMATIC FEED MAGNETIC DRILL WA-3500



CAPACITY 1 3/8" DIAMETER X 2" MATERIAL THICKNESS. SINGLE SPEED 950 RPM (NO LOAD SPEED),

**STOCK NO. NKWA3500**

### AUTOMATIC FEED MAGNETIC DRILL WA-5000



CAPACITY 2" DIAMETER X 3" MATERIAL THICKNESS. 2-SPEED 350/650 RPM (NO LOAD SPEED).

**STOCK NO. NKWA5000**

### AUTOMATIC FEED MAGNETIC DRILL QA-5000



CAPACITY 2" DIAMETER X 3" MATERIAL THICKNESS. 2-SPEED 400/750 RPM (NO LOAD SPEED). IN ADDITION TO THE ABOVE FEATURES, THIS UNIT AUTOMATICALLY RETRACTS THE CUTTER FROM THE HOLE AFTER THE CUT IS FINISHED

**STOCK NO. NKQA5000**



**NITTO**



**MANUAL FEED MAGNETIC DRILL  
UO-3500**



- 1 3/8" X 2" HOLE DRILLING CAPACITY.
- LIGHTWEIGHT 31 LB. DESIGN.
- DESIGNED TO USE HIBROACH HSS ANNULAR CUTTERS.
- ONE HORSEPOWER 400 RPM MOTOR.
- REVERSIBLE FEED SHAFT ASSEMBLY FOR LEFT OR RIGHT OPERATION.
- SEALED THROUGH SPINDLE COOLANT SYSTEM.
- SELF CONTAINED IN-FRAME COOLANT RESERVOIR.
- BUILT IN MOTION DETECTION SENSOR.

STOCK NO. **NKU03500**

**CHUCK EXTENSION**



USED WITH THE TWIST DRILL CHUCK BELOW TO ADAPT THE MODEL UO3500 AND UOJ3500 MAGNETIC DRILL FOR USE WITH TWIST DRILLS.

STOCK NO. **NKUEA00280**

**1/2" TWIST DRILL CHUCK**



USED WITH CHUCK EXTENSION. (SHOWN ABOVE)

STOCK NO. **NKUZ00280**

ADDITIONAL ITEMS AVAILALBE  
UPON REQUEST

**MANUAL FEED MAGNETIC DRILL  
UOJ-3500**



- 1 3/8" X 2" HOLE DRILLING CAPACITY.
- LIGHTWEIGHT 31 LB. DESIGN.
- DESIGNED TO USE JETBROACH CARBIDE TIPPED ANNULAR CUTTERS.
- ONE HORSEPOWER 700 RPM MOTOR.
- REVERSIBLE FEED SHAFT ASSEMBLY FOR LEFT OR RIGHT OPERATION.
- SEALED ARBOR WITH THROUGH SPINDLE COOLANT.
- SELF CONTAINED IN-FRAME COOLANT RESERVOIR.
- BUILT IN MOTION DETECTION SENSOR.
- ONE TOUCH ARBOR SYSTEM "NO TOOLS REQUIRED FOR CUTTER INSTALLATION AND REMOVAL".

STOCK NO. **NKU0J3500**

**NITTO LUBRICANT**



DESIGNED FOR USE WITH CARBIDE TIP ANNULAR CUTTERS. 1 GALLON OF LUBRICANT CONCENTRATE MAKES 11 GALLONS OF SOLUTION (10:1 MIX WITH WATER)

STOCK NO. **NKTP002340**

**PARTS  
AND  
SERVICE  
AVAILABLE  
IN HOUSE  
ON ALL  
NITTO KOHKI  
DRILLS**

**MANUAL FEED MAGNETIC DRILL  
UOJ-5500**



THE WORLD'S FIRST MANUAL FEED MAG DRILL WITH "SMART STOP/RAPID RESTART" TECHNOLOGY. IF ORPERATOR APPLIES TOO MUCH FEED PRESSURE, THE DRILL AUTOMATICALLY STOPS. WHEN FEED PRESSURE IS RELEASED, DRILL AUTOMATICALLY RESTARTS. FEATURES:

- 2 3/16" X 3" HOLE DRILLING CAPACITY.
- LIGHTWEIGHT 39.6 LB. DESIGN.
- DESIGNED TO USE JETBROACH CARBIDE TIPPED ANNULAR CUTTERS.
- 2 SPEED 350/650 RPM MOTOR.
- SEALED ARBOR WITH THROUGH SPINDLE COOLANT.
- SELF CONTAINED IN-FRAME COOLANT RESERVOIR.
- BUILT IN MOTION DETECTION SENSOR.
- ONE TOUCH ARBOR SYSTEM "NO TOOLS REQUIRED FOR CUTTER INSTALLATION AND REMOVAL".

STOCK NO. **NKU0J5500**

**TOOL BALANCERS**



TOOL BALANCERS, WHEN USED PROPERLY SIZED AND ADJUSTED, MAKE ANY TOOL WEIGHTLESS TO ELIMINATE OPERATOR FATIGUE.

STOCK NO.	CAPACITY	
	LBS.	STROKE FT
TW1R	1.1-3.3	4.92
TW00	1.1-3.3	1.64
TW0	1.1-3.3	3.28
<b>NKTW30</b>	2.2-6.6	4.27
TW5	5.5-11.0	4.27
TW9	9.9-19.8	4.27
TW15	19.8-33.1	4.27
TW22	33.1-48.5	4.92
TW30	48.5-66.1	4.92
TW40	66.1-88.2	4.92
TW50	88.2-110.3	4.92
TW60	110.3-132.3	4.92
TW70	132.3-154.3	4.92



NITTO



JET BROACH CARBIDE CUTTER



STANDARD CUTTERS ARE DESIGNED FOR SOLID MATERIALS. I.D. CUTTERS, COMMONLY REFERRED TO AS "STACK" CUTTERS ARE DESIGNED TO DRILL THROUGH 3" OF STACKED PLATES IN ONE CONTINUOUS PASS. I.D. CUTTERS CAN ALSO BE USED ON 3" THICK SOLID MATERIAL.

STOCK NO.	SIZE	TYPE	PILOT PIN REFERENCE
NK0005	11/16 x 1-3/8	S	G
NK0006	3/4 x 1-3/8	S	G
NK0007	13/16 x 1-3/8	S	G
NK0008	7/8 x 1-3/8	S	G
NK0009	15/16 x 1-3/8	S	G
NK0010	1" x 1-3/8	S	G
NK0011	1-1/16 x 1-3/8	S	G
NK0012	1-1/8 x 1-3/8	S	G
NK0013	1-3/16 x 1-3/8	S	G
NK0014	1-1/4 x 1-3/8	S	G
NK0015	1-5/16 x 1-3/8	S	G
NK0016	1-3/8 x 1-3/8	S	G
NK0017	1-7/16 x 1-3/8	S	G
NK0018	1-1/2 x 1-3/8	S	G
NK0019	1-9/16 x 1-3/8	S	G
NK0041	11/16 x 2	S	H
NK0042	3/4 x 2	S	H
NK0043	13/16 x 2	S	H
NK0044	7/8 x 2	S	H
NK0045	15/16 x 2	S	H
NK0046	1" x 2	S	H
NK0047	1-1/16 x 2	S	H
NK0048	1-1/8 x 2	S	H
NK0049	1-3/16 x 2	S	H
NK0050	1-1/4 x 2	S	H
NK0051	1-5/16 x 2	S	H
NK0052	1-3/8 x 2	S	H
NK0053	1-7/16 x 2	S	H
NK0054	1-1/2 x 2	S	H
NK0055	1-9/16 x 2	S	H
NK0056	1-5/8 x 2	S	H
NK0057	1-11/16 x 2	S	H
NK0058	1-3/4 x 2	S	H
NK0059	1-13/16 x 2	S	H
NK0060	1-7/8 x 2	S	H
NK0061	1-15/16 x 2	S	H
NK0062	2" x 2	S	H
0063	2-1/16 x 2	S	H
NK0064	2-1/8 x 2	S	H
NK0065	2-3/16 x 2	S	H
NK0066	2-1/4 x 2	S	H
NK0068	2-3/8 x 2	S	H
NK0070	2-1/2 x 2	S	H
0119	11/16 x 3	S	I
NK0120	3/4 x 3	S	I
0080	3/4 x 3	ID	I
0121	*13/16 x 3	S	I
NK0081	13/16 x 3	ID	I
NK0122	7/8 x 3	S	I
0082	7/8 x 3	ID	I
0123	15/16 x 3	S	I
NK0083	15/16 x 3	ID	I

(CONTINUED NEXT COLUMN)

JET BROACH CARBIDE CUTTER  
(CONTINUED)



STOCK NO.	SIZE	TYPE	PILOT PIN REFERENCE
0124	1" x 3	S	I
NK0084	1" x 3	ID	I
0125	1-1/16 x 3	S	I
NK0085	1-1/16 x 3	ID	I
NK0126	1-1/8 x 3	S	I
0086	1-1/8 x 3	ID	I
NK0127	1-3/16 x 3	S	I
NK0087	1-3/16 x 3	ID	I
NK0128	1-1/4 x 3	S	I
NK0088	1-1/4 x 3	ID	I
NK0129	1-5/16 x 3	S	I
NK0089	1-5/16 x 3	ID	I
NK0130	1-3/8 x 3	S	I
0090	1-3/8 x 3	ID	I
0131	1-7/16 x 3	S	I
NK0091	1-7/16 x 3	ID	I
0132	1-1/2 x 3	S	I
NK0092	1-1/2 x 3	ID	I
0133	1-9/16 x 3	S	I
NK0093	1-9/16 x 3	ID	I
NK0134	1-5/8 x 3	S	I
0094	1-5/8 x 3	ID	I
0135	1-11/16 x 3	S	I
0095	1-11/16 x 3	ID	I
NK0136	1-3/4 x 3	S	I
0096	1-3/4 x 3	ID	I
0137	1-13/16 x 3	S	I
NK0097	1-13/16 x 3	ID	I
0138	1-7/8 x 3	S	I
NK0098	1-7/8 x 3	ID	I
0139	1-15/16 x 3	S	I
0099	1-15/16 x 3	ID	I
NK0140	2" x 3	S	I
0100	2" x 3	ID	I
0141	2-1/16 x 3	S	I
0168	1" x 4	ID	J
NK0169	1-1/16 x 4	ID	J
NK0171	1-3/16 x 4	ID	J

SEE HOW  
WE  
MAKE THE  
DIFFERENCE!

HI BROACH CUTTER



STOCK NO.	SIZE	PILOT PIN REFERENCE
NK0250	7/16 x 1	INCLUDED
NK0251	1/2 x 1	INCLUDED
NK0252	9/16 x 1	C
NK0253	5/8 x 1	C
NK0254	11/16 x 1	F
NK0255	3/4 x 1	F
NK0256	13/16 x 1	F
NK0257	7/8 x 1	F
NK0258	15/16 x 1	F
NK0259	1 x 1	F
NK0260	1-1/16 x 1	F
NK0261	1-1/8 x 1	F
NK0262	1-3/16 x 1	F
NK0263	1-1/4 x 1	F
NK0264	1-5/16 x 1	F
NK0265	1-3/8 x 1	F
NK0280	7/16 x 2	INCLUDED
NK0281	1/2 x 2	INCLUDED
NK0282	9/16 x 2	D
NK0283	5/8 x 2	D
0284	11/16 x 2	D
0285	3/4 x 2	D
0286	13/16 x 2	D
0287	7/8 x 2	D
0288	15/16 x 2	D
0289	1" x 2	D
0290	1-1/16 x 2	D
0291	1-1/8 x 2	D
0292	1-3/16 x 2	D
0293	1-1/4 x 2	D
0294	1-5/16 x 2	D
0295	1-3/8 x 2	D

PILOT PINS FOR ANNULAR CUTTER



STOCK NO.	SIZE	REFERENCE LETTER
NKUEA05250	3/16 x 1	A
NKUEA05500	3/16 x 2	B
NKUEA06250	1/4 x 1	C
NKUEA06500	1/4 x 2	D
NKUEA06700	1/4 x 3	E
NKUEA08250	5/16 x 1	F
NKUEA08350	5/16 x 1-3/8	G
NKUEA08500	5/16 x 2	H
NKUEA08750	5/16 x 3	I
NKUEA08000	5/16 x 4	J

A FANATIC IS SOMEONE WHO CAN'T CHANGE HIS MIND AND WON'T CHANGE THE SUBJECT.  
--WINSTON CHURCHILL



**BLOW GUNS AND AIR LINE ACCESSORIES**



**SPECIAL PURPOSE BLOW GUNS WITHOUT SAFETY BY-PASS STANDARD BLOW GUN**



SIMPLE, RUGGED BLOW GUN. COMFORTABLE IN THE HAND. HANG-UP HOOK. 1/4" FEMALE NPT INLET THREAD AND 1/8" FEMALE NPT OUTLET THREAD. OUTLET THREAD ACCEPTS FULL RANGE OF ACCESSORIES.

STOCK NO. AM200

REPLACEMENT BLOW GUN TIP FOR AM200  
STOCK NO. AM200T

**RUBBER TIPPED BLOW GUN**



PROVIDES LEAK-PROOF SEAL BETWEEN GUN AND FLUID LINE OR OTHER OPENING. ALSO EXCELLENT FOR CLEANING MOLDS OR DELICATE SURFACES WHERE A METAL TIP MIGHT SCRATCH OR OTHERWISE HARM CRITICAL AREAS.

STOCK NO. AM201

RUBBER TIP REPLACEMENT FOR AM201  
STOCK NO. AM202

**SAFETY BLOW GUNS**

ARE EQUIPPED WITH A SAFETY BY-PASS TO PREVENT BUILDUP OF TIP PRESSURE IN EVENT OF TIP BLOCKAGE. 1/4" NPT INLET THREAD ON ALL MODELS.



BASIC SAFETY BLOW GUN FOR GENERAL PURPOSE USE. TIP SWIVELS FREELY TO DISCOURAGE TAMPERING. TIP PRESSURE WILL NOT EXCEED 30 PSI, YET GIVES A GOOD BLAST OF AIR FOR CLEANING.

STOCK NO. AM20430A



SAFETY BOOSTER BLOW GUN SIMILAR TO AM20430A, BUT HAS BOOSTER TIP FOR GREATLY INCREASED AIR FLOW. THE ADDITIONAL AIR IS DRAWN IN THROUGH THE VENTURI SLOTS.

STOCK NO. AM208

**BLOW GUN SAFETY EXTENSIONS**



EXTENSIONS HAVE SAFETY BYPASS AND CANNOT BE DEAD ENDED.

STOCK NO. AM204E12 (12 IN)  
STOCK NO. AM204E24 (24 IN)  
STOCK NO. AM204E36 (36 IN)

**HYDRO-BLAST CLEANING GUN**



USES A SIPHON TO SPRAY SOLVENTS OR DETERGENT SOLUTIONS. CONNECTS TO A REGULAR GARDEN HOSE AND A 1/4" NPT COMPRESSED AIR LINE TO BLAST OFF DIRT AND RESIDUE. USED IN GARAGES AND FACTORIES TO BLAST CAKED-ON DIRT FROM VEHICLES AND EQUIPMENT. CAN BE USED WITH HOT OR COLD WATER. VALVE BODY STAYS COOL EVEN WHEN USED WITH HOT WATER.

STOCK NO. DESCRIPTION

AM230 INCLUDES VALVE BODY, 2" AND 15" EXTENSIONS, SIX FOOT SIPHON TUBING AND ADAPTER FOR GARDEN HOSE.

**VALVES FOR AIR LINES**

**METAL TANK FILLER VALVE**

USED ON COMPRESSED AIR TANKS AND OTHER APPLICATIONS. STANDARD VALVE STEM THREAD.



STOCK NO. AM701 (1/8 NPT)  
STOCK NO. AM7012 (1/4 NPT)

**BLEEDER VALVE**

SIMPLE PUSH BUTTON VALVE FOR BLEEDING COMPRESSED AIR LINES OR LIQUID SYSTEMS. PLATED BRASS 1/8" NPT.



STOCK NO. AM711

**BRASS IN-LINE SWIVELS**



IN-LINE SWIVELS INSTALLED BETWEEN SUPPLY HOSE AND TOOL ELIMINATE KINKS IN AIR HOSE.

STOCK NO. SIZE  
AM344R 1/4  
AM366R 3/8

**CHUCKS FOR LIVE AIR LINES**

THESE CHUCKS ARE DIRECT CONNECTION TO "LIVE AIR LINES ONLY." THEY HAVE A BUILT-IN SHUTOFF VALVE AND WILL **NOT** WORK ON INFLATOR GAUGES.



**DUAL FOOT CHUCK**

TAPERED NUT FITS WHEEL COVER HOLES. CHROME PLATED. 1/4" NPT.

STOCK NO. AM108

**BALL FOOT CHUCK**

SOLID BRASS. 1/4" NPT FEMALE THREAD



STOCK NO. AP699

**TIRE PRESSURE GAUGES**



**POCKET GAUGE**

POPULAR ANGLE HEAD DESIGN. CALIBRATED TO 0-50 PSI.

STOCK NO. AM901



**DUAL FOOT SERVICE GAUGE**

A HEAVY DUTY GAUGE DESIGNED FOR LONG TROUBLE FREE SERVICE. ANGLED DOUBLE FOOT HAS BARREL EXTENSION FOR EASY SERVICING OF DUAL WHEELS. EXTRA HEAVY POLISHED PLATE FINISH. CALIBRATED 0-130 PSI.

STOCK NO. AP599

**MIST COOLANT UNIT**



FOR DRILLING, MILLING, GRINDING AND TURNING. COOLS THE WORK AND PROLONGS TOOL LIFE. SETS UP IN SECONDS WITHOUT TOOLS. POWERFUL COMPOUND MAGNET BASE HOLDS FAST TO ANY FLAT STEEL SURFACE. A SINGLE KNOB CONTROLS MOVEMENT IN ALL DIRECTIONS. ANGLED SPOUT SWIVELS 360°. AIR AND FLUID ARE INDIVIDUALLY CONTROLLED FOR PERFECT SPRAY. DELIVERS FINE UNIFORM MIST SPRAY RIGHT TO THE WORK. WILL NOT SPIT, SPUTTER OR DRIP. POWERED BY SHOP AIR ONLY. MINIMUM PRESSURE 60 PSI, MAXIMUM PRESSURE 175 PSI.

STOCK NO. AM270

**RECOIL AIR HOSE**



STOCK NO.	DESCRIPTION	MALE ENDS
AM2410	1/4 x 10' POLY RECOIL HOSE	1/4 NPT
AM2420	1/4 x 20' POLY RECOIL HOSE	1/4 NPT
AM2430	1/4 x 30' POLY RECOIL HOSE	1/4 NPT
AM2610	3/8 x 10' POLY RECOIL HOSE	3/8 NPT
AM2620	3/8 x 20' POLY RECOIL HOSE	3/8 NPT
AM2630	3/8 x 30' POLY RECOIL HOSE	3/8 NPT



**COUPLERS AND PLUGS**  
QUICK DISCONNECT COUPLERS-PERMIT THE FASTEST, EASIEST AND MOST RELIABLE MEANS OF JOINING AIRLINES.



**INDUSTRIAL INTERCHANGE**

INTERCHANGE WITH HANSEN, FOSTER, ARO, HI-LO, MILTON.  
PLATED STEEL COUPLERS HAVE STAINLESS STEEL BALLS AND SPRINGS.  
WORKING PRESSURE 300 PSI.



STYLE A - MALE THREAD COUPLER



STYLE B - FEMALE THREAD COUPLER



STYLE C - HOSE BARB COUPLER



STYLE A - MALE THREAD PLUG



STYLE B - FEMALE THREAD PLUG



STYLE C - HOSE BARB PLUG

**STYLE A - 1/4" SERIES**

MALE NPT	COUPLERS		PLUGS	
	PLATED STEEL	BRASS	PLATED STEEL	BRASS
1/8"	-	-	-	-
1/4"	AMC21	AMC21B	AMCP21	-
3/8"	AMC2103	AMC2103B	AMCP2103	-

**STYLE A - 3/8" SERIES**

MALE NPT	COUPLERS	PLUGS
	PLATED STEEL	PLATED STEEL
1/4"	C2502	AMCP2502
3/8"	AMC25	AMCP25
1/2"	C2504	AMCP2504

**STYLE A - 1/2" SERIES**

MALE NPT	COUPLERS		PLUGS	
	PLATED STEEL	BRASS	PLATED STEEL	BRASS
3/8"	C903	-	AMCP903	-
1/2"	AMC9	-	AMCP17	-
3/4"	-	-	-	-

**STYLE B - 1/4" SERIES**

FEMALE NPT	COUPLERS		PLUGS	
	PLATED STEEL	BRASS	PLATED STEEL	BRASS
1/8"	-	-	-	-
1/4"	AMC20	AMC20B	AMCP20	-
3/8"	AMC2023	-	AMCP2023	-

**STYLE B - 3/8" SERIES**

FEMALE NPT	COUPLERS	PLUGS
	PLATED STEEL	PLATED STEEL
1/4"	-	AMCP2622
3/8"	AMC26	AMCP26
1/2"	C2624	-

**STYLE C - 1/4" SERIES**

HOSE BARB	COUPLERS		PLUGS	
	PLATED STEEL	BRASS	PLATED STEEL	BRASS
1/4"	AMC2042	-	AMCP2142	-
5/16"	-	-	-	-
3/8"	AMC2044	AMC2044B	AMCP2144	-

**STYLE C - 3/8" SERIES**

HOSE BARB	COUPLERS	PLUGS
	PLATED STEEL	PLATED STEEL
1/4"	-	-
3/8"	AMC2644	AMCP2544
1/2"	AMC2645	AMCP2545

**STYLE C - 1/2" SERIES**

HOSE BARB	COUPLERS		PLUGS	
	PLATED STEEL	BRASS	PLATED STEEL	BRASS
3/8"	-	-	-	-
1/2"	AMC1045	-	AMCP1745	-
3/4"	-	-	-	-

**BRASS AUTOMATIC COUPLER**  
*PUSH-TO-CONNECT*

INTERCHANGE WITH ARO, TRU-FLATE, INDUSTRIAL. BRASS BODY, NBR SEAL, STAINLESS STEEL SPRING. STEEL LOCKING BALLS. GOOD FOR LOW PRESSURE FLUID LINES. MAX OPERATING PRESSURE TO 220 PSI.



MALE

FEMALE

1/4" PIPE THREAD

1/4" PIPE THREAD

STOCK NO. MID28579

STOCK NO. MID28560

THE PHOTOGRAPHER HAD BEEN TRYING FOR HOURS TO GET SOME ACTION SHOTS OF A BEAR THAT PREFERRED TO SLEEP IN ITS CAGE. "WHAT KIND OF BEAR IS THAT?" HE FINALLY ASKED THE ZOO KEEPER. "HIMALAYAN," WAS THE REPLY. "I KNOW THAT," SNARLED THE PHOTOGRAPHER. "WHAT I WANT TO KNOW IS WHEN HIM A GETTING UP."



## COUPLERS AND PLUGS



### AUTOMOTIVE STANDARD

INTERCHANGE WITH TRU-FLATE 10 AND 100 TYPE. PLATED STEEL COUPLERS HAVE HARDENED STEEL BALLS AND STAINLESS STEEL SPRINGS. BRASS COUPLERS HAVE STAINLESS STEEL BALLS AND SPRINGS. PACKED 10 TO A BOX. WORKING PRESSURE 300 PSI.



STYLE A - MALE THREAD COUPLING & PLUG

#### STYLE A - 3/8" SERIES

MALE NPT	COUPLERS		PLUGS	
	PLATED STEEL	BRASS	PLATED STEEL	BRASS
1/4"	-	-	AMCP7	-
3/8"	-	-	AMCP5	-
1/2"	-	-	-	-

#### STYLE A - 1/2" SERIES

MALE NPT	COUPLERS		PLUGS	
	PLATED STEEL	BRASS	PLATED STEEL	BRASS
3/8"	C903	-	AMCP903	-
1/2"	AMC9	-	AMCP9	-
3/4"	-	-	-	-



STYLE B - FEMALE THREAD COUPLING & PLUG

#### STYLE B - 3/8" SERIES

FEMALE NPT	COUPLERS		PLUGS	
	PLATED STEEL	BRASS	PLATED STEEL	BRASS
1/4"	-	-	-	-
3/8"	AMC6	-	AMCP6	-
1/2"	-	-	-	-

#### STYLE B - 1/2" SERIES

FEMALE NPT	COUPLERS		PLUGS	
	PLATED STEEL	BRASS	PLATED STEEL	BRASS
3/8"	-	-	-	-
1/2"	AMC10	-	AMCP10	-
3/4"	-	-	-	-

### LINCOLN



STYLE A - MALE THREAD COUPLING & PLUG

#### LINCOLN STYLE A - 1/4" SERIES

MALE NPT	COUPLERS	PLUGS
	PLATED STEEL	PLATED STEEL
1/8"	-	-
1/4"	-	AMCP27



STYLE B - FEMALE THREAD COUPLING & PLUG

#### LINCOLN STYLE B - 1/4" SERIES

FEMALE NPT	COUPLERS	PLUGS
	PLATED STEEL	PLATED STEEL
1/4"	AMC28	AMCP28

### ARO SPEED



STYLE A - MALE THREAD COUPLING & PLUG

#### ARO STYLE A - 1/4" SERIES

MALE NPT	COUPLERS	PLUGS
	PLATED STEEL	PLATED STEEL
1/8"	-	-
1/4"	-	AMCP37
3/8"	-	-



STYLE B - FEMALE THREAD COUPLING & PLUG

#### ARO STYLE B - 1/4" SERIES

FEMALE NPT	COUPLERS	PLUGS
	PLATED STEEL	PLATED STEEL
1/4"	AMC38	AMCP38
3/8"	-	-

### UNIVERSAL CROWFOOT COUPLINGS DUCTILE IRON-PLATED



HOSE END - PART HE

STOCK NO.	SIZE
-	3/8"
AMP0002	1/2"
AMP0003	3/4"
AMP0004	1"



FEMALE NPT - PART FE

STOCK NO.	SIZE
-	1/4"
-	3/8"
AMP0007	1/2"
AMP0008	3/4"
AMP0009	1"



MALE NPT - PART ME

STOCK NO.	SIZE
-	1/4"
-	3/8"
AMP0012	1/2"
AMP0013	3/4"
AMP0014	1"

### REPLACEMENT GASKET



STOCK NO.	DESCRIPTION
AMP0037	FOR 2-LUG COUPLER

### SAFETY CLIP



STOCK NO.	AMP0041
-----------	---------





FILTERS, REGULATORS AND LUBRICATORS



FILTERS

USED IN COMPRESSED AIR SYSTEMS TO PROTECT AIR TOOLS AND OTHER EQUIPMENT BY REMOVING MOST LIQUID AND SOLID PARTICLES FROM THE COMPRESSED AIR SYSTEM. THEY ARE DESIGNED FOR GENERAL APPLICATION WHERE EFFECTIVE FILTRATION AND LARGE FLOW CAPACITY ARE REQUIRED.

FEATURES:

- CLEANABLE DEPTH-TYPE ELEMENT HAS EXTRA LARGE SURFACE AREA FOR LONG SERVICE LIFE.
- CAN BE DISASSEMBLED FOR CLEANING WITHOUT REMOVAL FROM THE AIR LINE.
- TRANSPARENT BOWL - 150 PSIG MAX. INLET PRESSURE
- METAL BOWL - 250 PSIG MAX. INLET PRESSURE.
- TRANSPARENT BOWL - 125°F MAX. TEMP. METAL BOWL - 175°F MAX. TEMP.



METAL BOWL	STOCK NO.	PORT SIZE PTF
	TRANS. POLY. BOWL	
	AM4010A	1/4"
	AM4020A	3/8"
	AM4030	1/2"
AM4041		3/4"
AM4050		1"

FILTER MOUNTING BRACKETS

STOCK NO.	SIZE	FITS FILTERS
AM2071A	1/4	4010A, 4020A
AM4772	1/2	4030
AM2090	1"	4041, 4050

REGULATORS

USED IN COMPRESSED AIR SYSTEMS TO MAINTAIN A NEARLY CONSTANT OUTLET PRESSURE DESPITE CHANGES IN INLET PRESSURE.

FEATURES:

- FULL FLOW GAUGE PORTS.
- EASY HAND ADJUSTMENT KNOB HAS INTEGRAL LOCKING DEVICE WHICH CAN BE MADE TAMPER RESISTANT WITH ADDITION OF OPTIONAL SEAL WIRE.
- WALL MOUNTING BRACKET AVAILABLE.
- ACCURATE AND QUICK RESPONSE TO FLOW DEMANDS AND LINE PRESSURE CHANGES.
- BALANCED VALVE DESIGN MINIMIZES EFFECT OF VARIATIONS IN PRIMARY PRESSURE ON SECONDARY PRESSURE.
- OUTLET PRESSURE CAN BE REDUCED EVEN THOUGH THE SYSTEM IS DEAD-ENDED.
- EASILY DISASSEMBLED FOR SERVICING WITHOUT REMOVAL FROM AIR LINE.
- 300 PSIG MAX. INLET PRESSURE.
- MINIATURE: 0°-150°F TEMP. RANGE ALL OTHERS: 0°-175°F.



T-HANDLE	STOCK NO.	PORT SIZE PTF
	KNOB ADJ.	
	AM4100 (MINI)	1/4"
AM4115A		1/4"
AM4125A		3/8"
AM4135		1/2"
AM4141		3/4"
AMR74G6ATRS (H.D.)		3/4"
AM4155		1"

REGULATOR MOUNTING BRACKETS

STOCK NO.	SIZE	FITS REGULATORS
AM4160	MINI	MINI
AM4162A	1/4	4115A, 4125A
AM4772	1/2	4135
AM4165	1"	4141, 4155

LUBRICATORS

MICRO-FOG LUBRICATORS ARE USED IN INDUSTRIAL COMPRESSED AIR SYSTEMS TO LUBRICATE AIR TOOLS, CYLINDERS, VALVES, AIR MOTORS OR OTHER AIR-DRIVEN DEVICES. THEY INJECT A FINELY DIVIDED "FOG" OF OIL INTO THE AIR STREAM AND CAN BE USED IN SYSTEMS CONTAINING COMPLEX PIPING OR MULTIPLE POINTS OF LUBRICATION.

FEATURES:

- FLOW SENSOR DESIGN PROVIDES A NEARLY CONSTANT OIL/AIR RATIO OVER A WIDE RANGE OF AIR FLOWS.
- SIMPLE, KNOB TYPE, OIL-FEED CONTROL WITH INTEGRAL SIGHT-FEED DOME PERMITS FINE ADJUSTMENTS OF OIL-FEED RATE TO PROVIDE THE PROPER DEGREE OF LUBRICATION AT THE POINT OF NEED.
- FINAL OIL-FEED ADJUSTMENT IS EASILY LOCKED WITH INTEGRAL PUSH-PULL LOCKING RING ON THE CONTROL KNOB.
- TRANSPARENT BOWL MAXIMUM INLET PRESSURE: 150 PSIG
- TRANSPARENT BOWL MAXIMUM TEMP: 125°F.
- RECOMMENDED LUBRICANTS: USE A MISTING TYPE OIL RATED 50 TO 200 SSU (ISO GRADE 7 TO 46) AT 100°F.
- TRANSPARENT BOWL WITH DRAIN



STOCK NO.	PORT SIZE PTF	BOWL SIZE
AM4215A	1/4"	1/3 PT.
AM4225A	3/8"	1/3 PT.
AM4235	1/2"	1/2 PT.
AM4245	3/4"	1/2 PT.

LUBRICATOR MOUNTING BRACKETS

STOCK NO.	SIZE	FITS LUBRICATORS
AM2071A	1/4	4215A, 4225A
AM4772	1/2	4235, 4245

## AIRLINE HOSE, HOSE CLAMPS & ACCESSORIES

### AIRLINE HOSE



**SOLD BY THE FOOT**

STOCK NO.	I.D.	WORKING PRESSURE
SI38225	1/4	300 PSI
SI38245	3/8	300 PSI
SI38260	1/2	300 PSI
SI39712	3/4	300 PSI
SI38287	1"	300 PSI

### AIRLINE HOSE ASSEMBLIES



ALL ENDS ARE 1/4" NPT MALE. OTHER SIZES, LENGTHS AND COMBINATIONS AVAILABLE UPON REQUEST.

STOCK NO.	I.D.	LENGTH	WORKING PRESSURE
SIA05	1/4	25'	300 PSI
SIA06	1/4	50'	300 PSI
SIA15	3/8	25'	300 PSI
SIA16	3/8	50'	300 PSI

### AIR BRAKE TUBING

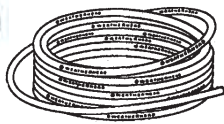

NYLON INNER TUBE WITH OPEN PLY NYLON FIBER REINFORCEMENT AND NYLON COVER. -40°F TO +200°F TEMPERATURE RANGE. 150 P.S.I. MAX PRESSURE.

STOCK NO.	HOSE I.D.
MID38952	1/4
MID38960	3/8
MID38965	1/2

### HEATER HOSE



HEAVY DUTY, THERMAL RED, 3 PLY.

STOCK NO.	SIZE
APHD58	5/8"
APHD34	3/4"

### RETRACTABLE HOSE REELS



LOW VOLUME HOSE REEL FOR AIR APPLICATIONS, WATER AND ANTI-FREEZE. 300 PSI OPERATING PRESSURE. 3/8" HOSE ID. 35 FT. LENGTH.  
**STOCK NO. HTLB335**

LOW PRESSURE STANDARD HOSE REEL FOR AIR, WATER AND LIGHT OILS. 300 PSI OPERATING PRESSURE. 3/8" HOSE ID. 50 FT. LENGTH.  
**STOCK NO. HTLC350**

### STANDARD HOSE CLAMPS



STANDARD HOSE CLAMPS EACH CONSIST OF A STAINLESS STEEL BAND, PLUS A CARBON SCREW AND HOUSING.

**CLAMP NUMBER INCLUDED IN STOCK NUMBER.**

STOCK NO.	DIAMETER RANGE	HOSE I.D.
APM4H*	7/32 - 5/8	3/16 - 5/16
APM6H*	5/16 - 7/8	1/4 - 3/8
APB6H	3/8 - 7/8	1/4 - 3/8
MUH8	7/16 - 1"	5/16 - 1/2
APB10H	1/2 - 1-1/16	3/8 - 5/8
APB12H	1/2 - 1-1/4	5/8 - 3/4
APB16H	3/4 - 1-1/2	3/4 - 7/8
APB20H	3/4 - 1-3/4	1" - 1-1/4
APB24H	1" - 2"	7/8 - 1-3/8
APB28H	1-5/16 - 2-1/4	1-1/4 - 1-5/8
APB32H	1-9/16 - 2-1/2	1-1/2 - 2"
APB36H	7/8 - 2-3/4	1-3/4 - 2-1/4
MUH40	1-1/8 - 3"	2" - 2-1/2
MUH44	2-1/3 - 3-1/4	1-1/4 - 2-1/2
MUH48	2-9/16 - 3-1/2	1-1/2 - 2-3/4
MUH52	2-13/16 - 3-3/4	1-1/4 - 3"
MUH56	3-1/16 - 4"	2" - 3"
MUH60	3-5/16 - 4-1/4	3-1/2 - 4"
MUH64	3-9/16 - 4-1/2	2-1/2 - 3-1/2
MUH72	4-1/16 - 5"	3" - 4"
MUH80	4-5/8 - 5-1/2	4-1/2 - 5"
MUH88	4-3/32 - 6"	5" - 5-1/2
MUH96	4-1/2 - 6-1/2	5-1/2 - 6"
MUH104	5" - 7"	4" - 6-1/2
MUH128	5-1/2 - 8-1/2	7-1/2 - 8"
MUH152	7" - 10"	9" - 9-1/2
MUH188	9-1/2 - 12-1/2	11-1/2 - 12"

\*MINI-CLAMP, 1/4" BAND WIDTH

### 2-EAR OETIKER CLAMP



STOCK NO.	I.D. SIZE	RANGE (INCHES)
MID32616	1/4	.197 - .276
MID32617	5/16	.276 - .354
MID32618	3/8	.315 - .433
MID32620	1/2	.433 - .512
MID32621	9/16	.512 - .591
MID32623	5/8	.591 - .708
MID32624	3/4	.669 - .787
MID32626	7/8	.787 - .905

### OETIKER CLAMP PLIERS



**STOCK NO. MID32686**

### STAINLESS STEEL HOSE CLAMPS

BAND, HOUSING AND SCREW ARE ALL STAINLESS STEEL. NON-MAGNETIC. 1/2" BANDWIDTH.

STOCK NO.	DIAMETER RANGE	HOSE I.D.
WASSM4*	7/32 - 5/8	3/16 - 5/16
WASSM6*	5/16 - 7/8	1/4 - 3/8
WASS6	3/8 - 7/8	1/4 - 3/8
WASS8	7/16 - 1"	5/16 - 1/2
WASS10	9/16 - 1-1/16	3/8 - 5/8
WASS12	9/16 - 1-1/4	5/8 - 3/4
WASS16	11/16 - 1-1/2	3/4 - 1"
WASS20	3/4 - 1-3/4	1" - 1-1/4
WASS24	1-1/16 - 2"	1-1/4 - 1-1/2
WASS28	1-5/16 - 2-1/4	1-1/4 - 1-3/4
WASS32	1-9/16 - 2-1/2	1-1/2 - 2"
WASS36	1-13/16 - 2-3/4	1-3/4 - 2-1/4
WASS40	2-1/16 - 3"	2" - 2-1/2
WASS44	2-5/16 - 3-1/4	2-1/4 - 2-3/4
WASS48	2-9/16 - 3-1/2	2-1/2 - 3"
WASS52	2-13/16 - 3-3/4	3" - 3-1/4
WASS56	3-1/16 - 4"	3-1/4 - 3-1/2
WASS60	3-5/16 - 4-1/4	3-1/2 - 4"
WASS80	4-5/8 - 5-1/2	4-1/2 - 5"

\*MINI-CLAMP, 1/4" BAND WIDTH

### CLAMP KIT



A "FIX-IT-KIT" THAT MAKES ANY SIZE CLAMP FROM 2" TO 22" IN DIAMETER. CUT DESIRED LENGTH OF BAND, INSERT CLAMP HOUSING AND INSTALL. BAND AND FASTENERS ARE STAINLESS STEEL. KIT INCLUDES 50 FT.

BAND, 20 ADJUSTABLE FASTENERS AND 10 BAND SPLICES.

**STOCK NO. WAS4002**

BOX OF 20 ADJUSTABLE FASTENERS  
**STOCK NO. WAS4004**

BOX OF 10 BAND SPLICES  
**STOCK NO. WAS4008**

### PUNCH LOCK CLAMPS



FOR LESS DEMANDING APPLICATIONS WHERE MINIMIZING LEAKS AND LONGEVITY ARE NOT CRITICAL. NOT RECOMMENDED FOR FITTINGS THAT MAY CRACK AS A RESULT OF IMPACT. LOCK WITH IMPACT FROM A HAMMER USING A CONICAL PUNCH. GALVANIZED CARBON STEEL. HAND TOOL CAN BE ORDERED AS NEEDED.

STOCK NO.	HOSE I.D.	CLAMP I.D.
DIXK4	3/4	1"
DIXK7	1"	1-3/4

**SNAP-LOC AIR / LIQUID COOLANT HOSE SYSTEMS**

**HOSE SEGMENTS**

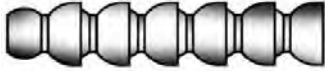

(DARK GRAY STANDARD)

STOCK NO.	SIZE
SL842521	1/4" x 12"
SL845021	1/2" x 12"

**HOSE SEGMENT ADAPTER**



(ADAPTS SNAP-LOC HOSE TO LOC-LINE HOSE)  
(WHITE STANDARD)

STOCK NO.	SIZE
SL8525224	1/4"
- 8550206	1/2"

**ROUND NOZZLES**



(LIGHT GRAY STANDARD)

STOCK NO.	HOSE SIZE	x	NOZZLE SIZE
SL842514	1/4"	x	1/16"
SL842515	1/4"	x	1/8"
SL842516	1/4"	x	1/4"
SL845014	1/2"	x	1/4"
SL845015	1/2"	x	3/8"

**FLARE NOZZLES**

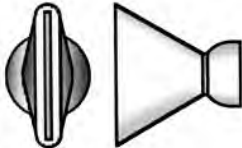

(LIGHT GRAY STANDARD)

STOCK NO.	HOSE SIZE	x	NOZZLE SIZE
SL842519	1/4"	x	1"
SL845019	1/2"	x	2"

**SNAP-LOC SYSTEMS PROVIDE ADJUSTABLE LENGTH AND INTERCHANGEABLE NOZZLE DIAMETERS WITH EASY HAND ASSEMBLY.**

**UN-RESTRICTED FLOW. NO VIBRATION WANDERING. CHEMICALLY-RESISTANT. ELECTRICALLY NON-CONDUCTIVE. 3-DIMENSIONAL FLEXIBILITY AND HOLDING POWER SERVES A WIDE RANGE OF APPLICATIONS.**

**SNAP-LOC**

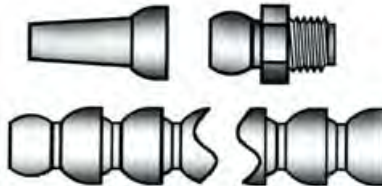

**HOSE ASSEMBLY KITS**

**1/4" SNAP-LOC KIT**  
SET INCLUDES 1/16", 1/8", 1/4" NOZZLES. 1/8", 1/4" NPT CONNECTORS. HOSE ASSEMBLY APPROX. 13".

**STOCK NO. SL842511**

**1/2" SNAP-LOC KIT**  
SET INCLUDES 1/4", 3/8", 1/2" NOZZLES. 3/8", 1/2" NPT CONNECTORS. HOSE ASSEMBLY APPROX. 13".

**STOCK NO. SL845011**

**ADDITIONAL SNAP-LOC ACCESSORIES AND PRODUCTS AVAILABLE UPON REQUEST**



**CONNECTORS**

**MALE HOSE TO MALE PIPE THREAD**

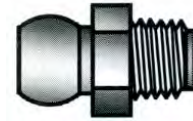

(LIGHT GRAY STANDARD)

STOCK NO.	I.D.	x	NPT SIZE
SL842517	1/4"	x	1/8"
SL842518	1/4"	x	1/4"
SL845017	1/2"	x	3/8"
SL845018	1/2"	x	1/2"

**HOSE TO HOSE "Y"**

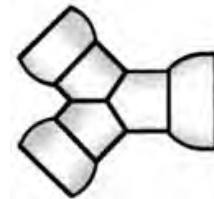

(DARK GRAY STANDARD)

STOCK NO.	SIZE
SL8525100	1/4"
SL8550100	1/2"

**MALE HOSE TO MALE PIPE THREAD "Y"**

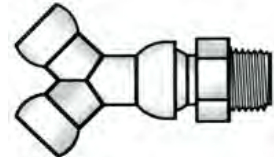

(DARK GRAY STANDARD)

STOCK NO.	I.D.	x	NPT SIZE
SL8525129	1/4"	x	1/4"

**SERVICE YOU CAN DEPEND ON!**

**CAN'T FIND SOMETHING?  
CALL US**

Q: HOW DO YOU GET A MAN TO DO SIT-UPS?

A: PUT THE REMOTE CONTROL BETWEEN HIS FEET.

### V BELTS

WE HAVE ADDED V-BELTS TO ITS GROWING INVENTORY. THE SIZES LISTED BELOW ARE STOCKED NOW, BUT WE ARE LOOKING TO CREATE AND EXPAND OUR MARKET. CHECK WITH US ON YOUR BELT NEEDS.

#### V-BELTS



STOCK NO.	DESCRIPTION
BEL3V400	3V400
BEL5VX1600	5VX1600 COGGED
BELA119	A119
BELA38	A38
BELA42	A42
BELA46	A46
BELA48	A48
BELA51	A51
BELA54	A54
BELB136	B136
BELBX136	BX136 COGGED
BELC83	C83
BELA26	A26
BELB95	B95

#### STANDARD BELT DIMENSIONS

SIZE	TOP WIDTH	THICK
A	1/2"	11/32"
B	21/32"	13/32"
C	7/8"	17/32"
D	1-1/4"	3/4"
E	1-1/2"	1"

#### CLASSICAL BELTS "A-E"

CLASSICAL BELTS ARE MEASURED BY INSIDE LENGTH. IF MEASURING BY OUTSIDE LENGTHS SUBTRACT BY THE FOLLOWING TO DETERMINE CORRECT SIZE.

A - 2" EX.	45 INCHES - 2" = A43
B - 3" EX.	46 INCHES - 3" = B43
C - 4" EX.	47 INCHES - 4" = C43
D - 5" EX.	145 INCHES - 5" = D140
E - 6" EX.	150 INCHES - 6" = E144

#### ACCU-LINK BELTING



DETACHES WITH A SIMPLE TWIST. YOU CAN CREATE ANY LENGTH NEEDED. NO TOOLS NEEDED. IDEAL AS A TEMPORARY REPLACEMENT OR PERMANENT SUBSTITUTE FOR CONVENTIONAL RUBBER V-BELTS. EXCELLENT FOR FIELD OR OFF SITE JOB EMERGENCIES.

STOCK NO.	DESCRIPTION
BELALINK25	A-25 FT.
BELBLINK25	B-25 FT.

#### Installation Instructions

1. Before installing, turn belt inside out and couple the belt.
2. Place endless **Accu-Link® V-belt** in the nearest small sheave groove.
3. Extend belt and place in the nearest large sheave groove.
4. Manually turn the **Accu-Link® V-belt** until it is in the groove all around drive. Do not jog motor.
5. Continue to manually work the belt from groove to groove.
6. Repeat until all grooves are filled.

#### Alternative Installation

1. Form **Accu-Link® V-belt** to the correct pitch length.
2. Move motor forward.
3. Place all belts in position.
4. Move motor back into position while applying correct tension.
5. Secure motor tightly.

#### Belt Length Determination

Lay out pitch length of belt desired. Remove 1 link in every 24 for 3L, A & B section or 1 link in every 20 for C section. Assemble belt.

#### Retensioning

Like all vee belts, **Accu-Link®** may require retensioning after 1-3 hours of running.



#### STANDARD TIMING BELT



#### DOUBLE SIDED TIMING BELT



#### CLASSICAL BANDED V-BELT



#### VARIABLE SPEED V-BELT



#### MULTI RIB V-BELT



#### HIGH TORQUE BELT



**PRESSURE GAUGES**

**ECONOMY PRESSURE GAUGES**

BLACK STEEL CASE. GLASS WINDOW. BLACK ALUMINUM POINTER. BRASS INTERNALS.

STOCK NO.	DIAL DIA.	PSI	NPT CONNECT	MOUNT
DAS100	2"	30	1/4	BM
DAS102	2"	60	1/4	BM
DAS104	2"	100	1/4	BM
DAS106	2"	100	1/4	LM
DAS116	2"	200	1/4	BM
DAS118	2"	200	1/4	LM
DAS306	1-1/2"	200	1/8	BM
DAS326	2"	30	1/4	LM
DAS329	2"	60	1/4	LM
DAS345	2"	160	1/4	LM
DAS360	2-1/2"	15	1/4	LM
DAS363	2-1/2"	30	1/4	LM

ADDITIONAL GAUGES AVAILABLE  
UPON REQUEST

**LOWER MOUNT (LM)**



**BACK MOUNT (BM)**



ADDITIONAL TYPES AND STYLES OF PRESSURE  
GAUGES AVAILABLE UPON REQUEST

**PREMIUM LIQUID-FILLED  
PRESSURE GAUGES**

TYPE 304 STAINLESS STEEL CASE. ACRYLIC WINDOW. BLACK ALUMINUM POINTER. BRASS INTERNALS. 100% GLYCERIN FILL.

STOCK NO.	DIAL DIA.	PSI	NPT CONNECT	MOUNT
DAS599	2-1/2"	15	1/4	LM
DAS600	2-1/2"	30	1/4	LM
DAS601	2-1/2"	60	1/4	LM
DAS602	2-1/2"	100	1/4	LM
DAS615	2-1/2"	100	1/4	BM
DAS603	2-1/2"	160	1/4	LM
DAS604	2-1/2"	200	1/4	LM
DAS605	2-1/2"	300	1/4	LM
DAS606	2-1/2"	600	1/4	LM
DAS607	2-1/2"	1500	1/4	LM
DAS608	2-1/2"	2000	1/4	LM
DAS609	2-1/2"	3000	1/4	LM
DAS610	2-1/2"	5000	1/4	LM

**VACUUM GAUGES**

STOCK NO.	DIAL DIA.	IN./HG	NPT CONNECT	MOUNT
DAS504	2"	30-0"	1/4	LM

**PRICES  
AND  
COMPLETE  
INFORMATION  
AVAILABLE  
UPON  
REQUEST**

**OUR COURTEOUS AND  
KNOWLEDGEABLE STAFF IS  
READY TO TAKE CARE OF YOUR ORDER.  
PLEASE CALL NOW.**

**LET OUR INVENTORY  
SERVE AS  
YOUR INVENTORY**

## BRASS FITTINGS

### AIR LINE HOSE BARBS

#### HOSE MENDER/SPLICER



STOCK NO.	TYPE	HOSE I.D.
COR1382	BRASS	1/8
COR1384	BRASS	1/4
COR1385	BRASS	5/16
COR1386	BRASS	3/8
COR1388	BRASS	1/2
COR13810	BRASS	5/8
COR13812	BRASS	3/4
MID973962	STEEL	1"
973903	STEEL	1-1/4
MID973904	STEEL	1-1/2
MID973905	STEEL	2"

#### MALE HOSE BARB



STOCK NO.	HOSE I.D.	PIPE THREAD
COR13922	1/8	1/8
MID32027	1/8	1/4
COR13932	3/16	1/8
COR13942	1/4	1/8
COR13944	1/4	1/4
COR13946	1/4	3/8
COR13954	5/16	1/4
COR13962	3/8	1/8
COR13964	3/8	1/4
COR13966	3/8	3/8
COR13968	3/8	1/2
COR139612	3/8	3/4
COR13984	1/2	1/4
COR13986	1/2	3/8
COR13988	1/2	1/2
COR139812	1/2	3/4
COR139106	5/8	3/8
COR139108	5/8	1/2
COR139128	3/4	1/2
COR1391212	3/4	3/4
COR1391612	1"	3/4
COR1391616	1"	1"

#### SOLID FEMALE HOSE BARB



STOCK NO.	HOSE I.D.	PIPE THREAD
COR14444	1/4	1/4
COR14464	3/8	1/4
COR14466	3/8	3/8

### SWIVEL FEMALE HOSE BARB BALL SEAT



STOCK NO.	HOSE I.D.	PIPE THREAD
COR14344	1/4	1/4
COR14354	5/16	1/4
COR14364	3/8	1/4
COR14366	3/8	3/8

#### MALE 90° ELBOW



STOCK NO.	HOSE I.D.	PIPE THREAD
COR14642	1/4	1/8
COR14644	1/4	1/4
COR14662	3/8	1/8
COR14664	3/8	1/4
COR14666	3/8	3/8
MID32047	3/8	1/2
COR14684	1/2	1/4
COR14686	1/2	3/8
COR146106	5/8	3/8
COR146108	5/8	1/2

#### SWIVEL HOSE BARB



STOCK NO.	HOSE I.D.	PIPE THREAD
32200	1/4	1/4
MID32201	3/8	1/4
MID32202	3/8	3/8
MID32355	1/2	3/8
MID32356	1/2	1/2

### LARGE BRASS/STEEL MALE ADAPTERS



STOCK NO.	TYPE	HOSE I.D.	PIPE THREAD
WMMAB4	BRASS	1"	1"
WMMAB5	BRASS	1-1/4	1-1/4
WMMAS3	STEEL	3/4	3/4
WMMAS4	STEEL	1"	1"
WMMAS5	STEEL	1-1/4	1-1/4
WMMAS6	STEEL	1-1/2	1-1/2
WMMAS7	STEEL	2"	2"

### AIR HOSE REPAIR FERRULES



STOCK NO.	HOSE I.D.	HOSE O.D.
FV010	1/4	19/32
FV011	3/8	23/32
FV012	1/2	27/32
FV015	5/8	1"
FV013	3/4	1-3/16
FV014	1"	1-1/2

THIS SPACE  
IS RESERVED  
FOR FUTURE  
INVENTORY  
ITEMS.

THIS IS A  
COMPREHENSIVE CATALOG  
OF OUR MAJOR LINES  
AND SERVICES,  
BUT IT DOES NOT  
SHOW ALL AVAILABLE  
PRODUCT LINES.  
IF THERE IS SOMETHING YOU  
NEED THAT IS NOT SHOWN,  
WE EITHER CARRY IT  
OR CAN GET IT.

PLEASE CALL US FOR  
INFORMATION.

**BRASS FITTINGS**

**GROUND KEY SHUT-OFF COCKS**

SHUT-OFF COCKS ARE MANUFACTURED FOR USE WITH LOW-PRESSURE AIR, WATER, GAS AND FLUIDS. DESIGNED TO WITHSTAND WORKING PRESSURES OF 30 p.s.i.

**GROUND SEAT DRAIN COCK**



STOCK NO.	PIPE THREAD
COR8402	1/8
COR8404	1/4
COR8406	3/8

**DRAIN COCK- EXTERNAL SEAT**



STOCK NO.	PIPE THREAD
COR8012	1/8
COR8014	1/4

ADDITIONAL ITEMS  
AVAILABLE UPON REQUEST

GIVE US A CALL FOR ALL YOUR  
NEEDS.

**COMPRESSION- BOTH ENDS**

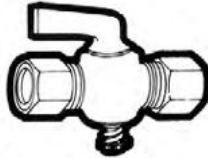

STOCK NO.	TUBING O.D.
COR8624	1/4
COR8625	5/16
COR8626	3/8

**COMPRESSION TO MALE PIPE**

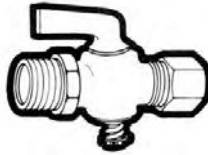

STOCK NO.	TUBING O.D.	PIPE THREAD
COR86842	1/4	1/8
COR86844	1/4	1/4
COR86852	5/16	1/8
COR86854	5/16	1/4
COR86864	3/8	1/4
COR86866	3/8	3/8

QUALITY PRODUCTS, FAIR  
AND COMPETITIVE PRICES,  
AND EXCELLENT SERVICE  
IS OUR REPUTATION

A MAN WENT TO THE MOVIES AND WAS SURPRISED TO FIND A WOMAN WITH A BIG COLLIE SITTING IN FRONT OF HIM. EVEN MORE AMAZING WAS THE FACT THAT THE DOG ALWAYS LAUGHED IN THE RIGHT PLACES THROUGH THE COMEDY.  
"EXCUSE ME," THE MAN SAID TO THE WOMAN, "BUT I THINK IT'S ASTOUNDING THAT YOUR DOG ENJOYS THE MOVIE SO MUCH!"  
"I'M SURPRISED MYSELF," SHE REPLIED. "HE HATED THE BOOK."

**FEMALE PIPE- BOTH ENDS**

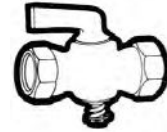

STOCK NO.	PIPE THREAD
COR8752	1/8
COR8754	1/4
COR8756	3/8

**MALE TO FEMALE PIPE**



STOCK NO.	PIPE THREAD
COR8802	1/8
COR8804	1/4
COR8806	3/8

**MINI BALL VALVES**

SOLID CHROME PLATED BRASS BALL. MAX WORKING PRESSURE 235 PSI WITH HANDLE 300 PSI AT 75°. EACH VALVE IS SEAL TESTED FOR MAXIMUM SAFETY. DOUBLE SEAL SYSTEM ALLOWS VALVE TO BE OPERATED IN BOTH DIRECTIONS MAKING INSTALLATION EASIER.

**FEMALE X FEMALE**



STOCK NO.	PIPE THREAD
MID46920I	1/8
MID46922I	1/4
MID46923I	3/8
MID46924I	1/2

**MALE X FEMALE**



STOCK NO.	PIPE THREAD
MID46903I	1/4
MID46904I	3/8
MID46905I	1/2

## BRASS FITTINGS

### BRASS PIPE FITTINGS

USED WITH BRASS, COPPER AND IRON PIPE.  
TYPICAL APPLICATION: WATER, AIR, OIL,  
NATURAL GAS AND LIQUEFIED PETROLEUM  
PRODUCTS.

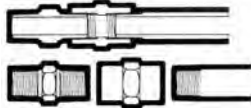

ELBOW



STOCK NO.	PIPE THREAD
COR1002	1/8
COR1004	1/4
COR1006	3/8
COR1008	1/2
COR10012	3/4 (BAR STOCK)
MID44104	3/4 (CAST)

### TEE

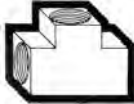

STOCK NO.	PIPE THREAD
COR1012	1/8
COR1014	1/4
COR1016	3/8
COR1018	1/2
10112	3/4 (BAR STOCK)
MID44254	3/4 (CAST)

### CROSS

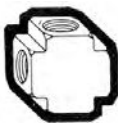

STOCK NO.	PIPE THREAD
COR1024	1/4
COR1026	3/8
COR1028	1/2

### SERVICE TEE MALE PIPE ON RUN

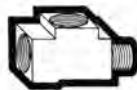

STOCK NO.	PIPE THREAD
COR1272	1/8
COR1274	1/4
COR1276	3/8

### MALE BRANCH TEE



STOCK NO.	PIPE THREAD
COR1284	1/4
COR12812	3/4

### ACTUAL SIZE OF PIPE THREAD

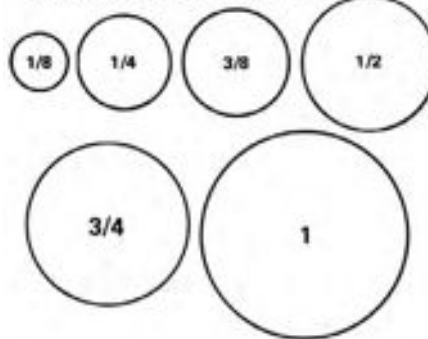

### CAP



STOCK NO.	PIPE THREAD
CORNPT1082	1/8
CORNPT1084	1/4
CORNPT1086	3/8
CORNPT1088	1/2
MID44474	3/4
MID44475	1"

### 90° STREET ELBOW

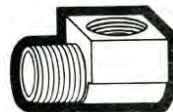

STOCK NO.	PIPE THREAD
COR1162	1/8
COR1164	1/4
COR1166	3/8
COR1168	1/2
COR11612	3/4

### 45° STREET ELBOW



STOCK NO.	PIPE THREAD
COR1242	1/8
COR1244	1/4
COR1246	3/8
COR1248	1/2
COR12412	3/4

### REDUCING HEX NIPPLE



STOCK NO.	PIPE THREAD
COR12342	1/4 x 1/8
12362	3/8 x 1/8
COR12364	3/8 x 1/4
12384	1/2 x 1/4
COR12386	1/2 x 3/8
COR123128	3/4 x 1/2

### ADAPTER



STOCK NO.	PIPE THREAD
COR1202	1/8MPT x 1/8FPT
COR1204	1/4MPT x 1/4FPT
COR1206	3/8MPT x 3/8FPT
COR1208	1/2MPT x 1/2FPT

### REDUCING ADAPTER

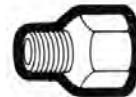

STOCK NO.	PIPE THREAD
COR120R42	1/8MPT x 1/4FPT
COR120R64	1/4MPT x 3/8FPT
COR120R86	3/8MPT x 1/2FPT

### SQUARE HEAD PLUG



STOCK NO.	PIPE THREAD
COR1092	1/8
COR1094	1/4
COR1096	3/8
COR1098	1/2
COR10912	3/4
COR10916	1"
MID44656*	1-1/4

\*BRONZE

### PLUG- RECESSED HEX HEAD



STOCK NO.	PIPE THREAD
COR1182	1/8
COR1184	1/4
COR1186	3/8
COR1188	1/2

### PLUG- HEX HEAD







STOCK NO.	PIPE THREAD
COR1212	1/8
COR1214	1/4
COR1216	3/8
COR1218	1/2
COR12112	3/4

**ADDITIONAL SIZES AVAILABLE UPON REQUEST**



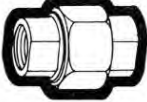

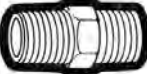

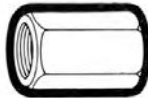
MORE BRASS PIPE FITTINGS ARE CONTINUED  
ON THE NEXT PAGE



**BRASS FITTINGS**

BRASS PIPE FITTINGS (CONTINUED)		NIPPLE			BUSHING	
<p align="center"><b>UNION</b></p>  <p><b>STOCK NO.</b>                      <b>PIPE THREAD</b></p> <p>COR1044*                      1/4                      COR1046*                      3/8                      COR1048*                      1/2                      COR10412*                      3/4                      *BRONZE</p>		 <p><b>STOCK NO.</b>      <b>PIPE THREAD</b>      <b>LENGTH</b></p> <p>COR1122              1/8              CLOSE                      COR113215              1/8              1-1/2                      COR113220              1/8              2"                      COR113225              1/8              2-1/2                      COR113230              1/8              3"                      COR113240              1/8              4"                      COR113250              1/8              5"                      COR1124              1/4              CLOSE                      COR113415              1/4              1-1/2                      COR113420              1/4              2"                      COR113425              1/4              2-1/2                      COR113430              1/4              3"                      COR113435              1/4              3-1/2                      COR113440              1/4              4"                      COR1126              3/8              CLOSE                      COR113615              3/8              1-1/2                      COR113620              3/8              2"                      COR113625              3/8              2-1/2                      COR113630              3/8              3"                      COR113640              3/8              4"                      COR1128              1/2              CLOSE                      COR113815              1/2              1-1/2                      COR113820              1/2              2"                      COR113825              1/2              2-1/2                      COR113830              1/2              3"                      COR113835              1/2              3-1/2                      COR113840              1/2              4"                      COR113850              1/2              5"                      COR113860              1/2              6"                      COR113880              1/2              8"                      COR11212              3/4              CLOSE                      COR1131215              3/4              1-1/2                      COR1131220              3/4              2"                      COR1131225              3/4              2-1/2                      COR1131230              3/4              3"                      COR1131235              3/4              3-1/2                      COR1131240              3/4              4"                      MID40087              3/4              4-1/2                      MID40088              3/4              5"                      MID40089              3/4              5-1/2                      MID40090              3/4              6"</p>			 <p><b>STOCK NO.</b>                      <b>PIPE THREAD</b></p> <p>COR11042                      1/4 x 1/8                      COR11062                      3/8 x 1/8                      COR11064                      3/8 x 1/4                      COR11082                      1/2 x 1/8                      COR11084                      1/2 x 1/4                      COR11086                      1/2 x 3/8                      COR110124                      3/4 x 1/4                      COR110126                      3/4 x 3/8                      COR110128                      3/4 x 1/2                      COR110166                      1" x 3/8                      COR110168                      1" x 1/2                      COR1101612                      1" x 3/4                      MID44517                      1-1/4 x 3/4                      MID44518                      1-1/4 x 1"                      MID44522                      1-1/2 x 3/4                      MID44523                      1-1/2 x 1"                      MID44524                      1-1/2 x 1-1/4</p>	
<p align="center"><b>HEX CLOSE NIPPLE</b></p>  <p><b>STOCK NO.</b>                      <b>PIPE THREAD</b></p> <p>COR1222                      1/8                      COR1224                      1/4                      COR1226                      3/8                      COR1228                      1/2</p>						
<p align="center"><b>REDUCING COUPLING</b></p>  <p><b>STOCK NO.</b>                      <b>PIPE THREAD</b></p> <p>COR1042                      1/4 x 1/8                      COR1064                      3/8 x 1/4                      COR1086                      1/2 x 3/8</p>					<p align="center"><b>COUPLING</b></p>  <p><b>STOCK NO.</b>                      <b>PIPE THREAD</b></p> <p>COR1032                      1/8                      COR1034                      1/4                      COR1036                      3/8                      COR1038                      1/2                      COR10312                      3/4</p>	
<p align="center"><i>ADDITIONAL SIZES AVAILABLE UPON REQUEST</i></p>					<p align="center"><i>ADDITIONAL SIZES AVAILABLE UPON REQUEST</i></p>	

**BRASS GARDEN HOSE ACCESSORIES**

<p align="center"><b>3/4 HOSE CAP</b></p>  <p><b>STOCK NO.</b> MID30104</p>		<p align="center"><b>MALE GARDEN HOSE to MALE PIPE THREAD ADAPTER</b></p>  <p><b>STOCK NO.</b>                      <b>SIZE</b></p> <p>AN78GH                      3/4 x 1/2                      AN79GHT                      3/4 x 3/4</p>		<p align="center"><b>MALE HOSE BARB x FEMALE GARDEN HOSE</b></p>  <p><b>STOCK NO.</b>                      <b>SIZE</b></p> <p>AN29FGH2                      1/2 x 3/4                      AN29FGH3                      5/8 x 3/4                      AN29FGH4                      3/4 x 3/4</p>	
<p align="center"><b>FEMALE CONNECTOR</b></p>  <p><b>STOCK NO.</b> ANS13 (3/4 x 3/4)</p>		<p align="center"><b>MALE HOSE BARB x MALE GARDEN HOSE</b></p>  <p><b>STOCK NO.</b>                      <b>SIZE</b></p> <p>AN29MGH2                      1/2 x 3/4                      AN29MGH3                      5/8 x 3/4                      AN29MGH4                      3/4 x 3/4</p>		<p align="center"><b>3/4 GARDEN HOSE "Y" CONNECTOR</b></p>  <p><b>STOCK NO.</b> AN86GHY12</p>	
<p align="center"><b>RUBBER GARDEN HOSE WASHER</b></p>  <p><b>STOCK NO.</b> ANGHW (3/4)</p>					

### BRASS FITTINGS

#### INVERTED FLARE

##### STANDARD INVERTED NUT



STOCK NO.	TUBING O.D.
COR1053	3/16
COR1053S*	3/16
COR1054S*	1/4

\*STEEL

#### MALE CONNECTOR



STOCK NO.	TUBING O.D.	PIPE THREAD
COR20042	1/4	1/8
COR20044	1/4	1/4

#### MALE ELBOW

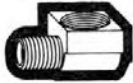

STOCK NO.	TUBING O.D.	PIPE THREAD
COR40042	1/4	1/8
COR40044	1/4	1/4
COR40052	5/16	1/8
COR40064	3/8	1/4
COR40066	3/8	3/8

#### DOUBLE COMPRESSION NUT



ALSO KNOWN AS THREADED SLEEVE

STOCK NO.	TUBING O.D.
COR112	1/8

ADDITIONAL SIZES AVAILABLE UPON REQUEST

**IT IS OUR PLEASURE  
TO SERVE YOU!!**

#### UNION INTERNAL



STOCK NO.	TUBING O.D.
COR3003	3/16
COR3004	1/4
COR3005	5/16

CALL  
FOR COMPLETE  
SPECIFICATIONS  
AND  
PRICES

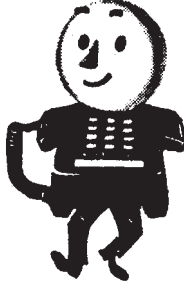

**QUALITY  
PRODUCTS,  
FAIR  
AND  
COMPETITIVE  
PRICES, AND  
EXCELLENT  
SERVICE**



**COPPER, VINYL, POLY, AND METRIC NYLON TUBING**

**METRIC NYLON TUBING**



FLEXIBLE NYLON TUBING CAN BE USED FOR LUBRICATION SYSTEMS, INSTRUMENTATION LINES, FUEL LINES, REFRIGERANT LINES, VACUUM APPLICATIONS, AND FOOD PROCESSING. IT HAS LOW MOISTURE ABSORPTION, GOOD MECHANICAL PROPERTIES, AND EXCELLENT ELECTRICAL PROPERTIES. TEMPERATURE RANGE -10°F TO 225°F. NYLON TUBING ALSO HAS EXCELLENT RESISTANCE TO A WIDE RANGE OF CHEMICALS INCLUDING OILS, GASOLINE, HYDRAULIC FLUIDS, SALT SOLUTIONS, AND BASES.

STOCK NO.	I.D.	O.D.
MID973325	4mm	6mm
MID973327	6mm	8mm
MID973329	8mm	10mm

**CLEAR VINYL TUBING**



CLEAR, FLEXIBLE TUBING IS SUITABLE FOR USE IN LOW PRESSURE APPLICATIONS INCLUDING DRAIN LINES, INDUSTRIAL, CHEMICAL, AGRICULTURAL, AND FOOD AND BEVERAGE APPLICATIONS. HAS GOOD CHEMICAL RESISTANCE TO ALKALIES, AMMONIUM COMPOUNDS, BRINE, AND SOME ACIDS AND ALCOHOLS. SANCTIONED BY THE FDA FOR FOOD PACKING APPLICATIONS. TEMPERATURE RANGE -5°F TO 125°F.

STOCK NO.	I.D.	O.D.
HUD065	1/8	1/4
HUD07	1/4	3/8
HUD075	5/16	7/16
HUD08	3/8	1/2
HUD09	1/2	5/8
HUD10	1/2	3/4
HUD105	5/8	7/8
HUD11	3/4	1"
HUD12	1"	1-1/4"

**POLY TUBING**



LOW DENSITY POLYETHYLENE TUBING HAS A WIDE RANGE OF USES INCLUDING WATER LINES, BEVERAGE TUBING, AIR LINES, INSTRUMENTATION, PLUS USES IN INDUSTRIAL, AGRICULTURAL, AND CHEMICAL APPLICATIONS. HAS GOOD RESISTANCE TO ALKALIES, DILUTE ACID, AMMONIA GAS, AMMONIUM HYDROXIDE, BRINE WATER, AND MOST AQUEOUS SOLUTIONS OF METALLIC SALTS. FOOD GRADE. TEMPERATURE: -40°F TO 135°F.

STOCK NO.	I.D.	O.D.
MID973200	.085	1/8
MID973202	.125	3/16
HUD01	.170	1/4
HUD015	.1875	5/16
HUD02	.250	3/8
HUD03	.375	1/2
HUD04	.500	5/8

**SOFT COPPER TUBING**



STOCK NO.	SIZE
CT01	1/8
CT02	3/16
CT03	1/4
CT04	5/16
CT05	3/8
CT06	1/2
CT07	5/8
CT08	3/4

**YOUR SOURCE FOR INDUSTRIAL SUPPLIES**

SAVE TIME AND MONEY. TO SAVE OUR CUSTOMERS THE DELAY AND BOTHER OF HUNTING THROUGH MANY SOURCES OF SUPPLY, WE CAN FURNISH MANY ITEMS NOT LISTED IN THIS CATALOG.

### BRASS FITTINGS

#### 45° FLARE FITTINGS

USED WITH COPPER, BRASS, ALUMINUM, PLASTIC AND WELDED STEEL HYDRAULIC TUBING THAT CAN BE FLARED. TYPICAL APPLICATIONS: FUEL, OIL, AIR, WATER, LP AND NATURAL GAS LINES, REFRIGERATION (EXCEPT WHERE FROST NUTS ARE REQUIRED), HAZARDOUS LIQUIDS OR GASEOUS CHEMICALS

NOT CORROSIVE TO TUBING MATERIAL OR BRASS.

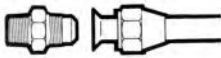
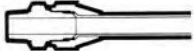

SLIDE NUT ON TUBING. THREADED END OF NUT MUST FACE OUT. FLARE END OF TUBING

WITH A 45° FLARING TOOL. PLACE FLARE END OF TUBING SQUARELY OVER END OF FITTING. HAND ASSEMBLE NUT ONTO FITTING. TIGHTEN SECURELY

#### SHORT NUT



STOCK NO.	TUBING O.D.
COR41S4	1/4
COR41S5	5/16
COR41S6	3/8
COR41S8	1/2
COR41S10	5/8
COR41S12	3/4

#### LONG NUT

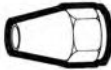

STOCK NO.	TUBING O.D.
COR41L2	1/8
COR41L6	3/8

#### UNION



STOCK NO.	TUBING O.D.
COR422	1/8
COR423	3/16
COR424	1/4
COR425	5/16
COR426	3/8
COR428	1/2
COR42R86*	1/2 x 3/8
COR4210	5/8
COR4212	3/4

\*REDUCING UNION

#### FLARE PLUG



STOCK NO.	TUBING O.D.
COR574	1/4
COR576	3/8
COR578	1/2

ADDITIONAL SIZES AVAILABLE UPON REQUEST

#### MALE ELBOW



STOCK NO.	TUBING O.D.	PIPE THREAD
COR4932	3/16	1/8
COR4942	1/4	1/8
COR4944	1/4	1/4
COR4952	5/16	1/8
COR4954	5/16	1/4
COR4962	3/8	1/8
COR4964	3/8	1/4
COR4966	3/8	3/8
COR4986	1/2	3/8
COR4988	1/2	1/2
COR49106	5/8	3/8
COR49108	5/8	1/2

#### MALE CONNECTOR



STOCK NO.	TUBING O.D.	PIPE THREAD
COR4822	1/8	1/8
COR4842	1/4	1/8
COR4844	1/4	1/4
COR4846	1/4	3/8
COR4848	1/4	1/2
COR4852	5/16	1/8
COR4854	5/16	1/4
COR4856	5/16	3/8
COR4862	3/8	1/8
COR4864	3/8	1/4
COR4866	3/8	3/8
COR4868	3/8	1/2
COR4884	1/2	1/4
COR4886	1/2	3/8
COR4888	1/2	1/2
COR48812	1/2	3/4
COR48106	5/8	3/8
COR48108	5/8	1/2
COR48128	3/4	1/2
COR481212	3/4	3/4

#### FLARE CAP



STOCK NO.	TUBING O.D.
COR564	1/4
COR565	5/16
COR566	3/8
COR568	1/2
COR5610	5/8

#### 45° MALE ELBOW



STOCK NO.	TUBING O.D.	PIPE THREAD
COR4742	1/4	1/8
COR4764	3/8	1/4
COR4786	1/2	3/8
COR47108	5/8	1/2

ADDITIONAL SIZES AVAILABLE UPON REQUEST

#### FLARE TO FLARE ADAPTER

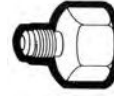

STOCK NO.	TUBING O.D. FEMALE	TUBING O.D. MALE
COR44668	1/2	3/8

#### TEE



STOCK NO.	TUBING O.D.
COR446	3/8

**THIS VALUABLE CATALOG IS YOUR GUIDE TO EFFICIENT BUYING**

**BRASS FITTINGS**

**COMPRESSION FITTINGS**

USED WITH COPPER, BRASS, ALUMINUM AND COPPER TUBING. TYPICAL APPLICATIONS: OIL, GASOLINE, WATER, VACUUM/AIR LINES. WHERE VIBRATION OR MOVEMENT IS NOT INVOLVED.

SLIDE NUT AND THEN SLEEVE ON TUBING. INSERT TUBING INTO FITTING BODY. ASSEMBLE NUT TO FITTING BODY. TIGHTEN NUT COMPRESSING SLEEVE TO CREATE SEAL WITH TUBE.

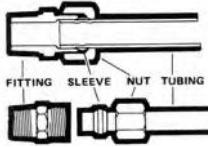

**BRASS INSERT**



STOCK NO.	TUBING I.D.	STOCK NO.	TUBING I.D.
MID22008	.080	MID22010B	.172
MID22009A	.095	CORP615	.187
CORP613	.110	CORP616	.250
MID22010A	.125	CORP6110	.483
MID22009	.135	CORP618	.500
CORP614	.163		

**STANDARD SLEEVE**



STOCK NO.	TUBING O.D.	STOCK NO.	TUBING O.D.
COR602	1/8	COR603	3/16
COR604	1/4	COR605	5/16
COR606	3/8	COR608	1/2
COR6010	5/8	COR6012	3/4

**NUT**



STOCK NO.	TUBING O.D.
COR612	1/8
COR613	3/16
COR614	1/4
COR615	5/16
COR616	3/8
COR618	1/2
COR6110	5/8
COR6112	3/4

**PLASTIC DELRIN SLEEVE**



STOCK NO.	TUBING O.D.
CORP604	1/4
CORP605	5/16
CORP606	3/8
CORP608	1/2

**NPT BRONZE AIR MUFFLER**



STOCK NO.	SIZE
MID300022	1/4
MID300023	3/8
MID300024	1/2

**UNION TEE  
THREE TUBE ENDS**

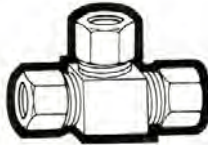

STOCK NO.	TUBING O.D.
COR642	1/8
COR643	3/16
COR644	1/4
COR645	5/16
COR646	3/8
COR648	1/2

**MALE BRANCH TEE**

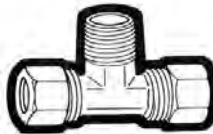

STOCK NO.	TUBING O.D.	PIPE THREAD
COR7232	3/16	1/8
COR7242	1/4	1/8
COR7244	1/4	1/4
COR7262	3/8	1/8
COR7264	3/8	1/4
COR7266	3/8	3/8

**MALE RUN TEE**

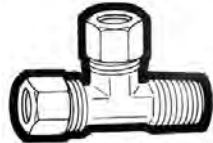

STOCK NO.	TUBING O.D.	PIPE THREAD
COR7142	1/4	1/8
COR7144	1/4	1/4
COR7164	3/8	1/4

**MALE CONNECTOR**

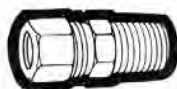

STOCK NO.	TUBING O.D.	PIPE THREAD
COR6822	1/8	1/8
COR6832	3/16	1/8
COR6842	1/4	1/8
COR6844	1/4	1/4
COR6846	1/4	3/8
COR6852	5/16	1/8
COR6854	5/16	1/4
COR6856	5/16	3/8
COR6862	3/8	1/8
COR6864	3/8	1/4
COR6866	3/8	3/8
COR6868	3/8	1/2
COR6884	1/2	1/4
COR6886	1/2	3/8
COR6888	1/2	1/2
COR68108	5/8	1/2
COR68128	3/4	1/2
COR68122	3/4	3/4

**FEMALE CONNECTOR**

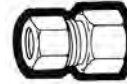

STOCK NO.	TUBING O.D.	PIPE THREAD
COR6632	3/16	1/8
COR6642	1/4	1/8
COR6644	1/4	1/4
COR6662	3/8	1/8
COR6664	3/8	1/4
COR6666	3/8	3/8
COR6688	1/2	1/2

**UNION**

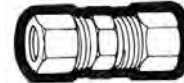

STOCK NO.	TUBING O.D.
COR622	1/8
COR623	3/16
COR624	1/4
COR625	5/16
COR626	3/8
COR628	1/2
COR6210	5/8
COR6212	3/4

**MALE ELBOW**



STOCK NO.	TUBING O.D.	PIPE THREAD
COR6922	1/8	1/8
COR6932	3/16	1/8
COR6942	1/4	1/8
COR6944	1/4	1/4
COR6946	1/4	3/8
COR6952	5/16	1/8
COR6954	5/16	1/4
COR6956	5/16	3/8
COR6962	3/8	1/8
COR6964	3/8	1/4
COR6966	3/8	3/8
COR6984	1/2	1/4
COR6986	1/2	3/8
COR6988	1/2	1/2
COR69108	5/8	1/2
COR69128	3/4	1/2
COR691212	3/4	3/4

**FEMALE ELBOW**

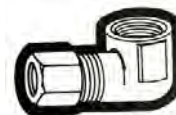

STOCK NO.	TUBING O.D.	PIPE THREAD
COR7042	1/4	1/8
COR7044	1/4	1/4
COR7064	3/8	1/4
COR7084	1/2	1/4

**ADDITIONAL SIZES AVAILABLE UPON REQUEST**

## PUSH-TO-CONNECT TUBE FITTINGS

FOR USE WITH POLYETHYLENE, NYLON, POLY-BUTYLENE AND SOFT METAL TUBING. POSITIVE SEAL WITH NO LEAKS. WORKING TEMPERATURE 10° F. to 200° F.

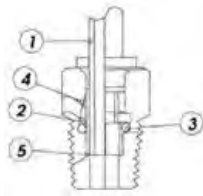

WHEN TUBING (1) IS INSERTED INTO THE FITTING, IT FIRST PASSES THROUGH THE GRIPPING TEETH (2). JUST BEYOND THE GRIPPING TEETH IS THE O-RING (3), WHICH PROVIDES THE LEAK PROOF SEAL AGAINST THE O.D. OF THE TUBE. THE GRIPPING TEETH GRAB THE TUBE, WHICH EXPANDS THE INSERT. PULLING BACK ON THE TUBE ONLY TIGHTENS

THE GRIP AS THE INSERT MOVES ONTO THE CAMMING SURFACE (4). PRESSURE THROUGH THE TUBE ALSO SERVES TO TIGHTEN THE GRIP. THE TUBE BOTTOMS AGAINST A POSITIVE TUBE STOP (5) IN A CAVITY PROVIDING TUBE SUPPORT TO PREVENT LEAKAGE.

(ITEMS WITH AN **MID** PREFIX ARE IN STOCK)

### PLUG



STOCK NO.	TUBING O.D.
-	1/8
20009	5/32
20010	1/4
20011	3/8
20013	1/2

### UNION



STOCK NO.	TUBING O.D.
20017	1/8
20018	5/32
<b>MID20019</b>	1/4
<b>MID20020</b>	3/8
20021	1/2

### UNION TEE



STOCK NO.	TUBING O.D.
20025	1/8
20026	5/32
<b>MID20028</b>	1/4
<b>MID20029</b>	3/8
20030	1/2

**SWIVEL MALE BRANCH TEES AND SWIVEL MALE RUN TEES ARE ALSO AVAILABLE UPON REQUEST**

### UNION ELBOW



STOCK NO.	TUBING O.D.
20150	1/8
20151	5/32
<b>MID20152</b>	1/4
<b>MID20153</b>	3/8
20154	1/2

### FEMALE CONNECTOR



STOCK NO.	TUBING O.D.	PIPE THREAD
20032	1/8	1/8
20033	5/32	1/8
20034	1/4	1/8
20035	1/4	1/4
20036	3/8	1/4
20037	3/8	3/8

### MALE CONNECTOR



STOCK NO.	TUBING O.D.	PIPE THREAD
20047	1/8	10/32*
20048	1/8	1/8
<b>MID685321</b>	5/32	1/16
20049	5/32	10/32*
<b>MID20050</b>	5/32	1/8
20046	5/32	1/4
20053	1/4	10/32*
<b>MID20054</b>	1/4	1/8
<b>MID20055</b>	1/4	1/4
<b>MID20056</b>	1/4	3/8
<b>MID20530</b>	5/16	1/8
<b>MID20531</b>	5/16	1/4
20057	3/8	1/8
<b>MID20058</b>	3/8	1/4
<b>MID20059</b>	3/8	3/8
<b>MID20062</b>	3/8	1/2
<b>MID20060</b>	1/2	1/4
<b>MID20061</b>	1/2	3/8
<b>MID20063</b>	1/2	1/2

\*10/32- SUPPLIED WITH GASKETS

### MALE ELBOW



STOCK NO.	TUBING O.D.	PIPE THREAD
20065	1/8	1/8
20066	5/32	1/8
<b>MID20068</b>	1/4	1/8
<b>MID20069</b>	1/4	1/4
20070	1/4	3/8
20071	3/8	1/8
<b>MID20072</b>	3/8	1/4
<b>MID20073</b>	3/8	3/8
20074	1/2	1/4
20075	1/2	3/8

### SWIVEL MALE ELBOW



STOCK NO.	TUBING O.D.	PIPE THREAD
20079	1/8	1/8
<b>MID20076</b>	5/32	10/32*
<b>MID20080</b>	5/32	1/8
20077	5/32	1/4
20078	1/4	10/32*
<b>MID20081</b>	1/4	1/8
<b>MID20082</b>	1/4	1/4
<b>MID20086</b>	1/4	3/8
<b>MID20087</b>	3/8	1/8
<b>MID20083</b>	3/8	1/4
<b>MID20084</b>	3/8	3/8
20088	3/8	1/2
<b>MID20085</b>	1/2	3/8
<b>MID20092</b>	1/2	1/2

\*10/32- SUPPLIED WITH GASKETS

### FEMALE ELBOW



STOCK NO.	TUBING O.D.	PIPE THREAD
20089	1/4	1/8
20090	1/4	1/4
20091	3/8	1/4

### MALE BRANCH TEE



STOCK NO.	TUBING O.D.	PIPE THREAD
20112	1/8	1/8
20113	5/32	1/8
20115	1/4	1/8
<b>MID20106 (SWIVEL)</b>	1/4	1/4
<b>MID20116</b>	1/4	1/4
20117	3/8	1/8
<b>MID20118</b>	3/8	1/4
20119	3/8	3/8
20120	1/2	3/8

### MALE RUN TEE



STOCK NO.	TUBING O.D.	PIPE THREAD
20095	1/8	1/8
20096	5/32	1/8
20098	1/4	1/8
20093	1/4	1/4
20099	3/8	1/8
20100	3/8	1/4
20101	3/8	3/8
20102	1/2	3/8

## NYLON AIR BRAKE COMPRESSION FITTINGS AND BRAKE TUBING

### FITTINGS FOR NYLON AIR BRAKE TUBING

UTILIZES RIBBED SLEEVE FOR COMPRESSION AND POSITIVE GRIP.

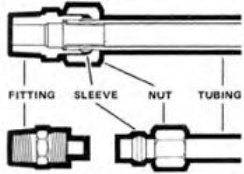

CUT TUBING TO REQUIRED LENGTH. INSERT TUBING INTO FITTING. TIGHTEN NUT.



STOCK NO.	TUBING O.D.
COR4604	1/4
COR4606	3/8
COR4608	1/2
COR46010	5/8

#### NUT



STOCK NO.	TUBING O.D.
COR4614	1/4
COR4616	3/8
COR4618	1/2
COR46110	5/8

#### MALE CONNECTOR



STOCK NO.	TUBING O.D.	PIPE THREAD
COR46842	1/4	1/8
COR46844	1/4	1/4
46846	1/4	3/8
COR46862	3/8	1/8
COR46864	3/8	1/4
COR46866	3/8	3/8
COR46884	1/2	1/4
COR46886	1/2	3/8
COR46888	1/2	1/2
COR468106	5/8	3/8
COR468108	5/8	1/2
COR4681012	5/8	3/4
COR468128	3/4	1/2

#### STAINLESS STEEL INSERT



STOCK NO.	TUBING O.D.
MID38035	1/4
MID38036	3/8
MID38037	1/2
MID38038	5/8
MID38039	3/4

#### MALE ELBOW



STOCK NO.	TUBING O.D.	PIPE THREAD
COR46942	1/4	1/8
COR46944	1/4	1/4
COR46946	1/4	3/8
COR46962	3/8	1/8
COR46964	3/8	1/4
COR46966	3/8	3/8
COR46984	1/2	1/4
COR46986	1/2	3/8
COR46988	1/2	1/2

#### 45° MALE ELBOW



STOCK NO.	TUBING O.D.	PIPE THREAD
COR48042	1/4	1/8
COR48044	1/4	1/4
COR48064	3/8	1/4
COR480108	5/8	1/2

#### UNION



STOCK NO.	TUBING O.D.
COR4624	1/4
COR4626	3/8
COR4628	1/2
COR46210	5/8
COR46212	3/4

#### 90° MALE ELBOW

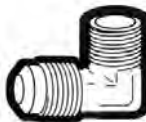

STOCK NO.	TUBING O.D.	PIPE THREAD
COR469106	5/8	3/8
COR469108	5/8	1/2
COR469128	3/4	1/2

#### 3-WAY TEE

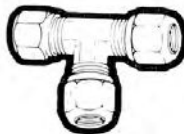

STOCK NO.	TUBING O.D.
COR4644	1/4
COR4646	3/8
COR4648	1/2
COR46410	5/8

### SPLIT SLEEVE COMPRESSION FITTINGS COLLET SLOTTED FERRULE



STOCK NO. COR5602 (1/8)

### COLLET COMPRESSION UNION



STOCK NO. COR5622 (1/8)

ADDITIONAL SIZES AVAILABLE UPON REQUEST

### NYLON AIR BRAKE TUBING

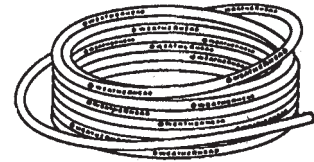

NYLON INNER TUBE WITH OPEN PLY NYLON FIBER REINFORCEMENT AND NYLON COVER. -40°F TO + 200°F TEMPERATURE RANGE. 150 PSI MAXIMUM WORKING PRESSURE.

STOCK NO.	SIZE
MID38952	1/4
MID38960	3/8
MID38965	1/2

### HAVE THE RIGHT FITTING...

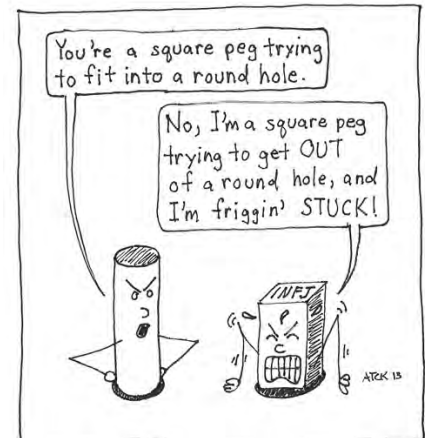

© 2013 Avon T.C. ayres@ckimura

## LUBRICATION GUNS

### HEAVY-DUTY LEVER GREASE GUN



FIRST-CHOICE OF USERS EVERYWHERE. GUN HEAD, TOGGLE AND HANDLE ASSEMBLY ARE CADMIUM-PLATED. 21-3/4" LENGTH. 6" EXTENSION AND GREASE COUPLER INCLUDED. 16 OZ. BULK OR CARTRIDGE.

STOCK NO. LIN1142

### HEAVY-DUTY PRECISION HIGH PRESSURE AND VOLUME GREASE GUN



DESIGNED FOR COMPOUNDED LEVERAGE. ALL-WEATHER USE. GREATER LUBRICANT OUTPUT. EASY OPERATION. 27-1/4" LENGTH. 6" EXTENSION AND HEAVY-DUTY COUPLER INCLUDED. 21 OZ. BULK OR 14 OZ. CARTRIDGE. EQUIPPED WITH FILLER NIPPLE.

STOCK NO. LIN1035

### HEAVY-DUTY, PREMIUM GREASE GUN



HEAVY DUTY, CAST ALLOY HEAD WITH HEAVIER AND REINFORCED WALL THICKNESS FOR EXTRA STRENGTH. DEVELOPS UP TO 10,000 PSI AND BURST PRESSURE OVER 17,500 PSI. HANDY 3-WAY LOADING, STANDARD CARTRIDGE, SUCTION OR BULK FILL. FULLY CHROME PLATED FINISH FOR MAXIMUM PROTECTION AGAINST CORROSION. EQUIPPED WITH AIR BLEEDER VALVE TO RELEASE TRAPPED AIR. INCLUDES FILLER NIPPLE WITH BALL CHECK FOR USE WITH GREASE FILLER PUMP. DELUXE, CONTOURED LEVER HELPS DEVELOP MORE PRESSURE WITH LESS EFFORT. ERGONOMICALLY DESIGNED T-HANDLE PROVIDES POSITIVE GRIP.

STOCK NO. LUMLX1142

### HAND SUCTION GUN



ECONOMY MODEL. CONVENIENT- WILL HOLD UP TO 17 OUNCES OF FLUID LUBRICANT. FLEXIBLE NOZZLE. RUST-RESISTANT. ZINC PLATED.

STOCK NO. LIN610

**ADDITIONAL ITEMS  
AVAILABLE UPON REQUEST**

### PISTOL GRIP GREASE GUN

3-WAY LOADING. VINYL-COVERED PISTOL GRIP. RUGGED DIE CAST HEAD. 18" FLEX HOSE AND GREASE COUPLER. 16 OZ. BULK OR CARTRIDGE.



STOCK NO. LIN1133

### DELUXE PISTOL GRIP GREASE GUN WITH 18" FLEX HOSE



ONE-HAND OPERATION. DEVELOPS UP TO 7,000 PSI. HANDY 3-WAY LOADING STANDARD CARTRIDGE, SUCTION OR BULK FILL. AIR BLEEDER VALVE TO RELEASE TRAPPED AIR. FILLER NIPPLE WITH

BALL CHECK FOR USE WITH GREASE FILLER PUMP. DELUXE, OIL-RESISTANT, CONTOURED GRIP FOR COMFORT AND FIRM GRIP. COMPLETE WITH 4" EXTENSION PIPE, FOUR HARDENED JAWS, HYDRAULIC COUPLER WITH BALL CHECK AND NON-DRIP CAP.

STOCK NO. LUMLX1152

### AIR-POWERED GREASE GUN



PISTOL-TYPE AIR OPERATED GREASE GUN WITH RIGID AND FLEXIBLE EXTENSIONS. 50:1 RATIO WITH AIR INPUT RANGE OF 30-150 PSI. 14 OUNCE CARTRIDGE OR BULK LOADING.

STOCK NO. LIN1163

### FULLY AUTOMATIC, CONTINUOUS CYCLE, AIR OPERATED GREASE GUN



THE ULTIMATE, PROFESSIONAL GREASE GUN. DESIGNED SPECIFICALLY FOR HEAVY DUTY, CONTINUOUS CYCLE USE. ERGONOMICALLY DESIGNED. ONE HAND OPERATION FOR EASY GREASING. WORKING AIR PRESSURE OF 40-150 PSI. PUMP RATIO 40:1. HANDY 3-WAY

LOADING. FULLY CHROME PLATED FINISH FOR MAXIMUM PROTECTION AGAINST CORROSION. INCLUDES FILLER NIPPLE WITH BALL CHECK FOR USE WITH GREASE FILLER PUMP. MAXIMUM OPERATION PRESSURE: 6,000 PSI. POSI-LOCK FOLLOWER ROD WITH ERGONOMICALLY DESIGNED T-HANDLE PROVIDES POSITIVE GRIP AND EASY FILLING AT ANY POSITION. COMPLETE WITH FOUR JAWS HYDRAULIC COUPLER, NON-DRIP CAP, 6" EXTENSION PIPE AND 18: GREASE HOSE WITH SPRING GUARDS.

STOCK NO. LUMLX1161

### DUAL PRESSURE GREASE GUN



VERSATILE TOOL ALLOWS QUICK CHANGE FROM HIGH TO LOW VOLUME PRESSURE. EXTENSION SWIVELS 360°. HANDY 3-WAY LOADING-CARTRIDGE, FILTER PUMP OR BULK. RUBBER HANDLE GRIP. 22-7/8" LENGTH. MAXIMUM PRESSURE 7,000 PSI.

STOCK NO. LIN1013

### HD CORDLESS GREASE GUN



CONTINUOUS OPERATION WITH HIGH PRESSURE DELIVERY. HIGH FLOW RATE. BATTERY PACK RECHARGES IN 1 HOUR. VERSATILE REFILLING WITH 3-WAY LOADING; 14 OZ CARTRIDGE, SUCTION OR WITH A FILLER PUMP. COMPACT DESIGN IN TIGHT SPACES. KIT INCLUDES HIGH CAPACITY, 12 VOLT NiCD RECHARGEABLE BATTERY, 110 VOLT 1-HOUR FAST CHARGER, 3-WAY WRENCH FOR EASY INSTALLATION OR REMOVAL OF HOSE ASSEMBLY, COUPLER AND VALVES, ANTI-FATIGUE CARRYING STRAP AND A HEAVY DUTY SLIM-LINE CARRYING CASE. GREASE CARTRIDGES NOT INCLUDED.

STOCK NO. LUMLX1163

### LITHIUM GREASE



GENERAL AUTOMOTIVE AND INDUSTRIAL GREASE. IDEAL FOR NON-DISC BRAKE WHEEL BEARINGS (DRUMS), CHASSIS AND SUSPENSION. EXCELLENT WATER RESISTANCE. LUBES AT TEMPERATURES RANGING FROM -40°F. TO 320°F. 14 OZ. CARTRIDGE.

STOCK NO. JL31050

**CONSULT CATALOG INDEX  
FOR ADDITIONAL LUBRICANTS**



**LUBRICATION GUN ACCESSORIES**

**GREASE GUN HOSES**

12" FLEXIBLE GREASE GUN HOSE



1/8" NPT MALE ON EACH END - FLEX SPRING

STOCK NO. LIN5812

1/8" NPT MALE ON EACH END



STOCK NO. FV030 (12" FLEX HOSE)

STOCK NO. FV031 (18" FLEX HOSE)

**GREASE GUN CONTROL VALVE**



HEAVY-DUTY, HI-PRESSURE. ALL STEEL HANDLE. PRECISION-CONTROL INLET CHECK VALVE. KNURLED HANDLE FOR POSITIVE GRIP. HANDY TRIGGER GUARD. LUBRICANT INLET 1/4" NPT FEMALE. OUTLET 1/8" NPT FEMALE. MAXIMUM OPERATING PRESSURE 10,000 PSI.

STOCK NO. LIN740

REPAIR PARTS KIT  
STOCK NO. LIN82157

**UNIVERSAL BEARING PACKER**



UNIVERSAL FOR USE ON ALL GREASE GUNS. LIGHTWEIGHT YET, RUGGED CONSTRUCTION. THREADED CENTER POST FOR POSITIVE LOCKING. EASILY LUBRICATES MOST BEARINGS. PRIMES EASILY AND PUMPS EFFICIENTLY WHEN USING HEAVY GREASES AT LOW TEMPERATURES. CAN BE USED WITH EITHER HAND-OPERATED OR POWER LUBE EQUIPMENT. HANDLES BEARINGS FROM 1/2" O.D. TO 5" AND A HEIGHT FROM 1/4" TO 2"

STOCK NO. LUMLX1312

JUST REMEMBER, WHEN YOU'RE OVER THE HILL, YOU BEGIN TO PICK UP SPEED.  
--CHARLES SCHULZ

**GREASE GUN EXTENSION TUBE**



TOUGH, HEAVY-WALL SEAMLESS STEEL TUBING. 1/8" NPT MALE AT EACH END. 6" LENGTH.

STOCK NO. LING906

**GREASE GUN COUPLERS**

1/8" NPT FEMALE - 6000 PSI - SMALL O.D.



STOCK NO. LIN5852

1/8" NPT FEMALE - 7000 PSI - HEAVY-DUTY



STOCK NO. LIN5845

1/8" NPT FEMALE  
SMALL BUTTON HEAD COUPLER



STOCK NO. SWA42030A

*ADDITIONAL ACCESSORIES AVAILABLE  
UPON REQUEST*

**FOR MORE  
INFORMATION  
CALL US**

**GREASE GUN NEEDLE ADAPTER**



FOR CONTACTING HARD-TO-REACH FITTINGS AND FLUSH TYPE FITTINGS.

STOCK NO. LIN82784

**GREASE GUN FILTER NIPPLE**



ENABLES HAND GUNS TO BE LOADING USING FILTER PUMP METHOD. INCLUDES BALL CHECK. 1/8" NPT MALE.

STOCK NO. LIN91108

**360° SWIVEL COUPLER**

1/8" NPT FEMALE. 7000 PSI.



STOCK NO. LIN5848

**GREASE FITTING TOOL**

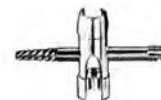

TIGHTENS OR REMOVES BROKEN ALEMITE PIN TYPE FITTINGS, BROKEN FITTINGS AND EVEN RETHREADS CROSSED THREADS. FEATURES INCLUDE A HANDY 1/8" PIPE TAP AND 7/16" & 3/8" SOCKET OPENINGS.

STOCK NO. RIM0051

**QUALITY PRODUCTS, FAIR AND  
COMPETITIVE  
PRICES, AND EXCELLENT  
SERVICE IS OUR REPUTATION**

## GREASE FITTINGS, BARREL PUMPS & FAUCETS, AND DRUM ACCESSORIES

### GREASE FITTING STYLES

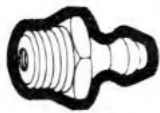

A) STRAIGHT

B) ANGLED

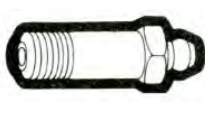

C) FULL ANGLE

D) LONG

STOCK NO.	THREAD	STYLE	TYPE
GF002	1/8" NPT	A	STRAIGHT
GF003	1/8" NPT	D	1-1/4" LONG
GF006	1/8" NPT	B	30° ANGLE
GF007	1/8" NPT	B	45° ANGLE
GF008	1/8" NPT	B	65° ANGLE
GF009	1/8" NPT	C	90° ANGLE
GF004	1/8" NPT	D	1-3/4" LONG

GF101	1/4" NPT	A	STRAIGHT
GF108	1/4" NPT	B	67° ANGLE
GF109	1/4" NPT	C	90° ANGLE
GF201	1/4-28	A	STRAIGHT
GF203	1/4-28	D	15/16" LONG
GF207	1/4-28	B	45° ANGLE
GF209	1/4-28	C	90° ANGLE
GF211	5/16-24	A	STRAIGHT
GF221	3/8-24	A	STRAIGHT

### HIGH PRESSURE/LEAKPROOF FITTINGS

STOCK NO.	THREAD	STYLE	TYPE
GFA040	1/8" NPT	A	STRAIGHT

### DRIVE-TYPE FITTINGS

GF306	3/16"	A	STRAIGHT
GF311	1/4"	A	STRAIGHT
GFA332*	1/4"	A	STRAIGHT
GF316	5/16"	A	STRAIGHT
GF310	3/16"	B	65° ANGLE
GF314	1/4"	B	65° ANGLE

\*NO BALL CHECK

### INSTALLATION TOOL 1/4" STRAIGHT DRIVE FITTINGS



WORKS ON FITTINGS 1952, 608, 728, AND 743

STOCK NO. SWA5253

THERE IS NOTHING IN THE WORLD LIKE A PERSUASIVE SPEECH TO FUDDLE THE MENTAL APPARATUS.

--MARK TWAIN

### BUTTON HEAD GREASE FITTINGS



A) SMALL

B) LARGE

STOCK NO.	THREAD	STYLE	TYPE
GF402	1/8" NPT	A	5/8 DIA.
GF404	1/4" NPT	A	5/8 DIA.
GFA404	1/4" NPT	B	1-1/4" LONG

### 1/8" NPT RELIEF FITTING - 5 PSI



FOR USE ON GEAR BOX HOUSINGS AND BEARINGS (SUCH AS KING PINS, UNIVERSAL JOINTS, ETC), WHERE EXCESSIVE OIL OR LUBRICANT PRESSURES ARE NOT DESIRABLE. THE SAFETY VALVE OPENS AT 5 PSI (RELIEF PRESSURE).

STOCK NO. GFA041

### GREASE FITTING ASSORTMENT



7 ITEMS, 100 PIECES. PLASTIC STORAGE BOX.

CONTENTS: 20 OF 610, 5 OF 612, 5 OF 613, 10 OF 637, 15 OF 638, 45 OF 641, 5 OF 688.

STOCK NO. GF601

### METRIC GREASE FITTING ASSORTMENT



10 ITEMS, 90 PIECES. PLASTIC STORAGE BOX.

CONTENTS: 30 OF 36, 10 OF 37, 10 OF 38, 10 OF 42, 5 OF 43, 5 OF 44, 10 OF 48, 5 OF 49, 5 OF 50.

STOCK NO. GF602

### METRIC GREASE FITTINGS



A) STRAIGHT

B) ANGLED



C) FULL ANGLE

STOCK NO.	THREAD	STYLE	TYPE
GF501	6mm x 1.0	A	STRAIGHT
GF502	6mm x 1.0	B	45° ANGLE
GF503	6mm x 1.0	C	90° ANGLE
GF511	8mm x 1.0	A	STRAIGHT
GF512	8mm x 1.0	B	45° ANGLE
GF513	8mm x 1.0	C	90° ANGLE
GF521	8mm x 1.25	A	STRAIGHT
GF522	8mm x 1.25	B	45° ANGLE
GF523	8mm x 1.25	C	90° ANGLE
GF531	10mm x 1.0	A	STRAIGHT
GF532	10mm x 1.0	B	45° ANGLE
GF533	10mm x 1.0	C	90° ANGLE
GF541	10mm x 1.5	A	STRAIGHT
GF542	10mm x 1.5	B	45° ANGLE
GF543	10mm x 1.5	C	90° ANGLE

### STEEL ADAPTERS

STOCK NO.	THREAD	TYPE
SWA43706	1/8" NPT	90° ELBOW
SWA43748	1/4" NPT	90° ELBOW
SWA43760	1/4" FPT x 1/8" MPT	ADAPTER
SWA51942	1/8" FPT x 1/4-28 M	ADAPTER

### BUTTON HEAD COUPLER

STOCK NO.	THREAD
SWA42030A	1/8" NPT

### HAVE THE RIGHT FITTING...

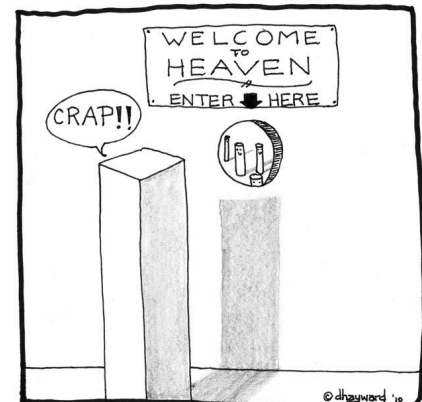

**BARREL PUMPS & ACCESSORIES, LIFTING CLAMPS**

**BARREL PUMPS**



LEVER-ACTION PUMP. STEEL PISTON WITH BRASS PISTON RINGS FOR LONG LIFE AND DURABILITY. NEOPRENE SEALS RESIST WEAR AND ABRASIVE FLUIDS. ZINC-PLATED PUMP AND SPOUT. CURVED DISCHARGE SPOUT WITH GARDEN HOSE THREADS ALLOWS FOR HOSE EXTENSION. 1 PINT PER STROKE. FOR DRUMS WITH 2" OPENINGS.

**STOCK NO. LING401**

PLASTIC BARREL PUMP. FOR USE WITH 30 TO 55 GALLON DRUMS. CONSTRUCTED WITH POLYPROPYLENE TUBE AND NICKEL PLATED STEEL PISTON ROD. WILL PUMP WEAK ACIDS, MILD CHEMICALS, DETERGENT, ANTIFREEZE AND PETROLEUM-BASED PRODUCTS. DISPENSES APPROXIMATELY 8 OZ. PER STROKE.

**STOCK NO. PLEWS55161**

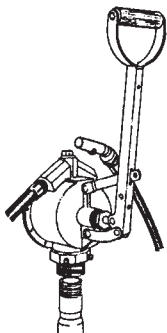

HEAVY-DUTY PUMP. PORTABLE. FOR OILS, GASOLINE AND OTHER APPROVED LIQUIDS. DELIVERS APPROXIMATELY 20 GPM/100 STROKES. LIGHTWEIGHT ALUMINUM DIE-CAST BODY. STAINLESS STEEL INNER LINER. EASY MOUNT 2" TANK ADAPTER, ANTI-SIPHONING DEVICE AND PADLOCKABLE SECURITY CRANK. CORROSION PROOF ADJUSTABLE SUCTION PIPE. STEEL YOKE HANDLE. PUMP MAY BE REVERSED BY ROTATING PISTON 180°. 8' HOSE COMES STANDARD.

**STOCK NO. FILFR152**

**ADDITIONAL DRUM ACCESSORIES  
 AVAILABLE UPON REQUEST**

**DRUM DEHEADER**



SINGLE-LEVER. ALL STEEL CONSTRUCTION. LEAVES A SMOOTH EDGE ON DRUMS. 20" LENGTH.

**STOCK NO. TLDDH**

**DRUM PLUG WRENCH**



BRONZE CONSTRUCTION. LIGHTWEIGHT, NON-SPARKING WRENCH FITS MOST 3/4" AND 2" METAL AND PLASTIC DRUM PLUGS. 10" LENGTH.

**STOCK NO. TLPDW**

**BARREL FAUCETS**



**STOCK NO. ANG261N (3/4" NPT)**



**#75 OIL GATE VALVE**

**STOCK NO. SSC1 (2" NPT)**

**QUESTIONS OR  
 COMMENTS  
 REGARDING  
 THIS CATALOG?**

**DROP US A LINE!**

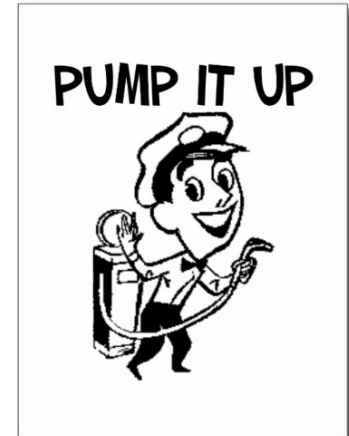

A DESPONDENT WOMAN WAS WALKING ALONG THE BEACH WHEN SHE SAW A BOTTLE ON THE SAND. SHE PICKED IT UP AND PULLED OUT THE CORK. WHOOSH! A BIG PUFF OF SMOKE APPEARED.

"YOU RELEASED ME FROM MY PRISON," THE GENIE TOLD HER. "TO SHOW MY THANKS, I GRANT YOU THREE WISHES. BUT TAKE CARE, FOR WITH EACH WISH, YOUR MATE WILL RECEIVE DOUBLE OF WHATEVER YOU REQUEST."

"WHY?" THE WOMAN ASKED. "THAT BUM LEFT ME FOR ANOTHER WOMAN."

"THAT IS HOW IT IS WRITTEN," REPLIED THE GENIE.

THE WOMAN SHRUGGED AND THEN ASKED FOR A MILLION DOLLARS. THERE WAS A FLASH OF LIGHT, AND A MILLION DOLLARS APPEARED AT HER FEET. AT THE SAME INSTANT, IN A FAR-OFF PLACE, HER WAYWARD HUSBAND LOOKED DOWN TO SEE TWICE THAT AMOUNT AT HIS FEET. "AND YOUR SECOND WISH?"

"GENIE, I WANT THE WORLD'S MOST EXPENSIVE DIAMOND NECKLACE." ANOTHER FLASH OF LIGHT, AND THE WOMAN WAS HOLDING THE PRECIOUS TREASURE. AND, IN THAT DISTANT PLACE, HER HUSBAND WAS LOOKING FOR A GEM BROKER TO BUY HIS LATEST BONANZA.

"GENIE, IS IT REALLY TRUE THAT MY HUSBAND HAS TWO MILLION DOLLARS AND MORE JEWELS THAN I DO, AND THAT HE GET DOUBLE OF WHATEVER I WISH FOR?"

THE GENIE SAID IT WAS INDEED TRUE.

"OKAY, GENIE, I'M READY FOR MY LAST WISH," THE WOMAN SAID. "SCARE ME HALF TO DEATH."

### SCHEDULE 40 PIPE FITTINGS

PIPE NIPPLES		
STOCK NO. (BLACK)	STOCK NO. (GALV.)	SIZE
PF001	PF285	1/8 x CLOSE
PF002	PF286	1/8 x 1-1/2
PF003	PF287	1/8 x 2"
PF004	PF288	1/8 x 2-1/2
PF005	PF289	1/8 x 3"
PF006	PF290	1/8 x 3-1/2
PF007	PF291	1/8 x 4"
PF008	PF292	1/8 x 4-1/2
PF009	PF293	1/8 x 5"
PF010	PF295	1/8 x 6"
PF011	-	1/8 x 7"
PF012	-	1/8 x 8"
-	-	1/8 x 9"
-	-	1/8 x 10"
-	-	1/8 x 11"
-	-	1/8 x 12"
PF017	PF298	1/4 x CLOSE
PF018	PF299	1/4 x 1-1/2
PF019	PF300	1/4 x 2"
PF020	PF301	1/4 x 2-1/2
PF021	PF302	1/4 x 3"
PF022	PF303	1/4 x 3-1/2
PF023	PF304	1/4 x 4"
PF024	-	1/4 x 4-1/2
PF025	PF306	1/4 x 5"
PF026	-	1/4 x 5-1/2
PF027	PF308	1/4 x 6"
PF028	-	1/4 x 7"
PF029	-	1/4 x 8"
-	-	1/4 x 9"
PF031	-	1/4 x 10"
PF032	-	1/4 x 11"
-	-	1/4 x 12"
PF034	PF310	3/8 x CLOSE
PF035	PF311	3/8 x 1-1/2
PF036	PF312	3/8 x 2"
PF037	PF313	3/8 x 2-1/2
PF038	PF314	3/8 x 3"
PF039	PF315	3/8 x 3-1/2
PF040	PF316	3/8 x 4"
PF041	-	3/8 x 4-1/2
PF042	PF318	3/8 x 5"
PF043	-	3/8 x 5-1/2
PF044	-	3/8 x 6"
PF045	-	3/8 x 7"
PF046	-	3/8 x 8"
-	-	3/8 x 9"
PF048	-	3/8 x 10"
-	-	3/8 x 11"
-	-	3/8 x 12"
PF051	PF322	1/2 x CLOSE
PF052	PF323	1/2 x 1-1/2
PF053	PF324	1/2 x 2"
PF054	PF325	1/2 x 2-1/2
PF055	PF326	1/2 x 3"
PF056	PF327	1/2 x 3-1/2
PF057	PF328	1/2 x 4"
PF058	-	1/2 x 4-1/2
PF059	PF330	1/2 x 5"
PF060	-	1/2 x 5-1/2
PF061	PF332	1/2 x 6"
PF062	-	1/2 x 7"
PF063	-	1/2 x 8"
-	-	1/2 x 9"
PF065	PF3325	1/2 x 10"
-	-	1/2 x 11"
PF066	-	1/2 x 12"

(CONTINUED NEXT COLUMN)

PIPE NIPPLES (CONTINUED)		
STOCK NO. (BLACK)	STOCK NO. (GALV.)	SIZE
PF068	PF334	3/4 x CLOSE
PF069	PF335	3/4 x 1-1/2
PF070	PF336	3/4 x 2"
PF071	PF337	3/4 x 2-1/2
PF072	PF338	3/4 x 3"
PF073	PF339	3/4 x 3-1/2
PF074	PF340	3/4 x 4"
PF075	PF341	3/4 x 4-1/2
PF076	PF342	3/4 x 5"
PF077	PF343	3/4 x 5-1/2
PF078	PF344	3/4 x 6"
PF079	-	3/4 x 7"
PF080	PF345	3/4 x 8"
-	-	3/4 x 9"
PF082	PF3451	3/4 x 10"
-	-	3/4 x 11"
PF084	PF3452	3/4 x 12"
PF085	PF346	1" x CLOSE
PF086	PF347	1" x 2"
PF087	PF348	1" x 2-1/2
PF088	PF349	1" x 3"
PF089	PF350	1" x 3-1/2
PF090	PF351	1" x 4"
PF091	PF352	1" x 4-1/2
PF092	PF353	1" x 5"
PF093	PF354	1" x 5-1/2
PF094	PF355	1" x 6"
PF095	-	1" x 7"
PF096	-	1" x 8"
-	-	1" x 9"
PF098	-	1" x 10"
-	-	1" x 11"
-	-	1" x 12"
PF101	PF358	1-1/4 x CLOSE
PF102	PF359	1-1/4 x 2"
PF103	PF360	1-1/4 x 2-1/2
PF104	PF361	1-1/4 x 3"
PF105	-	1-1/4 x 3-1/2
PF106	-	1-1/4 x 4"
PF107	-	1-1/4 x 4-1/2
PF108	-	1-1/4 x 5"
PF109	-	1-1/4 x 5-1/2
PF110	-	1-1/4 x 6"
PF111	-	1-1/4 x 7"
PF112	-	1-1/4 x 8"
-	-	1-1/4 x 9"
-	-	1-1/4 x 10"
PF114	-	1-1/4 x 11"
-	-	1-1/4 x 12"
PF117	PF369	1-1/2 x CLOSE
PF118	-	1-1/2 x 2"
PF119	PF371	1-1/2 x 2-1/2
PF120	PF372	1-1/2 x 3"
PF121	PF373	1-1/2 x 3-1/2
PF122	PF374	1-1/2 x 4"
PF123	-	1-1/2 x 4-1/2
PF124	-	1-1/2 x 5"
PF125	-	1-1/2 x 5-1/2
PF126	-	1-1/2 x 6"
PF127	-	1-1/2 x 7"
PF128	-	1-1/2 x 8"
-	-	1-1/2 x 9"
PF130	-	1-1/2 x 10"
-	-	1-1/2 x 11"
-	-	1-1/2 x 12"

(CONTINUED NEXT COLUMN)

PIPE NIPPLES (CONTINUED)		
STOCK NO. (BLACK)	STOCK NO. (GALV.)	SIZE
PF133	PF380	2 x CLOSE
PF134	PF381	2 x 2-1/2
PF135	PF382	2 x 3
PF136	-	2 x 3-1/2
PF137	PF384	2 x 4
-	-	2 x 4-1/2
PF139	-	2 x 5
-	-	2 x 5-1/2
PF141	-	2 x 6
-	-	2 x 7
PF143	-	2 x 8
PF145	-	2 x 10
PF1452	PF391	2 x 12
PF146	-	2-1/2 x CLOSE
-	-	2-1/2 x 3
PF148	-	2-1/2 x 4
-	-	2-1/2 x 5
PF150	-	2-1/2 x 6

**ADDITIONAL SIZES AVAILABLE UPON REQUEST**

**THREADED PIPE (BLACK ONLY)**

STOCK NO.	SIZE
BP50*	1/8 x 21"
BP51*	1/4 x 21"
BP52*	3/8 x 21"
BP01	1/2 x 18"
BP02	1/2 x 24"
BP03	1/2 x 30"
BP04	1/2 x 36"
BP05	1/2 x 48"
-	1/2 x 60"
BP07	1/2 x 72"
BP53*	1/2 x 21"
BP09	3/4 x 18"
BP10	3/4 x 24"
BP11	3/4 x 30"
BP12	3/4 x 36"
BP13	3/4 x 48"
-	3/4 x 60"
BP15	3/4 x 72"
BP54*	3/4 x 21"
BP17	1" x 18"
BP18	1" x 24"
BP19	1" x 30"
BP20	1" x 36"
BP21	1" x 48"
-	1" x 60"
BP23	1" x 72"
BP55*	1" x 21"
BP25	1-1/4 x 18"
BP26	1-1/4 x 24"
BP27	1-1/4 x 30"
BP28	1-1/4 x 36"
BP29	1-1/4 x 48"
-	1-1/4 x 60"
BP31	1-1/4 x 72"
BP56*	1-1/4 x 21"
-	1-1/2 x 18"
-	1-1/2 x 24"
-	1-1/2 x 30"
-	1-1/2 x 36"
-	1-1/2 x 48"
-	1-1/2 x 60"
BP41	1-1/2 x 72"
BP57*	1-1/2 x 21"
BP58*	2" x 21"

\*THREAD AND COUPLING

**150# MALLEABLE PIPE FITTINGS**

**90 DEGREE ELBOWS**



STOCK NO. (BLACK)	STOCK NO. (GALV.)	SIZE
PF400	-	1/8
PF401	PF511	1/4
PF402	PF512	3/8
PF403	PF513	1/2
PF404	PF514	3/4
PF405	PF515	1"
PF406	PF516	1-1/4
PF407	PF517	1-1/2
PF408	PF518	2"
PF409	-	2-1/2
-	-	3"

**90 DEGREE REDUCING ELBOWS**

STOCK NO. (BLACK)	SIZE
PF40902	3/8 x 1/4
PF40904	1/2 x 3/8
PF40906	3/4 x 1/2
PF40909	1" x 3/4
PF40910	1" x 1/2
PF40912	1-1/4 x 1"
PF40913	1-1/4 x 3/4

**90 DEGREE STREET ELBOWS**



STOCK NO. (BLACK)	STOCK NO. (GALV.)	SIZE
PF451	PF521	1/8
PF452	PF522	1/4
PF453	PF523	3/8
PF454	PF524	1/2
PF455	PF525	3/4
PF456	PF526	1"
PF457	PF527	1-1/4
PF458	PF528	1-1/2
PF459	PF529	2"

**45 DEGREE ELBOWS**



STOCK NO. (BLACK)	STOCK NO. (GALV.)	SIZE
PF470	-	1/8
PF471	-	1/4
PF472	-	3/8

(CONTINUED)

**45 DEGREE ELBOWS**

STOCK NO. (BLACK)	STOCK NO. (GALV.)	SIZE
PF473	-	1/2
PF474	-	3/4
PF475	-	1"
PF476	-	1-1/4
PF477	-	1-1/2
PF478	PF5208	2"
-	-	3"

**45 DEGREE STREET ELBOWS**



STOCK NO. (BLACK)	STOCK NO. (GALV.)	SIZE
-	-	1/8
PF462	-	1/4
PF463	-	3/8
PF464	-	1/2
PF465	-	3/4
PF466	-	1"
PF467	-	1-1/4
PF468	-	1-1/2
PF469	-	2"

**TEES**



STOCK NO. (BLACK)	STOCK NO. (GALV.)	SIZE
PF441	-	1/8
PF442	PF541	1/4
PF443	PF542	3/8
PF444	PF543	1/2
PF445	PF544	3/4
PF446	PF545	1"
PF447	PF546	1-1/4
PF448	PF547	1-1/2
PF449	PF548	2"
PF450	-	2-1/2
-	-	3"

**REDUCING TEES**



STOCK NO. (BLACK)	SIZE
PF45013	1/2 x 1/2 x 3/8
PF45020	3/4 x 3/4 x 1/2
PF45029	1" x 1" x 1/2

(CONTINUED)

**REDUCING TEES**

STOCK NO. (BLACK)	SIZE
PF45030	1" x 1" x 3/4
PF45042	1-1/4 x 1-1/4 x 3/4
PF45043	1-1/4 x 1-1/4 x 1"
PF45056	1-1/2 x 1-1/2 x 3/4
PF45057	1-1/2 x 1-1/2 x 1"
PF45058	1-1/2 x 1-1/2 x 1-1/4

**REDUCING COUPLINGS**



STOCK NO. (BLACK)	STOCK NO. (GALV.)	SIZE
PF479	-	1/4 x 1/8
PF480	-	3/8 x 1/8
PF481	-	3/8 x 1/4
PF482	-	1/2 x 1/8
PF483	-	1/2 x 1/4
PF484	-	1/2 x 3/8
-	-	3/4 x 1/8
PF486	-	3/4 x 1/4
PF487	-	3/4 x 3/8
PF488	-	3/4 x 1/2
PF490	-	1" x 1/4
PF491	-	1" x 3/8
PF492	-	1" x 1/2
PF493	-	1" x 3/4
PF496	-	1-1/4 x 1/2
PF497	-	1-1/4 x 3/4
PF498	-	1-1/4 x 1"
-	-	1-1/2 x 1/2
PF501	-	1-1/2 x 3/4
PF502	-	1-1/2 x 1"
PF503	-	1-1/2 x 1-1/4
PF5034	-	2" x 3/4
PF5035	-	2" x 1"
PF5036	-	2" x 1-1/4
PF5037	-	2" x 1-1/2

**CROSSES**



STOCK NO. (BLACK)	STOCK NO. (GALV.)	SIZE
-	-	1/8
PF431	-	1/4
PF432	-	3/8
PF433	-	1/2
PF434	-	3/4
PF435	-	1"
PF436	-	1-1/4
PF437	-	1-1/2
-	-	2"

## 150# MALLEABLE PIPE FITTINGS

### CAPS



STOCK NO. (BLACK)	STOCK NO. (GALV.)	SIZE
PF410	-	1/8
PF411	PF551	1/4
PF412	PF552	3/8
PF413	PF553	1/2
PF414	PF554	3/4
PF415	PF555	1"
PF416	-	1-1/4
PF417	PF557	1-1/2
PF418	PF558	2"
-	-	2-1/2

### HEX BUSHINGS



STOCK NO. (BLACK)	STOCK NO. (GALV.)	SIZE
PF670	PF710	1/4 x 1/8
PF671	-	3/8 x 1/8
PF672	PF712	3/8 x 1/4
PF673	-	1/2 x 1/8
PF674	PF714	1/2 x 1/4
PF675	PF715	1/2 x 3/8
PF676	-	3/4 x 1/8
PF677	PF717	3/4 x 1/4
PF678	PF718	3/4 x 3/8
PF679	PF719	3/4 x 1/2
PF681	-	1" x 1/4
PF682	-	1" x 3/8
PF683	PF723	1" x 1/2
PF684	PF724	1" x 3/4
PF687	-	1-1/4 x 1/2
PF688	PF727	1-1/4 x 3/4
PF689	PF728	1-1/4 x 1"
-	-	1-1/2 x 3/8
PF692	-	1-1/2 x 1/2
PF693	PF731	1-1/2 x 3/4
PF694	PF732	1-1/2 x 1"
PF695	PF733	1-1/2 x 1-1/4
PF696	-	2" x 1/4
PF697	-	2" x 1/2
PF698	PF735	2" x 3/4
PF699	PF736	2" x 1"
PF700	PF737	2" x 1-1/4
PF701	PF738	2" x 1-1/2
-	-	2-1/2 x 3/4
PF703	-	2-1/2 x 1"
PF704	-	2-1/2 x 1-1/4
PF705	-	2-1/2 x 1-1/2
PF706	-	2-1/2 x 2"
-	-	3" x 1-1/2
PF708	-	3" x 2"

### SQUARE HEAD PLUGS



STOCK NO. (BLACK)	STOCK NO. (GALV.)	SIZE
PF631	-	1/8
PF632	-	1/4
PF633	-	3/8
PF634	PF5604	1/2
PF635	PF5605	3/4
PF636	PF5606	1"
PF637	PF5607	1-1/4
PF638	PF5608	1-1/2
PF639	PF5609	2"
PF640	-	2-1/2
PF641	-	3"
PF642	-	3-1/2
PF643	-	4"

### SQUARE COUNTERSUNK PLUGS



STOCK NO. (BLACK)	STOCK NO. (GALV.)	SIZE
-	-	1/8
-	-	1/4
-	-	3/8
PF656	-	1/2
PF657	-	3/4
-	-	1"
-	-	1-1/4
-	-	1-1/2
-	-	2"
-	-	2-1/2
PF663	-	3"
PF664	-	3-1/2
PF665	-	4"
PF666	-	5"

### HEX COUNTERSUNK PLUGS



STOCK NO. (BLACK)	STOCK NO. (GALV.)	SIZE
PF645*	-	1/16
PF646	-	1/8
PF6451*	-	1/8
PF647	-	1/4
PF6452*	-	1/4
PF648	-	3/8
PF649	-	1/2
PF650	-	3/4
PF6455*	-	3/4
PF651	-	1"
PF652	-	1-1/4
PF653	-	1-1/2
PF654	-	2"

\*ALLOY HEX COUNTERSUNK PLUGS, 7/8 TAPER, "FLUSH STYLE"

### COUPLINGS

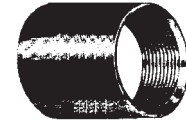

STOCK NO. (BLACK)	STOCK NO. (GALV.)	SIZE
PF600	PF618	1/8
PF601	PF619	1/4
PF602	PF620	3/8
PF603	PF621	1/2
PF604	PF622	3/4
PF605	PF623	1"
PF606	PF624	1-1/4
PF607	PF625	1-1/2
PF608	PF626	2"
PF609	-	2-1/2
-	-	3"
PF6092	-	3-1/2
PF6093	-	4"
PF6095	-	5"

### HALF COUPLINGS



STOCK NO. (BLACK)	STOCK NO. (GALV.)	SIZE
-	-	1/8
-	-	1/4
-	-	3/8
PF612	-	1/2
PF613	-	3/4
PF614	-	1"
PF615	-	1-1/4
PF616	-	1-1/2
-	-	2"
-	-	2-1/2

### UNIONS

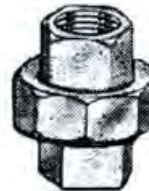

STOCK NO. (BLACK)	STOCK NO. (GALV.)	SIZE
PF419	-	1/8
PF420	-	1/4
PF421	PF532	3/8
PF422	PF533	1/2
PF423	PF534	3/4
PF424	PF535	1"
PF425	PF536	1-1/4
PF426	PF537	1-1/2
PF427	PF538	2"
PF428	-	2-1/2

**SCHEDULE 80 PIPE FITTINGS**

**EXTRA-HEAVY PIPE NIPPLES**



STOCK NO. (BLACK)	SIZE
PF160	1/8 x CLOSE
PF161	1/8 x 1-1/2
PF162	1/8 x 2"
PF163	1/8 x 2-1/2
PF164	1/8 x 3"
PF165	1/8 x 3-1/2
PF166	1/8 x 4"
-	1/8 x 4-1/2
PF168	1/8 x 5"
-	1/8 x 5-1/2
PF170	1/8 x 6"
PF173	1/4 x CLOSE
PF174	1/4 x 1-1/2
PF175	1/4 x 2"
PF176	1/4 x 2-1/2
PF177	1/4 x 3"
PF178	1/4 x 3-1/2
PF179	1/4 x 4"
-	1/4 x 4-1/2
PF181	1/4 x 5"
-	1/4 x 5-1/2
PF183	1/4 x 6"
PF186	3/8 x CLOSE
PF187	3/8 x 1-1/2
PF188	3/8 x 2"
PF189	3/8 x 2-1/2
PF190	3/8 x 3"
PF191	3/8 x 3-1/2
PF192	3/8 x 4"
-	3/8 x 4-1/2
PF194	3/8 x 5"
-	3/8 x 5-1/2
PF196	3/8 x 6"
PF200	1/2 x CLOSE
PF201	1/2 x 1-1/2
PF202	1/2 x 2"
PF203	1/2 x 2-1/2
PF204	1/2 x 3"
PF205	1/2 x 3-1/2
PF206	1/2 x 4"
PF207	1/2 x 4-1/2
PF208	1/2 x 5"
PF209	1/2 x 5-1/2
PF210	1/2 x 6"
-	1/2 x 6-1/2
PF212	1/2 x 7"
PF216	3/4 x CLOSE
PF217	3/4 x 1-1/2
PF218	3/4 x 2"
PF219	3/4 x 2-1/2
PF220	3/4 x 3"
PF221	3/4 x 3-1/2
PF222	3/4 x 4"
PF223	3/4 x 4-1/2
PF224	3/4 x 5"
PF225	3/4 x 5-1/2
PF226	3/4 x 6"
PF230	1" x CLOSE
PF231	1" x 2"
PF232	1" x 2-1/2
PF233	1" x 3"
PF234	1" x 3-1/2
PF235	1" x 4"
PF236	1" x 4-1/2
PF237	1" x 5"
PF238	1" x 5-1/2
PF239	1" x 6"

ADDITIONAL SIZES AVAILABLE UPON REQUEST

**EXTRA-HEAVY PIPE NIPPLES  
(CONTINUED)**

STOCK NO. (BLACK)	SIZE
PF243	1-1/4 x CLOSE
PF244	1-1/4 x 2"
PF245	1-1/4 x 2-1/2
PF246	1-1/4 x 3"
PF247	1-1/4 x 3-1/2
PF248	1-1/4 x 4"
-	1-1/4 x 4-1/2
PF250	1-1/4 x 5"
-	1-1/4 x 5-1/2
PF252	1-1/4 x 6"
PF254	1-1/4 x 10"
PF256	1-1/2 x CLOSE
PF257	1-1/2 x 2"
PF258	1-1/2 x 2-1/2
PF259	1-1/2 x 3"
PF260	1-1/2 x 3-1/2
PF261	1-1/2 x 4"
-	1-1/2 x 4-1/2
PF263	1-1/2 x 5"
-	1-1/2 x 5-1/2
PF265	1-1/2 x 6"
PF269	2" x CLOSE
-	2" x 2-1/2
PF271	2" x 3"
-	2" x 3-1/2
PF273	2" x 4"
-	2" x 4-1/2
PF275	2" x 5"
-	2" x 5-1/2
PF277	2" x 6"

**300 # EXTRA-HEAVY TEES**



STOCK NO.	SIZE
-	1/4
-	3/8
PF583	1/2
PF584	3/4
PF585	1"
PF586	1-1/4
PF587	1-1/2
PF588	2"
-	2-1/2
-	3"

ADDITIONAL SIZES AVAILABLE UPON REQUEST

CALL US WITH YOUR ORDER



**300 # EXTRA-HEAVY UNIONS**

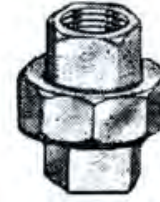

STOCK NO.	SIZE
PF571	1/4
PF572	3/8
PF573	1/2
PF574	3/4
PF575	1"
PF576	1-1/4
PF577	1-1/2
PF578	2"
-	2-1/2
-	3"

**300 # EXTRA-HEAVY  
90 DEGREE ELBOWS**



STOCK NO.	SIZE
PF561	1/4
PF562	3/8
PF563	1/2
PF564	3/4
PF565	1"
PF566	1-1/4
PF567	1-1/2
PF568	2"
-	2-1/2
-	3"

**FLOOR FLANGES**

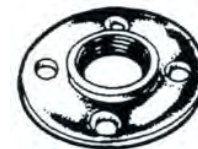

STOCK NO.	SIZE
-	1/8
-	3/8
PF745	1/2
PF746	3/4
PF747	1"
PF748	1-1/4
PF749	1-1/2
PF750	2"

ADDITIONAL SIZES AVAILABLE UPON REQUEST

### FORGED STEEL PIPE FITTINGS

#### F/S 90 DEGREE ELBOWS



STOCK NO. 2000#	STOCK NO. 3000#	STOCK NO. 3000# S.W.	SIZE
PF881	-	-	1/4
PF882	-	-	3/8
PF883	-	PF911	1/2
PF884	-	PF9111	3/4
PF885	PF852	-	1"
PF886	PF853	-	1-1/4
PF887	PF854	PF9114	1-1/2
PF888	PF855	-	2"
-	PF856	-	2-1/2
-	-	-	3"

#### F/S 90 DEGREE STREET ELBOWS



STOCK NO. 3000#	SIZE
PF865	1/4
PF866	3/8
PF867	1/2
PF868	3/4
PF869	1"
PF870	1-1/4
PF871	1-1/2
PF872	2"
-	2-1/2
-	3"

#### F/S HEX BUSHING



STOCK NO.	SIZE
PF796	3/8 x 1/4
PF797	1/2 x 1/4
PF798	1/2 x 3/8
-	3/4 x 1/4
PF800	3/4 x 3/8
PF801	3/4 x 1/2
-	1" x 1/4
-	1" x 3/8
PF803	1" x 1/2
PF804	1" x 3/4
-	1-1/4 x 1/2
PF806	1-1/4 x 3/4
PF807	1-1/4 x 1"
-	1-1/2 x 3/8
PF809	1-1/2 x 1/2
PF810	1-1/2 x 3/4
PF811	1-1/2 x 1"
PF812	1-1/2 x 1-1/4
PF814	2" x 1/2
PF815	2" x 3/4

(CONTINUED)

#### F/S HEX BUSHINGS

STOCK NO.	SIZE
PF816	2" x 1"
PF817	2" x 1-1/4
PF818	2" x 1-1/2
-	2-1/2 x 1"
PF820	2-1/2 x 1-1/4
PF821	2-1/2 x 1-1/2
PF822	2-1/2 x 2"

#### F/S TEES



STOCK NO. 2000#	STOCK NO. 3000#	STOCK NO. 3000# S.W.	SIZE
PF890	-	-	1/4
PF891	-	-	3/8
PF892	-	-	1/2
PF893	PF858	PF9123	3/4
PF894	PF859	PF9124	1"
PF895	PF860	-	1-1/4
PF896	PF861	PF9126	1-1/2
PF897	PF862	-	2"
-	PF863	-	2-1/2
-	-	-	3"

#### F/S CROSSES



STOCK NO. 2000#	SIZE
-	1/4
-	3/8
-	1/2
-	3/4
-	1"
-	1-1/4
PF900	1-1/2
PF901	2"
-	2-1/2
-	3"

#### F/S PLUGS



STOCK NO.	SIZE
PF776	1/4
PF777	3/8
PF778	1/2
PF779	3/4
PF780	1"
PF781	1-1/4
PF782	1-1/2
PF783	2"

#### F/S REDUCING COUPLINGS



STOCK NO. 3000#	SIZE
PF825	3/4 x 3/8
PF830	3/4 x 1/2
PF832	1" x 1/2
PF833	1" x 3/4
PF835	1-1/4 x 3/4
PF836	1-1/4 x 1"
PF838	1-1/2 x 1"
PF839	1-1/2 x 1-1/4
PF841	2" x 1"
PF842	2" x 1-1/4
PF843	2" x 1-1/2
PF845	2-1/2 x 1-1/4
PF846	2-1/2 x 1-1/2
PF847	2-1/2 x 2"

#### SOCKET WELD

STOCK NO. 3000#	SIZE
PF9221	1" x 3/4
PF9234	1-1/2 x 3/4

#### F/S COUPLINGS



STOCK NO. 3000#	STOCK NO. 3000# S.W.	SIZE
PF785	-	1/4
PF786	-	3/8
PF787	-	1/2
PF788	PF9133	3/4
PF789	PF9134	1"
PF790	-	1-1/4
PF791	PF9136	1-1/2
PF792	-	2"
PF793	-	2-1/2
-	-	3"



#### F/S CAPS



STOCK NO. 3000#	SIZE
-	1/4
-	3/8
-	1/2
PF875	3/4
PF876	1"
-	1-1/4
-	1-1/2
-	2"
-	2-1/2
-	3"





FORGED STEEL PIPE FITTINGS

F/S UNIONS			F/S PIPE INSERTS		
					
STOCK NO. 3000#	STOCK NO. 3000# S.W.	SIZE	STOCK NO. 3000# SOCKET WELD	SIZE	
-	-	1/4	PF9143	3/4	x 3/8
-	-	3/8	PF9144	3/4	x 1/2
PF9403	-	1/2	PF9147	1"	x 1/2
PF9404	-	3/4	PF9148	1"	x 3/4
PF9405	PF9415	1"	PF9151	1-1/4	x 3/4
PF9406	PF9416	1-1/4	PF9152	1-1/4	x 1"
PF9407	PF9417	1-1/2	PF9154	1-1/2	x 1/2
PF9408	PF9418	2"	PF9155	1-1/2	x 3/4
PF9409	PF9419	2-1/2	PF9156	1-1/2	x 1"
-	-	3"	PF9157	1-1/2	x 1-1/4
			PF9161	2"	x 1"
			PF9162	2"	x 1-1/4
			PF9168	2-1/2	x 1-1/4
			PF9169	2-1/2	x 1-1/2
			PF9170	2-1/2	x 2"

ADDITIONAL SIZES OF FORGED STEEL PIPE FITTINGS AVAILABLE UPON REQUEST. GIVE US A CALL FOR ALL YOUR NEEDS.

150# STAINLESS STEEL PIPE FITTINGS

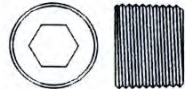
S/S NIPPLES		STAINLESS STEEL TYPE 304		S/S PLUGS	
					
STOCK NO.	SIZE	STOCK NO.	SIZE	STOCK NO.	SIZE
SPF400	1/8 x CLOSE	SPF480	3/4 x CLOSE	SPF01	1/8
SPF401	1/8 x 1-1/2	-	3/4 x 1-1/2	SPF02	1/4
SPF402	1/8 x 2"	SPF482	3/4 x 2"	SPF03	3/8
SPF403	1/8 x 2-1/2	SPF483	3/4 x 2-1/2	SPF04	1/2
SPF404	1/8 x 3"	SPF484	3/4 x 3"	SPF05	3/4
SPF405	1/8 x 3-1/2	SPF485	3/4 x 3-1/2	SPF06	1"
SPF406	1/8 x 4"	SPF486	3/4 x 4"	SPF07	1-1/4
SPF407	1/8 x 4-1/2	SPF488	3/4 x 5"	SPF08	1-1/2
SPF408	1/8 x 5"	SPF490	3/4 x 6"	SPF09	2"
SPF410	1/8 x 6"	SPF500	1" x CLOSE		
SPF420	1/4 x CLOSE	SPF501	1" x 2"	<b>S/S COUNTERSUNK PLUGS</b>	
SPF421	1/4 x 1-1/2	SPF502	1" x 2-1/2		
SPF422	1/4 x 2"	SPF503	1" x 3"	STOCK NO.	SIZE
SPF423	1/4 x 2-1/2	SPF504	1" x 3-1/2	SPF800	1/8
SPF424	1/4 x 3"	SPF505	1" x 4"	SPF801	1/4
SPF425	1/4 x 3-1/2	-	1" x 4-1/2	SPF802	3/8
SPF426	1/4 x 4"	SPF507	1" x 5"	SPF803	1/2
SPF440	3/8 x CLOSE	SPF509	1" x 6"	SPF804	3/4
SPF441	3/8 x 1-1/2	SPF513	1" x 8"	SPF805	1"
SPF442	3/8 x 2"	SPF520	1-1/4 x CLOSE	-	1-1/4
SPF443	3/8 x 2-1/2	SPF521	1-1/4 x 2"	-	1-1/2
SPF444	3/8 x 3"	SPF523	1-1/4 x 3"	-	2"
SPF445	3/8 x 3-1/2	SPF525	1-1/4 x 4"		
SPF446	3/8 x 4"	SPF540	1-1/2 x CLOSE		
SPF447	3/8 x 4-1/2	SPF541	1-1/2 x 2"		
SPF448	3/8 x 5"	SPF542	1-1/2 x 2-1/2		
SPF449	3/8 x 5-1/2	SPF543	1-1/2 x 3"		
SPF450	3/8 x 6"	SPF544	1-1/2 x 3-1/2		
SPF460	1/2 x CLOSE	SPF545	1-1/2 x 4"		
SPF461	1/2 x 1-1/2	-	1-1/2 x 5"		
SPF462	1/2 x 2"	-	1-1/2 x 6"		
SPF463	1/2 x 2-1/2	SPF560	2" x CLOSE		
SPF464	1/2 x 3"	SPF562	2" x 3"		
SPF465	1/2 x 3-1/2	SPF564	2" x 4"		
SPF466	1/2 x 4"	SPF566	2" x 5"		
SPF468	1/2 x 5"	SPF568	2" x 6"		
SPF470	1/2 x 6"	SPF580	2-1/2 x CLOSE		

(CONTINUED)

**150# STAINLESS STEEL PIPE FITTINGS**

**S/S UNIONS**

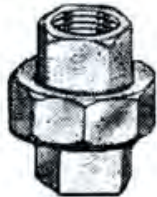

STOCK NO.	SIZE
SPF721	1/4
SPF722	3/8
SPF723	1/2
SPF724	3/4
SPF725	1"
SPF726	1-1/4
SPF727	1-1/2
SPF728	2"

**S/S COUPLINGS**

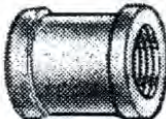

STOCK NO.	SIZE
SPF10	1/8
SPF11	1/4
SPF12	3/8
SPF13	1/2
SPF14	3/4
SPF15	1"
SPF16	1-1/4
SPF17	1-1/2
SPF18	2"

**S/S 90 DEGREE STREET ELBOWS**



STOCK NO.	SIZE
SPF692	1/8
SPF693	1/4
SPF694	3/8
SPF695	1/2
SPF696	3/4
SPF697	1"
SPF698	1-1/4
SPF699	1-1/2
SPF700	2"

ADDITIONAL SIZES AVAILABLE UPON REQUEST

**STAINLESS STEEL TYPE 304**

**S/S HEX BUSHINGS**



STOCK NO.	SIZE
SPF600	1/4 x 1/8
SPF602	3/8 x 1/4
SPF604	1/2 x 1/4
SPF605	1/2 x 3/8
SPF606	3/4 x 1/8
-	3/4 x 1/4
SPF608	3/4 x 3/8
SPF609	3/4 x 1/2
SPF613	1" x 1/2
SPF614	1" x 3/4
-	1-1/4 x 1/2
SPF619	1-1/4 x 3/4
SPF620	1-1/4 x 1"
-	1-1/2 x 1/2
SPF625	1-1/2 x 3/4
SPF626	1-1/2 x 1"
SPF627	1-1/2 x 1-1/4
SPF630	2" x 1"
SPF631	2" x 1-1/4
SPF632	2" x 1-1/2

**S/S 90 DEGREE ELBOWS**

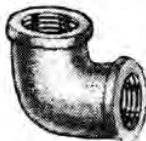

STOCK NO.	SIZE
SPF19	1/8
SPF20	1/4
SPF21	3/8
SPF22	1/2
SPF23	3/4
SPF24	1"
SPF25	1-1/4
SPF26	1-1/2
SPF27	2"

ADDITIONAL SIZES AVAILABLE UPON REQUEST

**S/S REDUCING COUPLINGS**



STOCK NO.	SIZE
-	1/4 x 1/8
-	3/8 x 1/8
-	3/8 x 1/4
-	1/2 x 1/8
-	1/2 x 1/4
-	1/2 x 3/8
-	3/4 x 1/4
-	3/4 x 3/8
-	3/4 x 1/2
-	1" x 1/4
-	1" x 3/8
-	1" x 1/2
-	1" x 3/4

**S/S TEES**



STOCK NO.	SIZE
SPF28	1/8
SPF29	1/4
SPF30	3/8
SPF31	1/2
SPF32	3/4
SPF33	1"
SPF34	1-1/4
SPF35	1-1/2
SPF36	2"

ADDITIONAL SIZES AVAILABLE UPON REQUEST

YOUR SOURCE FOR INDUSTRIAL SUPPLIES



**PIPE ACCESSORIES**

**POWER STRUT**

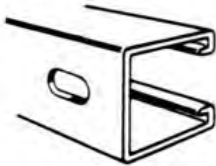

A VERSATILE METAL FRAMING PRODUCT THAT CAN BE USED IN A VARIETY OF APPLICATIONS. WIDELY USED BY ELECTRICAL CONTRACTORS, HVAC, PLUMBING AND FIRE PROTECTION SYSTEMS, AND WITH OEM COMPONENTS AND MAINTENANCE. 12 GA. CHANNEL, WITH 1" x 9/16 ELONGATED HOLES. 10 FT. SECTIONS. GREEN FINISH.

STOCK NO.	SIZE
PHD752	1" X 1-5/8
PHD753	1-5/8 X 1-5/8

**STRUT CLAMPS**

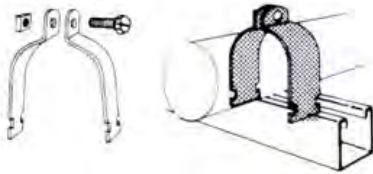

EACH CLAMP COMES WITH BOLT AND NUT.

STOCK NO.	SIZE
PHD74012	1/2
PHD74034	3/4
PHD7401	1"
PHD740114	1-1/4
PHD740112	1-1/2
PHD7402	2"

**SPRING STRUT NUTS**



STOCK NO.	SIZE
PHD73614	1/4
PHD73638	3/8
PHD73612	1/2

*ADDITIONAL SIZES AVAILABLE UPON REQUEST*

**THIS SPACE RESERVED FOR  
FUTURE PIPE-RELATED  
PRODUCTS**

**MALLEABLE BEAM CLAMPS**



MALLEABLE IRON. EACH COMES WITH 3/8-16 HARDENED SQUARE HEAD CUP POINT SET SCREW. PLAIN FINISH.

STOCK NO.	ROD SIZE
PHD350138	3/8-16
PHD350112	1/2-13

**C-CLAMP STYLE**



STOCK NO.	ROD SIZE
PHD270138	3/8-16
PHD270112	1/2-13

**SWIVEL PIPE HANGERS**



STOCK NO.	SIZE	ROD SIZE
GRN6912	1/2	3/8
GRN6934	3/4	3/8
GRN691	1"	3/8
GR691114	1-1/4	3/8
GRN69112	1-1/2	3/8
GRN692	2"	3/8

**ONE-HOLE CLAMPS**



STOCK NO.	SIZE
PHD83512	1/2
PHD83534	3/4
PHD8351	1"

*ADDITIONAL SIZES AVAILABLE UPON REQUEST*

**PIPE/CONDUIT STRAPS**

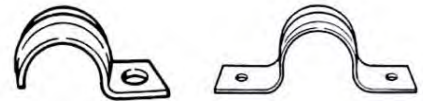

**ONE-HOLE CLAMPS**

STOCK NO.	IPT SIZE	CONDUIT/EMT SIZE
WW001	3/8	1/2
WW002	1/2	3/4
WW003	3/4	1"

**TWO-HOLE CLAMPS**

STOCK NO.	IPT SIZE
WW011	1/4
WW012	3/8
WW013	1/2
WW014	3/4
WW015	1"
WW016	1-1/4
WW017	1-1/2
WW018	2"

*ADDITIONAL SIZES AVAILABLE UPON REQUEST*

**HOSE FAUCETS**



1/2" NPT. MALE PIPE THREAD x HOSE. CAN BE SOLDERED ON PIPE THREAD END.

STOCK NO. V50

**THIS SPACE RESERVED FOR  
FUTURE PIPE-RELATED  
PRODUCTS**

### BRONZE / STEEL VALVE

#### BRONZE BALL VALVES

TWO PIECE THREADED BRONZE



GENERAL OR COMMERCIAL APPLICATION

STOCK NO.	SIZE	PORT	LBS.	
			SWP	WOG
V01	1/4	FULL	150	600
V02	3/8	FULL	150	600
V03	1/2	FULL	150	600
V04	3/4	FULL	150	600
V05	1"	FULL	150	600
V06	1-1/4	FULL	150	600
V07	1-1/2	FULL	150	600
V08	2"	FULL	150	600
MID940179	2-1/2	FULL	125	400
MID940180	3"	FULL	125	400
MID940181	4"	FULL	125	400

TWO PIECE SOLDER JOINT ENDS



GENERAL OR COMMERCIAL APPLICATIONS

STOCK NO.	SIZE	PORT	LBS.	
			SWP	WOG
V12	3/8	FULL	150	600
V13	1/2	FULL	150	600
V14	3/4	FULL	150	600
V15	1"	FULL	125	600
V16	1-1/4	FULL	125	600
-	1-1/2	FULL	125	600
-	2"	FULL	125	600

#### MINI BALL VALVE

FEMALE x FEMALE



STOCK NO.	MID46922I	(1/4 NPT)
STOCK NO.	MID46924I	(1/2 NPT)

WHEN A MAN POINTS A FINGER AT SOMEONE ELSE, HE SHOULD REMEMBER THAT THREE OF HIS FINGERS ARE POINTING AT HIMSELF. --ANONYMOUS

#### STEEL BALL VALVE

HIGH PRESSURE CARBON STEEL



STOCK NO. SIZE PRESSURE

MID949123	1/2	2000#
MID949124	3/4	2000#
MID949125	1"	2000#
MID949126	1-1/4	1500#
MID949127	1-1/2	1500#
MID949128	2"	1500#

#### STAINLESS STEEL BALL VALVE

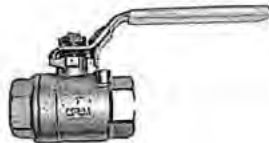

2 PIECES. CONSTRUCTED OF 316 STAINLESS STEEL. THESE ARE DESIGNED FOR INDUSTRIAL USE ON A WIDE RANGE OF FLUID HANDLING APPLICATIONS. THE FULL PORT ALLOWS FOR A MAXIMUM OF FLOW AND A MINIMUM OF PRESSURE DROP.

STOCK NO. SIZE PORT LBS. SWP WOG

MID949161	1/4	FULL	150	1000
MID949162	3/8	FULL	150	1000
MID949163	1/2	FULL	150	1000
MID949164	3/4	FULL	150	1000
MID949165	1"	FULL	150	1000
949166	1-1/4	FULL	150	1000
949167	1-1/2	FULL	150	1000
MID949168	2"	FULL	150	1000

#### BRONZE GATE VALVE



THREADED ENDS

STOCK NO. SIZE LBS SWP WOG

V20	1/4	125	200
V21	3/8	125	200
V22	1/2	125	200
V23	3/4	125	200
V24	1"	125	200
V25	1-1/4	125	200
V251*	1-1/4	125	200
V26	1-1/2	125	200
V27	2"	125	200

\*NON-RISING STEM

#### BRONZE GLOBE VALVE

THREADED ENDS



STOCK NO. SIZE LBS. SWP WOG

V278	3/8	125	200
V30	3/4	125	200
V31	1"	125	200
V32	1-1/4	125	200
V33	1-1/2	125	200
V34	2"	125	200
V36 (SOLDER END)	1/2	125	200

#### BRONZE Y-PATTERN CHECK VALVES

THREADED / HORIZONTAL SWING



STOCK NO. SIZE LBS. SWP WOG

V40	1/2	125	200
V41	3/4	125	200
V42	1"	125	200
V421	1-1/4	125	200
V422	1-1/2	125	200
V423	2"	125	200

#### BRONZE GAS BALL VALVE

AGA & CGA CERTIFIED DESIGNS



STOCK NO.	MID943212	(1/2 NPT)
STOCK NO.	MID943213	(3/4 NPT)

#### STAINLESS STEEL GAS CONNECTOR



STOCK NO.	SIZE
MD3314006	24"
MD3314007	36"



CHANNELLOCK PLIERS FEATURE RIGHT ANGLE TEETH THAT GRIP IN ALL DIRECTIONS FOR MAXIMUM BITE AND MINIMUM WEAR. UNDERCUT TONGUE AND GROOVE DESIGN ASSURES STRONGEST, CAN'T-SLIP ACTION. REINFORCING EDGE MINIMIZES STRESS BREAKAGE. THE CHANNELLOCK PATENTED PERMA-LOCK FASTENER IS FAR STRONGER, SAFER, AND SMOOTHER WORKING THAN THE OLD-TIME NUT AND BOLT. EACH TOOL HAS DISTINCTIVE BLUE-DIPPED PLASTIC COMFORT GRIPS.



WORK HARD. SWEAT BLUE.

**MIDGET PLIER**



A SLIP JOINT MIDGET PLIER IDEAL FOR USE IN IGNITION AND OTHER SMALL WORK. 4-1/2". 3 ADJUSTMENTS. 1/2" CAPACITY.

STOCK NO. CHN424

**POCKET SIZE PLIER**



A SLIP JOINT "JUNIOR SIZE" VERSION OF OUR FAST-SELLING NO. 420 MULTI-PURPOSE PLIER. HANDY FIT-IN-POCKET CONVENIENCE. 6-1/2". 5 ADJUSTMENTS. 7/8" CAPACITY.

STOCK NO. CHN426

**NUT BUSTER® SELF-GRIPPER**



A SLIP JOINT PLIER THAT GRIPS LIKE A PIPE WRENCH BUT IS EASIER TO HANDLE. 9-1/2". 4 ADJUSTMENTS. 1-1/8" CAPACITY.

STOCK NO. CHN410

**MULTI-PURPOSE**



A FAVORITE OF MECHANICS EVERYWHERE. TERRIFIC GRIPPING POWER. REINFORCING RIB GIVES ADDED STRENGTH. SLIP JOINT. 9-1/2". 5 ADJUSTMENTS. 1-1/2" CAPACITY.

STOCK NO. CHN420

**V-JAW**



CURVED JAW MULTI-PURPOSE PLIER FOR GREATER-THAN-EVER GRIPPING POWER ON CURVED OBJECTS. SLIP JOINT.

STOCK NO. CHN422 (9-1/2". 5 ADJ. 1-1/2" CAP.)  
STOCK NO. CHN442 (12". 7 ADJ. 2-1/4" CAP.)

**SMOOTH JAW**



SPECIALLY DESIGNED FOR USE ON PLATED FITTINGS. IDEAL FOR PLUMBERS AND HOME UTILITY SERVICEMEN. SLIP JOINT. 10". 7 ADJUSTMENTS. 2" CAPACITY.

STOCK NO. CHN415



FULL 2" PARALLEL JAW OPENING FOR BIGGER JOBS. UNDERCUT CHANNELS; REINFORCING RIB. SLIP JOINT. 10". 7 ADJUSTMENTS. 2" CAPACITY.

STOCK NO. CHN430



FOR A BIG GRIP ON BIG JOBS IN HARD-TO-REACH SPOTS. JAWS ONLY 5/16" THIN. SLIP JOINT. 12". 7 ADJUSTMENTS. 2-1/4" CAPACITY.

STOCK NO. CHN440

**BIG 16 INCH**



A GIANT-SIZE PLIER WITH ALL THE PATENTED, EXCLUSIVE FEATURES AVAILABLE ONLY IN CHANNELLOCK TONGUE-AND-GROOVE PLIERS. SLIP JOINT. 16". 8 ADJUSTMENTS. 4-1/4" CAPACITY.

STOCK NO. CHN460

**BIGAZZ**



BIG AS THE JOB. BIG AS YOU NEED. PERMALOCK FASTENER ELIMINATES NUT AND BOLT FAILURE. TONGUE-AND-GROOVE. SLIP JOINT. 20-1/4". 12 ADJUSTMENTS. 5-1/2" CAPACITY.

STOCK NO. CHN480

**AIR BRAKE TOOL**



FOR OVER THE ROAD TRUCKS WITH S-CAM BRAKE SYSTEMS. PROVIDES A QUICK AND EASY CHECK OF BRAKE CLEARANCE SYSTEMS WITH AUTO OR MANUAL SLACK ADJUSTERS. 12" 7 ADJUSTMENTS. 2-1/4" CAPACITY.

STOCK NO. CHN444



**LONG NOSE PLIERS**



CROSS HATCHING ON JAWS ELIMINATES SIDE WOBBLE AND PROVIDES A FIRM GRIP ON FINE WORK IN TIGHT PLACES. ALSO HAS A PERFECTLY MATED CUTTER TO HOLD ITS EDGE.

STOCK NO. CHN317 (7-1/2" NEEDLE NOSE)  
STOCK NO. CHN318 (8" HEAVY-DUTY NEEDLE NOSE)

BOTH WITH SIDE CUTTER



STOCK NO. CHN3017 (7-1/2" NEEDLE NOSE) WITHOUT SIDE CUTTER



STOCK NO. CHN326 (6" NEEDLE NOSE) WITH SIDE CUTTER



STOCK NO. CHN3037 (7-1/2" NARROW NEEDLE NOSE) WITHOUT SIDE CUTTER



STOCK NO. CHN386 (6" CURVED NOSE) SERRATED JAWS. WITHOUT SIDE CUTTER.

**LINEMEN'S/ELECTRICIAN'S PLIERS**



HEAVY-DUTY, PRECISION MADE OF HIGHEST GRADE DROP FORGED STEEL. PERFECTLY MATED CUTTERS ARE HAND HONED, PROPERLY HARDENED TO HOLD THEIR EDGE.

STOCK NO. CHN348 (8-1/2". ROUNDED NOSE)  
STOCK NO. CHN349 (9". HIGH LEVERAGE)

**LOCKNUT PLIER**



DESIGNED FOR QUICK AND EASY ADJUSTMENT OF ELECTRICAL LOCKNUTS. FITS: 1/2", 3/4", 1", 1-1/4" AND 1-1/2" LOCKNUTS. THIN PROFILE - FOR USE IN TIGHT/WIRE CONFINED ELECTRICAL BOXES. SPRING LOADED HANDLES. 8-1/2".

STOCK NO. CHN960

**ADDITIONAL ITEMS  
AVAILABLE UPON REQUEST**



**SLIP JOINT PLIERS**



POLISHED HIGH CARBON DROP FORGED STEEL. PERMALOCK FASTENER ELIMINATES NUT AND BOLT FAILURE. 6" THIN NOSE CUTTING SHEAR.

STOCK NO. CHN516  
STOCK NO. VAD5118 (KLEIN TOOL BRAND)



6" UTILITY WIRE CUTTING SHEAR  
STOCK NO. CHN526



7" W/ FINE SIDE CUTTER  
STOCK NO. CHN537



6" HEAVY-DUTY WIRE CUTTING SHEAR  
STOCK NO. CHN546

8" HEAVY-DUTY WIRE CUTTING SHEAR  
STOCK NO. CHN548

10" HEAVY-DUTY WIRE CUTTING SHEAR  
STOCK NO. CHN5410

**LONG REACH PLIERS**

SPECIALLY DESIGNED FOR ELECTRONICS AND ELECTRICAL WORK. FINE POLISHED DROP FORGED STEEL. PRECISION MATCHED JAWS. HAND HONED; SPECIALLY HARDENED CUTTING EDGES. LONG REACH FOR CONFINED AREAS.



8" FLAT NOSE  
STOCK NO. CHN718



7-1/2" DIAGONAL CUTTER  
STOCK NO. CHN728



8" NEEDLE NOSE  
STOCK NO. CHN738



8" END CUTTER  
STOCK NO. CHN748

**DIAGONAL CUTTERS**

HAND HONED. PERFECTLY MATED CUTTERS SCIENTIFICALLY HEAT TREATED TO HOLD THEIR EDGE. PRECISION MADE OF FINE POLISHED FORGED STEEL.



7" LAP JOINT  
STOCK NO. CHN337

8" LAP JOINT  
STOCK NO. CHN338



7" WIRING PLIER (CUTS AND STRIPS INSULATION)  
STOCK NO. CHN337W



5" BOX JOINT  
STOCK NO. CHN435

7" BOX JOINT  
STOCK NO. CHN437



7" CURVED DIAGONAL BOX JOINT  
STOCK NO. CHN447

**SPECIAL PURPOSE PLIERS**



DROP FORGED OF HIGH GRADE STEEL. FINE POLISHED FINISH.  
7" END CUTTER  
STOCK NO. CHN357



CONVERSION SNAP RING PLIER. FOR USE WITH EITHER EXTERNAL OR INTERNAL RINGS.  
STOCK NO. CHN907



WIRING TOOL. CRIMPS BOTH INSULATED AND NON-INSULATED WIRE.  
STOCK NO. CHN908



CRIMPING TOOL. DESIGNED FOR CRIMPING AND CUTTING BOTH INSULATED AND NON-INSULATED SOLDERLESS CONNECTORS AND TERMINALS.  
STOCK NO. CHN909



9-1/2" CABLE CUTTER DESIGNED FOR SOFT MATERIALS SUCH AS COPPER (NO STEEL).  
STOCK NO. CHN911



**CABLE CUTTER SNIPS**



CUTS COPPER AND WIRE CABLE UP TO 3/8" DIAMETER. STAINLESS STEEL BLADES AND EASY-GRIP HANDLE. FLIP LOCK. THIS ITEM IS BESSEY BRAND.

STOCK NO. JM49

**POCKET WIRE ROPE AND CABLE CUTTERS**



DROP FORGED CONSTRUCTION FOR LONG LASTING QUALITY. PRECISION GROUND SHEAR CUT BLADES WILL EASILY CUT THROUGH FINE STRANDED WIRE.

CAPACITIES: COPPER/ALUMINUM - 1/4"  
WIRE ROPE - 3/16"

STOCK NO. HKP0690TN  
SIZE 7-1/2" LONG

**ADDITIONAL ITEMS AVAILABLE UPON REQUEST**

**GIVE US  
A  
CALL**



**FOR  
ALL YOUR  
NEEDS**

# WISE-GRIP®

## LOCKING HAND SPECIALTY TOOLS

# WISE-GRIP®

### FULL ONE-YEAR WARRANTY

ALL VISE-GRIP TOOLS, HAVING PASSED A RIGID FACTORY INSPECTION, ARE WARRANTED AGAINST DEFECTS IN MATERIALS AND WORKMANSHIP FOR ONE YEAR FROM DATE OF ORIGINAL PURCHASE. ANY VISE-GRIP TOOL THAT IS ABUSED, OR USED FOR PURPOSES OTHER THAN THOSE FOR WHICH THE TOOL WAS DESIGNED, IS EXCLUDED FROM WARRANTY. *THIS WARRANTY DOES NOT EXTEND TO CONSEQUENTIAL DAMAGES EXCEPT WHERE REQUIRED BY LAW.* IF A VISE-GRIP TOOL APPEARS DEFECTIVE, IT MAY BE RETURNED TO THE FACTORY. IF A FACTORY INSPECTION DETERMINES THAT THE TOOL IS WITHIN THIS WARRANTY, THE TOOL WILL BE REPAIRED OR REPLACED WITHOUT CHARGE. THIS WARRANTY GIVES YOU SPECIFIC RIGHTS WHICH MAY VARY FROM STATE TO STATE. THE FACTORY RECOMMENDS AN OCCASIONAL DROP OF OIL ON ALL POINTS OF WEAR TO INSURE BETTER OPERATION AND PROLONG THE LIFE OF THE TOOL.

### CURVED JAW LOCKING PLIERS

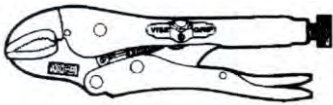

BOTH SIZES HAVE CURVED JAWS FOR BETTER CONTACT ON BOLT HEADS, NUTS AND ROUND WORK. SIMPLY TURN THE MICRO-ADJUSTING SCREW TO SET JAWS FOR PROPER SIZE AND PRESSURE, OR FOR PLIERS ACTION.

STOCK NO.	SIZE	JAW THICKNESS	JAW ADJUSTMENT
VG7CR	7"	5/16"	1-5/8"
VG10CR	10"	3/8"	1-7/8"

### CURVED JAW LOCKING PLIERS WITH WIRE CUTTER



ALL FOUR SIZES HAVE CURVED JAWS, KNURLED TIPS AND WIRE CUTTERS. PROPERLY ADJUSTED AND LOCKED TO THE WORK, VISE-GRIP TOOLS WON'T SLIP. INSTANT LOCK-ON AND RELEASE. THEY ALSO ADJUST TO PLIERS ACTION.

STOCK NO.	SIZE	JAW THICKNESS	JAW ADJUSTMENT
VG4WR	4"	1/4"	1"
VG5WR	5"	1/4"	1-1/8"
VG7WR	7"	5/16"	1-1/2"
VG10WR	10"	3/8"	1-7/8"

### LOCKING CHAIN CLAMP



HOLDS AND LOCKS AROUND ANY SIZE OR SHAPE. ADJUSTS TO RATCHET ACTION IN EITHER DIRECTION. WON'T SLIP OR CRUSH THIN-WALLED PIPE. 18" CHAIN LENGTH.

STOCK NO. VG20R (CLAMP)  
STOCK NO. VG20REP (REPLACEMENT CHAIN)

### STRAIGHT JAW LOCKING PLIERS



BOTH SIZES ARE MODERN VERSIONS OF THE ORIGINAL VISE-GRIP LOCKING PLIERS/WRENCH. BUILT RUGGED. VISE-GRIP TOOLS LOCK INSTANTLY, RELEASE QUICKLY AND ADJUST TO PLIERS ACTION.

STOCK NO.	SIZE	JAW THICKNESS	JAW ADJUSTMENT
VG7R	7"	7/16"	1-1/2"
VG10R	10"	5/8"	1-3/4"

### LONG NOSE LOCKING PLIERS WITH WIRE CUTTER

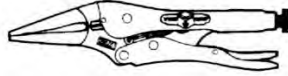

LONG NOSE JAWS REACH INTO TIGHT SPOTS WHERE OTHER TOOLS CAN'T. BUILT-IN WIRE CUTTER. ADJUSTS EASILY FOR PROPER LOCKING PRESSURE.

STOCK NO.	SIZE	JAW THICKNESS	JAW ADJUSTMENT
VG4LN	4"	1/8" AT TIP 1/4" AT BASE	1-3/4" AT TIP 3/4" AT BASE
VG6LN	6"	1/8" AT TIP 5/16" AT BASE	2-1/4" AT TIP 1" AT BASE
VG9LN	9"	3/8" AT TIP 13/32" AT BASE	3" AT TIP 1-3/4" BASE

### LARGE JAW LOCKING PLIERS

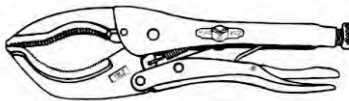

WORKS AS A PIPE WRENCH, ESPECIALLY IN TIGHT PLACES. GREAT FOR AUTOMOTIVE WORK, SUCH AS REMOVING TAIL PIPES. IDEAL FOR CLAMPING ODD-SHAPED PIECES FOR WELDING. BUILT OF HIGH-GRADE STEEL CONSTRUCTION AND LOCKS ONTO WORK WITHOUT SLIPPING. EASY LOCKING AND QUICK RELEASE ACTION.

STOCK NO.	SIZE	JAW OPENING
VG12LC	12"	3-1/8"

### LOCKING WELDING CLAMP



HOLDS PARTS IN PROPER ALIGNMENT- EVEN WHEN MATERIAL IS NOT IDENTICAL IN THICKNESS. DEEP-THROATED U-SHAPED JAWS FOR PERFECT VISIBILITY AND WORK SPACE.

STOCK NO.	SIZE	JAW ADJUSTMENT	JAW DEPTH
VG9R	9"	2-3/4"	2-1/2"

### LOCKING WRENCH WITH WIRE CUTTER

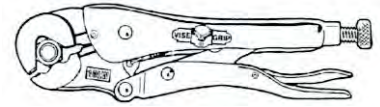

LOCKS ONTO THREE SIDES OF A HEX FASTENER. EACH WRENCH ADJUSTS TO OVER 16 DIFFERENT STANDARD AND METRIC WRENCH SIZES. JAW TIPS ARE KNURLED FOR BETTER GRIPPING.

STOCK NO.	WRENCH SIZE RANGE
VG4LW	1/4" - 9/16" 7MM - 14MM
VG7LW	7/16" - 3/4" 11MM - 19MM
VG10LW	5/8" - 1-1/8" 16MM - 28MM

### LOCKING C-CLAMPS

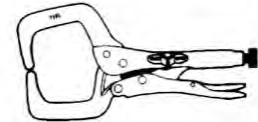

STOCK NO.	SIZE	JAW ADJUSTMENT
VG6R	6"	0 - 2"
VG11R	11"	0 - 3-3/8"
VG18R	18"	0 - 8"



WITH SWIVEL PADS (SELF-LEVELING)

JAW NO.	STOCK	SIZE	ADJUSTMENT
VG6SP	6"	0 - 2"	
VG11SP	11"	0 - 3-3/8"	
VG18SP	18"	0 - 8"	

### LOCKING SHEET METAL TOOL



LOCKS TO WORK WITH POWERFUL GRIP FOR SMOOTH AND ACCURATE BENDING AND SEAMING. MICRO-ADJUSTING SCREW AND EASY RELEASE TRIGGER.

STOCK NO.	SIZE	JAW WIDTH	THROAT DEPTH
VG8R	8"	3-1/8"	1-3/4"

**A LARGE VARIETY OF TOOLS  
FOR A LARGE VARIETY OF  
APPLICATIONS**

**METAL CUTTING SNIPS AND BANDING CUTTERS**

**METAL CUTTING SNIPS**

IDEAL FOR CUTTING SHEET METAL, WIRE, LEATHER, SCREENING, RUBBER, GASKET MATERIALS, PLASTICS, LINOLEUM, ROOFING AND OTHER SUCH MATERIALS. INDIVIDUALLY FITTED HOLLOW GROUND BLADES ASSURE EASY, POSITIVE CUTTING. OUTER BLADES SMOOTH POLISHED TO FACILITATE MOVEMENT THROUGH MATERIAL WITHOUT CATCHING OR TEARING. SPECIAL LOCK NUT KEEPS JAWS ALIGNED. HIGHEST QUALITY DROP-FORGED STEEL, PROPERLY HEAT TREATED FOR TOUGHNESS, STRENGTH AND DURABILITY.



**STRAIGHT SNIPS**

7" LENGTH, 1-3/4" CUT STOCK NO. VG007  
10" LENGTH, 2-1/2" CUT STOCK NO. VG010

12-1/2" LENGTH, 3" CUT STOCK NO. VG012



**DUCKBILL OR CIRCULAR PATTERN SNIPS**

7" LENGTH, 1-3/4" CUT STOCK NO. VG207

12-1/2" LENGTH, 3" CUT STOCK NO. VG212

**STEEL BANDING CUTTERS**



FORGED STEEL JAWS. CUTS BANDING 1" WIDE x 1/32" to 3/64" THICK. P.V.C. COVERED HANDLES. 10-1/2" LENGTH.

STOCK NO. JM122S



CLEAN, EASY CUTTING BLADES. LOWER JAW FITS UNDER TIGHT STRAPPING UP TO 3/4". 9" LENGTH.

STOCK NO. HKP0990T

(CONTINUED NEXT COLUMN)

**STEEL BANDING CUTTERS (CONTINUED)**



SHEER-CUT BLADES. ONE HANDED OPERATION GIVES EXTRA LEVERAGE FOR CONTINUOUS CUTS OF 1-1/4" WIDE STEEL STRAP.

STOCK NO. HKP1290G



SHEER-CUT BLADES. CUTS HEAVY STEEL STRAPPING UP TO 2". 24" LENGTH.

STOCK NO. HKP2690GP

**AVIATION SNIPS**

EXCELLENT FOR CUTTING 18 GAUGE OR LIGHTER COLD ROLLED STEEL. COMPOUND ACTION PROVIDES MAXIMUM CUTTING POWER WITH MINIMUM EFFORT. HIGH POLISHED, INDIVIDUALLY FITTED BLADES WITH SERRATIONS TO GRIP METAL ASSURE SMOOTH, POSITIVE, EASY CUTTING. EASY-TO-USE LATCH. BLADES ARE DROP FORGED OF MOLYBDENUM ALLOY TOOL STEEL SCIENTIFICALLY HEAT TREATED FOR EXTRA STRENGTH, TOUGHNESS, DURABILITY.



CUTS STRAIGHT, 10" LENGTH, 1-1/2" CUT STOCK NO. FCP6716S

CUTS RIGHT, 10" LENGTH, 1-3/8" CUT STOCK NO. FCP6716R

CUTS LEFT, 10" LENGTH, 1-3/8" CUT STOCK NO. FCP6716L

CUTS STRAIGHT, 12" LENGTH, 3" CUT STOCK NO. FCP6716A

**ADDITIONAL SNIPS AND CUTTERS AVAILABLE UPON REQUEST**

**LIGHT METAL AND WIRE CUTTING SNIPS**

HANDY, MULTI-PURPOSE SNIPS FOR CUTTING WIRE, SHEET METAL, ROPE, YARN OR EVEN PAPER. SPRING OPENER FOR EASY OPERATION. DROP FORGED, SCIENTIFICALLY HEAT TREATED CARBON STEEL. PRECISION GROUND CUTTING EDGES. LONG NOSE. 6-1/2" LENGTH, 1-1/4" CUT.



STOCK NO. FCP657N

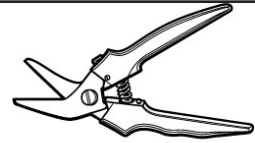

MULTI-PURPOSE SNIPS WITH STAINLESS STEEL CUTTING BLADES AND SERRATED EDGES. SHOCK-PROOF PLASTIC HANDLES. 7-1/2" LENGTH.

STOCK NO. JM48A

**OFFSET SNIPS**



RIGHT AND LEFT CUTTING MODELS. DESIGNED SPECIFICALLY FOR CUTTING SHEET METAL, LINOLEUM, CARPET AND TILE. FORGED STEEL BLADES CUT IN THREE DIRECTIONS. UNIQUE CURVED HANDLE FITS COMFORTABLY AND KEEPS HANDS SAFELY ABOVE WORK.

LEFT CUT STOCK NO. VG20SL

RIGHT CUT STOCK NO. VG20SR

**YOU ONE-STOP SOURCE FOR INDUSTRIAL SUPPLIES**



**RETAINING RING PLIERS**

**SNAP RING PLIERS**



REMOVES AND INSTALLS **INTERNAL** SNAP RINGS. MANUFACTURED FROM HIGH CARBON HEAT-TREATED STEEL. INCLUDES FOUR PAIRS OF INTERCHANGEABLE TIPS. INTERNAL RANGE 3/8" - 1-3/4".

**STOCK NO. CTA8845**

REMOVES AND INSTALLS **EXTERNAL** SNAP RINGS. INCLUDES FOUR PAIRS OF INTERCHANGEABLE POINTS. EXTERNAL RANGE 1/4" - 1-7/16".

**STOCK NO. CTA8846**

**CONVERSION SNAP RING PLIERS**



FOR USE WITH EITHER INTERNAL OR EXTERNAL SNAP RINGS. CONVERTS QUICKLY BY A THUMB-PUSH OF TWO SLIDERS. SERVES INTERNAL RINGS 3/8" - 2" AND EXTERNAL RINGS 1/4" - 2".

**STOCK NO. CHN907**

**LIGHT-DUTY CONVERSION SNAP RING PLIERS**



FOR USE WITH EITHER INTERNAL OR EXTERNAL SNAP RINGS. CONVERTS QUICKLY BY THUMB SCREW. SERVES INTERNAL RINGS 0.375 - 1.00 AND EXTERNAL RINGS 0.250 - 0.875. TIPS ARE NOT INTERCHANGEABLE.

**STOCK NO. VA73245**

**2-PIECE SNAP RING PLIER SET**



HEAVY DUTY SET MADE OF DROP FORGED HEAT TREATED STEEL. CAN BE USED FOR INTERNAL AND EXTERNAL SNAP RINGS. RANGE 1-13/16" - 3-1/2". INCLUDES .012 AND .018 CLIPS WITH STRAIGHT, 15°, 45° AND 90° TIPS, IN BOTH INTERNAL AND EXTERNAL STYLES

**STOCK NO. GRIP57148**

**ADDITIONAL ITEMS AVAILABLE  
UPON REQUEST**

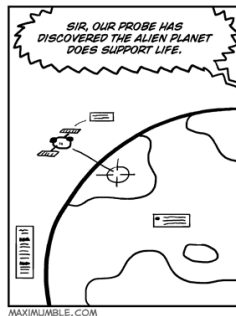

MAXIMJUMBLE.COM

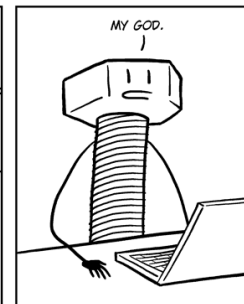
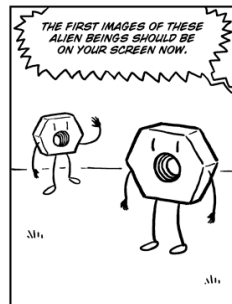

©2011 CHRIS HALLBECK



**LET OUR INVENTORY  
SERVE AS  
YOUR INVENTORY**

**KLEIN TOOLS**  
for Professionals... since 1857™

**SCREWDRIVERS FOR INDUSTRY**

**Pratt-Read**

**ROUND BLADE SCREWDRIVERS FOR SLOTTED SCREWS**

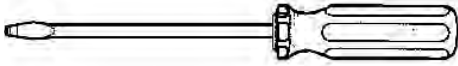

BLADES ARE HIGH CARBON STEEL. FULL-TEMPERED FOR STRENGTH WITH PRECISION GROUND TIPS. POLISHED AND PLATED FOR LONG LIFE. HANDLES ARE HIGH IMPACT, SHOCK RESISTANT PLASTIC. FULL FLUTED AND PERFECTLY BALANCED.

**POCKET-CLIP STYLE**

STOCK NO.	TIP WIDTH	BLADE LENGTH	OVERALL LENGTH
VAA1302	1/8	2"	3-7/8
VAA1303	1/8	3"	4-7/8

**REGULAR STYLE**

STOCK NO.	TIP WIDTH	BLADE LENGTH	OVERALL LENGTH
VAA2163	1/8	3"	6"
VAA2164	1/8	4"	7"
VAA2166	1/8	6"	9"
VAA2168	1/8	8"	11"
IR75703	3/16	3"	6-3/4
IR75904	3/16	4"	7-3/4
IR75906	3/16	6"	9-3/4
VAA31610	3/16	10"	13-1/2
IR75701	1/4	1"	3"
IR75704	1/4	4"	8-1/4
IR41143	1/4	4"	8-3/8
IR41144	1/4	6"	10-3/8
IR75712	3/8	12"	17-1/4

**SQUARE BLADE SCREWDRIVERS FOR SLOTTED SCREWS**

STOCK	TIP	BLADE	OVERALL
-------	-----	-------	---------

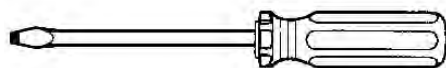

NO.	WIDTH	LENGTH	LENGTH
VAA3168	3/16	8"	11-1/2
IR41145	1/4	8"	12-3/8
IR41146	1/4	10"	14-3/8
IR76506	5/16	8"	13"
IR76508	3/8	8"	13-1/4
MAY36019	1/2	19"	25"

**POCKET-CLIP ROUND SHANK PHILLIPS TIP**



DESIGNED FOR THE SMALLEST SIZE PHILLIPS SCREWS AND WITH CONVENIENT POCKET CLIP. 2-1/2" SHANK. OVERALL LENGTH 5".

STOCK NO. VAP12

**PHILLIPS SCREWDRIVERS**

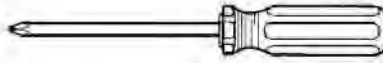

STOCK NO.	POINT NO.	BLADE LENGTH	OVERALL LENGTH
VAP01	0	2-1/2	5-1/4
IR76103	1	3"	6-3/4
IR76102	2	1-1/2	3-1/2
IR76104	2	4"	8-1/4
IR76105	2	6"	10-1/4
VAP212	2	12"	15-5/8
IR76106	3	6"	10-3/4

**OFFSET SCREWDRIVER SET**



OFFSET DRIVERS PROVIDE THE EXACT TOOL NEEDED FOR WORKING IN CONFINED AREAS. SET CONTAINS A P120 (NO. 1 AND NO. 2 PHILLIPS TIP) AND A VO2 (1/4 TO 5/16 SLOTTED).

STOCK NO. VA210122

**MAGNETIC SCREWDRIVER**

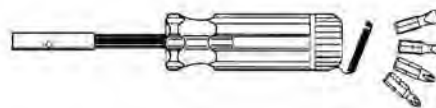

MAGNETIC HOLDING ACTION. POWERFUL MAGNET BUILT INTO SHANK HOLDS INTERCHANGEABLE BITS AND ALSO HOLDS SCREW. HANDLE BUILT FOR FATIGUE-FREE DRIVING. REMOVABLE SMOOTH DOME CAP STORES EXTRA BITS INSIDE HANDLE. BITS INCLUDE 3/16 AND 9/32 SLOTTED, AND NO. 1 & NO. 2 PHILLIPS.

STOCK NO. VA70035

**IF YOU DON'T SEE SOMETHING HERE YOU NEED, GIVE US A CALL.**



**WE WILL DO OUR BEST TO FIND IT FOR YOU.**

**COMBINATION SCREWDRIVERS**

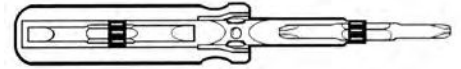

VERSATILE INTERCHANGEABLE BIT DRIVERS WITH BLADES. DIFFERENT TIPS ON REVERSIBLE BLADES. BITS ARE HELD SECURELY. SHOCK RESISTANT HANDLE.

**2 IN 1 SCREWDRIVER**

POCKET SCREWDRIVER WITH A PHILLIPS AND SLOTTED BIT THAT REVERSES IN THE HANDLE. STOCK NO. LFT22210

**4 IN 1 SCREWDRIVER**

NO. 1 AND NO. 2 PHILLIPS, AND 3/16 & 5/16 SLOTTED BITS STOCK NO. EV4IN1

4 IN 1 REPLACEMENT SLOTTED BIT STOCK NO. EVDESL48

4 IN 1 REPLACEMENT PHILLIPS BIT STOCK NO. EVDEPH12

**6 IN 1 SCREWDRIVER**

NO. 1 & NO. 2 PHILLIPS, 3/16 & 5/16 SLOTTED BITS, AND 1/4 & 5/16 HEX SOCKET STOCK NO. EV6IN1

**16 IN 1 SECURITY SCREWDRIVER**

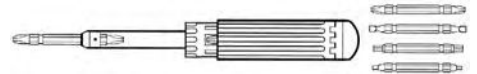

INCLUDES THE FOLLOWING BITS: #2 PHILLIPS, #8 SLOTTED, #4, 6, 8, 10 SPANNER, #1, #2 TAMPERPROOF SQUARE, #10, 15, 20, 25 TAMPERPROOF TORX, AND 1/8, 9/16, 5/32, 3/16 TAMPERPROOF HEX.

STOCK NO. EV16IN1S

**15 IN 1 MEGAPRO SCREWDRIVER**

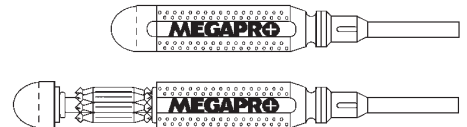

INCLUDES 7 DOUBLE-ENDED BITS (PHILLIPS, SQUARE, TORX AND SLOTTED)

STOCK NO. EV15IN1

WISDOM DOESN'T NECESSARILY COME WITH AGE. SOMETIMES AGE JUST SHOWS UP ALL BY ITSELF.

-- TOM WILSON

**Pratt-Read**

**SCREWDRIVERS/SPECIAL PURPOSE TOOLS**

**Pratt-Read**

**HEAVY DUTY SCREWDRIVER  
5 PC SET**



BIGGER SCREWDRIVERS FOR THOSE BIGGER FASTENERS. DELIVERS EXCELLENT RESULTS. CONTENTS: SLOTTED - 5/16 X 6, 5/16 X 8, 3/8 X 8, 3/8 X 12. PHILLIPS - NO.3 X 6.

STOCK NO. IR81022

**SUPER STUBBY SCREWDRIVER  
4 PC SET**



THIS SET WILL GET AT THOSE FASTENERS IN TIGHT SPACES AND CLOSE QUARTERS WITHOUT COMPROMISING STRENGTH OR CONTROL. CONTENTS: SLOTTED - 3/16 X 1-1/2, 1/4 X 1-1/2, PHILLIPS - NO. 1 AND 2.

STOCK NO. IR82005

**PRECISION SCREWDRIVER 6 PC SET**



THIS SET OF PRECISION SCREWDRIVERS IS PERFECT FOR ASSEMBLY AND REPAIR OF SMALL PARTS AND FASTENERS FOUND IN TODAY'S ELECTRONICS, JEWELRY AND PRECISION COMPONENTS. CONTENTS: SLOTTED: 1/16 X 1-1/2, 5/64 X 2, 3/32 X 2, PHILLIPS - NO. 0000, NO. 000 AND NO. 00.

STOCK NO. IR81001

**EXTRA LONG SCREWDRIVER  
8 PC SET**



THIS SET OF THE MOST FREQUENTLY USED SCREWDRIVERS HAVE EXTRA LONG BLADE EXPOSURES FOR GETTING TO THOSE HARD TO REACH FASTENERS. CONTENTS: SLOTTED - 1/8 X 6, 3/16 X 9, 1/4 X 8, 1/4 X 12, PHILLIPS NO. 0, NO. 1, NO. 2.

STOCK NO. IR82019

**STUBBY SCREWDRIVER 4 PC SET**



THIS SET WILL ALLOW YOU TO GET AT THOSE FASTENERS IN TIGHT SPACES AND CLOSE QUARTERS. CONTENTS: SLOTTED - 3/16 X 1-1/2, 1/4 X 1-1/2, PHILLIPS - NO. 1 AND 2.

STOCK NO. IR81003

**CUSHION GRIP SCREWDRIVER  
8 PC SET**



USE ON MOST JOBS THAT USE THE MOST COMMON FASTENERS FOUND DRUING INSTALLATION, ASSEMBLY AND REPAIR OF TODAY'S ELECTRICAL ELECTRONIC, HARDWARE AND LIGHTING COMPONENTS. CONTENTS: SLOTTED 3/16 X3, 1/4 X 1-1/2, 1/4 X 4, 5/16 X 6. PHILLIPS - NO. 1 X 3, NO. 2 X 1-1/2, NO. 2 X 4, NO. 3 X 6.

STOCK NO. IR83014

**SAE BALL HEX SCREWDRIVER  
7 PC SET**

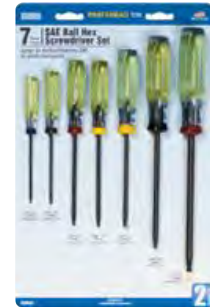

BALL HEX DRIVERS ARE DESIGNED TO ALLOW OFF - ANGLE ROTATION AND PERMITS EASY ACCESS IN HARD TO REACH AREAS TO QUICKLY INSTALL OR REMOVE FASTENERS. CONTENTS: 3/32 X 3, 7/64 X 3, 1/8 X 4, 9/64 X 4, 5/32 X 4, 3/16 X 5 AND 1/4 X 6.

STOCK NO. IR82040

**PRECISION HOOK AND PICK  
4 PC SET**



THIS PRECISION HOOK AND PICK SET IS PERFECT FOR ADJUSTING AND RETRIEVING SMALL PARTS, REMOVING "O" RINGS, FUSES, AND CLIPS. CONTENTS: STRAIGHT PICK, 90° BEND PICK, COMPLEX BEND PICK AND ROUND HOOK.

STOCK NO. IR81061

**TORX SCREWDRIVER 6 PC SET**



THIS SET WILL HANDLE THE MOST COMMON 6 POINT STAR-SHAPED FASTENERS. CONTENTS: T10, T15, T20, T25, T27, T30.

STOCK NO. IR81033

**KLEIN TOOLS**  
for Professionals... since 1857™

**SCREWDRIVERS / SPECIAL PURPOSE TOOLS** *Pratt-Read*

**SCREW HOLDING DRIVERS**



HOLDS, STARTS AND DRIVES WITH POWER AND COMFORT. NOT DESIGNED TO TIGHTEN SCREWS.

STOCK NO.	BLADE SIZE	OVERALL LENGTH
VAK21*	1/8 x 3"	5-1/4
VAK23	1/8 x 3"	5-1/4
VAK34	3/16 x 4"	7-3/4
VAK36	3/16 x 6"	9-3/4
VAK38	3/16 x 8"	11-3/4
VAK44	1/4 x 4"	8-1/4
VAK46	1/4 x 6"	10-1/4
-	1/4 x 8"	12-1/4

\*SPECIALLY GROUND TIP FOR USE ON MINIATURE SCREWS

**JEWELERS' SCREWDRIVERS**



FOR JEWELERS, INSTRUMENT MAKERS, AND SUB-MINIATURE PARTS ASSEMBLERS. SWIVEL HEADS. 1/4" BODY DIAMETER. 3-7/8" LONG OVERALL. BLADE SIZES .100, .080, .070, .055, .040, .025.

STOCK NO. GENSPC600

**FIVE BLADE SCREWDRIVER SET**

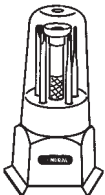

FOR HOME MECHANICS AND HOBBYISTS. A SINGLE SWIVEL-HEAD SCREWDRIVER WITH FIVE INTERCHANGEABLE BLADES INCLUDING .040, .055, .070, .100 AND NO. 0 CROSSPOINT BLADE.

STOCK NO. GENSG05

**CALL FOR COMPLETE**



**SPECIFICATIONS AND PRICES**

**SCREW STARTERS**



THESE HANDY TOOLS PROVIDE POSITIVE HOLDING POWER FOR STARTING SLOT HEAD, PHILLIPS AND REED & PRICE SCREWS IN HARD-TO-REACH PLACES. SPRING-ACTION STARTING MECHANISM GRIPS INSIDE SCREW SLOT AND RELEASES AUTOMATICALLY AS SCREW IS TIGHTENED. FURNISHED WITH NYLON OR ALUMINUM HANDLES WITH OR WITHOUT 1" MAGNETIC TIP.

STOCK NO.	OVERALL LENGTH	HANDLE TYPE
RIM0875	2-5/8	ALUM. W/MAG.
RIM0869	9"	NYLON

**HOLLOW SHAFT NUT DRIVERS**

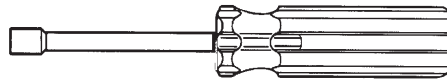

3" SHAFT LENGTH

1" x 3-5/8" HANDLE SIZE, 3/16" HEX SIZE, 6-5/8" OVERALL LENGTH. BLACK HANDLE. STOCK NO. VAS6

1" x 3-5/8" HANDLE SIZE, 1/4" HEX SIZE, 6-5/8" OVERALL LENGTH. RED HANDLE. STOCK NO. VAS8

1" x 3-5/8" HANDLE SIZE, 5/16" HEX SIZE, 6-5/8" OVERALL LENGTH. ORANGE HANDLE. STOCK NO. VAS10

1" x 3-5/8" HANDLE SIZE, 11/32" HEX SIZE, 6-5/8" OVERALL LENGTH. GREEN HANDLE. STOCK NO. VAS11

1" x 3-5/8" HANDLE SIZE, 3/8" HEX SIZE, 6-5/8" OVERALL LENGTH. BLUE HANDLE. STOCK NO. VAS12

1-1/16 x 4" HANDLE SIZE, 7/16" HEX SIZE, 7" OVERALL LENGTH. BROWN HANDLE. STOCK NO. VAS14

1-1/16 x 4" HANDLE SIZE, 1/2" HEX SIZE, 7" OVERALL LENGTH. RED HANDLE. STOCK NO. VAS16

**EXTRA-LARGE HEX SIZE 4" SHAFT LENGTH**

1-1/16 x 4" HANDLE SIZE, 9/16" HEX SIZE, 8-1/2" OVERALL LENGTH. RED HANDLE. STOCK NO. VAS18

ADDITIONAL ITEMS AVAILABLE UPON REQUEST

**3/8" HAND IMPACT DRIVER SET**



WILL LOOSEN SCREWS AND BOLTS EVEN WHEN RUSTED OR WEDGED TIGHT. IDEAL FOR USE ON CAR DOOR STRIKER PLATES. SET INCLUDES: -1 HEX ADAPTER WITH 5/16 BITS -2 SLOTTED BITS (9/32 & 5/16) -2 PHILLIPS BITS (NO. 2 & NO. 3)

STOCK NO. CTA9311

**7-PIECE NUT DRIVER SET**

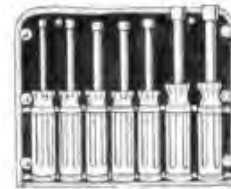

THE FAMOUS K7 KIT CONTAINS 7 HOLLOW-SHAFT NUT DRIVERS IN THE MOST POPULAR HEX SIZES. CONVENIENT VINYL POUCH HANGS UP, ROLLS UP, OR STANDS UP. SET INCLUDES 1 EACH: 3/16, 1/4, 5/16, 11/32, 3/8, 7/16, 1/2 HEX SIZES.

STOCK NO. VAK7

**TORX SOCKET SET**



10 PIECE SET INCLUDES VINYL HOLDER AND THE FOLLOWING 1/4 AND 3/8 DRIVE SOCKETS: T10, T15, T20, T25, T27, T30, T40, T45, T50 AND T55.

STOCK NO. CTA9560

© MARK ANDERSON WWW.ANDERSTOONS.COM

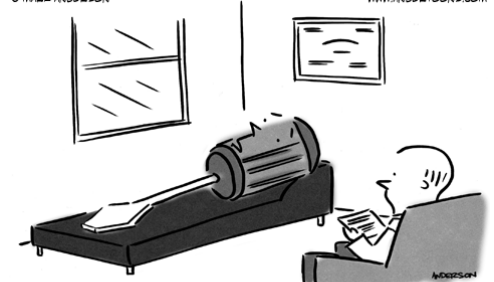

"You know, there's more to me than just lefty loosey, righty tighty."

POWER BITS

PHILLIPS INSERT BITS



STOCK NO.	POINT SIZE	HEX SHANK	OVERALL LENGTH
MAG27019	#0	1/4	1"
MAG27020	#1	1/4	1"
MAG27021	#2	1/4	1"
EV4P2L*	#2	1/4	1"
MAG27022	#3	1/4	1"
MAG27205	#1	5/16	1-1/4
MAG27206	#2	5/16	1-1/4
MAG27207	#3	5/16	1-1/4
MAG27208	#4	5/16	1-1/4

\* - DEPTH SETTER BIT

PHILLIPS POWER BITS - 1/4" SHANK



STOCK NO.	POINT SIZE	BODY DIA.	OVERALL LENGTH
MAG27360	#1	3/16	2"
MAG28310	#1	3/16	3"
MAG28313	#1	3/16	4"
MAG27369	#1	1/4	6"
MAG27361	#2	1/4	2"
MAG28311	#2	1/4	3"
MAG28314	#2	1/4	4"
MAG27370	#2	1/4	6"
MAG27362	#3	1/4	2"
MAG28312	#3	1/4	3"
MAG28315	#3	1/4	4"
MAG27371	#3	1/4	6"

SLOTTED INSERT BITS - 1/4" SHANK



STOCK NO.	BLADE THICKNESS	BLADE WIDTH	OVERALL LENGTH
EV250SS1	.024	.125	1"
MAG39534	.034	.187	1"
MAG39535	.036	.218	1"
MAG39536	.040	.250	1"
MAG39537	.042	.281	1"
MAG39538	.046	.281	1"
MAG39539	.050	.281	1"
MAG27000	.034	.187	1-1/2
MAG27001	.040	.250	1-1/2
MAG27002	.042	.281	1-1/2
MAG27003	.046	.281	1-1/2
MAG27004	.050	.281	1-1/2
MAG27005	.055	.359	1-1/2
MAG27194*	.050	.312	1-1/2
MAG27195*	.055	.359	1-1/2
MAG27196*	.064	.500	1-3/4

\*5/16" SHANK

SLOTTED POWER BITS - 1/4" SHANK



STOCK NO.	BLADE THICKNESS	BLADE WIDTH	OVERALL LENGTH
MAG27472	.034	.187	2-3/4
MAG27473	.036	.215	2-3/4
MAG27474	.038	.250	2-3/4
MAG27475	.042	.275	2-3/4
EV288S	.042	.275	6"
MAG27476	.046	.312	2-3/4

SLOTTED POWER BITS W/FINDERS  
1/4" HEX SHANK



STOCK NO.	BLADE THICKNESS	BLADE WIDTH	OVERALL LENGTH
MAG39625	.036	.193	3-3/4
MAG39626	.040	.241	3-3/4
MAG39627	.042	.290	3-3/4
MAG39628	.046	.350	3-3/4

TORX INSERT BITS



STOCK NO.	POINT SIZE	HEX SHANK	OVERALL LENGTH
MAG37151	T7	1/4	1"
MAG37153	T8	1/4	1"
MAG37155	T9	1/4	1"
MAG37157	T10	1/4	1"
MAG37159	T15	1/4	1"
MAG37161	T20	1/4	1"
MAG37163	T25	1/4	1"
MAG37165	T27	1/4	1"
MAG37167	T30	1/4	1"
MAG37169	T40	1/4	1"
MAG37171	T30	5/16	1-1/4
MAG37173	T40	5/16	1-1/4
MAG37175	T45	5/16	1-1/4
MAG37177	T50	5/16	1-1/4
QUAL61T55	T55	5/16	1-1/4

TORX TAMPER PROOF INSERT BITS  
5/16" HEX SHANK



STOCK NO.	POINT SIZE	HEX SHANK	OVERALL LENGTH
MAG35690	T30	5/16	1-1/4
MAG35691	T40	5/16	1-1/4
MAG35380	T45	5/16	1-1/4
MAG35381	T50	5/16	1-1/4
MAG35382	T55	5/16	1-1/4

SQUARE RECESS INSERT BITS  
1/4" HEX SHANK



STOCK NO.	POINT SIZE	OVERALL LENGTH
EV250R0	#0	1"
MAG29049	#1	1"
MAG29050	#2	1"
MAG29051	#3	1"

DOUBLE END BITS  
1/4" SHANK

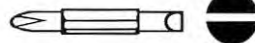

PHILLIPS SIZE #2 AND SLOTTED SIZE #8

STOCK NO. EVDEB28

SOCKET HEAD INSERT BITS



STOCK NO.	POINT SIZE	OVERALL LENGTH
MAG27097	3/32	1"
MAG37475	7/64	1"
MAG27098	1/8	1"
MAG37476	9/64	1"
MAG27099	5/32	1"
MAG27100	3/16	1"
MAG27102	1/4	1"
MAG27103	5/16	1"

SQUARE RECESS POWER BITS  
1/4" HEX SHANK



STOCK NO.	POINT SIZE	OVERALL LENGTH	NO. SIZE
MAG29052	#1	2"	2"
MAG29053	#2	2"	2"
MAG29054	#3	2"	2"
MAG45186*	#3	2"	2"

\*ISOTEMP BIT

ISOTEMP PHILLIPS POWER BITS



THE INTERLOCKING RIBS OF THE ANTI-CAM-OUT SYSTEM PROVIDE HIGHER TORQUE. LASTS UP TO SIX TIMES LONGER THAN EXTRA-HARD BITS.

STOCK NO.	POINT SIZE	BODY DIA.	OVERALL LENGTH
MAG45327	#2	1/4	2"
MAG45328	#3	1/4	2"

SPANNER INSERT BITS



STOCK NO.	POINT SIZE	BODY DIA.	OVERALL LENGTH
EV312SPB6	#6	5/16	1-1/2
EV312SPB8	#8	5/16	1-1/2
EV312SPB10	#10	5/16	1-1/2
EV312SPB14	#14	5/16	1-1/2

UN-DO-IT TOOL



STOCK NO.	SCREW SIZES
804	6-8
807	10-12
TPS810	1/4

ADDITIONAL ITEMS AVAILABLE UPON REQUEST

### POWER BIT ACCESSORIES

#### MAGNETIC NUTSETTERS

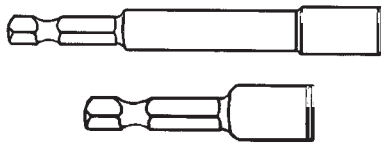

1/4" HEX SHANK - SHORT LENGTH

STOCK NO.	HEX SIZE	BODY DIA.	OVERALL LENGTH
MAG31450	1/4	7/16	1-5/8
MAG31452	5/16	1/2	1-5/8
MAG36165	3/8	9/16	1-3/4
EVMSH716	7/16	9/16	1-3/4
EVMSH12	1/2	3/4	1-3/4

1/4" HEX SHANK - LONG LENGTH

STOCK NO.	HEX SIZE	BODY DIA.	OVERALL LENGTH
MAG37582	1/4	7/16	2-9/16
MAG37583	5/16	1/2	2-9/16
MAG37584	3/8	9/16	2-9/16
MAG38639	7/16	9/16	2-9/16

#### MAGNETIC INSERT BIT HOLDERS

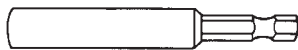

STOCK NO.	INSERT BIT SIZE	BODY DIA.	OVERALL LENGTH
MAG40831	1/4	7/16	2-1/8
MAG40833	1/4	7/16	3"
MAG27792	1/4	7/16	12"
QUAL4MBH516	5/16	1/2	3"

#### FRICTION NUT INSERT BIT HOLDER SOCKETS



STOCK NO.	INSERT BIT SIZE	SQUARE DRIVE	OVERALL LENGTH
MAG31894	1/4	1/4	1-1/8
MAG31895	1/4	3/8	1-1/8
MAG31896	5/16	3/8	1-3/8

#### FRICTION NUT INSERT BIT HOLDERS



STOCK NO.	INSERT BIT SIZE	BODY DIA.	OVERALL LENGTH
MAG31889	1/4	3/8	2-7/16
MAG31890	1/4	3/8	4"
MAG31891	1/4	3/8	6"

ADDITIONAL ITEMS AND SIZES AVAILABLE UPON REQUEST

#### POWER DRIVE EXTENSIONS



STOCK NO.	HEX SIZE	DRIVE	OVERALL LENGTH
MAG34610	1/4	1/4	2"
MAG37570	1/4	1/4	3"
MAG31594	1/4	1/4	4"
MAG31595	1/4	1/4	6"
MAG34611	1/4	3/8	2"
MAG38209	1/4	3/8	3"

#### MAGNETIC SOCKETS

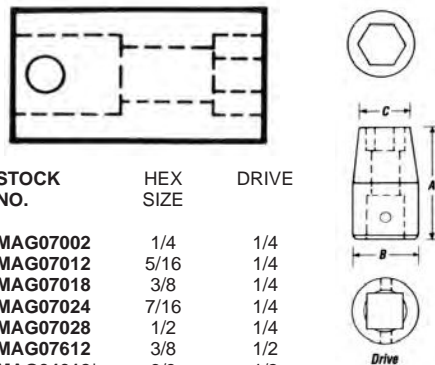

STOCK NO.	HEX SIZE	DRIVE
MAG07002	1/4	1/4
MAG07012	5/16	1/4
MAG07018	3/8	1/4
MAG07024	7/16	1/4
MAG07028	1/2	1/4
MAG07612	3/8	1/2
MAG04612*	3/8	1/2

\*NON-MAGNETIC

#### NON-MAGNETIC BIT HOLDERS

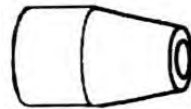

STOCK NO.	SQUARE DRIVE	HEX SHANK	OVERALL LENGTH
EV500BH14	1/2	1/4	1-1/2
EV500BH516	1/2	5/16	1-3/4

#### MAGNETIC SCREWDRIVER

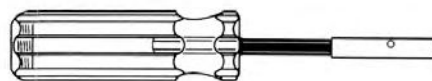

WITHOUT BITS  
1/4" & 5/16" BIT SIZE - 8" OVERALL LENGTH

STOCK NO. EVMHD14 (1/4")  
STOCK NO. EVMHD516 (5/16")

#### POWER BIT QUICK-CHANGE CHUCK

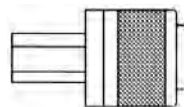

CONVERT YOUR 3/8" SPEED CONTROL DRILL TO A 1/4" "QUICK CHANGE" POWER SCREW GUN. THIS WILL ALSO ALLOW "QUICK CHANGE" OF 1/4" HEX POWER BITS IN SINGLE SPEED DRILLS.

STOCK NO. EV1001 (3/8" SHANK)

#### 29-PIECE SCREWDRIVER BIT SET



INCLUDES 1/4" MAGNETIC DRIVER WITH STORAGE HANDLE, PHILLIPS BITS 0-3, SLOTTED BITS 0, 1, 3, 4, 5, 6, 8, 10, 12, ALLEN BITS 5/64, 3/32, 7/64, 1/8, 9/64, SQUARE RECESS BITS 0-3, TORX BITS T10, T15, T20, T25, T30, T40, POSI-DRIVE BITS 1 & 2, 1/4" SOCKET ADAPTER, 1/4" BIT HOLDER (FOR USE WITH POWER TOOLS). HANDY CARRYING CASE.

STOCK NO. EV29BK

#### SECURITY WRENCHES



SOCKET PIN-HEAD KEY		TORX PIN-HEAD KEY	
STOCK NO.	SIZE	STOCK NO.	SIZE
TPS50	3/32	QUAL69TR10	#10
TPS51	1/8	QUAL69TR15	#15
TPS52	9/64	QUAL69TR20	#20
TPS53	5/32	QUAL69TR25	#25
TPS54	3/16	QUAL69TR27	#27
TPS55	7/32	QUAL69TR30	#30
TPS56	1/4	QUAL69TR40	#40
TPS57	5/16		

OVER BREAKFAST ONE MORNING, A WOMAN SAID TO HER HUSBAND, "I BET YOU DON'T KNOW WHAT DAY THIS IS."

"OF COURSE I DO," HE INDIGNANTLY ANSWERED, GOING OUT THE DOOR ON HIS WAY TO THE OFFICE.

AT 10 AM, THE DOORBELL RANG, AND WHEN THE WOMAN OPENED THE DOOR, SHE WAS HANDED A BOX CONTAINING A DOZEN LONG-STEMMED RED ROSES. AT 1 PM, A FOIL-WRAPPED, TWO POUND BOX OF HER FAVORITE CHOCOLATES ARRIVED. LATER, A BOUTIQUE DELIVERED A DESIGNER DRESS.

"THE WOMAN COULDN'T WAIT FOR HER HUSBAND TO COME HOME. "FIRST THE FLOWER, THEN THE CANDY, AND THEN THE DRESS!" SHE EXCLAIMED. "I'VE NEVER SPENT A MORE WONDERFUL GROUNDHOG DAY IN MY WHOLE LIFE!"



**THE NEW WRIGHT WRENCH**



ADVANCED TOOL PREPARATION AND HEAT-TREATING PROCESS OF CHROME MOLY ALLOY STEEL PROVIDES EXTRA TOUGHNESS. SMOOTH, SCULPTURED DESIGN PREVENTS CHROME CRACKING AND PEELING. HOT-FORGED FOR EXCELLENT METAL GRAIN FLOW, WHICH PROVIDES CONSISTENCY IN STRENGTH. LARGE NUMBERS ENABLE EASY-TO-READ SIZE IDENTIFICATION. CAD/CAM TECHNOLOGIES PROVIDE THE MOST SCIENTIFICALLY ADVANCED WRENCH DESIGN THAT'S ARTFULLY SCULPTURED FOR BEAUTIFUL APPEARANCE. PATENTED WRIGHT DRIVE TOOL DESIGN PROVIDES 10 TIMES MORE CONTACT AREA ON FASTENERS THAN CONVENTIONAL 12-POINT WRENCHES.

**WRIGHT TOOL**

**1100 SERIES COMBINATION**



**WRENCHES-12 PT.**

WRIGHT'S 1100 STANDARD SERIES WRENCHES ARE SPECIALLY DESIGNED FOR TODAY'S MECHANIC WHO NEEDS A HARD WORKING, DEPENDABLE TOOL ON THE JOB. LIKE ALL WRIGHT WRENCHES, THEY ARE QUALITY BUILT FOR LONG-LASTING PERFORMANCE.

STOCK NO.	DESCRIPTION	STOCK NO.	DESCRIPTION
WT1108	1/4	WT1140	1-1/4
WT1110	5/16	WT1142	1-5/16
PROTO1211*	11/32	WT1144	1-3/8
WT1112	3/8	WT1146	1-7/16
WT1114	7/16	WT1148	1-1/2
WT1116	1/2	WT1152*	1-5/8
WT1118	9/16	WT1154*	1-11/16
WT1120	5/8	WT1156*	1-3/4
WT1122	11/16	WT1158*	1-13/16
WT1124	3/4	WT1160*	1-7/8
WT1126	13/16	WT1164*	2"
WT1128	7/8	1166	2-1/16
WT1130	15/16	WT1168*	2-1/8
WT1132	1"	1170	2-3/16
WT1134	1-1/16	WT1172*	2-1/4
WT1136	1-1/8	WT1176*	2-3/8
WT1138	1-3/16	WT1180*	2-1/2

\*NOT WRIGHT BRAND

**COMBINATION WRENCHES**

**METRIC COMBINATION WRENCHES**



STOCK NO.	DESCRIPTION	STOCK NO.	DESCRIPTION
1107MM	7MM	WT1120MM	20MM
WT1108MM	8MM	1121MM	21MM
WT1109MM	9MM	WT1122MM	22MM
WT1110MM	10MM	1123MM	23MM
WT1111MM	11MM	WT1124MM	24MM
WT1112MM	12MM	WT1125MM	25MM
WT1113MM	13MM	WT1126MM	26MM
WT1114MM	14MM	WT1127MM	27MM
WT1115MM	15MM	WT1130MM	30MM
WT1116MM	16MM	WT1132MM	32MM
WT1117MM	17MM	WT1136MM	36MM
WT1118MM	18MM	WT1141MM*	41MM
WT1119MM	19MM	WT1146MM*	46MM
		WT1150MM*	50MM

\*NOT WRIGHT BRAND

**12 PT. BOX END WRENCHES  
45 DEGREE DOUBLE OFFSET**

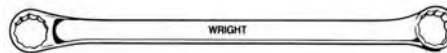

STOCK NO.	DESCRIPTION
WT51214	3/8 x 7/16
WT51618	1/2 x 9/16
WT52022	5/8 x 11/16
WT52428	3/4 x 7/8
WT52830	7/8 x 15/16

**OPEN END WRENCHES**

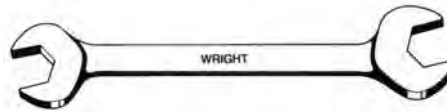

STOCK NO.	DESCRIPTION
1310	1/4 x 5/16
WT1314	3/8 x 7/16
WT1318	1/2 x 9/16
WT1322	5/8 x 11/16
1326	3/4 x 13/16
1329	13/16 x 7/8
1330	7/8 x 15/16



**MINIATURE COMBINATION WRENCH SET - 10 PIECES**



SET NO.	DESCRIPTION
WT787	5/32 x 3/16
	3/16 x 5/32
	13/64 x 7/32
	7/32 x 15/64
	15/64 x 1/4
	1/4 x 9/32
	9/32 x 5/16
	5/16 x 11/32
	11/32 x 3/8
	3/8 x 7/16

SUPPLIED IN PLASTIC POUCH

**MINIATURE OPEN END WRENCH SET - 8 PIECES**



SET NO.	DESCRIPTION
WT798	7/32 x 7/32
	15/64 x 15/64
	1/4 x 1/4
	9/32 x 9/32
	5/16 x 5/16
	11/32 x 11/32
	3/8 x 3/8
	7/16 x 7/16

SUPPLIED IN PLASTIC POUCH



**COMBINATION WRENCH SETS  
WITH COTTON DENIM TOOL ROLL**



**STOCK NO. WT707 7 PIECES**

PART NO.	DESCRIPTION	PART NO.	DESCRIPTION
	12PT. COMBINATION WRENCHES		12PT. COMBINATION WRENCHES
1112	3/8"	1120	5/8"
1114	7/16"	1122	11/16"
1116	1/2"	1124	3/4"
1118	9/16"	707R	TOOL ROLL



**STOCK NO. WT714 14 PIECES**

PART NO.	DESCRIPTION	PART NO.	DESCRIPTION
	12PT. COMBINATION WRENCHES		12PT. COMBINATION WRENCHES
1112	3/8"	1128	7/8
1114	7/16"	1130	15/16
1116	1/2"	1132	1"
1118	9/16"	1134	1-1/16
1120	5/8"	1136	1-1/8
1122	11/16"	1140	1-1/4
1124	3/4"	714R	TOOL ROLL
1126	13/16"		



**STOCK NO. WT736 6 PIECES**

PART NO.	DESCRIPTION	PART NO.	DESCRIPTION
	OPEN END WRENCHES		OPEN END WRENCHES
1310	1/4 x 5/16	1326	3/4 x 13/16
1314	3/8 x 7/16	1330	7/8 x 15/16
1318	1/2 x 9/16	736R	TOOL ROLL
1322	5/8 x 11/16		



**STOCK NO. WT711 11 PIECES**

PART NO.	DESCRIPTION	PART NO.	DESCRIPTION
	12PT. COMBINATION WRENCHES		12PT. COMBINATION WRENCHES
1112	3/8"	1124	3/4
1114	7/16"	1126	13/16
1116	1/2"	1128	7/8
1118	9/16"	1130	15/16
1120	5/8"	1132	1"
1122	11/16"	711R	TOOL ROLL



**STOCK NO. WT750 11 PIECES**

**12PT. METRIC COMBINATION WRENCHES**

PART NO.	DESCRIPTION	PART NO.	DESCRIPTION
11-07MM	7MM	11-13MM	13MM
11-08MM	8MM	11-14MM	14MM
11-09MM	9MM	11-15MM	15MM
11-10MM	10MM	11-17MM	17MM
11-11MM	11MM	11-19MM	19MM
11-12MM	12MM	711R	TOOL ROLL



**STOCK NO. WT743 3 PIECES**

PART NO.	DESCRIPTION	PART NO.	DESCRIPTION
	FLARE NUT WRENCHES		FLARE NUT WRENCHES
1614	3/8 x 7/16	1622	5/8 x 11/16
1618	1/2 x 9/16	743R	TOOL ROLL

**CALL TO PLACE AN ORDER**



**CALL TO PLACE AN ORDER**





**JET BRAND  
ECONOMY WRENCH SETS**

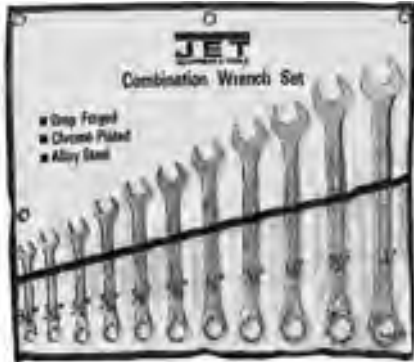

11 PC. COMBINATION WRENCH SET PICTURED

DROP FORGED ALLOY STEEL, HEAT-TREATED AND HARDENED, CHROME-PLATED AND POLISHED. VINYL POUCH.

**6 PC. COMBINATION WRENCH SET**

PART NO.	SIZE	PART NO.	SIZE
477423	3/8	477426	9/16
477424	7/16	477427	5/8
477425	1/2	477429	3/4

STOCK NO. JET477406

**11 PC. COMBINATION WRENCH SET**

PART NO.	SIZE	PART NO.	SIZE
477423	3/8	477428	11/16
477424	7/16	477429	3/4
477425	1/2	477430	13/16
477426	9/16	477431	7/8
477427	5/8	477432	15/16
		477433	1"

STOCK NO. JET477411

**14 PC. COMBINATION WRENCH SET**

PART NO.	SIZE	PART NO.	SIZE
477423	3/8	477430	13/16
477424	7/16	477431	7/8
477425	1/2	477432	15/16
477426	9/16	477433	1"
477427	5/8	477434	1-1/16
477428	11/16	477435	1-1/8
477429	3/4	477436	1-1/4

STOCK NO. JET477414

CUSTOMER SATISFACTION  
IS THE KEY  
TO OUR SUCCESS

**COMBINATION WRENCH SETS  
SPECIALTY & ADJUSTABLE WRENCHES**



**RATCHETING BOX WRENCHES\***



STOCK NO.	DESCRIPTION	STOCK NO.	DESCRIPTION
WT9381	1/4 x 5/16	WT9384	5/8 x 11/16
WT9382	3/8 x 7/16	WT9386	3/4 x 7/8
WT9383	1/2 x 9/16		

\*NOT WRIGHT BRAND

**5PC. RATCHETING BOX WRENCH SET**



SET NO.	DESCRIPTION
KARB5	1/4 x 5/16 3/8 x 7/16 1/2 x 9/16 5/8 x 11/16 3/4 x 7/8

COMES IN PLASTIC POUCH

**3/8 DRIVE CROWFOOT WRENCHES**



STOCK NO.	DESCRIPTION	STOCK NO.	DESCRIPTION
1012	3/8	WT1022	11/16
WT1014	7/16	WT1024	3/4
WT1016	1/2	1026	13/16
WT1018	9/16	1028	7/8
WT1020	5/8	1032	1"

1/2" DR. CROWFOOT AND METRIC CROWFOOT  
AVAILABLE PER REQUEST

**1/2 DRIVE  
CRAWFOOT FLARE WRENCH**



STOCK NO.	DESCRIPTION
WT1074*	1-1/16
WT1080	1-1/8
WT1081	1-3/16
WT1082	1-1/4
WT1083	1-5/16
WT1084	1-3/8
WT1085	1-7/16
WT1086	1-1/2

\*3/8 DRIVE

**STRIKING WRENCHES**



**WRIGHT TOOL HEAVY DUTY 12PT.  
STRIKING FACE WRENCHES**

- HANDLE OFFSET FROM BOX HEAD TO CLEAR OBSTRUCTIONS
- LARGE STRIKING SURFACE FOR SURE CONTACT
- SIZE AND PART NUMBER CLEARLY MARKED ON EACH WRENCH
- EXTRA DEEP BOX HEAD SECURELY ENGAGES FASTENER
- BOX OPENING UNDERSIDE IS CHAMFERED TO PERMIT EASY PLACEMENT OVER BOLT HEAD OR NUT

PART NO.	DESCRIPTION	PART NO.	DESCRIPTION
1932	1"	1968	2-1/8
1934	1-1/16	1970	2-3/16
1936	1-1/8	1972	2-1/4
1940	1-1/4	1974	2-5/16
1942	1-5/16	1976	2-3/8
1946	1-7/16	1980	2-1/2
1948	1-1/2	1982	2-9/16
1952	1-5/8	1984	2-5/8
1954	1-11/16	1988	2-3/4
1958	1-13/16	1996	3"
1960	1-7/8	1997	3-1/8
1962	1-5/16		
1964	2"		

\*NON-STOCKED ORDERED BY REQUEST

**ADJUSTABLE WRENCHES  
CHROME FINISH**

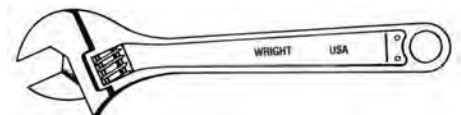

STOCK NO.	DESCRIPTION	LENGTH	MAX CAPACITY
WT9AC04	4"	4"	1/2
WT9AC06	6"	6"	15/16
WT9AC08	8"	8"	1-1/8
WT9AC10	10"	10"	1-3/8
WT9AC12	12"	12"	1-1/2
WT9AC15	15"	15"	1-11/16
WT9AB18*	18"	18"	2-1/8
WT9AB24*	24"	24"	2-17/32

\*BLACK FINISH

**A LARGE VARIETY  
OF TOOLS  
FOR A LARGE VARIETY  
OF APPLICATIONS**



**WRIGHT TOOL**

**DRIVE SOCKETS**



**WRIGHT TOOL**

**DRIVE SOCKETS PROVIDE TEN TIMES MORE SOCKET-TO-FASTENER CONTACT AREA THAN CONVENTIONAL SOCKETS...**  
 THE WRIGHT DRIVE SPREADS CONTACT STRESS



MORE EVENLY THAN ANY OTHER SOCKET SYSTEM AVAILABLE. ITS UNIQUE DESIGN HAS BEEN AWARDED PATENT #4,882,957. IT IS FULLY CERTIFIED FOR 12-POINT AEROSPACE FASTENERS UNDER AS954 SPECIFICATIONS. WRIGHT DRIVE SOCKETS ARE MADE IN AMERICA WITH AMERICAN 4140 ALLOY STEEL.

**WRIGHT TOOL**

**1/4" DRIVE SOCKETS  
6 PT. - STANDARD**



STOCK NO.	SIZE OPENING (INCHES)
WT2006	3/16
WT2007	7/32
WT2008	1/4
WT2009	9/32
SK40909*	9/32
WT2010	5/16
WT2011	11/32
WT2012	3/8
WT2014	7/16
WT2016	1/2

\*NOT WRIGHT BRAND

STOCK NO.	SIZE OPENING (METRIC)
2005MM	5MM
2006MM	6MM
2007MM	7MM
2008MM	8MM
2009MM	9MM
2010MM	10MM
2011MM	11MM
2012MM	12MM
2013MM	13MM

**1/4" DRIVE SOCKETS  
6 PT. - DEEP**



STOCK NO.	SIZE OPENING (INCHES)
WT2508	1/4
WT2509	9/32
WT2510	5/16
WT2511	11/32
WT2512	3/8
WT2514	7/16
WT2516	1/2

STOCK NO.	SIZE OPENING (METRIC)
2505MM	5MM
2506MM	6MM
2507MM	7MM
2508MM	8MM
2509MM	9MM
2510MM	10MM
2511MM	11MM
2512MM	12MM
2513MM	13MM

**ADDITIONAL ITEMS AVAILABLE UPON REQUEST**

**OVER 30,000  
INVENTORY ITEMS IN STOCK!**



**1/4" DRIVE SOCKETS  
12 PT. - STANDARD**



STOCK NO.	DESCRIPTION
2106	3/16
2107	7/32
2108	1/4
2109	9/32
2110	5/16
2111	11/32
2112	3/8
2114	7/16
2116	1/2
2118	9/16

**1/4" DRIVE SOCKETS  
12 PT. - DEEP**



STOCK NO.	DESCRIPTION
2606	3/16
2607	7/32
2608	1/4
2609	9/32
2610	5/16
2611	11/32
2612	3/8
2614	7/16
2616	1/2
2618	9/16

**1/4" DRIVE HEX SOCKETS WITH BITS**



STOCK	DESCRIPTION	STOCK	DESCRIPTION
2202	1/16	2207	9/64
2203	5/64	2208	5/32
2204	3/32	2210	3/16
2205	7/64	2212	7/32
2206	1/8	2214	1/4
		2218	5/16



**RATCHET**

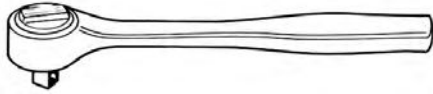

HEAD DIAMETER ONLY 25/32". HANDLE SWINGS IN 3/4" ARC TO GET THE NEXT BITE. WORKS IN THE TIGHTEST PLACES. 45 TEETH.

STOCK NO.	DESCRIPTION
WT2426	4-3/4" LENGTH

**FLEX HEAD RATCHET/HANDLE**

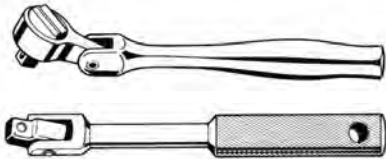

STOCK NO.	DESCRIPTION
2495	RATCHET- 45 TEETH- 5-1/2"
2435	5" FLEX HANDLE (BREAKER BAR)

**1/4" DRIVE SOCKET SET  
 6 PT. - 12 PIECE**

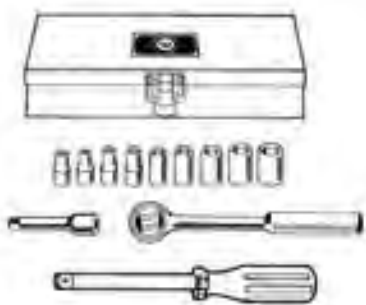

STOCK NO.	DESCRIPTION
WT212	
6PT. STD. SOCKETS	
2006	3/16
2007	7/32
2008	1/4
2009	9/32
2010	5/16
2011	11/32
2012	3/8
2014	7/16
2016	1/2
2400	RATCHET
2402	2" EXTENSION
2441	SPINNER
90	METAL BOX

**1/4" DRIVE SOCKETS,  
 HANDLES & ATTACHMENTS**

**1/4" DRIVE SOCKET SET  
 6 PT. STANDARD & 6 PT. DEEP  
 23 PIECES**

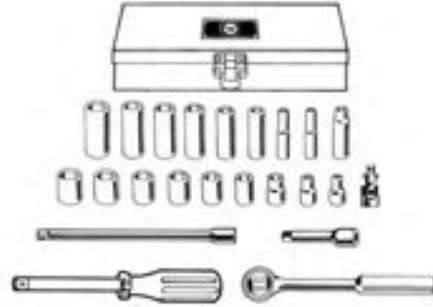

STOCK NO.	DESCRIPTION
223	
6PT. STD. SOCKET	
2205	5/32
2006	3/16
2007	7/32
2008	1/4
2009	9/32
2010	5/16
2011	11/32
2012	3/8
2014	7/16
2016	1/2
6PT. DEEP SOCKET	
2506	3/16
2508	1/4
2509	9/32
2510	5/16
2511	11/32
2512	3/8
2514	7/16
2516	1/2
2426	RATCHET, 4-3/4"
2402	EXTENSION, 2"
2406	EXTENSION, 6"
2441	SPINNER
2475	UNIVERSAL
88	METAL BOX

**1/4" DRIVE SOCKET SET  
 12 PT. DEEP - 10 PIECES**



STOCK NO.	DESCRIPTION
210	
12PT. DEEP SOCKETS	
2606	3/16
2607	7/32
2608	1/4
2609	9/32
2610	5/16
2611	11/32
2612	3/8
2614	7/16
2616	1/2
2618	9/16
82	METAL TRAY



**1/4" DRIVE SOCKET  
 6 PT. STANDARD METRIC SET**

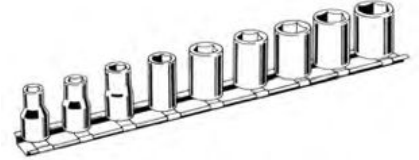

STOCK NO. 256	DESCRIPTION
6 PT. STD. SOCKETS	
2005MM	5MM
2006MM	6MM
2007MM	7MM
2008MM	8MM
2009MM	9MM
2010MM	10MM
2011MM	11MM
2012MM	12MM
2013MM	13MM
244	CLIP RAIL

**EXTENSIONS**



STOCK NO.	DESCRIPTION
WT2402	2" EXTENSION
WT2406	6" EXTENSION
2414	14" EXTENSION

**UNIVERSAL**

BUILT IN SPRING TENSION FOR EASY APPLICATION TO NUT. NO BINDING OR LOCKED JOINTS-NO SHARP CORNERS.



STOCK NO.	DESCRIPTION
WT2475	UNIVERSAL

**ADAPTER**



STOCK NO.	DESCRIPTION
WT2453	1/4 F x 3/8 M

**RENEWAL KIT**



FOR 2400 RATCHET. ONE PIECE, FOOLPROOF. SIMPLY REMOVE THE SNAP RING AND DROP A NEW KIT INTO PLACE. ON THE SPOT REPAIRS. EXTENDS THE LIFE OF THE RATCHET.

STOCK NO.	DESCRIPTION
WT2401	RATCHET RENEWAL KIT

**SPINNER HANDLE W/ PLASTIC GRIP**



STOCK NO.	DESCRIPTION
WT2441	SPINNER HANDLE



3/8" DRIVE SOCKETS



3/8" DRIVE IMPACT SOCKETS  
6 PT STANDARD  
SAE

STOCK NO.	SIZE OPENING
3810	5/16
3812	3/8
<b>WT3814</b>	<b>7/16</b>
3816	1/2
3818	9/16
3820	5/8
3822	11/16
3824	3/4



3/8" DRIVE IMPACT SOCKETS  
6 PT STANDARD UNIVERSAL  
SAE

STOCK NO.	SIZE OPENING
3852	3/8
3854	7/16
3856	1/2
3858	9/16
3860	5/8
3862	11/16
3864	3/4



6 PT STANDARD  
METRIC

STOCK NO.	SIZE OPENING
3806MM	6MM
3807MM	7MM
3808MM	8MM
3809MM	9MM
3810MM	10MM
3811MM	11MM
3812MM	12MM
3813MM	13MM
3814MM	14MM
3815MM	15MM
3816MM	16MM
3817MM	17MM
3818MM	18MM
3819MM	19MM

6PT STANDARD UNIVERSAL  
METRIC

STOCK NO.	SIZE OPENING
3849MM	9MM
3850MM	10MM
3851MM	11MM
3852MM	12MM
3853MM	13MM
3854MM	14MM
3855MM	15MM
3856MM	16MM
3857MM	17MM
3858MM	18MM
3859MM	19MM

NOT SURE  
ABOUT  
SOMETHING?  
GIVE US A  
CALL!  
ONE OF OUR  
ASSOCIATES  
WILL BE  
MORE THAN  
HAPPY TO  
HELP YOU  
OUT.

3/8" DRIVE IMPACT SOCKETS  
6 PT DEEP  
SAE

STOCK NO.	SIZE OPENING
3910	5/16
<b>WT3912</b>	<b>3/8</b>
<b>WT3914</b>	<b>7/16</b>
<b>WT3916</b>	<b>1/2</b>
<b>WT3918</b>	<b>9/16</b>
<b>WT3920</b>	<b>5/8</b>
<b>WT3922</b>	<b>11/16</b>
<b>WT3924</b>	<b>3/4</b>



3/8" DRIVE IMPACT SOCKETS  
6 PT DEEP UNIVERSAL  
SAE

STOCK NO.	SIZE OPENING
3952	3/8
3954	7/16
3956	1/2
3958	9/16
3960	5/8
3962	11/16
3964	3/4



6 PT DEEP  
METRIC

STOCK NO	SIZE OPENING
3906MM	6MM
3907MM	7MM
3908MM	8MM
3909MM	9MM
3910MM	10MM
3911MM	11MM
3912MM	12MM
3913MM	13MM
3914MM	14MM
3915MM	15MM
3916MM	16MM
3917MM	17MM
3918MM	18MM
3919MM	19MM

6 PT DEEP UNIVERSAL  
METRIC

STOCK NO.	SIZE OPENING
3949MM	9MM
3950MM	10MM
3951MM	11MM
3952MM	12MM
3953MM	13MM
3954MM	14MM
3955MM	15MM
3956MM	16MM
3957MM	17MM
3958MM	18MM
3959MM	19MM

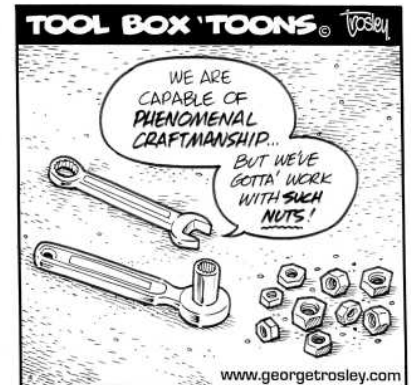



**3/8" DRIVE SOCKETS  
CHROME**



**3/8" DRIVE CHROME SOCKETS  
STANDARD**



STOCK NO. 6 PT.	12 PT.	SIZE OPENING
WT3008	WT3108	1/4
WT3010	WT3110	5/16
WT3012	3112	3/8
WT3014	3114	7/16
WT3016	3116	1/2
WT3018	3118	9/16
WT3020	WT3120	5/8
WT3022	WT3122	11/16
WT3024	WT3124	3/4
WT3026	WT3126	13/16
WT3028	3128	7/8
	WT3130	15/16
3032	WT3132	1"

**METRIC**

STOCK NO 6 PT. STD.	SIZE OPENING
WT3006MM	6MM
3007MM	7MM
WT3008MM	8MM
WT3009MM	9MM
WT3010MM	10MM
WT3011MM	11MM
WT3012MM	12MM
WT3013MM	13MM
WT3014MM	14MM
WT3015MM	15MM
WT3016MM	16MM
WT3017MM	17MM
WT3018MM	18MM
WT3019MM	19MM

**3/8" DRIVE CHROME SOCKETS  
ALLEN**

STOCK NO	SIZE OPENING
WT3204	1/8
WT3205	5/32
WT3206	3/16
WT3207	7/32
WT3208	1/4
WT3210	5/16
WT3212	3/8



**METRIC**

STOCK NO	SIZE OPENING
3202MM	2MM
32025MM	2.5MM
3203MM	3MM
WT3204MM	4MM
WT3205MM	5MM
WT3206MM	6MM
WT3208MM	8MM
WT3210MM	10MM

**3/8" DRIVE CHROME SOCKETS  
ALLEN WITH LONG BITS**

STOCK NO.	SIZE OPENING	BIT LENGTH
WT32L06	3/16	5-1/16
WT32L08	1/4	5-1/16
WT32612	3/8	5-5/64



**3/8" DRIVE CHROME SOCKETS  
6 PT SPARK PLUGS**

STOCK NO.	SIZE OPENING
WT3590	5/8
WT3596	13/16



**3/8" DRIVE CHROME SOCKETS  
DEEP 6 PT**

STOCK NO.	SIZE OPENING
WT3510	5/16
WT3512	3/8
WT3514	7/16
WT3516	1/2
WT3518	9/16
WT3520	5/8
WT3522	11/16
WT3524	3/4
WT3526	13/16
3528	7/8



**METRIC**

STOCK NO.	SIZE OPENING
3506MM	6MM
3507MM	7MM
WT3508MM	8MM
3509MM	9MM
WT3510MM	10MM
WT3511MM	11MM
WT3512MM	12MM
WT3513MM	13MM
WT3514MM	14MM
3515MM	15MM
3516MM	16MM
WT3517MM	17MM
WT3518MM	18MM
3519MM	19MM

**3/8" DRIVE CHROME SOCKETS  
FLEX 6 PT**

STOCK NO.	SIZE OPENING
3712	3/8
3714	7/16
3716	1/2
3718	9/16
3720	5/8
3722	11/16
3724	3/4



*SAVE TIME  
AND MONEY!  
TO SAVE  
OUR  
CUSTOMERS  
THE DELAY  
AND BOTHER  
OF HUNTING  
THROUGH  
MANY  
SOURCES  
OF SUPPLY,  
WE CAN  
FURNISH  
MANY ITEMS  
NOT LISTED  
IN THIS  
CATALOG.*

**ADDITIONAL ITEMS AVAILABLE  
UPON REQUEST**



**3/8" DRIVE HANDLES, ATTACHMENTS & SOCKET SETS**



**3/8" DRIVE SCREWDRIVER SOCKETS WITH BITS**



SLOTTED		PHILLIPS	
STOCK NO.	DESCRIPTION	STOCK NO.	DESCRIPTION
WT3260	1/4	3265	#1
3261	5/16	WT3266	#2
WT3262	3/8	WT3267	#3
		3268	#4

**FLEX HANDLES**

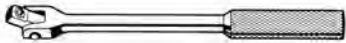

PARTS ARE CHROME PLATED PRIOR TO ASSEMBLY TO ELIMINATE RUSTING.

STOCK NO.	DESCRIPTION
WT3435	FLEX-KNURLED STEEL HANDLE
WT3438	FLEX-NITRILE HANDLE

**SPEEDER HANDLE**



STOCK NO.	DESCRIPTION
WT3445	14-1/2" LONG

**3/8" DR. SCREWDRIVER SOCKET SET**

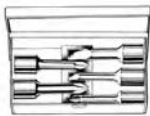

SET NO. 306 - 5 PIECES

STOCK NO.	DESCRIPTION
WT306	SCREWDRIVER SOCKET
3266	PHILLIPS #2
3267	PHILLIPS #3
3268	PHILLIPS #4
3260	BLADE 1/4
3262	BLADE 3/8
97	METAL BOX

THE WAY I SEE IT, IF YOU WANT THE RAINBOW, YOU GOTTA PUT UP WITH THE RAIN.  
--DOLLY PARTON

**3/8" & 1/2" DRIVE HEX BIT SOCKET SET**



SET NO. 311 - 10 PIECES

STOCK NO.	DESCRIPTION	STOCK NO.	DESCRIPTION
WT311	3/8" DRIVE SOCKETS W/ BITS		1/2" DRIVE SOCKETS W/ BITS
3204	1/8	4216	1/2
3205	5/32	4218	9/16
3206	3/16	4220	5/8
3207	7/32	226	PLASTIC BOX
3208	1/4		
3210	5/16		
3212	3/8		

**3/8" DRIVE HEX BIT SOCKET SET**



SET NO. 305 - 7PIECES

STOCK NO.	DESCRIPTION
WT305	3/8" DRIVE SOCKETS WITH BITS
3204	1/8
3205	5/32
3206	3/16
3207	7/32
3208	1/4
3210	5/16
3212	3/8

**3/8" DRIVE HEX BIT METRIC SOCKET SET**



SET NO. 353 8 PIECES

STOCK NO.	DESCRIPTION
WT353	ALLEN TYPE METRIC SOCKETS W/ BITS INCLUDES:
3202MM	2MM
3202.5MM	2.5MM
3203MM	3MM
3204MM	4MM
3205MM	5MM
3206MM	6MM
3208MM	8MM
3210MM	10MM
227	PLASTIC BOX

**3/8" DRIVE REPLACEMENT HEX BITS**

STANDARD STOCK NO.	SIZE	METRIC STOCK NO.	SIZE
WT3204B	1/8	32M02B	2MM
WT3205B	5/32	32M25B	2.5MM
WT3206B	3/16	32M03B	3MM
WT3207B	7/32	32M04B	4MM
WT3208B	1/4	32M05B	5MM
WT3210B	5/16	WT32M06B	6MM
WT3212B	3/8	32M07B	7MM
		32M08B	8MM
		32M10B	10MM

**3/8" DRIVE 6 PT. STD. SOCKET SET**



SET NO. 312 - 11 PIECES

STOCK NO.	DESCRIPTION	STOCK NO.	DESCRIPTION
WT312	6PT. STD. SOCKETS		
3008	1/4	3020	5/8
3010	5/16	3022	11/16
3012	3/8	3024	3/4
3014	7/16	3026	13/16
3016	1/2	3028	7/8
3018	9/16	W010	RAIL
		W3	11 CLIPS

**3/8" DRIVE 12 PT. STD. SOCKET SET**



SET NO. 378 - 10 PIECES

STOCK NO.	DESCRIPTION	STOCK NO.	DESCRIPTION
378	12 PT. STD. SOCKET		
3110	5/16	3120	5/8
3112	3/8	3122	11/16
3114	7/16	3124	3/4
3116	1/2	3126	13/16
3118	9/16	3128	7/8
		W010	RAIL
		W3	10 CLIPS

**3/8" DRIVE 6 PT. STD. METRIC SOCKET SET**



SET NO. 354 - 14 PIECES

STOCK NO.	DESCRIPTION	STOCK NO.	DESCRIPTION
WT354	6PT. STD. METRIC SOCKETS		
3006MM	6MM	3014MM	14MM
3007MM	7MM	3015MM	15MM
3008MM	8MM	3016MM	16MM
3009MM	9MM	3017MM	17MM
3010MM	10MM	3018MM	18MM
3011MM	11MM	3019MM	19MM
3012MM	12MM	W010	RAIL
3013MM	13MM	W3	14 CLIPS



**3/8" DRIVE SOCKET SETS**



**3/8" DRIVE 6 PT. DEEP SOCKET SET**



SET NO. 304 - 9 PIECES

STOCK NO.	DESCRIPTION	STOCK NO.	DESCRIPTION
WT304	6 PT. DEEP SOCKETS		
3512	3/8	3522	11/16
3514	7/16	3524	3/4
3516	1/2	3526	13/16
3518	9/16	3528	7/8
3520	5/8	W010	RAIL
		W3	9 CLIPS

**3/8" DRIVE 6 PT. AND 12 PT. STD. SOCKET SET**

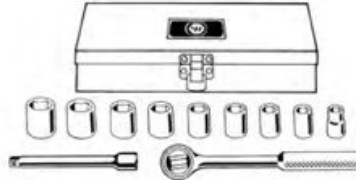

SET NO. 327 - 11 PIECES

STOCK NO.	DESCRIPTION	STOCK NO.	DESCRIPTION
WT327	6 PT. STD. SOCKETS		
3012	3/8	3024	3/4
3014	7/16	3026	13/16
3016	1/2	3028	7/8
3018	9/16	3426	RATCHET
3020	5/8	3405	5" EXTENSION
3022	11/16	W408	METAL BOX

**3/8" DRIVE 6 PT. STD. SOCKET SET**

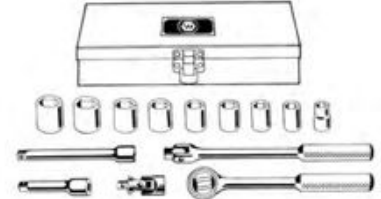

SET NO. 335 - 14 PIECES

STOCK NO.	DESCRIPTION	STOCK NO.	DESCRIPTION
WT335	6 PT. STD. SOCKETS		
3012	3/8	3028	7/8
3014	7/16	3426	RATCHET
3016	1/2	3403	3" EXTENSION
3018	9/16	3405	5" EXTENSION
3020	5/8	3435	FLEX HANDLE
3022	11/16	3475	UNIVERSAL
3024	3/4	3026	13/16
		W408	METAL BOX

**3/8" DRIVE 6 PT. DEEP METRIC SOCKET SET**



SET NO. 355 - 14 PIECES

STOCK NO.	DESCRIPTION	STOCK NO.	DESCRIPTION
WT355	6 PT. DEEP METRIC SOCKETS		
3506MM	6MM	3514MM	14MM
3507MM	7MM	3515MM	15MM
3508MM	8MM	3516MM	16MM
3509MM	9MM	3517MM	17MM
3510MM	10MM	3518MM	18MM
3511MM	11MM	3519MM	19MM
3512MM	12MM	W110	RAIL
3513	13MM	W3	14 CLIPS

**3/8" DRIVE 6 PT. STD & 6 PT. DEEP SOCKET SET**

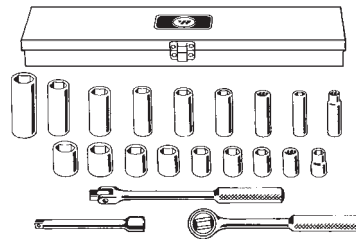

SET NO. 337 - 21 PIECES

STOCK NO.	DESCRIPTION	STOCK NO.	DESCRIPTION
WT337	6 PT. STD. SOCKETS		6 PT. DEEP SOCKETS
3012	3/8	3512	3/8
3014	7/16	3514	7/16
3016	1/2	3516	1/2
3018	9/16	3518	9/16
3020	5/8	3520	5/8
3022	11/16	3522	11/16
3024	3/4	3524	3/4
3026	13/16	3526	13/16
3028	7/8	3528	7/8
		3426	RATCHET
		3405	5" EXTENSION
		3435	FLEX HANDLE
		W416	METAL BOX

**3/8" DRIVE 6 PT. STD. & 6 PT. DEEP SOCKET SETS**

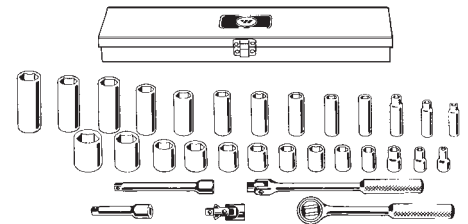

SET NO. 339 - 26 PIECES

STOCK NO.	DESCRIPTION	STOCK NO.	DESCRIPTION
339	6 PT. STD. SOCKETS		6 PT. DEEP SOCKETS
3008	1/4	3508	1/4
3010	5/16	3510	5/16
3012	3/8	3512	3/8
3014	7/16	3514	7/16
3016	1/2	3516	1/2
3018	9/16	3518	9/16
3020	5/8	3520	5/8
3022	11/16	3522	11/16
3024	3/4	3524	3/4
3026	13/16	3526	13/16
3028	7/8	3528	7/8
3030	15/16	3530	15/16
3032	1"	3532	1"
		3426	RATCHET
		3403	3" EXTENSION
		3405	5" EXTENSION
		3435	FLEX HANDLE
		3475	UNIVERSAL
		98	METAL BOX

**YOUR COMPLETE SOURCE FOR INDUSTRIAL SUPPLIES**



**3/8" DRIVE SOCKETS,  
HANDLES & ATTACHMENTS**



**3/8" DRIVE 6 PT. DEEP IMPACT  
SOCKET SET W/ METAL TRAY**



**SET NO. 314 - 8 PIECES**

STOCK NO.	DESCRIPTION
<b>WT314</b>	6 PT. DEEP IMPACT SOCKETS INCLUDES:
3910	5/16
3912	3/8
3914	7/16
3916	1/2
3918	9/16
3920	5/8
3922	11/16
3924	3/4
W008	RAIL
W3	8 CLIPS

**3/8" DRIVE 12 PT.  
FLEX SOCKET SET**



**SET NO. 308 - 7 PIECES**

STOCK NO.	DESCRIPTION
<b>WT308</b>	12 PT. FLEX SOCKETS INCLUDES:
3712	3/8
3714	7/16
3716	1/2
3718	9/16
3720	5/8
3722	11/16
3724	3/4
W008	RAIL
W3	7 CLIPS

**ADAPTERS**

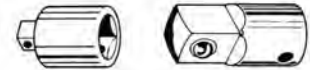

PERMITS INTERCHANGE OF HANDLES, SOCKETS, AND DRIVE TOOLS FROM ONE SIZE TO ANOTHER. NOT REPLACED IF SQUARE ENDS ARE TWISTED OFF.

STOCK NO.	DESCRIPTION	STOCK NO.	DESCRIPTION
<b>WT3452</b>	3/8" F x 1/4" M	<b>WT3454</b>	3/8" F x 1/2" M

**EXTENSIONS**

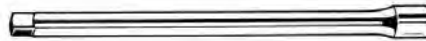

STOCK NO.	DESCRIPTION	STOCK NO.	DESCRIPTION
<b>WT3402</b>	1-1/2"	<b>WT3408</b>	8"
<b>WT3403</b>	3"	<b>WT3412</b>	12"
<b>WT3405</b>	5"	<b>WT3424</b>	24"
<b>WT3411</b>	6" WOBBLE		

**UNIVERSAL**



BUILT IN SPRING TENSION FOR EASY APPLICATION TO THE NUT. NO BINDING OR LOCKED JOINTS. NO SHARP CORNERS.

STOCK NO.	DESCRIPTION
<b>WT3475</b>	UNIVERSAL

**RATCHETS**

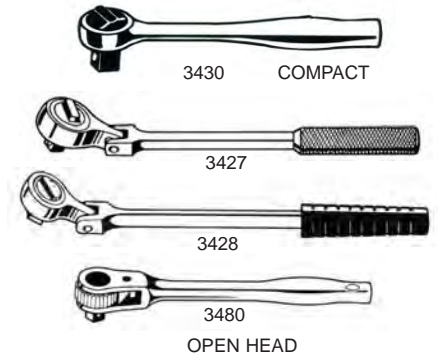

**NO MATTER  
WHAT THE  
JOB IS, WE  
HAVE THE  
WRIGHT TOOL  
FOR YOU**

STOCK NO.	SERIES	DESCRIPTION	LENGTH OVERALL	SWING ARC	NO. OF TEETH	HEAD DIAMETER	RENEWAL KIT NO.
<b>WT3400</b>	400	NITRILE HANDLE	7-1/32	1-1/4	41	1-1/4	<b>WT3491</b>
<b>WT3426</b>	400	STEEL HANDLE	7"	1-1/4	41	1-1/4	<b>WT3491</b>
<b>WT3427</b>	400	FLEX. STEEL HANDLE	9-11/16	1-1/2	41	1-1/4	<b>WT3491</b>
<b>WT3428</b>	400	FLEX. NITRILE HANDLE	10-3/4	1-3/4	41	1-1/4	<b>WT3491</b>
<b>WT3480</b>	80	OPEN HEAD	7-7/8	2-1/4	30	1-1/8	3481
<b>WT3425</b>	400	STEEL HANDLE	11"	1-3/4	41	1-1/4	<b>WT3491</b>
3430	400	COMPACT RATCHET	4-3/4	3/4	45	27/32	3432





**1/2" DRIVE SOCKETS**



**1/2" DRIVE IMPACT SOCKETS  
6 PT. STANDARD  
SAE**

STOCK NO.	SIZE OPENING
WT4812	3/8
WT4814	7/16
WT4816	1/2
WT4818	9/16
WT4820	5/8
WT4822	11/16
WT4824	3/4
WT4826	13/16
WT4828	7/8
WT4830	15/16
WT4832	1"
WT4834	1-1/16
WT4836	1-1/8
WT4840	1-1/4
WT4842	1-5/16
WT4844	1-3/8
WT4846	1-7/16
WT4848	1-1/2



**1/2" DRIVE IMPACT SOCKETS  
6 PT. DEEP  
SAE**

STOCK NO.	SIZE OPENING
WT4912	3/8
WT4914	7/16
WT4916	1/2
WT4918	9/16
WT4920	5/8
WT4922	11/16
WT4924	3/4
WT4926	13/16
WT4928	7/8
WT4930	15/16
WT4932	1"
WT4934	1-1/16
WT4936	1-1/8
WT4940	1-1/4
WT4942	1-5/16
WT4944	1-3/8
WT4946	1-7/16
WT4948	1-1/2



**1/2" DRIVE IMPACT SOCKET  
6 PT. METRIC**

STOCK NO.	SIZE OPENING
WT4810MM	10MM
4811MM	11MM
WT4812MM	12MM
WT4813MM	13MM
WT4814MM	14MM
WT4815MM	15MM
WT4816MM	16MM
WT4817MM	17MM
WT4818MM	18MM
WT4819MM	19MM
WT4820MM	20MM
WT4821MM	21MM
WT4822MM	22MM
WT4823MM	23MM
WT4824MM	24MM
4926MM	26MM
WT4827MM	27MM
4928MM	28MM
WT4830MM	30MM
WT4832MM	32MM
4934MM	34MM
WT4836MM	36MM

**1/2" DRIVE IMPACT SOCKET  
6 PT. DEEP  
METRIC**

STOCK NO.	SIZE OPENING
4910MM	10MM
4911MM	11MM
WT4912MM	12MM
4913MM	13MM
4914MM	14MM
4915MM	15MM
4916MM	16MM
4917MM	17MM
4918MM	18MM
4919MM	19MM
4920MM	20MM
4921MM	21MM
4922MM	22MM
4923MM	23MM
4924MM	24MM
4927MM	27MM
4930MM	30MM
4932MM	32MM
4934MM	34MM

**IF YOU  
DON'T SEE  
SOMETHING  
HERE  
YOU NEED,  
GIVE US A CALL.  
WE WILL  
DO OUR  
BEST  
TO FIND  
IT  
FOR YOU.**

**\*QUALITY PRODUCTS\*  
\*FAIR & COMPETITIVE PRICES\*  
\*EXCELLENT SERVICE\***

**YOU CAN DEPEND ON US!**

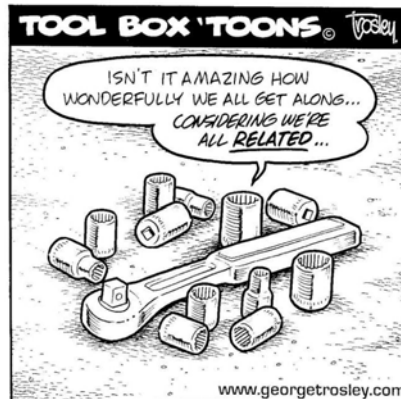



**1/2" DRIVE SOCKETS  
CHROME**



**1/2" DRIVE CHROME SOCKETS  
STANDARD  
SAE**



STOCK NO. 6 PT.	12 PT.	SIZE OPENING
4012	WT4112	3/8
4014	WT4114	7/16
WT4016	WT4116	1/2
4018	WT4118	9/16
4020	WT4120	5/8
4022	WT4122	11/16
WT4024	WT4124	3/4
4026	WT4126	13/16
4028	WT4128	7/8
4030	WT4130	15/16
4032	WT4132	1"
4034	WT4134	1-1/16
4036	WT4136	1-1/8
4038	WT4138	1-3/16
4040	WT4140	1-1/4
4042	WT4142	1-5/16
4044	WT4144	1-3/8
4046	WT4146	1-7/16
4048	WT4148	1-1/2

**STANDARD  
METRIC**

STOCK NO. 12 PT.	SIZE OPENING
4109MM	9MM
WT4110MM	10MM
WT4111MM	11MM
4112MM	12MM
WT4113MM	13MM
4114MM	14MM
WT4115MM	15MM
4116MM	16MM
WT4117MM	17MM
WT4118MM	18MM
WT4119MM	19MM
WT4120MM	20MM
WT4121MM	21MM
WT4122MM	22MM
WT4124MM	24MM
4126MM	26MM
WT4127MM	27MM
WT4130MM	30MM
WT3132MM	32MM

**ADDITIONAL SIZES AVAILABLE  
UPON REQUEST**

**1/2" DRIVE CHROME SOCKETS  
ALLEN  
SAE**

STOCK NO.	SIZE OPENING
WT4208	1/4
WT4210	5/16
WT4212*	3/8
WT4214	7/16
WT4216	1/2
WT4218	9/16
WT4220	5/8



\*HEAVY-DUTY MODEL ALSO AVAILABLE:  
STOCK NO. APEXSZ24

**ALLEN  
METRIC**

STOCK NO.	SIZE OPENING
4208MM	8MM
WT4210MM	10MM
WT4212MM	12MM
WT4214MM	14MM
WT4217MM	17MM

**1/2" DRIVE CHROME SOCKETS  
8 PT. STANDARD  
SAE**

STOCK NO.	SIZE OPENING
WT4312	3/8
WT4314	7/16
WT4316	1/2
WT4318	9/16
WT4320	5/8
WT4322	11/16
WT4324	3/4
4326	13/16
4328	7/8
4330	15/16
4332	1"
4334	1-1/16
4336	1-1/8
4338	1-3/16
4340	1-1/4



**1/2" DRIVE CHROME SOCKETS  
SPARK PLUGS  
SAE**

STOCK NO.	SIZE OPENING
4590	5/8
WT4596	13/16
4598	7/8



**1/2" DRIVE CHROME SOCKETS  
DEEP  
SAE**



STOCK NO. 6 PT.	12 PT.	SIZE OPENING
4512	4612	3/8
WT4514	4614	7/16
4516	WT4616	1/2
4518	WT4618	9/16
4520	WT4620	5/8
4522	WT4622	11/16
4524	WT4624	3/4
4526	WT4626	13/16
4528	WT4628	7/8
4530	WT4630	15/16
4532	WR4632	1"
4534	WT4634	1-1/16
4536	WT4636	1-1/8
4538	4638	1-3/16
WT4540	4640	1-1/4
	4648	1-1/2



**CALL US FOR ALL YOUR NEEDS  
855-785-TOOL**



**1/2" DRIVE SOCKET SETS**



**1/2" DRIVE 12 PT. STD. SOCKET SET**



STOCK NO.	DESCRIPTION
<b>SET NO. WT416</b>	<b>12 PT. STD. SOCKETS- 14 PIECES INCLUDES</b>
4114	7/16
4116	1/2
4118	9/16
4120	5/8
4122	11/16
4124	3/4
4126	13/16
4128	7/8
4130	15/16
4132	1"
4134	1-1/16
4136	1-1/8
4138	1-3/16
4140	1-1/4
2-W010	RAILS
W4	14 CLIPS

**1/2" DRIVE 6 PT. DEEP SOCKET SET**



STOCK NO.	DESCRIPTION
<b>SET NO. 410</b>	<b>6 PT. DEEP SOCKETS 8 PIECES- INCLUDES</b>
4516	1/2
4518	9/16
4520	5/8
4522	11/16
4524	3/4
4526	13/16
4528	7/8
4530	15/16
W010	RAIL
W4	8 CLIPS

**1/2" DRIVE 12 PT. STD. METRIC SET**



STOCK NO.	DESCRIPTION
<b>SET NO. WT469</b>	<b>12 PT. STD. METRIC SOCKETS - 18 PIECES INCLUDES</b>
4112MM	12MM
4113MM	13MM
4114MM	14MM
4115MM	15MM
4116MM	16MM
4117MM	17MM
4118MM	18MM
4119MM	19MM
4120MM	20MM
4121MM	21MM
4122MM	22MM
4123MM	23MM
4124MM	24MM
4125MM	25MM
4126MM	26MM
4127MM	27MM
4130MM	30MM
4132MM	32MM
2-W110	RAILS
W4	18 CLIPS

**1/2" DRIVE 6 PT. STD. SOCKET SET**



STOCK NO.	DESCRIPTION
<b>SET NO. 419</b>	<b>6 PT. STD. SOCKETS 14 PIECES - INCLUDES</b>
4014	7/16
4016	1/2
4018	9/16
4020	5/8
4022	11/16
4024	3/4
4026	13/16
4028	7/8
4030	15/16
4032	1"
4034	1-1/16
4036	1-1/8
4038	1-3/16
4040	1-1/4
2-W010	RAILS
W4	14 CLIPS

**1/2" DRIVE 6 PT. STD. IMPACT SOCKET SET**



STOCK NO.	DESCRIPTION
<b>SET NO. WT415</b>	<b>6 PT. STD. IMPACT SOCKETS - 13 PIECES INCLUDES</b>
4814	7/18
4816	1/2
4818	9/16
4820	5/8
4822	11/16
4824	3/4
4826	13/16
4828	7/8
4830	15/16
4832	1"
4834	1-1/16
4836	1-1/8
4840	1-1/4
2-W010	RAILS
W4	13 CLIPS

**1/2" DRIVE 6 PT. DEEP IMPACT SOCKET SET**



STOCK NO.	DESCRIPTION
<b>SET NO. WT412</b>	<b>6 PT. DEEP IMPACT SOCKETS - 11 PIECES INCLUDES</b>
4912	3/8
4914	7/16
4916	1/2
4918	9/16
4920	5/8
4922	11/16
4924	3/4
4926	13/16
4928	7/8
4930	15/16
4932	1"
W013	RAIL
W4	11 CLIPS

**1/2" DRIVE 12 PT. DEEP SOCKET SET**



STOCK NO.	DESCRIPTION
<b>SET NO. WT409</b>	<b>12 PT. DEEP SOCKETS 8 PIECES - INCLUDES</b>
4616	1/2
4618	9/16
4620	5/8
4622	11/16
4624	3/4
4626	13/16
4628	7/8
4630	15/16
W010	RAIL
W4	8 CLIPS

**OUR COURTEOUS AND  
KNOWLEDGEABLE STAFF  
IS READY TO TAKE CARE  
OF YOUR ORDER**

THE ONLY WAY TO HAVE A FRIEND IS TO BE ONE.  
--RALPH WALDO EMERSON



**WRIGHT TOOL**

**1/2" DRIVE SOCKET SETS & ACCESSORIES**



**WRIGHT TOOL**

**1/2 DRIVE 12 PT. STD. SOCKET SET**

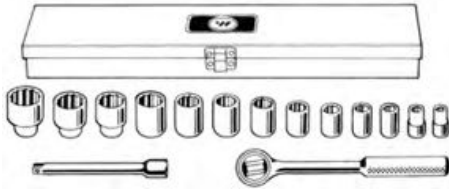

STOCK NO.	DESCRIPTION
<b>SET NO. WT417</b>	12 PT. STD. SOCKETS 15 PIECES - INCLUDES
4114	7/16
4116	1/2
4118	9/16
4120	5/8
4122	11/16
4124	3/4
4126	13/16
4128	7/8
4130	15/16
4132	1"
4134	1-1/16
4136	1-1/8
4140	1-1/4
4426	RATCHET
4405	5" EXTENSION
W411	METAL BOX

**1/2" DRIVE 6 PT. DEEP METRIC IMPACT SOCKET SET**



STOCK NO.	DESCRIPTION
<b>SET NO. WT467</b>	6 PT. DEEP IMPACT SOCKETS - 16 PIECES INCLUDES
4910MM	10MM
4911MM	11MM
4912MM	12MM
4913MM	13MM
4914MM	14MM
4915MM	15MM
4916MM	16MM
4917MM	17MM
4918MM	18MM
4919MM	19MM
4920MM	20MM
4921MM	21MM
4922MM	22MM
4923MM	23MM
4924MM	24MM
4927MM	27MM
2-W110	RAILS
W4	16 CLIPS

**1/2" DRIVE 6 PT. STD. METRIC IMPACT SOCKET SET**



STOCK NO.	DESCRIPTION
<b>SET NO. WT466</b>	6 PT. STD. METRIC IMPACT SOCKETS - 16 PIECES INCLUDES
4810MM	10MM
4811MM	11MM
4812MM	12MM
4813MM	13MM
4814MM	14MM
4815MM	15MM
4816MM	16MM
4817MM	17MM
4818MM	18MM
4819MM	19MM
4820MM	20MM
4821MM	21MM
4822MM	22MM
4823MM	23MM
4824MM	24MM
4827MM	27MM
2-W110	RAILS
W4	16 CLIPS

**EXTENSIONS**



STOCK NO.	DESCRIPTION	STOCK NO.	DESCRIPTION
WT4402	2"	WT4410	10"
WT4405	5"	4420	20"

**IMPACT EXTENSION**



STOCK NO.	DESCRIPTION
WT4905	5"
4909	10"

**ADAPTER**



FOR INTERCHANGES OF SOCKETS AND ATTACHMENTS FROM ONE DRIVE SIZE TO ANOTHER.

STOCK NO.	DESCRIPTION
WT4453	1/2" F x 3/8" M

**IMPACT ADAPTER**



STOCK NO.	DESCRIPTION
4900	1/2 F x 3/8 M (BALL LOCK)
WT4902	1/2 F x 3/4 M (BALL LOCK)

**UNIVERSAL**



BUILT IN SPRING TENSION FOR EASY APPLICATION TO NUT. NO BINDING OR LOCKED JOINTS. NO SHARP CORNERS.

STOCK NO.	DESCRIPTION
WT4475	UNIVERSAL

**IMPACT UNIVERSAL JOINT**



STOCK NO.	DESCRIPTION
WT4800	UNIVERSAL

**1/2" DRIVE REPLACEMENT HEX BIT**



STANDARD STOCK NO.	SIZE	METRIC STOCK NO.	SIZE
4208B	1/4	42M06B	6MM
4210B	5/16	42M08B	8MM
4212B	3/8	42M10B	10MM
4214B	7/16	42M12B	12MM
WT4216B	1/2	42M14B	14MM
4218B	9/16	42M17B	17MM
4220B	5/8		

3/8" REPLACEMENT HEX BIT FOR HEAVY-DUTY APEXSZ24 1/2" DRIVE SOCKET  
**STOCK NO. APEXSZ16A**

TO ERR IS HUMAN; TO ADMIT IT, SUPERHUMAN.  
--DOUG LARSON



**WRIGHT TOOL**

**1/2" DRIVE HANDLES & ATTACHMENTS**



**WRIGHT TOOL**

**RATCHETS**



4400



4425

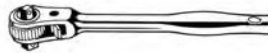

4480



4426

STOCK HEAD NO.	SERIES RENEWAL	DESCRIPTION	LENGTH		HANDLES	NO. OF	
			OVERALL	SWING ARC			TEETH
WT4400	400	NITRILE HANDLE	10-1/2	1-1/4	45	1-5/8	WT4491
WT4425	400	STEEL HANDLE XL	15"	2"	45	1-5/8	WT4491
WT4426	400	STEEL HANDLE	10-1/4	1-1/4	45	1-5/8	WT4491
WT4480	80	OPEN HEAD	10-1/2	3-1/4	30	1-5/16	WT4481

**RENEWAL KITS "400" SERIES**



ONE PIECE, FOOLPROOF. JUST DROP INTO PLACE. EXTENDS LIFE OF RATCHET. ON-THE-SPOT PURCHASE ELIMINATES WAITING FOR REPAIR.

STOCK NO.	DESCRIPTION
WT4491	FOR ALL 400 SERIES RATCHETS
WT4481	FOR ALL 4480 RATCHETS

**FLEX HANDLES**

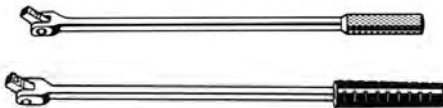

18" LONG. PARTS ARE CHROME PLATED BEFORE ASSEMBLY TO ELIMINATE RUST FORMATION BETWEEN FORK AND SQUARE. STEEL PIN AND TENSION WASHER CONSTRUCTION FOR EXTRA STRENGTH. NO BINDING OR LOCKED JOINTS.

STOCK NO.	DESCRIPTION
WT4435	18" FLEX-KNURLED STEEL HANDLE
WT4438	18" FLEX-NITRILE HANDLE

**SLIDING T**

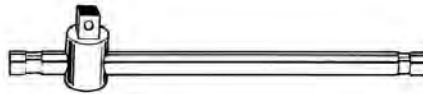

HEAD HELD IN PLACE WITH FRICTION BALL SO IT CAN SLIDE TO ENDS OF BAR WITH NO OVERHANG. WORKS IN TIGHTER PLACES.

STOCK NO.	DESCRIPTION
WT4443	10-11/16"

**SPEEDER**

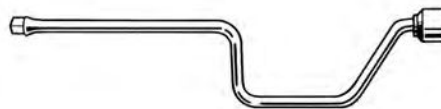

DESIGNED FOR ONE HAND OPERATION. HEAD FITS IN PALM OF HAND WHILE THUMB SPINS SHAFT.

STOCK NO.	DESCRIPTION
WT4445	16-3/4"

**1/2" DRIVE HEAVY-DUTY SCREWDRIVER SOCKET**



STOCK NO. PROTO5444A

CONSULT  
OUR  
DETAILED  
CATALOG INDEX  
FOR  
EASY REFERENCE





**3/4" DRIVE SOCKETS**



**3/4" DRIVE 6 PT. CHROME DEEP SOCKETS**



STOCK NO.	SIZE
WT6524	3/4
WT6526	13/16
WT6528	7/8
WT6530	15/16
WT6532	1"
WT6534	1-1/16
WT6536	1-1/8
WT6538	1-3/16
WT6540	1-1/4
WT6542	1-5/16
WT6544	1-3/8
WT6546	1-7/16
WT6548	1-1/2
WT6552	1-5/8

**3/4" DRIVE 6 PT. DEEP IMPACT SOCKET SET**



STOCK NO.	DESCRIPTION
SET NO. 608	6 PT. DEEP IMPACT SOCKETS 8 PIECES - INCLUDES
6928	7/8
6930	15/16
6932	1"
6934	1-1/16
6936	1-1/8
6940	1-1/4
6942	1-5/16
6948	1-1/2
CARDBOARD CARTON	

**3/4" DRIVE IMPACT SOCKETS**



ALLEN W/BITS	STANDARD 6 PT.	SAE DEEP 6 PT.	SIZE OPENING
WT6224	WT6824	WT6924	3/4
	WT6826	WT6926	13/16
WT6228	WT6828	WT6928	7/8
	WT6830	WT6930	15/16
WT6232	WT6832	WT6932	1"
	WT6834	WT6934	1-1/16
	WT6836	WT6936	1-1/8
	WT6838	WT6938	1-3/16
	WT6840	WT6940	1-1/4
	WY6842	WT6942	1-5/16
	WT6844	WT6944	1-3/8
	WT6846	WT6946	1-7/16
	WT6848	WT6948	1-1/2
	WT6850	WT6950	1-9/16
	WT6852	WT6952	1-5/8
	WT6854	WT6954	1-11/16
	WT6856	WT6956	1-3/4
	WT6858	WT6958	1-13/16
	WT6860	WT6960	1-7/8
	WT6862	WT6962	1-15/16
	WT6864	WT6964	2"
	WT6890	6966	2-1/16
	WT6892	WT6968	2-1/8
	WT6894	69100	2-3/16
	WT6896	69102	2-1/4
	WT6898	69106	2-3/8

**3/4" DRIVE 12 PT. CHROME SOCKETS**



12 PT. STD.	SAE SIZE OPENING	12 PT. STD.	METRIC SIZE OPENING
WT6124	3/4	6119MM	19MM
WT6126	13/14	6122MM	22MM
WT6128	7/8	6124MM	24MM
WT6130	15/16	6127MM	27MM
WT6132	1"	6130MM	30MM
WT6134	1-1/16	6132MM	32MM
WT6136	1-1/8	6136MM	36MM
WT6138	1-3/16	6138MM	38MM
WT6140	1-1/4	6141MM	41MM
WT6142	1-5/16	6146MM	46MM
WT6144	1-3/8	6150MM	50MM
WT6146	1-7/16	6154MM	54MM
WT6148	1-1/2	6155MM	55MM
WT6150	1-9/16	6158MM	58MM
WT6152	1-5/8	6160MM	60MM
WT6154	1-11/16		
WT6156	1-3/4		
WT6158	1-13/16		
WT6160	1-7/8		
WT6164	2"		
WT6166	2-1/16		
WT6168	2-1/8		
WT6170	2-3/16		
WT6172	2-1/4		
WT6176	2-3/8		

**3/4" DRIVE 6 PT. STD. IMPACT SOCKET SET**



STOCK NO.	DESCRIPTION
SET NO. 609	6 PT. STD. IMPACT SOCKETS 9 PIECES - INCLUDES
6824	3/4
6826	13/16
6828	7/8
6830	15/16
6832	1"
6834	1-1/16
6836	1-1/8
6838	1-3/16
6840	1-1/4
CARDBOARD CARTON	

**3/4" DRIVE 6 PT. METRIC IMPACT SOCKETS**



STOCK NO.	SIZE
WT6824MM	24MM
WT6827MM	27MM
WT6830MM	30MM
WT6832MM	32MM
WT6836MM	36MM
WT6838MM	38MM
WT6842MM	42MM
WT6846MM	46MM
WT6850MM	50MM

**WE HAVE OVER 30,000 INVENTORY ITEMS. WE ARE CONSTANTLY ADDING TO OUR INVENTORY TO ACCOMMODATE OUR CUSTOMERS' NEEDS.**

**IF THERE IS AN ITEM YOU CAN'T FIND, GIVE US A CALL. IT'S OUR JOB TO FIND IT FOR YOU.**

A MAN WAS WALKING DOWN A COUNTRY ROAD WHEN HE HEARD A VOICE COMING FROM BEHIND A TREE, BUT ALL HE COULD SEE WAS A HORSE.

"HELLO, REMEMBER ME?" THE VOICE SAID. "I WON THE KENTUCKY DERBY TWO YEARS AGO."

"A TALKING HORSE!" THE MAN EXCLAIMED, SO HE RUSHED TO A NEARBY FIELD WHERE THE FARMER WAS WORKING AND ASKED, "WHAT WOULD YOU TAKE FOR THE HORSE?"

"THAT DARNED HORSE IS NO GOOD, YOU CAN HAVE HIM FOR 20 DOLLARS."

"TWENTY DOLLARS! I'LL GIVE YOU 2,000."

"HAS THAT OLD HAYBAG BEEN GIVING YOU THAT BALONEY ABOUT WINNING THE KENTUCKY DERBY? LISTEN, I HAPPEN TO KNOW HE CAME IN LAST."



**WRIGHT TOOL**

**3/4" DRIVE HANDLES & ATTACHMENTS**



**WRIGHT TOOL**

**3/4" DRIVE 12 PT. STD. SOCKET SET**

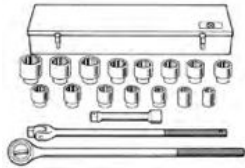

STOCK NO.	DESCRIPTION	STOCK NO.	DESCRIPTION
SET NO. 618	12 PT. STD. SOCKETS 19 PIECES- INCLUDES		
6128	7/8	6152	1-5/8
6130	15/16	6154	1-11/16
6134	1-1/16	6156	1-3/4
6136	1-1/8	6158	1-13/16
6140	1-1/4	6160	1-7/8
6142	1-5/16	6164	2"
6144	1-3/8	6400	RATCHET
6146	1-7/16	6408	8" EXTENSION
6148	1-1/2	6435	FLEX HANDLE
237	METAL BOX		

**3/4" DRIVE 12 PT. STD. SOCKET SET**



STOCK NO.	DESCRIPTION	STOCK NO.	DESCRIPTION
SET NO. 631	12 PT. STD. SOCKETS		31 PIECES INCLUDES:
6128	7/8	6160	1-7/8
6130	15/16	6164	2"
6132	1"	6166	2-1/16
6134	1-1/16	6168	2-1/8
6136	1-1/8	6170	2-3/16
6138	1-3/16	6172	2-1/4
6140	1-1/4	6176	2-3/8
6142	1-5/16	6400	RATCHET
6144	1-3/8	6403	3-1/2" EXT.
6146	1-7/16	6408	8" EXT.
6148	1-1/2	6416	16" EXT.
6150	1-9/16	6435	FLEX HANDLE
6152	1-5/8	6440	BULL BAR
6154	1-11/16	6443	SLIDING T
6156	1-3/4	6475	UNIVERSAL
6158	1-13/16	237	METAL BOX

**UNIVERSAL**



STEEL PIN AND TENSION WASHER CONSTRUCTION FOR ADDED STRENGTH. NO BINDING OR LOCKED JOINT.

STOCK NO.	DESCRIPTION
WT6475	UNIVERSAL

**IMPACT UNIVERSAL**



STOCK NO. WT6800

**IMPACT ADAPTER**



STOCK NO.	DESCRIPTION
WT6900	3/4" F x 1/2" M
WT6901	3/4" F x 1" M

**IMPACT EXTENSIONS**



STOCK NO.	DESCRIPTION
WT6907	7"
6910	10"
6913	13"

**EXTENSIONS**

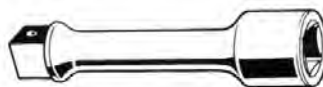

STOCK NO.	DESCRIPTION
WT6403	3-1/2"
WT6408	8"
WT6416	16"

**RATCHET**



45 TOOTH, ENCLOSED MECHANISM, 24" LENGTH OVERALL. REQUIRES ONLY 4-7/8" ARC AT END OF HANDLE TO GET NEXT BITE.

STOCK NO.	DESCRIPTION
WT6400	24"

**RENEWAL KIT**



STOCK NO.	DESCRIPTION
WT6402	45 TOOTH, 6400 RATCHET

**BULL BAR**



2 POSITION HEAD-KNURLED GRIP. 24" LENGTH. EXTRA STRENGTH FOR HEAVY-DUTY APPLICATIONS.

STOCK NO.	DESCRIPTION
WT6440	24"
6441	REPAIR KIT

**SLIDING T**

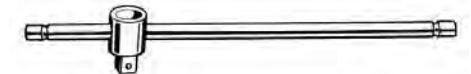

HEAD HELD IN PLACE BY FRICTION BALL SO IT CAN SLIDE TO ENDS OF BAR WITH NO OVERHANG. WORKS IN TIGHTER PLACES.

STOCK NO.	DESCRIPTION
WT6443	17-1/2"

**FLEX HANDLE**



STEEL PIN AND TENSION WASHER CONSTRUCTION FOR ADDED STRENGTH. CHROME PLATED BEFORE ASSEMBLY TO ELIMINATE RUST FORMATION BETWEEN FORK AND SQUARE. NO BINDING OR LOCKED JOINT.

STOCK NO.	DESCRIPTION
WT6435	22"



**1" DRIVE SOCKETS,  
HANDLES & ATTACHMENTS**



**1" DRIVE CHROME SOCKETS**



STD. 12 PT.	SIZE OPENING	STD. 12 PT.	SIZE OPENING
8146	1-7/16	8176	2-3/8
<b>WT8148</b>	1-1/2	8178	2-7/16
8152	1-5/8	8180	2-1/2
8154	1-11/16	8182	2-9/16
8156	1-3/4	8184	2-5/8
8158	1-13/16	8188	2-3/4
8160	1-7/8	8190	2-13/16
8162	1-15/16	8194	2-15/16
<b>WT8164</b>	2"	8196	3"
8166	2-1/16	8197	3-1/8
<b>WT8168</b>	2-1/8	8198	3-3/8
<b>WT8170</b>	2-3/16	8199	3-1/2
<b>WT8172</b>	2-1/4		
<b>WT8174</b>	2-5/16		

**1" DRIVE IMPACT SOCKETS**



STOCK NO. STD. 6 PT.	SIZE OPENING	STOCK NO. STD. 6 PT.	SIZE OPENING
8824	3/4	<b>WT8872</b>	2-1/4
8826	13/16	8874	2-5/16
8828	7/8	<b>WT8876</b>	2-3/8
8830	15/16	8878	2-7/16
<b>WT8832</b>	1"	<b>WT8880</b>	2-1/2
<b>WT8834</b>	1-1/16	8882	2-9/16
<b>WT8836</b>	1-1/8	<b>WT8884</b>	2-5/8
<b>WT8838</b>	1-3/16	8886	2-11/16
<b>WT8840</b>	1-1/4	<b>WT8888</b>	2-3/4
<b>WT8842</b>	1-5/16	8890	2-13/16
8844	1-3/8	8892	2-7/8
<b>WT8846</b>	1-7/16	8894	2-15/16
<b>WT8848</b>	1-1/2	<b>WT8896</b>	3"
8850	1-9/16	<b>WT8897</b>	3-1/8
<b>WT8852</b>	1-5/8	<b>WT8897A</b>	3-1/4
8854	1-11/16	8898	3-3/8
8856	1-3/4	<b>WT8899</b>	3-1/2
<b>WT8858</b>	1-13/16	88116	3-5/8
8860	1-7/8	88120	3-3/4
8862	1-15/16	88124	3-7/8
<b>WT8864</b>	2"	88128	4"
<b>WT8866</b>	2-1/16	88132	4-1/8
<b>WT8868</b>	2-1/8	88136	4-1/4
<b>WT8870</b>	2-3/16	88144	4-1/2

QUESTIONS ABOUT YOUR ORDER?  
WE'RE HERE TO HELP!!

**1" DRIVE 6 PT. DEEP  
IMPACT SOCKETS**



STOCK NO.	NOM. SIZE	STOCK NO.	NOM. SIZE
<b>WT8924</b>	3/4	<b>WT8970</b>	2-3/16
8926	13/16	<b>WT8972</b>	2-1/4
8928	7/8	8974	2-5/16
<b>WT8930</b>	15/16	8976	2-3/8
<b>WT8932</b>	1"	8980	2-1/2
<b>WT8933</b>	1-1/16	8981	2-9/16
<b>WT8936</b>	1-1/8	8988	2-3/4
<b>WT8938</b>	1-3/16	8990	2-13/16
<b>WT8939</b>	1-1/4	8992	2-7/8
<b>WT8942</b>	1-5/16	8994	2-15/16
<b>WT8944</b>	1-3/8	8996	3"
8946	1-7/16	89100	3-1/8
<b>WT8948</b>	1-1/2	89104	3-1/4
8950	1-9/16	89108	3-3/8
<b>WT8952</b>	1-5/8	89112	3-1/2
8954	1-11/16	89116	3-5/8
<b>WT8956</b>	1-3/4	89120	3-3/4
<b>WT8958</b>	1-13/16	89124	3-7/8
<b>WT8960</b>	1-7/8	89128	4"
8962	1-15/16	89132	4-1/8
<b>WT8964</b>	2"	89136	4-1/4
<b>WT8966</b>	2-1/16	89144	4-1/2
<b>WT8968</b>	2-1/8		

**RATCHET**



45 TOOTH, ENCLOSED MECHANISM. REQUIRES ONLY 4-7/8" ARCH AT END OF HANDLE TO GET THE NEXT BITE. EXTRA STRONG FOR HEAVIEST DUTY JOBS.

STOCK NO.	DESCRIPTION
<b>WT8400</b>	30"

**RENEWAL KIT**



STOCK NO.	DESCRIPTION
<b>WT8402</b>	45 TOOTH, 8400 RATCHET

**EXTENSIONS**



STOCK NO.	DESCRIPTION
<b>WT8408</b>	8"
8417	17"

**IMPACT ADAPTER**



STOCK NO.	DESCRIPTION
<b>WT8900</b>	1" F x 3/4" M

**FLEX HANDLE**



STEEL PIN AND TENSION WASHER CONSTRUCTION FOR ADDED STRENGTH. CHROME PLATED BEFORE ASSEMBLY TO ELIMINATE RUST FORMATION BETWEEN THE FORK AND SQUARE. NO BINDING OR LOCKED JOINT.

STOCK NO.	DESCRIPTION
8435	26"

**BULL BAR**



2 POSITION HEAD-KNURLED GRIP. 30" LENGTH. EXTRA STRENGTH FOR HEAVY-DUTY APPLICATIONS.

STOCK NO.	DESCRIPTION
<b>WT8440</b>	30"

**SLIDING T**



HEAD HELD IN PLACE BY FRICTION BALL SO IT CAN SLIDE TO ENDS OF BAR WITH NO OVERHANG. WORKS IN TIGHTER PLACES.

STOCK NO.	DESCRIPTION
8443	22"

**IMPACT EXTENSION**



STOCK NO.	DESCRIPTION
8907	7"





**IMPACT SOCKET SETS**



**GREY PNEUMATIC IMPACT SOCKETS ARE DESIGNED FOR PROFESSIONAL TOOL USERS. THEY ARE ENGINEERED SPECIFICALLY FOR USE WITH IMPACT TOOLS, USING THE MOST UP TO DATE INDUSTRIAL SPECIFICATIONS.**

**3/4" DRIVE IMPACT HEX DRIVE METRIC SET**



SET NO. GP8196MH - 6 PIECES

STOCK NO.	DESCRIPTION	STOCK NO.	DESCRIPTION
GP8196MH			
3912M	12MM	3919M	19MM
3914M	14MM	3922M	22MM
3917M	17MM	3924M	24MM
B8196MC	MOLDED CASE		

**3/4" DRIVE IMPACT HEX DRIVE STANDARD LENGTH METRIC SET**



SET NO. 8026M - 26 PIECES

STOCK NO.	DESCRIPTION	STOCK NO.	DESCRIPTION
8026M			
3019M	19MM	3032M	32MM
3020M	20MM	3033M	33MM
3021M	21MM	3034M	34MM
3022M	22MM	3035M	35MM
3023M	23MM	3036M	36MM
3024M	24MM	3038M	38MM
3025M	25MM	3040M	40MM
3026M	26MM	3041M	41MM
3027M	27MM	3042M	42MM
3028M	28MM	3043M	43MM
3029M	29MM	3044M	44MM
3030M	30MM	3046M	46MM
3031M	31MM	3050M	50MM
	METAL CASE		

**3/4" DRIVE IMPACT HEX DRIVE DEEP METRIC SET**



SET NO. 8026MD - 26 PIECES

STOCK NO.	DESCRIPTION	STOCK NO.	DESCRIPTION
8026MD			
3019MD	19MM	3032MD	32MM
3020MD	20MM	3033MD	33MM
3021MD	21MM	3034MD	34MM
3022MD	22MM	3035MD	35MM
3023MD	23MM	3036MD	36MM
3024MD	24MM	3038MD	38MM
3025MD	25MM	3040MD	40MM
3026MD	26MM	3041MD	41MM
3027MD	27MM	3042MD	42MM
3028MD	28MM	3043MD	43MM
3029MD	29MM	3044MD	44MM
3030MD	30MM	3046MD	46MM
3031MD	31MM	3050MD	50MM
	METAL CASE		

**3/8" DRIVE IMPACT HEX DRIVE SET**



SET NO. GP1297H - 7 PIECES

STOCK NO.	DESCRIPTION	STOCK NO.	DESCRIPTION
GP1297H			
1906F	3/16	1912F	3/8
1907F	7/32	1914F	7/16
1908F	1/4	1916F	1/2
1910F	5/16	BM10	MOLDED CASE

**3/8" DRIVE IMPACT HEX DRIVE METRIC SET**



SET NO. GP1297MH - 7 PIECES

STOCK NO.	DESCRIPTION	STOCK NO.	DESCRIPTION
GP1297MH			
1904M	4MM	1908M	8MM
1905M	5MM	1910M	10MM
1906M	6MM	1912M	12MM
1907M	7MM	BM10	MOLDED CASE

**3/8 DRIVE INTERNAL TORX IMPACT DRIVERS**



SET NO. 1200T - 9 PIECES

STOCK NO.	DESCRIPTION	STOCK NO.	DESCRIPTION
1200T			
1120T	T20	1145T	T45
1125T	T25	1147T	T47
1127T	T27	1150T	T50
1130T	T30	1155T	T55
1140T	T40		METAL CASE

**1/2" DRIVE IMPACT HEX DRIVE SET**



SET NO. GP1398H - 10 PIECES

STOCK NO.	DESCRIPTION	STOCK NO.	DESCRIPTION
GP1398H			
2908F	1/4	2916F	1/2
2909F	9/32	2918F	9/16
2910F	5/16	2920F	5/8
2912F	3/8	2922F	11/16
2914F	7/16	2924F	3/4
	MOLDED CASE		

**1/2" DRIVE IMPACT HEX DRIVE METRIC SET**



SET NO. GP1498MH - 10 PIECES

STOCK NO.	DESCRIPTION	STOCK NO.	DESCRIPTION
GP1498MH			
2906M	6MM	2914M	14MM
2907M	7MM	2915M	15MM
2908M	8MM	2917M	17MM
2910M	10MM	2918M	18MM
2912M	12MM	2919M	19MM
	MOLDED CASE		

**3/4" DRIVE IMPACT HEX DRIVE SET**



SET NO. GP8096H - 6 PIECES

STOCK NO.	DESCRIPTION	STOCK NO.	DESCRIPTION
GP8096H			
3916F	1/2	3924F	3/4
3918F	9/16	3928F	7/8
3920F	5/8	3932F	1"
B8096MC	MOLDED CASE		



**IMPACT SOCKET SETS**



GREY PNEUMATIC IMPACT SOCKETS ARE DESIGNED FOR PROFESSIONAL TOOL USERS. THEY ARE ENGINEERED SPECIFICALLY FOR USE WITH IMPACT TOOLS, USING THE MOST UP TO DATE INDUSTRIAL SPECIFICATIONS.

**1" DRIVE IMPACT HEX DRIVE SET**  
SET NO. GP9096H - 6 PIECES



STOCK NO.	DESCRIPTION	STOCK NO.	DESCRIPTION
GP9096H			
4924F	3/4	4936F	1-1/8
4928F	7/8	4940F	1-1/4
4932F	1"	4944F	1-3/8
B9096MC	MOLDED CASE		

**1" DRIVE IMPACT HEX DRIVE**  
SET NO. GP9196MH - 6 PIECES



STOCK NO.	DESCRIPTION	STOCK NO.	DESCRIPTION
GP9196MH			
4914M	14MM	4922M	22MM
4917M	17MM	4924M	24MM
4919M	19MM	4927M	27MM
B9196MC	MOLDED CASE		

**1" DRIVE IMPACT DRIVE SET**  
STANDARD LENGTH  
SET NO. 9021 - 16 PIECES



STOCK NO.	DESCRIPTION	STOCK NO.	DESCRIPTION
9021			
4066R	2-1/16	4082R	2-9/16
4068R	2-1/8	4084R	2-5/8
4070R	2-3/16	4086R	2-11/16
4072R	2-1/4	4088R	2-3/4
4074R	2-5/16	4090R	2-13/16
4076R	2-3/8	4092R	2-7/8
4078R	2-7/16	4094R	2-15/16
4080R	2-1/2	4096R	3"
	METAL CASE		

**3/8" DRIVE IMPACT HEX DRIVER**



STOCK NO.	SIZE
1906F	3/16
1907F	7/32
1908F	1/4
1910F	5/16
1912F	3/8
1914F	7/16
1916F	1/2

**1/2" DRIVE IMPACT HEX DRIVE**



STOCK NO.	SIZE
GP2908F	1/4
2909F	9/32
GP2910F	5/16
GP2912F	3/8
2914F	7/16
GP2916F	1/2
2918F	9/16
GP2920F	5/8
2922F	11/16
GP2924F	3/4

**1/2" DRIVE IMPACT HEX DRIVE METRIC**



STOCK NO.	SIZE
GP2906M	6MM
2907M	7MM
GP2908M	8MM
GP2910M	10MM
2911M	11MM
GP2912M	12MM
2913M	13MM
GP2914M	14MM
2915M	15MM
2916M	16MM
GP2917M	17MM
2918M	18MM
2919M	19MM

ADDITIONAL ITEMS AVAILABLE UPON REQUEST

NEVER INSULT AN ALLIGATOR UNTIL AFTER YOU HAVE CROSSED THE RIVER.  
--CORDELL HULL



QUALITY PRODUCTS  
FAIR AND COMPETITIVE PRICES  
AND EXCELLENT SERVICE IS OUR REPUTATION.

**TORQUE WRENCHES AND SOCKET ACCESSORIES**

**MICROMETER TYPE TORQUE WRENCHES**



PERMITS PRECISE TIGHTENING OF FASTENERS TO MANUFACTURERS' SPECIFICATIONS. MICROMETER TYPE SCALE ADJUSTED BY ROTATING HAND GRIP. WRENCH INDICATES DESIRED TORQUE BY FEEL AND SOUND. TORQUES CLOCKWISE AND COUNTER-CLOCKWISE. ACCURATE THROUGHOUT ENTIRE TORQUE RANGE +/- 4% CLOCKWISE AND +/- 6% COUNTER-CLOCKWISE. TORQUE WRENCHES ARE CHROME FINISHED.

**RATCHET HEAD MODELS**

**IN.-LB. GRADUATIONS:**

STOCK NO.	DRIVE SIZE	IN.-LB. RANGE	GRADUATIONS	LENGTH
SK74025	3/8	25-250	1 IN.LB.	13.4"

**FT.-LB. GRADUATIONS:**

STOCK NO.	DRIVE SIZE	FT.-LB. RANGE	GRADUATIONS	LENGTH
SK74150	1/2	20-150	1 FT.LB.	20.8"
SK74250	1/2	25-250	1 FT.LB.	20.8"
WT6448	3/4	100-600	5 FT.LB.	42"

*ADDITIONAL SIZES AVAILABLE UPON REQUEST*

**SPANNER WRENCHES**

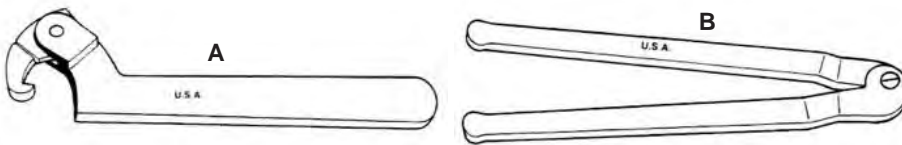

**(A) BLACK ADJUSTABLE SPANNER**

HOOK	SPANNER			WRENCH	
	DIAMETER CAPACITY	THICKNESS HANDLE	THICKNESS HOOK	HOOK DEPTH	O/A LENGTH
WT9630	3/4 TO 2"	1/4	11/32	1/8	6-3/8
WT9631	1-1/4 TO 3"	9/32	13/32	5/32	8-1/8
WT9632	2" TO 4-3/4	5/16	15/32	3/16	11-3/8
WT9633	4-1/2 TO 6 1/4	5/16	15/32	1/4	12-1/8
9634	6-1/8 TO 8-3/4	5/16	15/32	5/16	13-3/4

**(B) BLACK ADJUSTABLE FACE SPANNER WRENCH**

STOCK NO.	MAXIMUM CAPACITY	PIN DIAMETER	O/A LENGTH
WT9636	2"	3/16	6-3/8
WT9637	3"	1/4	8-1/4
WT9638	4"	5/16	10-3/8

**SOCKET HOLDERS**



THESE HANDY DEVICES HOLD SOCKETS AND ATTACHMENTS NEATLY AND ORDERLY FOR MAXIMUM CONVENIENCE AND READY ACCESSIBILITY.

STOCK NO.	DESCRIPTION
CTA9593	SOCKET HOLDER W/SIXTEEN 1/4" CLIPS
CTA9595	SOCKET HOLDER W/ SIXTEEN 3/8" CLIPS
CTA9597	SOCKET HOLDER W/ SIXTEEN 1/2" CLIPS

**GREAT QUALITY IMPACT SOCKETS**



**3/8" DRIVE SAE IMPACT SOCKET SET**



12 PIECE, 6 PT. SET INCLUDES: 5/16, 3/8, 7/16, 1/2, 9/16, 5/8, 11/16, 3/4, 13/16, 7/8, 15/16, 1".

**STOCK NO. SUN3360**

**1/2" DRIVE SAE IMPACT SOCKET SET**



13 PIECE, 6 PT. SET INCLUDES: 7/16, 1/2, 9/16, 5/8, 11/16, 3/4, 13/16, 7/8, 15/16, 1", 1-1/16, 1-1/8, 1-1/4.

**STOCK NO. SUN2650**

**1/2" DRIVE SAE DEEP IMPACT SOCKET SET**



13 PIECE, 6 PT. SET INCLUDES: 7/16, 1/2, 9/16, 5/8, 11/16, 3/4, 13/16, 7/8, 15/16, 1", 1-1/16, 1-1/8, 1-1/4.

**STOCK NO. SUN2651**

### ECONOMY TOOLS

#### COMBINATION WRENCHES

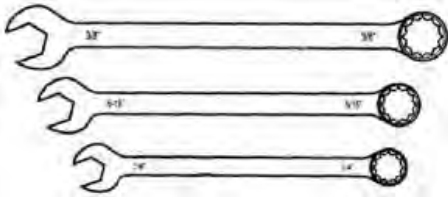

CHROME VANADIUM STEEL. HARDENED AND TEMPERED. SAE 12 POINT.

STOCK NO.	DESCRIPTION
ECOCW03	3/8
ECOCW04	7/16
ECOCW05	1/2
ECOCW06	9/16
ECOCW07	5/8
ECOCW08	11/16
ECOCW09	3/4
ECOCW10	13/16
ECOCW11	7/8
ECOCW12	15/16
ECOCW13	1"

#### JUMBO COMBINATION WRENCHES

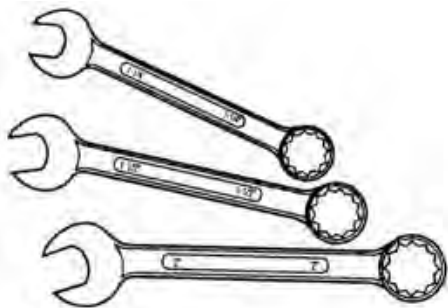

ALLOY STEEL HARDENED AND TEMPERED. NICKEL CHROME. SAE 12 POINT.

STOCK NO.	DESCRIPTION
ECOCW14	1-1/16
ECOCW15	1-1/8
ECOCW16	1-1/4
ECOCW17	1-5/16
ECOCW18	1-3/8
ECOCW19	1-7/16
ECOCW20	1-1/2
ECOCW21	1-5/8
W22	1-11/16
ECOCW23	1-3/4
ECOCW24	1-13/16
ECOCW25	1-7/8
ECOCW26	2"
ECOCW27	2-1/8
ECOCW28	2-1/4
ECOCW29	2-3/8
ECOCW30	2-1/2

**ADDITIONAL ITEMS AVAILABLE UPON REQUEST**

#### ADJUSTABLE WRENCHES



RAISED PANEL DESIGN. PRECISION MACHINED. HARDENED AND TEMPERED.

STOCK NO.	DESCRIPTION	MAX. CAPACITY
ECOAW01	6"	13/16
ECOAW02	8"	1"
ECOAW03	10"	1-3/16
ECOAW04	12"	1-11/32

#### COMBINATION WRENCH SETS

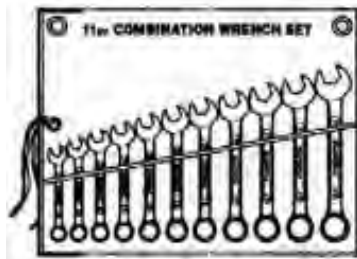

COMBINATION WRENCH SETS. HARDENED AND TEMPERED, CHROME VANADIUM STEEL,

##### 11 PC. SAE COMB. WRENCH SET

STOCK NO.	SIZE
ECOWS01	1/4"-7/8"

##### 14 PC. SAE COMB. WRENCH SET

STOCK NO.	SIZE
ECOWS02	3/8"-1-1/4"

##### 11 PC. METRIC COMB. WRENCH SET

STOCK NO.	SIZE
ECOWS03	7MM-22MM

##### 14 PC. METRIC COMB. WRENCH SET

STOCK NO.	SIZE
ECOWS04	9MM-32MM

##### 6 PC. JUMBO COMB. WRENCH SET

STOCK NO.	SIZE
ECOWS05	1-3/8"-2"

#### PIPE WRENCHES

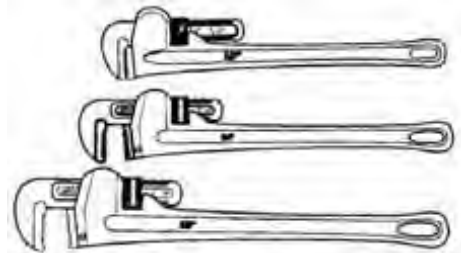

##### STEEL PIPE WRENCHES

ACCURATELY MACHINED, HARDENED AND TEMPERED, DROP FORGED STEEL JAWS AND ADJUSTMENT NUT. MALLEABLE HANDLE WITH HEAVY DUTY ENAMEL FINISH.

STOCK NO. ECOPW03	(14" LENGTH)
STOCK NO. ECOPW04	(18" LENGTH)
STOCK NO. ECOPW05	(24" LENGTH)

##### ALUMINUM PIPE WRENCHES

ACCURATELY MACHINED. DROP FORGED STEEL JAW AND ADJUSTMENT NUT. HEAVY DUTY, CAST ALUMINUM ALLOY HANDLE. INDUSTRIAL QUALITY.

STOCK NO. ECOAPW03	(14" LENGTH)
STOCK NO. ECOAPW04	(18" LENGTH)
STOCK NO. ECOAPW05	(24" LENGTH)
STOCK NO. ECOAPW06	(36" LENGTH)
STOCK NO. ECOAPW07	(48" LENGTH)

**ADDITIONAL ITEMS AVAILABLE UPON REQUEST**

**GIVE US A CALL FOR ALL YOUR NEEDS**



ECONOMY TOOLS

**3/8" DRIVE SOCKET SET  
12 PT. STANDARD & 12 PT. DEEP  
20 PIECES**

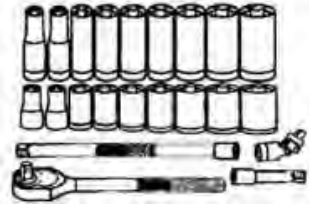

STOCK NO.	DESCRIPTION
PTW38911	7 PC. STD. 3/8"-3/4" SOCKET 7 PC. DEEP 3/8" - 3/4" SOCKET 5/8" & 13/16" SPARK PLUG SOCKET 8" RATCHET HANDLE 3" & 6" EXTENSION BARS UNIVERSAL, BLOW MOLD CASE

**3/8" DRIVE METRIC SOCKET SET  
6 PT. STANDARD & 6 PT. DEEP  
23 PIECES**

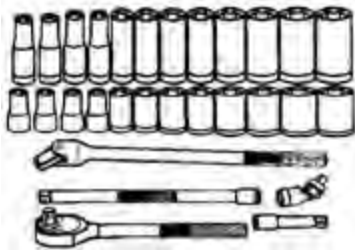

STOCK NO.	DESCRIPTION
PTW38914	8 PC. STD. 10MM-19MM SOCKET 8 PC. DEEP 10MM-19MM SOCKET 16MM & 21MM SPARK PLUG SOCKETS 8" RATCHET HANDLE 3" & 6" EXTENSION BARS 7-7/8" BREAKER BAR MOLDED PLASTIC CASE

**1/2" DRIVE SOCKET SET  
12 PT. STANDARD  
17 PIECES**

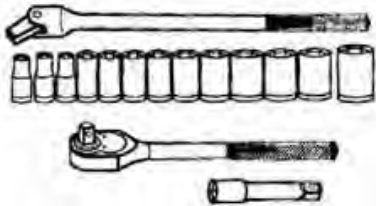

STOCK NO.	DESCRIPTION
OLY09917	13 PC. STD. 7/16"-1-1/4" SOCKETS 10" RATCHET HANDLE 14-1/2" BREAKER BAR 5" EXTENSION BAR MOLDED PLASTIC CASE

**1/2" DRIVE METRIC SOCKET SET  
12 PT. STANDARD  
17 PIECES**

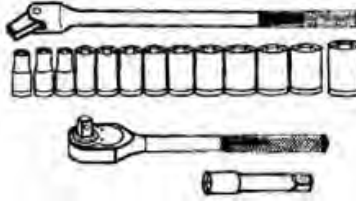

STOCK NO.	DESCRIPTION
OLY09918	13 PC. STD. 10MM-27MM SOCKET 10" RATCHET HANDLE 14-1/2" BREAKER BAR 5" EXTENSION BAR MOLDED PLASTIC CASE

**1/4" SOCKET WRENCH SET  
6 PT. STANDARD & 6 PT. DEEP  
21 PIECES**



STOCK NO.	DESCRIPTION
WAR36006	9 PC. STD. 3/16"-1/2" SOCKET 7 PC. DEEP 1/4" - 1/2" SOCKET 5/8" & 13/16" SPARK PLUG SOCKET RATCHET WITH QUICK RELEASE 6" SPINNER EXTENSION HANDLE 4" SLIDING T-BAR 3" & 6" EXTENSION BARS MOLDED PLASTIC CASE

**3/8" SOCKET WRENCH SET  
12 PT. STANDARD  
12 PIECES**



STOCK NO.	DESCRIPTION
WAR36002	9 PC. STD. 3/8"-7/8" SOCKET 5/8" SPARK PLUG SOCKET RATCHET WITH QUICK RELEASE 3" EXTENSION BARS MOLDED PLASTIC CASE

**3/8" SOCKET WRENCH SET  
12 PT. STANDARD & 6 PT. DEEP  
20 PIECES**



STOCK NO.	DESCRIPTION
WAR36004	9 PC. STD. 3/8"-7/8" SOCKET 8 PC. DEEP 3/8" - 13/16" SOCKET RATCHET WITH QUICK RELEASE 3" & 6" EXTENSION BARS MOLDED PLASTIC CASE

**1/2" SOCKET WRENCH SET  
12 PT. STANDARD  
17 PIECES**



STOCK NO.	DESCRIPTION
WAR36003	14 PC. STD. 3/8"-1-1/4" SOCKET RATCHET WITH QUICK RELEASE 5" EXTENSION HANDLE 16" SPEED HANDLE MOLDED PLASTIC CASE

**3/8" METRIC SOCKET WRENCH SET  
6 PT. STANDARD & 6 PT. DEEP  
20 PIECES**



STOCK NO.	DESCRIPTION
WAR36005	9 PC. STD. 10MM-22MM SOCKET 8 PC. DEEP 10MM-19MM SOCKET RATCHET WITH QUICK RELEASE 3" & 6" EXTENSION BARS MOLDED PLASTIC CASE

**RATCHETS**

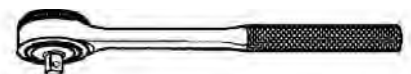

STOCK NO.	DESCRIPTION	LENGTH OVERALL	DRIVE
ECOR02	STEEL HANDLE	8"	3/8
ECOR03	STEEL HANDLE	10"	1/2

### ECONOMY TOOLS

#### FLAT HEAD SCREWDRIVERS

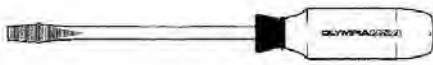

CELLULOSE ACETATE MAKEUP MAKES FOR AN IMPACT RESISTANT HANDLE. CHROME VANADIUM STEEL BLADES.

STOCK NO.	TIP WIDTH	BLADE LENGTH	OVERALL LENGTH
ECOSD01	3/16	3"	6-3/4
ECOSD02	3/16	6"	9-1/8
ECOSD03	1/4	4"	7-5/8
ECOSD04	1/4	6"	9-5/8
ECOSD05	5/16	6"	10-1/2
ECOSD06	3/8	8"	13-1/4

#### PHILLIPS HEAD SCREWDRIVERS

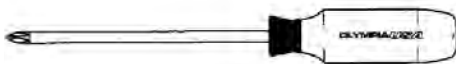

STOCK NO.	TIP WIDTH	BLADE LENGTH	OVERALL LENGTH
ECOPSD01	#1	3"	6-3/4
ECOPSD02	#2	4"	8-3/8

#### 7-PIECE SAE SOLID NUT DRIVER SET



THIS SET OF MOST COMMONLY USED FRACTION NUT DRIVERS WILL HELP YOU WITH NUT OR BOLT APPLICATIONS FOR MOST EVERYDAY JOBS. SET INCLUDES 1 EACH: 3/16 X 3", 1/4 X 3", 5/16 X 3", 11/32 X 3", 3/8 X 3", 7/16 X 3", 1/2 X 3"..

STOCK NO. IR81046

#### CURVED JAW LOCKING PLIERS

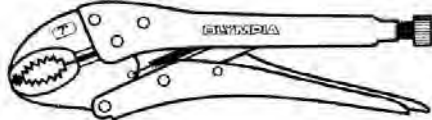

BOTH SIZES HAVE CURVED JAWS AND WIRE CUTTERS. SIMPLY TURN THE MICRO-ADJUSTING SCREW TO SET JAWS FOR PROPER SIZE AND PRESSURE, OR FOR PLIERS ACTION.

STOCK NO.	SIZE	JAW THICKNESS	JAW ADJUSTMENT
ECOVG01	7"	5/16	1-5/8
ECOVG02	10"	3/8	1-7/8

#### LONG NOSE LOCKING PLIERS WITH WIRE CUTTER

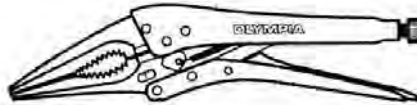

LONG NOSE JAWS REACH INTO TIGHT SPOTS WHERE OTHER TOOLS CAN'T. BUILT-IN WIRE CUTTER. ADJUSTS EASILY FOR PROPER LOCKING PRESSURE.

STOCK NO.	SIZE
ECOVG03	6"
ECOVG04	9"

#### LOCKING C-CLAMP

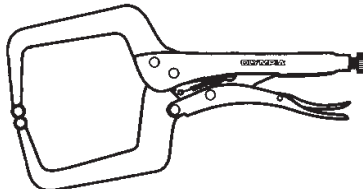

DROP FORGED JAWS. HEAT TREATED NICKLE PLATED.

STOCK NO.	SIZE
ECOVG05	11"

#### LONG NOSE PLIERS

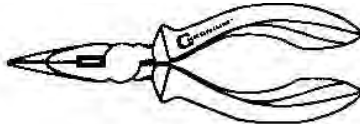

SOLID JOINT PLIERS. PRECISION MACHINED JAW. HARDENED AND TEMPERED.

STOCK NO. ECOP01	(6" NEEDLE NOSE)
STOCK NO. ECOP02	(8" NEEDLE NOSE)

#### DIAGONAL CUTTERS

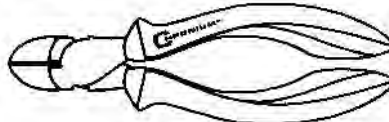

PERFECTLY MATED CUTTERS. PRECISION MACHINED JAW. HARDENED AND TEMPERED.

STOCK NO. ECOP04	(6" LAP JOINT)
STOCK NO. ECOP05	(7" H.D. LAP JOINT)

#### LINEMAN'S PLIERS



DROP FORGED HIGH CARBON STEEL. HEAT TREATED METAL HARDENED AND TEMPERED.

STOCK NO.	SIZE
ECOP08	8"

#### SOLID RUBBER Mallet



BLACK RUBBER HEAD AND A HARDWOOD HANDLE.

STOCK NO.	HEAD WEIGHT	HANDLE LENGTH
PTM7132	32 OZ.	13"

#### DEAD BLOW HAMMERS

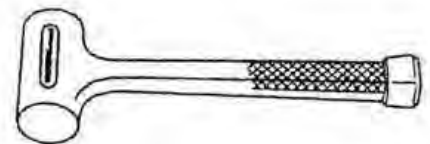

STEEL FRAME AND HOLLOW CORE HEAD WITH NON-MARKING PLASTIC JACKET. STEEL SHOT FILLED HEAD ELIMINATES REBOUND AND VIBRATIONS.

STOCK NO.	HEAD WEIGHT
HAM30	16 OZ.
HAM31	24 OZ.
HAM32	32 OZ.
HAM33	48 OZ.
HAM34	64 OZ.

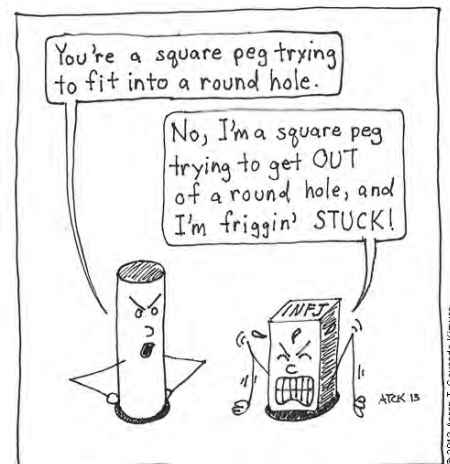

© 2013 Aaron T. Caycedo-Kimura



**HEX KEYS**



**FOLD-UP HEX KEY SETS**



INCH AND METRIC

STOP SEARCHING FOR THE RIGHT SIZE HEX KEY. CHOOSE FROM SEVEN HANDY FOLD-UP SETS, EACH WITH A SERIES OF HEX KEY SIZES. KEYS ARE TOP QUALITY 8650 CHROME NICKEL ALLOY STEEL, DRAWN TO A TOLERANCE OF +.000-.001, WITH SQUARE-CUT, AND SHARP HEX CORNERS FOR PRECISE FIT TO HEX SOCKETS. PRECISION HARDENED AND TEMPERED FOR EXTRA TORQUE.

**INCH SIZES**

STOCK NO.	DESCRIPTION	HANDLE LENGTH
EK20811	(SMALL) .050, 1/16, 5/64 3/32, 7/64, 1/8, 9/64, 5/32	3"
EK20912	(SMALL) .050, 1/16, 5/64 3/32, 7/64, 1/8, 9/64, 5/32 3/16	3-5/8
EK20911	(MEDIUM) 5/64, 3/32, 7/64 1/8, 9/64, 5/32, 3/16, 7/32 1/4	4-1/4
EK20511	(LARGE) 3/16, 7/32, 1/4 5/16, 3/8	5-1/4
EK20812	(EXTRA-LONG) 3/32, 7/64 1/8, 9/64, 5/32, 3/16, 7/32 1/4	5-1/4

**METRIC SIZES**

EK21171	(SMALL) 1.5, 2, 2.5, 3 4, 5, 6MM (92.1MM)	3-5/8
EK21172	(MEDIUM) 2, 2.5, 3, 4 5, 6, 8MM (108 MM)	4-1/4
EK21151	(LARGE) 3, 4, 5, 6, 8, 10MM (133.3 MM)	5-1/4

**5-IN-1 FOLD UP  
SCREWDRIVER SET NO.45**

ALL IN ONE UNIT. FOLDS TO POCKET SIZE.



HARDENED AND TEMPERED. HIGH QUALITY TOOL STEEL. SET INCLUDES: #1 PHILLIPS TYPE, 1/4" FLAT BLADE, 3/16" FLAT BLADE, 1/8" FLAT BLADE, 3/16" POINT AWL.

STOCK NO. EK22451

**FOLD-UP TORX KEY SET**



SEVEN MOST POPULAR TORX KEYS IN ONE CONVENIENT HANDLE. ELIMINATES SEARCHING FOR THE RIGHT TOOL. EACH KEY CAN BE USED STRAIGHT OUT OR AT RIGHT ANGLES FOR EXTRA LEVERAGE. THEY ARE MADE OF TOP QUALITY CHROME NICKEL ALLOY STEEL, PRECISION MACHINED AND HARDENED FOR LONG LIFE AND PRECISE FIT.

**STOCK NO. DESCRIPTION**

EK22571	STANDARD - 7 PC. SET T10, T15, T20, T25, T27, T30, T40
EK22572	SMALL - 7 PC. SET T6, T7, T8, T9, T10, T15, T20



THIS IS A COMPREHENSIVE CATALOG OF OUR MAJOR LINES AND SERVICES, BUT IT DOES NOT SHOW ALL AVAILABLE PRODUCT LINES. IF THERE IS SOMETHING YOU NEED THAT IS NOT SHOWN, WE EITHER CARRY IT OR CAN GET IT. PLEASE CALL US FOR INFORMATION.

**CALL US FOR ALL YOUR NEEDS**  
**855-785-TOOL**

**LONG REACH "T" HANDLE SERVICE KITS**



LONG-REACH (6" OR 9") DESIGN WITH LOOP HANDLES FURNISHED IN STURDY VINYL REUSABLE POUCHES.

**INCH SETS (8 KEYS)**

STOCK NO.	ARM LENGTH	KEY SIZES
EK33168	6"	3/32, 7/64, 1/8, 9/64
EK33198	9"	5/32, 3/16, 7/32, 1/4

**METRIC SETS (5 KEYS)**

STOCK NO.	ARM LENGTH	KEY SIZES
EK35165	152 MM (6")	2.5, 3, 4, 5, 6MM
EK35195	228 MM (9")	2.5, 3, 4, 5, 6 MM

**LONG REACH "T" HANDLE HEX KEY BENCH SETS**



LONG REACH ARMS PROVIDE ACCESS TO HARD TO REACH SOCKETS WITHOUT TIME WASTING DISASSEMBLY. KEYS ARE HIGH QUALITY 8650 CHROME NICKEL ALLOY STEEL, PRECISION DRAWN FOR CLOSE TOLERANCE TO INSURE SECURE FIT INTO SCREW SOCKETS. HARDENED AND TEMPERED BY EKLIND'S EXCLUSIVE SPECIAL MAR TEMPERING PROCESS FOR MAXIMUM STRENGTH. CONTINUOUS 1 PIECE INTEGRAL LOOP HANDLES ARE CORRECTLY PROPORTIONED FOR REQUIRED LEVERAGE.

**SETS W/ STAND (10 KEYS)**

STOCK NO.	ARM LENGTH	KEY SIZES
EK30160	6"	3/32, 7/64, 1/8, 9/64, 5/32, 3/16, 7/32, 1/4, 5/16, 3/8
EK30190	9"	SAME AS ABOVE

**METRIC SETS W/ STAND (8 KEYS)**

STOCK NO.	ARM LENGTH	KEY SIZES
36168	152MM (6")	2, 2.5, 3, 4, 5, 6, 8, 10MM
36198	228MM (9")	SAME AS ABOVE



INDIVIDUAL HEX KEYS & HEX KEY SETS



T-HANDLE VINYL GRIP SET WITH STAND



13 PIECE SET INCLUDES SIZES .050\*, 1/16\*, 5/64, 3/32, 7/64, 1/8, 9/64, 5/32, 3/16, 7/32, 1/4, 5/16, & 3/8. ALL IN 6" LENGTH EXCEPT FOR \* ITEMS WHICH ARE "L" SHAPED.

STOCK NO. EK60614

LONG REACH "T" HANDLE HEX KEY

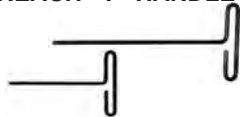

STOCK NO. 6" ARM	STOCK NO. 9" ARM	HEX WIDTH (ACROSS FLATS)	HANDLE WIDTH
EK31606	EK31906	3/32	3"
EK31607	EK31907	7/64	3"
EK31608	EK31908	1/8	3"
EK31609	EK31909	9/64	3"
EK31610	EK31910	5/32	3"
EK31612	EK31912	3/16	4"
EK31614	EK31914	7/32	4"
EK31616	EK31916	1/4	4"
EK31620	EK31920	5/16	6"
EK31624	EK31924	3/8	6"

BALL END CADDY SETS



BALL END HEX KEY WRENCHES PERMIT EASY ACCESS EVEN IN RESTRICTED OR HARD TO REACH AREAS. MADE FROM 8650 TOP GRADE ALLOY STEEL. SURFACES ARE TREATED FOR RUST AND CORROSION RESISTANCE. HEAT TREATED AND TEMPERED FOR ADDED STRENGTH.

STOCK NO.	DESCRIPTION
EK13213	13-PC. LONG INCH SERIES .050 - 3/8"
EK13609	9-PC. LONG METRIC SERIES 1.5 - 10mm

SHORT SERIES HEX KEYS\*



ENGLISH MEASURE. INDIVIDUAL SIZES. THE SHORT ARM ALLOWS EASIER ACCESS IN TIGHT SPOTS.

STOCK NO.	SIZE	STOCK NO.	SIZE
HK01	.028	HK11	7/32
HK02	.035	HK12	1/4
HK035	1/16	HK13	5/16
HK04	5/64	HK14	3/8
HK05	3/32	HK15	1/2
HK06	7/64	HK435	1-1/8
HK07	1/8	HK44	1-1/4
HK08	9/64	HK45	1-1/2
HK09	5/32	HK46	1-3/4
HK10	3/16		

\*NOT EKLIND

LONG SERIES HEX KEYS\*



ENGLISH MEASURE. INDIVIDUAL SIZES. IDEAL FOR THOSE HARD TO REACH APPLICATIONS.

STOCK NO.	SIZE	STOCK NO.	SIZE
HK24	.050	HK34	1/4
HK25	1/16	HK35	5/16
HK26	5/64	HK36	3/8
HK27	3/32	HK37	7/16
HK28	7/64	HK38	1/2
HK29	1/8	HK39	9/16
HK30	9/64	HK40	5/8
HK31	5/32	HK41	3/4
HK32	3/16	HK42	7/8
HK33	7/32	HK43	1"

\*NOT EKLIND

13 PIECE HEX KEY SETS



STOCK NO.	DESCRIPTION
EK10213	13 PC. HEX-L KEY SET INCH SIZES: .050 - 3/8 LONG SERIES IN PLASTIC HOLDER
EK10113	13 PC. HEX-L KEY SET INCH SIZES: 0.50 - 3/8 SHORT SERIES IN PLASTIC HOLDER

15 PIECE HEX KEY POUCHED SET\* LONG ARM



NYLON ROLL UP. 1 EA. OF THE FOLLOWING: 5/64, 3/32, 7/64, 1/8, 9/64, 5/32, 3/16, 7/32, 1/4, 5/16, 3/8, 1/2, 9/16, 5/8, 3/4

STOCK NO. ALLEN56014 \*NOT EKLIND

SHORT SERIES METRIC HEX KEYS\*



STOCK NO.	SIZE	STOCK NO.	SIZE
M676	1.5MM	M686	10MM
M677	2MM	M687	11MM
M678	2.5MM	M688	12MM
M679	3MM	M689	14MM
M680	4MM	M690	17MM
M681	5MM	M691	19MM
M682	6MM	M692	22MM
M683	7MM	M693	24MM
M684	8MM	M694	27MM
M685	9MM	M695	32MM
		M6951	36MM

\*NOT EKLIND

LONG SERIES METRIC HEX KEYS



STOCK NO.	SIZE	STOCK NO.	SIZE
EK15602	1.3MM	EK15612	6MM
EK15603	1.5MM	EK15616	8MM
EK15604	2.0MM	EK15620	10MM
EK15605	2.5MM	EK15624	12MM
EK15606	3.0MM	EK15628	14MM
EK15608	4.0MM		
EK15610	5.0MM		

QUALITY PRODUCTS, FAIR AND COMPETITIVE PRICES AND EXCELLENT SERVICE IS OUR REPUTATION.





**INDIVIDUAL HEX KEYS & HEX KEY SETS**



**9 PIECE METRIC HEX-L KEY SETS**



**STOCK NO.** DESCRIPTION  
**EK10509** 9 PC. HEX-L KEY SET  
 METRIC SIZES: 1.5MM-10MM  
 SHORT SERIES IN PLASTIC HOLDER

**EK10609** 9 PC. HEX-L KEY SET  
 METRIC SIZES: 1.5MM-10MM  
 LONG SERIES IN PLASTIC  
 HOLDER

**22 PIECE INCH & METRIC  
 HEX KEY SET**



22 PIECE HEX-L KEY SET WITH LONG INCH  
 (.050 - 3/8") AND LONG METRIC (1.5 - 10mm)  
 SERIES IN PLASTIC HOLDER.

**STOCK NO. EK10222**  
**STOCK NO. EK13222** (BALL END)

**HEX-L KEY METAL BOX SETS**



**STOCK NO.** DESCRIPTION  
**EK10118** 18 PC-HEX-L KEY SET  
 INCH SIZES: .028 - 5/8  
 SHORT SERIES IN METAL BOX  
**EK10515** 15 PC.-HEX-L KEY SET  
 METRIC SIZES: 0.7MM - 17MM  
 SHORT SERIES IN METAL BOX  
**EK10214** 14 PC.-HEX-L KEY SET  
 INCH SIZES: .050 -1/2  
 LONG SERIES IN METAL BOX  
**EK10610** 10 PC.-HEX-L KEY SET  
 METRIC SIZES: 1.5MM - 12.0MM  
 LONG SERIES IN METAL BOX

**ERGO-FOLD KEY SETS**

ERGO-FOLD KEY SETS FEATURE A COMPOSITE  
 GRIP HANDLE SHAPED FOR SUPERIOR  
 ERGONOMICS.



STOCK NO.	INCH SIZES DESCRIPTION	HANDLE LENGTH
<b>EK25912</b>	(SMALL) .050, 1/16, 5/64, 3/32, 7/64, 1/8, 9/64, 5/32, 3/16	3-3/4"
<b>EK25911</b>	(MEDIUM) 5/64, 3/32, 7/64 1/8, 9/64, 5/32, 3/16, 7/32 1/4	4-1/2
<b>EK25611</b>	(LARGE) 5/32, 3/16, 7/32 1/4, 5/16, 3/8	5-1/2



STOCK NO.	METRIC SIZES DESCRIPTION	HANDLE LENGTH
<b>EK25171</b>	(SMALL) 1.5, 2, 2.5, 3, 4 5, 6 MM	3-3/4
<b>EK25161</b>	(LARGE) 3, 4, 5, 6, 8 10 MM	5-1/2



STOCK NO.	TORX SIZES DESCRIPTION	HANDLE LENGTH
<b>EK25581</b>	(MEDIUM) T8, T10, T15 T20, T25, T27, T30, T40	4-1/2

**INDIVIDUAL BALL END HEX KEYS**



FRACTIONAL		METRIC	
STOCK NO.	SIZE	STOCK NO.	SIZE
<b>EK18203</b>	.050	<b>EK18604</b>	2MM
<b>EK18204</b>	1/16	<b>18606</b>	3MM
<b>EK18205</b>	5/64	<b>EK18608</b>	4MM
<b>EK18206</b>	3/32	<b>EK18610</b>	5MM
<b>EK18207</b>	7/64	<b>EK18612</b>	6MM
<b>EK18208</b>	1/8	<b>18614</b>	7MM
<b>EK18209</b>	9/64	<b>EK18616</b>	8MM
<b>EK18210</b>	5/32	<b>18618</b>	9MM
<b>EK18212</b>	3/16	<b>EK18620</b>	10MM
<b>EK18214</b>	7/32	<b>18622</b>	11MM
<b>EK18216</b>	1/4	<b>EK18624</b>	12MM
<b>EK18220</b>	5/16	<b>18628</b>	14MM
<b>EK18224</b>	3/8	<b>18634</b>	17MM

**3 PC. COMBINATION HEX KEY SETS**



STOCK NO.	SET NO.	DESCRIPTION
<b>EK94000</b>	20511	3/16, 7/32, 1/4, 5/16 3/8
	20911	5/64, 3/32, 7/64, 1/8 9/64, 5/32, 3/16, 7/32 1/4
	21171	1.5, 2, 2.5, 3, 4, 5 6MM

# RIDGID

## PIPE WORKING TOOLS

# RIDGID

### HEAVY-DUTY PIPE WRENCH



STRAIGHT PIPE WRENCHES WITH STURDY, CAST-IRON HOUSING AND I-BEAM HANDLE WITH FULL FLOATING HOOK JAW, NONSTICK ADJUSTMENT NUT AND REPLACEABLE HOOK AND HEEL JAWS. INSTANT GRIP, INSTANT RELEASE.

- STOCK NO. RID31000 (6" LENGTH, 3/4" CAP.)
- STOCK NO. RID31005 (8" LENGTH, 1" CAP.)
- STOCK NO. RID31010 (10" LENGTH, 1-1/2" CAP.)
- STOCK NO. RID31015 (12" LENGTH, 2" CAP.)
- STOCK NO. RID31020 (14" LENGTH, 2" CAP.)
- STOCK NO. RID31025 (18" LENGTH, 2-1/2" CAP.)
- STOCK NO. RID31030 (24" LENGTH, 3" CAP.)
- STOCK NO. RID31035 (36" LENGTH, 5" CAP.)
- STOCK NO. RID31040 (48" LENGTH, 6" CAP.)

### HEAVY-DUTY END PIPE WRENCH

ASSURES A FAST AND EASY GRIP FOR PIPE



WORKING IN RESTRICTED SPACES OR CLOSE TO A WALL.

- STOCK NO. RID31070 (14" LENGTH, 2" CAP.)
- STOCK NO. RID31075 (18" LENGTH, 2-1/2" CAP.)

### ALUMINUM HANDLE STRAIGHT PIPE WRENCHES



ALUMINUM HANDLES MAKE THESE HEAVY-DUTY WRENCHES ALMOST 40% LIGHTER THAN SIMILAR WRENCHES WITH CAST-IRON HANDLES. PARTS ARE IDENTICAL TO RIDGID HEAVY-DUTY STRAIGHT WRENCHES. IDEAL FOR OVERHEAD WORK.

- STOCK NO. RID31090 (10" LENGTH, 1-1/2" CAP.)
- STOCK NO. RID47057 (12" LENGTH, 2" CAP.)
- STOCK NO. RID31095 (14" LENGTH, 2" CAP.)
- STOCK NO. RID31100 (18" LENGTH, 2-1/2" CAP.)
- STOCK NO. RID31105 (24" LENGTH, 3" CAP.)
- STOCK NO. RID31110 (36" LENGTH, 5" CAP.)
- STOCK NO. - (48" LENGTH, 6" CAP.)

### PARTS FOR RIDGID PIPE WRENCHES

HOOK JAW	HEEL JAW & PIN	ADJUSTMENT NUT
31555 (6")	31560 (6")	31570 (6")
31580 (8")	31585 (8")	RID31595 (8")
RID31605 (10")	RID31610 (10")	RID31615 (10")
RID31630 (12")	RID31635 (12")	31645 (12")
RID31655 (14")	RID31635 (14")	RID31665 (14")
RID31670 (18")	RID31675 (18")	RID31685 (18")
RID31695 (24")	RID31700 (24")	RID31710 (24")
RID31720 (36")	RID31725 (36")	RID31735 (36")
31745 (48")	RID31750 (48")	31760 (48")
31770 (60")	31755 (60")	31785 (60")

### HEAVY-DUTY CHAIN WRENCHES



A DOUBLE JAW ALLOWS FAST RATCHET TYPE ACTION IN EITHER DIRECTION.

REPLACEABLE ALLOY STEEL JAWS. IDEAL FOR USE IN CLOSE QUARTERS.

- STOCK NO. RID31310 (2" RATED CAP. 4" ACTUAL O. D. CAP. 15-3/4" CHAIN LENGTH)
- STOCK NO. RID31320 (2-1/2" RATED CAP. 5" ACTUAL O.D. CAP. 20-1/4" CHAIN LENGTH)
- STOCK NO. RID31325 (3" RATED CAP. 5" ACTUAL O.D. CAP. 20-1/4" CHAIN LENGTH).
- STOCK NO. RID31330 (4-1/2" RATED CAP. 7-1/2" ACTUAL O.D. CAP. 29" CHAIN LENGTH)

### STRAP WRENCHES



BEST FOR ANY POLISHED PIPE. STRONG, WOVEN NYLON STRAP GIVES TIGHT GRIP.

- STOCK NO. RID31345 (1/8" THRU 2" CAP. 1-1/8" x 30" STRAP)
- STOCK NO. RID31365 (1" THRU 5" CAP. 1-3/4" x 48" STRAP)

### REPLACEMENT STRAPS

- STOCK NO. RID32050 (#5, 29")
- STOCK NO. RID32055 (#5, 48")
- STOCK NO. RID32025 (#2, 30")

### HEAVY-DUTY PIPE CUTTERS



GIVES FAST, CLEAN PIPE CUTTING BY HAND OR POWER. EXTRA LONG SHANK PROTECTS ADJUSTMENT THREADS. EXTRA LARGE HANDLE FOR QUICK, EASY ADJUSTMENT. CAN CONVERT TO 3-WHEEL CUTTER BY REPLACING ROLLERS WITH CUTTER WHEELS.

- STOCK NO. RID32820 (2-A MODEL, 1/8-2" CAP.)

42-A IS SIMILAR TO 2-A, BUT HAS 4 HEAVY-DUTY WHEELS AND SHORT HANDLE. DESIGNED FOR AREAS WHERE A COMPLETE TURN IS IMPOSSIBLE.

- STOCK NO. RID32870 (42-A MODEL, 3/4-2" CAP.)



THE 4-S MODEL HAS A LARGE HANDLE WHICH ASSURES GRIP AND HAS EASY ADJUSTMENT. SECOND HANDLE GIVES ADDED LEVERAGE FOR LARGE SIZE PIPE CUTTING JOBS. CAN BE CONVERTED TO 3-WHEEL CUTTER BY REPLACING ROLLERS WITH CUTTER WHEELS.

- STOCK NO. RID32840 (4-S MODEL, 2-4" CAP.)

### SPIRAL RATCHET PIPE REAMER



SELF-FEEDING SPIRAL DESIGN FOR EXTRA-FAST AND EASY HAND REAMING. THIS MODEL IS NOT SUITABLE FOR USE WITH POWER DRIVES. COMPLETE WITH HANDLE. 1/4" - 2" CAPACITY. 2-S MODEL.

- STOCK NO. RID34955

### STRAIGHT FLUTE PIPE REAMER



LONG TAPER DESIGN WILL NOT DIG IN. SUITABLE FOR USE WITH POWER DRIVES. 1/8" - 2" CAPACITY. #2 MODEL.

- STOCK NO. RID34945

### EXPOSED RATCHET DROP HEAD THREADER SETS



NPT SETS INCLUDE RATCHET AND HANDLE WITH INDIVIDUAL DIE HEADS.

- STOCK NO. RID36375 (1/8-1" CAP. 5 HEAD SET) 00-R MODEL
- STOCK NO. RID36475 (1/2-2" CAP. 6 HEAD SET) 12-R MODEL

### EXPOSED RATCHET THREADER HEADS



00-R MODEL (NPT) ALLOY R.H.

- STOCK NO. RID36875 (PIPE SIZE 1/8")
- STOCK NO. RID36880 (PIPE SIZE 1/4")
- STOCK NO. RID36885 (PIPE SIZE 3/8")
- STOCK NO. RID36890 (PIPE SIZE 1/2")
- STOCK NO. RID36895 (PIPE SIZE 3/4")
- STOCK NO. RID36900 (PIPE SIZE 1")

12-R MODEL (NPT) ALLOY R.H.

- STOCK NO. 37375 (PIPE SIZE 1/8")
- STOCK NO. 37380 (PIPE SIZE 1/4")
- STOCK NO. 37385 (PIPE SIZE 3/8")
- STOCK NO. RID37390 (PIPE SIZE 1/2")
- STOCK NO. RID37395 (PIPE SIZE 3/4")
- STOCK NO. RID37400 (PIPE SIZE 1")
- STOCK NO. RID37405 (PIPE SIZE 1-1/4")
- STOCK NO. RID37410 (PIPE SIZE 1-1/2")
- STOCK NO. RID37415 (PIPE SIZE 2")

**RIDGID**

**PIPE THREADING & TUBE CUTTING TOOLS**

**RIDGID**

**RATCHETS AND HANDLES COMPLETE**



STOCK NO. RID38540 (00-R MODEL)  
STOCK NO. RID38555 (12-R MODEL)

**RATCHET THREADER DIES**



DIES FOR 00-R AND 12-R. NPT ALLOY STEEL- R.H.

STOCK NO. NOMINAL PIPE SIZE  
THREADS PER INCH

RID37815	1/4-18"
RID37820	3/8-18"
RID37825	1/2-14"
RID37830	3/4-14"
RID37835	1"-11-1/2"
RID37840	1-1/4-11-1/2"
RID37845	1-1/2-11-1/2"
RID37850	2"-11-1/2"

**RATCHET THREADERS**

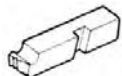

DIES FOR 65R-C AND 65R-TC. HIGH SPEED STEEL.

STOCK NO. RID38100 (NPT- 1" THRU 2"-11-1/2")

**UNIVERSAL ALLOY DIE SETS**



FOR MACHINE DIES 811 THRU 855 (NPT) R.H.

STOCK NO. NOMINAL PIPE SIZE  
THREADS PER INCH

RID47735	1/8-27
RID47740	1/4-3/8 x 18
RID47745	1/2-3/4 x 14
RID47750	1"-2" x 11-1/2"

**PLASTIC TUBE CUTTER**



DESIGNED FOR QUICK, CLEAN CUTS THROUGH PLASTIC PIPE. THESE CUTTERS FEATURE COMPOUND LEVERAGE RATCHET MECHANISMS AND HARDENED STEEL BLADES. ONE-HAND OPERATION PRODUCES QUICK, CLEAN CUTS WITH EASE. DO NOT USE TO CUT PLASTIC COATED PIPE OR TUBING.

STOCK NO. RID91125 (1/8-1-1/2 O.D. CAPACITY)

HIGHWAY SPEED SIGN: "SPEED LIMIT 65 FOR MOST CARS AND SOME TRUCKS UNDER 8,000 POUNDS--ONLY IF THEY'RE EMPTY, UNLESS YOU WEIGH OVER 300 POUNDS--THEN DIVIDE BY SIX. FOR ADDITIONAL INFORMATION CALL THE IRS, WHICH HELPED WRITE THIS."

**TUBING CUTTERS**

150 SERIES TUBING CUTTERS WITH ENCLOSED FEED SCREW AND GROOVED ROLLS.



FEATURES AN ENCLOSED FEED SCREW TO ELIMINATE CLOGGING AND JAMMING. GROOVED ROLLS FOR CLOSE-TO-FLARE CUTS AND FOLD AWAY REAMER. SPARE CUTTER WHEEL IN HANDLE. HIGH STRENGTH ALUMINUM ALLOY CONSTRUCTION. 2 ROLLER FEATURE.

FOLD AWAY REAMER. SPARE CUTTER WHEEL IN HANDLE. HIGH STRENGTH ALUMINUM ALLOY CONSTRUCTION. 2 ROLLER FEATURE.

STOCK NO. RID31622 (MODEL 150. 1/8-1-1/8 CAP.)



"J" SHAPED DESIGN, QUICK ACTING PUSH HANDLE AND TOP RELEASE NUT. TROUBLE FREE.

STOCK NO. RID31632 (MODEL 151 1/4-1-5/8 CAP.)  
STOCK NO. RID31652 (MODEL 154 1-7/8-4-1/2 CAP.)



OFFERS ALL OF THE ADVANTAGES OF THE 150 PLUS THE QUICK ACTING FEATURE OF THE 151 FOR FAST, CLEAN CUTS. CUTTER ALWAYS TURNS ON TWO

OF THE FOUR ROLLERS FOR EASY OPERATION. WITH HEAVY-DUTY WHEEL.

STOCK NO. RID33070 (MODEL 205. 1/4-2-3/8 CAP.)



FOR USE IN HARD-TO-GET-AT PLACES. COMPACT DESIGN SMALL ENOUGH TO USE INSIDE AIR CONDITIONING UNITS AND APPLIANCES. ENCLOSED FEED REQUIRES ONLY 1-1/4"

CLEARANCE. TWO FRICTION REDUCING STEEL ROLLERS. CUTTER WHEEL REPLACEABLE.

STOCK NO. GEN123R (1/8-5/8" CAP.)  
STOCK NO. GEN121RW (REPLACEMENT CUTTER WHEEL)

**REPLACEMENT CUTTER WHEELS**



STOCK NO.	WHEEL TYPE	FITS MODEL NO.	APPLICATION
RID33160	THIN	10, 15, 20	ALUM/COP.
RID33165	H/D	10, 15, 20	STEEL
RID33170	THIN	30, 154	ALUM/COP.
RID33175	H/D	30, 154	STEEL
RID33185	STD.	150, 151, 205	ALUM/COP.
RID33190	H/D	150, 151, 205	STEEL
RID33200	SE174	150	SOFT PLASTIC

**PIPE CUTTER WHEELS**

STOCK NO.	WHEEL TYPE	FITS MODEL NO.	APPLICATION
RID33100	THIN	1A, 2A	STEEL PIPE
RID33105	H/D	1A, 2A	STEEL PIPE
RID33125	H/D	4S	STEEL PIPE

**CUTTER WHEEL PIN CLIP**

STOCK NO. RID32142

**THREAD CUTTING OILS**



COOLS THREADS AND PIPE DURING OPERATION. SPEEDS METAL REMOVAL. IDEAL FOR STAINLESS STEEL. PROTECTS DIES; GET BETTER THREADS. AVAIL. DARK OR NU-CLEAR

NU-CLEAR  
STOCK NO. RID41565 (QUART)  
STOCK NO. RID70835 (GALLON)  
STOCK NO. RID41575 (5 GALLON)

DARK  
STOCK NO. RID41590 (QUART)  
STOCK NO. RID70830 (GALLON)  
STOCK NO. RID41600 (5 GALLON)

**PIPE VISE**



PORTABLE TRI-STAND TOP SCREW CHAIN VISE. 1/8" THRU 5" PIPE CAPACITY. BUILT-IN TRAY MAKES FOLDING LEGS EXTRA-RIDGID WHEN OPEN. BASE OVERHANGS FRONT LEGS FOR CLEAR TOOL SWING. HAS 3 PIPE BENDERS. ADJUSTABLE CEILING BRACE SCREW.

STOCK NO. RID72037

HAVING TROUBLE FINDING SOMETHING?  
GIVE US A CALL.  
WE WILL BE MORE THAN HAPPY TO ASSIST YOU!

# RIDGID

## FLARING, BENDING AND KNOCKOUT TOOLS

# RIDGID

### FLARING TOOLS

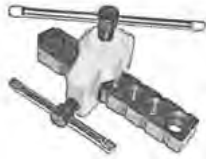

A QUALITY MADE FLARING TOOL THAT ACCURATELY FLARES 7 SIZES: 3/16", 1/4", 5/16", 7/16", 1/2" AND 5/8" (METRIC CONFIGURATION 6, 8, 10, 12, 14, 15, 16MM). O.D. IN SOFT COPPER, BRASS, ALUMINUM AND MILD STEEL TUBING.

**STOCK NO. RID23337** (WITH ADAPTERS FOR DOUBLE LAP FLARES 3/16", 1/4", 5/16", 3/8", 1/2" O.D. TUBING AND CASE KIT)

**STOCK NO. RID24797** (WITH NO. 105 TUBING CUTTER AND CASE KIT)



ADVANCE DESIGN GIVES SMOOTH UNIFORM FLARES ON STEEL, STAINLESS STEEL, HARD COPPER AND BRASS WITH MINIMUM EFFORT. LARGE COMFORT-GRIP FEED SCREW HANDLE. HARDENED STEEL FLARING CONE MOUNTED IN PRECISION BEARINGS PRODUCES ROLLING ACTION FOR EVEN METAL FLOW. SUITABLE FOR HYDRAULICS.

**STOCK NO. RID41162 (MODEL 377)**. CAP. 3/16", 1/4", 5/16", 3/8", 1/2", 5/8", 3/4"

**STOCK NO. RID41285 (MODEL 375)**. CAP. 1/2", 5/8", 3/4", 7/8", 1"



HINGED TYPE FLARING TOOL DESIGNED TO HANDLE ALL POPULAR SIZES OF TUBING. THE YOKE COMPRESSOR IS MADE OF A STEEL DROP FORGING AND EASILY SLIPS OVER THE DIE BLOCK. HARDENED FLOATING CONE PRODUCES AN EVEN, ACCURATE FLARE AND TAPER THAT WILL INSURE A TIGHT JOINT. SEVEN FLARING DIES: 3/16", 1/4", 5/16", 3/8", 7/16", 1/2" AND 5/8".

**STOCK NO. CTA970**

### DOUBLE FLARE ADAPTERS

**STOCK NO.**

**CTA9200X01** (3/16")  
**9200X02** (1/4")  
**9200X03** (5/16")  
**9200X04** (3/8")  
**9200X05** (1/2")

### DOUBLE FLARING TOOL KIT



DESIGNED TO WITHSTAND THE HIGH PRESSURE NECESSARY TO DOUBLE FLARE SOFT STEEL TUBING AND SINGLE FLARE SOFT COPPER, ALUMINUM OR BRASS. COMES COMPLETE WITH YOKE COMPRESSOR, FIVE DOUBLE FLARE ADAPTERS, A BAR ASSEMBLY WITH FIVE THREADED HOLDERS (3/16", 1/4", 5/16", 3/8", 1/2"), AND A HANDY STORAGE BOX.

**STOCK NO. CTA9200**

### TUBE BENDER



WILL BEND TUBING OF UP TO 1/4" DIAMETER TO 360 DEGREES; FAST AND EASY AND WITHOUT KINKS. FOR COPPER, BRASS, BRAKE LINES, ETC. DURABLE, NON-CORRODING. CHEMICALLY POLISHED ZINC DIE CASTING. 5" LENGTH.

**STOCK NO. CTA978**

### TRI-BENDER



BENDS 1/4", 5/16" AND 3/8" O.D. TUBING OF ANNEALED COPPER, ALUMINUM, STEEL AND STAINLESS STEEL. IDEAL FOR PLUMBING AND HVAC APPLICATIONS.

**STOCK NO. RID44852**

### DRAIN CLEANER



QUICKLY UNCLOGS SINKS, TUBS, AND SHOWERS. THE HAND SPINNER IS DESIGNED TO QUICKLY AND THOROUGHLY CLEAR BLOCKAGES IN SINKS, TUBS, AND SHOWERS.

**STOCK NO. RID59807**

### LEVER TUBING BENDER



COMBINES ACCURACY AND EASY OPERATION. BENDS COPPER, STEEL AND STAINLESS STEEL TO 180 DEGREES. SOLID OFFSET HANDLES WITH CUSHION GRIPS AND BUILT-IN VISE MOUNT. 400 SERIES.

**STOCK NO. RID36122 (MODEL 404)** (1/4" O.D.)

**STOCK NO. RID36097 (MODEL 406)** (3/8" O.D.)

**STOCK NO. RID36132 (MODEL 408)** (1/2" O.D.)

### MANUAL KNOCKOUT SETS



RIDGID'S UNIQUE THREE-POINT DESIGN MAKES PUNCHING FAST AND SIMPLE. BLANKS FALL OUT EASILY, WITHOUT PRYING. RIDGID DIES AND PUNCHES ARE AVAILABLE INDIVIDUALLY OR IN SETS, AND ARE INTERCHANGEABLE WITH MOST KNOCKOUT SYSTEMS.

\*PRECISION GROUND THREE-POINT PUNCHES  
 \*CAPACITY 2" IN 10 GAUGE MILD STEEL  
 \*HEAVY-DUTY BALL BEARING DRIVE SCREWS  
 \*SETS INCLUDE DURABLE ABS STORAGE CASE  
 \*THREE SETS AVAILABLE, INCLUDING DELUXE RATCHET DRIVE

**MODEL R735BB:** 1/2"-1-1/4" BALL BEARING SET WITH CASE

**STOCK NO. RID31787**

**MODEL R737BB:** 1-1/2"-2" BALL BEARING SET WITH CASE

**STOCK NO. RID31792**

**MODEL R739BB:** 1/2"-2" BALL BEARING SET WITH RATCHET WRENCH AND CASE

**STOCK NO. RID31797**

### MANUAL KNOCKOUT DRAWBOLTS

**STOCK NO. RID31802** (3/8")

**STOCK NO. RID55722** (3/4")

### CONDUIT KNOCKOUT PUNCHES

**STOCK NO. RID17497** (1/2" CONDUIT, 7/8" DIA.)

**STOCK NO. RID55522** (3/4" CONDUIT, 1-1/8" DIA.)

**STOCK NO. RID55652** (2" CONDUIT, 2-7/16" DIA.)

### CONDUIT KNOCKOUT DIES

**STOCK NO. RID17547** (1/2" CONDUIT, 7/8" DIA.)

**STOCK NO. RID55527** (3/4" CONDUIT, 1-1/8" DIA.)

**SPECIAL PURPOSE TOOLS**

**INSPECTION MIRROR**



OVAL MIRROR 1" x 2" WITH PLATED MIRROR CASE AND CHROME PLATED STEEL HANDLE. OVERALL LENGTH 8-1/2". COPPER BACKED FOR CLEAR VIEWING. BALL JOINTS TO CONTROL ANGLE.

**STOCK NO. RIM0910**

**STOCK NO. RIM0911** (REPLACEMENT MIRROR)

**TELESCOPIC INSPECTION MIRRORS**



CIRCULAR MIRROR 2-1/4" DIAMETER WITH PLATED MIRROR CASE. PLATED TELESCOPIC STEEL AND BRASS HANDLE. OVERALL LENGTH EXTENDED IS 14".

**STOCK NO. CTA9454**



RECTANGULAR MIRROR 2-1/8" x 3-1/2" WITH PLATED MIRROR CASE. PLATED TELESCOPIC STEEL AND BRASS HANDLE. OVERALL LENGTH EXTENDED IS 15".

**STOCK NO. CTA9456**

**STOCK NO. RIM0931** (REPLACEMENT MIRROR)

**TELESCOPIC POCKET MIRROR**



CIRCULAR MIRROR 1-1/4" DIAMETER. EXTENDS TO 21", CLOSES TO 7". BRASS AND CHROME PLATED WITH BALL JOINT TO CONTROL ANGLE. FURNISHED WITH HANDY POCKET CLIP.

**STOCK NO. CTA9450**

**TELESCOPIC MAGNETIC TOOL**



EXTENDS TO 26-1/2", CLOSES TO 16". DOUBLE JOINTED FINGER WITH POWERFUL MAGNETIC TIP THAT CAN REACH AROUND CORNERS AND EXTRACT OBJECTS FROM THE TIGHTEST PLACES. BRIGHTLY POLISHED. SHOCK PROOF PLASTIC COVERED HANDLE.

**STOCK NO. CTA9433**

**POCKET MAGNET**



STRONG 6" ALL-PURPOSE MAGNET THAT CLIPS INTO POCKET. BRIGHTLY POLISHED, LIGHT WEIGHT ALUMINUM SHAFT WITH EASY-GRIP KNURLED HANDLE.

**STOCK NO. RIM0830**

**TELESCOPIC POCKET MAGNET**



EXTENDS TO 18-5/16". CLOSES TO 5-3/4" AND CLIPS INTO POCKET LIKE A PENCIL. ALL-PURPOSE MAGNET CAN EXTRACT OBJECTS FROM TIGHT PLACES. BRIGHTLY POLISHED; STRONG MAGNETIC TIP.

**STOCK NO. CTA9430**

**FLEXIBLE MECHANICAL FINGER**



VERSATILE TOOL THAT FEATURES A LONG, FLEXIBLE "MEMORY CABLE" AND STRONG STEEL JAWS THAT REACH INTO TIGHT PLACES TO HOLD SCREWS, BOLTS AND OTHER OBJECTS IN POSITION. STURDY CONSTRUCTION. OVERALL LENGTH 24".

**STOCK NO. GEN396**

**AMAZING POCKET REFERENCE MANUALS**



BEST-SELLING 3RD EDITION MINI-BOOK HAS PAGES OF TABLES, MAPS, FORMULAS, CONSTANTS AND CONVERSIONS. A MUST FOR EVERY STUDENT, CONTRACTOR OR ENGINEER. 3.2" x 5.4" x .7" BOOK FITS IN POCKET.

**STOCK NO. REF1**

THIS EDITION MINI-BOOK IS GEARED MORE TOWARD THE HANDYMAN. 750 PAGES OF INFORMATION BENEFICIAL TO EVERY STUDENT, CONTRACTOR AND HANDYMAN.



**STOCK NO. REF2**

**HAVING THE RIGHT TOOL IS HALF THE JOB!**



**DON'T DO A HALF @@ JOB!**

**MECHANIC'S STETHOSCOPE**

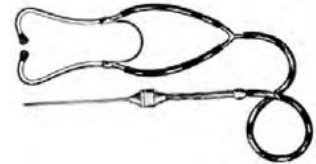

PROVIDES A FAST, ACCURATE METHOD OF LOCATING TROUBLES IN ENGINE AND OTHER MOVING PARTS SUCH AS PISTON SLAP, WORN GEARS, FAULTY VALVES, WATER PUMP FAILURE, DAMAGED GASKETS, DEFECTIVE BEARINGS AND BODY SQUEAKS.

**STOCK NO. CTA2015**

**BATTERY BRUSH**



INTERNAL AND EXTERNAL WIRE BRUSHES SET IN AN ACID PROOF PLASTIC CASE. CLEANS BOTH TERMINALS AND POSTS. WILL NOT CORRODE OR SOFTEN IN CLEANING SOLUTIONS.

**STOCK NO. CTA3115**

**NOT SURE  
 ABOUT  
 SOMETHING?  
 GIVE US A CALL!  
 ONE OF OUR  
 ASSOCIATES  
 WILL BE  
 MORE THAN  
 HAPPY  
 TO HELP  
 YOU OUT.**

### SPECIAL PURPOSE TOOLS

#### PICKER-OUTER



THE TOOL WITH MANY USES. REMOVES STUBBORN AND HARD-TO-REACH COTTER PINS, BITS OF GLASS, WIRE, STAPLES, ETC. HAMMER FORGED STEEL SHAFT AND COMFORTABLE PLASTIC HANDLE. OVERALL LENGTH 7".

STOCK NO. MAY31010

#### UNIVERSAL OIL FILTER WRENCH



FOR REMOVING DISPOSABLE OIL FILTERS 3-7/16" TO 3-3/4" IN DIAMETER. WILL NOT PUNCTURE OR CRUSH FILTER. OPERATES IN CLOSE QUARTERS.

STOCK NO. AP75530

FOR SMALLER FILTERS 2-13/16" TO 3-5/32" IN DIAMETER:

STOCK NO. AP75533

## ASSISTANCE



## IS A PHONE CALL AWAY!

YOU ARE NEVER A LOSER UNTIL YOU QUIT TRYING.

--MIKE DITKA

#### NUT CRACKER



QUICKLY REMOVES RUSTED OR CORRODED NUTS IN HARD-TO-REACH PLACES SUCH AS ON SWAY BARS, SHOCK ABSORBERS AND IN BUMPER CHANNELS. EASY TO USE. REQUIRES ONLY A 3/4" WRENCH TO OPERATE. HEAT TREATED AND PLATED. COMPACT. WILL SPLIT NUTS UP TO 3/4" ACROSS THE FLAT. **DO NOT USE WITH POWER TOOLS.**

STOCK NO. RIM0400

#### GREASE FITTING TOOL

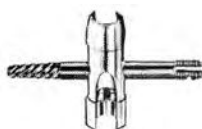

TIGHTENS OR REMOVES BROKEN ALEMITE PIN TYPE FITTINGS, BROKEN FITTINGS AND EVEN RETHREADS CROSSED THREADS. FEATURES INCLUDE A HANDY 1/8" PIPE TAP AND 7/16" & 3/8" SOCKET OPENINGS.

STOCK NO. RIM0051

#### BRAKE & SMALL ENGINE CYLINDER HONE



RANGE 3/4" TO 2-1/2". ADJUSTABLE CUTTING TENSION. FAST AND CONVENIENT WITH WIDE RANGE AND FLEXIBLE JOINT DRIVE. DESIGNED FOR BRAKE CYLINDER RESURFACING AND OFFERS EASY CUTTING WITH HIGH AND LOW SPEED DRILLS. DESIGNED TO BOTTOM IN BLIND HOLES OR RESURFACE STEP CYLINDERS. COMES COMPLETE WITH THREE MEDIUM GRIT 1-1/8" STONES. OVERALL LENGTH 8".

STOCK NO. CTA1110

#### REPLACEMENT STONE SETS (COTTER PINS INCLUDED WITH SETS)

MEDIUM GRIT 1-1/8" -  
STOCK NO. CTA1115 (SET OF THREE)  
FINE GRIT 1-1/8" -  
STOCK NO. CTA1117 (SET OF THREE)

#### SMALL CYLINDER HONE



RANGE 1/2" TO 2-1/4". ADJUSTABLE CUTTING TENSION. SELF-ALIGNING; SELF-CENTERING. FLEXIBLE JOINT DRIVE. COMES COMPLETE WITH TWO MEDIUM GRIT 1-1/8" STONES.

STOCK NO. CTA1120

REPLACEMENT STONE SET (MED. GRIT 1-1/8")  
STOCK NO. CTA1125 (SET OF TWO)

#### GLAZE BREAKERS



THE NEW IMPROVED DEGLAZING AND RESURFACING HONES ARE DESIGNED FOR FAST, ACCURATE HONING OF CYLINDERS. A SPREAD LIMITER LIMITS HONE DIAMETER FOR GENERAL WORK OR EXPANDS HONE FOR LARGE DIAMETER CYLINDERS. SPRING ACTION GIVES THE CORRECT PRESSURE FOR POSITIVE GLAZE BREAKING USING HIGH OR LOW SPEED 1/4" THROUGH 1/2" DRILLS. SELF-CENTERING AND SELF-BOTTOMING. COMES COMPLETE WITH THREE MEDIUM GRIT STONES.

RANGE 1-1/4" TO 3-1/2". ADJUSTABLE CUTTING TENSION. 10" LENGTH. 3" STONES (3 EACH).  
STOCK NO. CTA2300

RANGE 2" TO 7". ADJUSTABLE CUTTING TENSION. 12" LENGTH. 4" STONES (3 EACH).  
STOCK NO. CTA2310

#### REPLACEMENT STONE SETS (COTTER PINS INCLUDED WITH SETS)

MEDIUM GRIT 3" -  
STOCK NO. CTA2318 (SET OF THREE)

FINE GRIT 3" -  
STOCK NO. CTA2319 (SET OF THREE)

COARSE GRIT 3" -  
STOCK NO. CTA2320 (SET OF THREE)

MEDIUM GRIT 4" -  
STOCK NO. CTA2315 (SET OF THREE)

#### GASKET SCRAPERS



REMOVES SHELLACKED GASKETS AND CARBON FROM CYLINDER HEADS WITH EASE. HAMMER FORGED ALLOY STEEL BLADE. KNIFE-LIKE EDGE STANDS UP UNDER TOUGH PUNISHMENT. 5/16" SQUARE SHANK, 11-7/8" OVERALL LENGTH.

STOCK NO.      BLADE WIDTH

MAY11110            3/4  
MAY11111            1"  
MAY11112            1-1/2

LET US HELP YOU WITH SPECIAL APPLICATION PRODUCTS. IF IT'S NOT IN THIS CATALOG, IT'S UP TO US TO GET IT FOR YOU.

**PULLERS, SPECIAL PURPOSE TOOLS**

**TWO-JAW PULLERS**



4" ADJUSTABLE. CAN BE USED FOR PULLING MAGNETOS AND GENERATOR BEARINGS AND SMALL GEARS. IDEAL FOR ELECTRIC MOTORS AND REFRIGERATION APPLICATIONS. JAWS HAVE TWO POSITION ADJUSTMENT ALLOWING EXTRA REACH. 4" SPREAD, 3-1/2" REACH, 2-TON CAPACITY.

**STOCK NO. CTA8000**



7" ADJUSTABLE. THIS MID-RANGE PULLER HAS TWO ADJUSTABLE WIDE FAN JAWS FOR TWO POSITION PULLING. 7" SPREAD, 5-1/2" REACH, 5-TON CAPACITY.

**STOCK NO. CTA8010**



10" ADJUSTABLE. THIS PULLER HAS THREE POSITION ADJUSTMENTS TO INCREASE OR DECREASE REACH. CAN BE USED FOR FLY WHEEL, GEAR OR PULLEY REMOVAL. 10" SPREAD, 9" REACH, 7-TON CAPACITY.

**STOCK NO. CTA8020**

**BEARING SPLITTERS**

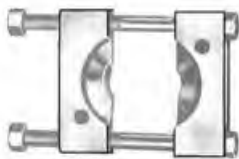

DESIGNED FOR REMOVING GENERATOR GEARS, BEARINGS AND SIMILAR PARTS WHERE ORDINARY JAW PULLERS WILL NOT REACH.

**STOCK NO. CTA8060** (0 TO 2-1/4" JAW OPENING)  
**STOCK NO. CTA8065** (0 TO 4-1/4" JAW OPENING)

**TWO & THREE-JAW COMBO PULLERS**



6" REVERSIBLE TWO-JAW PULLER. DESIGNED FOR MAXIMUM SAFETY AND UTILITY. THE REVERSIBLE JAWS HAVE WIDE FACES ON ONE END AND NARROW FACES ON THE OTHER. 6" SPREAD, 3-1/2" REACH, 5-TON CAPACITY.

**STOCK NO. CTA8005**



9" REVERSIBLE TWO-JAW PULLER. DESIGNED FOR HEAVY-DUTY PULLING ON AUTOMOTIVE AND INDUSTRIAL APPLICATIONS. JAWS ARE REVERSIBLE AND ONE END HAS SLOTS FOR CAP SCREW PULLING OF GEARS AND PULLEYS. 9" SPREAD, 5-1/2" REACH, 7-TON CAPACITY.

**STOCK NO. CTA8015**



OFFERS A LOT OF VERSATILITY FOR SMALL AND TOUGH PULLING JOBS. THREE JAWS FOR ADDED STABILITY PLUS EACH JAW HAS TWO SETS OF HOLES TO VARY THE REACH. IDEAL FOR REMOVING MOTOR, MAGNETO AND GENERATOR BEARINGS AND GEARS. 4" SPREAD, 3-1/2" REACH, 2-TON CAPACITY.

**STOCK NO. CTA8035**



11" ADJUSTABLE TWO & THREE JAW PULLER IDEAL FOR HARD-TO-GET-AT-PLACES. EACH JAW HAS THREE HOLES FOR EXTRA STRETCH. 11" SPREAD, 9" REACH, 7-TON CAPACITY.

**STOCK NO. CTA8055**



7" REVERSIBLE TWO & THREE JAW PULLER. CONVERTS EASILY AND PROVIDES A THREE POINT GRIP WHEN MORE STABILITY AND PULLING POWER IS REQUIRED. 7" SPREAD, 3-1/2" REACH, 5-TON CAPACITY.

**STOCK NO. CTA8040**



10" REVERSIBLE TWO & THREE JAW PULLER. HEAVY-DUTY. CONVERTS EASILY. 10" SPREAD, 5-1/2" REACH, 7-TON CAPACITY.

**STOCK NO. CTA8050**

**PUNCH AND CHISEL HOLDER**



DESIGNED FOR GETTING INTO TIGHT PLACES WITHOUT HITTING HANDS OR FINGERS. NON-SLIP COMFORTABLE PLASTIC HANDLE. NYLON TIP ON SHAFT HOLDS TIGHT AGAINST PUNCH OR CHISEL ABSORBING IMPACT.

**STOCK NO. RIM0925**

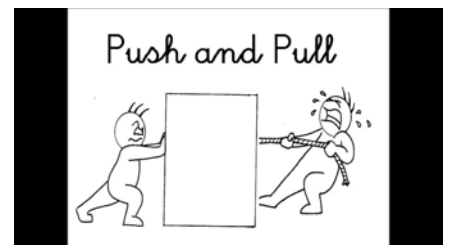

# VAUGHAN

## COMMERCIAL BALL PEIN HAMMERS



POLISHED FACE, BEVEL AND PEIN. RUST RESISTANT BLACK PAINT ON OTHER SURFACES. COMPRESSION -WEDGED HICKORY HANDLE.

STOCK NO.	HEADWEIGHT	LENGTH
VBS702	2 OZ.	10"
VBTC504	4 OZ.	10-1/4
VBTC308	8 OZ.	12"
VBTC2012	12 OZ.	12-3/4
VBTC016	16 OZ.	13-3/4
VBTC120	20 OZ.	15"
VBTC224	24 OZ.	15-1/4
VBTC432	32 OZ.	15-3/4
VBTC640	40 OZ.	16"
VBTC848	48 OZ.	16"

## FIBERGLASS BALL PEIN HAMMERS



STRIKING HEAD, CHEEKS AND PEIN HIGHLY POLISHED. EXCLUSIVE HOLLOW-CORE FIBERGLASS HANDLE PROVIDES BETTER BALANCE AND ABSORBS SHOCK MORE EFFECTIVELY THAN SOLID FIBERGLASS. STEEL WEDGED AND EPOXY SEALED EYE ASSEMBLY. NEOPRENE GRIP.

STOCK NO.	HEADWEIGHT	LENGTH
VBFS308	8 OZ.	12-1/2
VBFS2012	12 OZ.	13"
VBFS016	16 OZ.	13"
VBFS224	24 OZ.	14-1/2
VBFS432	32 OZ.	14-3/4

## BLACKSMITH/ENGINEER'S HAMMER



DROP FORGED. TEMPERED FACE AND CROSS PEIN. LARGE FACE AND WIDE BEVEL MINIMIZE CHIPPING. FINE HICKORY HANDLE.

STOCK NO.	HEADWEIGHT	LENGTH
VBS32	2 LBS.	14-1/2
VBS40	2-1/2 LBS.	15-1/2"
VBS48	3 LBS.	16"

## SOLID RUBBER MALLET



1-1/4 LB. WEIGHT, 10-5/8" LENGTH.  
STOCK NO. VBRM2B

## CARPENTER'S HALF HATCHET



FULL-POLISHED HEAD 3-1/2" CUT. SELECT FLAME-TREATED HICKORY HANDLE.

22 OZ. HEADWEIGHT, 13" LENGTH  
STOCK NO. VBSH2

## SCOUT (CAMP) AXE



LIGHT WEIGHT AND EASY TO CARRY. HEAD IS GROUND SMOOTH, WITH A RUST RESISTANT BLACK FINISH. FINE, FLAME-TREATED HICKORY HANDLE. 1-1/4 LB. HEADWEIGHT, 14" LENGTH.

STOCK NO. VBSC114

## BRICKLAYER'S HAMMER



FORGED HIGH CARBON STEEL. GRADE "A" CLEAR HICKORY HANDLE.

16 OZ. WEIGHT, 11" LENGTH.  
STOCK NO. VBBL16

## SPLIT HEAD RAWHIDE FACE HAMMER



NEW DESIGN, MALLEABLE IRON HEADS HAVE EASY TO CHANGE FACES THAT CAN BE ROTATED FOR LONGER WEAR. TOP QUALITY HICKORY HANDLES ARE SECURED WITHOUT WEDGING.

STOCK NO.	SIZE	FACE DIA.	HEAD LGTH.	APPROX. WT. (LBS.)
VBSH150	2	1-1/2	5-1/8	2
VBSH175	3	1-3/4	5-1/2	3-1/4
VBSH275	5	2-3/4	6-1/2	8

## RAWHIDE HAMMER FACES



STOCK NO.	VB150RF	(SIZE #2)
STOCK NO.	VB175RF	(SIZE #3)
STOCK NO.	VB275RF	(SIZE #5)

## RAWHIDE REPLACEMENT HANDLES



STOCK NO.	VB59502	(#2 11-3/4" LENGTH)
	59504	(#3 12-1/2" LENGTH)
STOCK NO.	VB59508	(#5 15-1/2" LENGTH)

## CURVED CLAW NAIL HAMMERS ECONOMY GRADE



FINE HICKORY HANDLE.

STOCK NO. VBDD16 (16 OZ.)

## CURVED CLAW NAIL HAMMERS



SOLID STEEL.

STOCK NO. VBR16 (16 OZ.)  
STOCK NO. VBR20 (20 OZ.)



OCTAGON FIBERGLASS HAMMER. HANDLE ABSORBS SHOCK AND PROVIDES BALANCE. STEEL WEDGED; EPOXY SEALED EYE.

STOCK NO. VBFS16 (16 OZ.)  
STOCK NO. VBFS20 (20 OZ.)

## "999" PRO-SERIES RIP HAMMERS

THE "999" PATTERN RIP HAMMER HAS EXTRA STEEL BEHIND THE STRIKING FACE, A DEEP THROAT, FULL-POLISHED HEAD AND OCTAGON NECK, AND SMOOTHLY SWEPT CLAWS.



PRO-16 FIBERGLASS. 16 OZ. WEIGHT, 13-1/2" LENGTH.

STOCK NO. VBFS99  
999 FIBERGLASS. 20 OZ. WEIGHT, 14" LENGTH.



STOCK NO. VBFS999  
999 TUBULAR STEEL. 20 OZ. WEIGHT, 14" LENGTH.

STOCK NO. VB999T

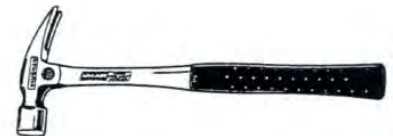

999 SOLID STEEL. 20 OZ. WEIGHT, 14" LENGTH.  
STOCK NO. VBR999



INDUSTRIAL HAMMERS, SLEDGES AND AXES

BLACKSMITHS' OR ENGINEERS' HAMMERS & DOUBLE-FACE SLEDGES



THIS IS THE MOST COMMONLY USED TYPE OF SLEDGE HAMMER. ALL PATTERNS HAVE CROWNED STRIKING FACES WITH BEVELED EDGES.

STOCK NO.	WEIGHT* (HEAD)	EYE SIZE	TOOL FACE LGTH.	HNDLE LGTH.
HAM03	2-1/2	3/4 x 1"	4-3/8	1-3/8 16"
HAM04	3	3/4 x 1"	5"	1-1/2 16"
HAM05	4	3/4 x 1"	5-1/4	1-3/4 16"
HAM06	6	1" x 1-3/8	6"	2-1/8 36"
HAM07	8	1" x 1-3/8	6-1/2	2-1/4 36"
HAM08	10	1" x 1-3/8	7"	2-1/2 36"
HAM09	12	1" x 1-3/8	7-1/2	2-5/8 36"
HAM10	16	1" x 1-3/8	8-1/4	2-7/8 36"
HAM11	20	1-1/4 x 1-1/2	8-3/4	3-1/8 36"

\*WEIGHT IN POUNDS

DOUBLE-FACE ENGINEERS' HAMMER WITH FIBERGLASS HANDLE



DROP FORGED. POLISHED AND TEMPERED FACE. HIGH-IMPACT OVERSTRIKE GUARD. SLIP-RESISTANT GRIP.

STOCK NO.	WEIGHT (HEAD)	TOTAL LGTH.
VBPDF48F	3 LBS.	15-1/4"
VBPDF64F	4 LBS.	15-1/2"

ADDITIONAL MODELS AVAILABLE UPON REQUEST

DOUBLE-FACE SLEDGES FIBERGLASS HANDLES



HIGH CARBON STEEL. HEAT-TREATED. MACHINED, POLISHED FACES.

STOCK NO.	WEIGHT* (HEAD)	HANDLE
HAM13	3	16"
HAM14	4	16"
HAM15	6	16"
HAM18	6	34"
HAM19	8	34"
HAM20	10	34"
HAM21	12	34"
HAM22	16	34"

\*WEIGHT IN POUNDS

AXES

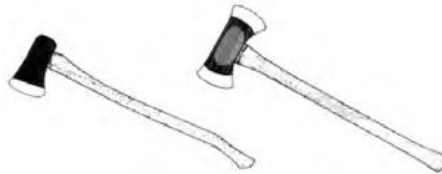

MICHIGAN SINGLE BIT NO. 114

STOCK NO.	NET WEIGHT (HEAD ONLY)	LENGTH
HAM28	3-1/2 LBS.	36"

MICHIGAN DOUBLE BIT NO. 115

STOCK NO.	NET WEIGHT (HEAD ONLY)	LENGTH
HAM29	3-1/2 LBS.	36"

ADDITIONAL MODELS AVAILABLE UPON REQUEST

NEW ENGLAND (SHORT) PATTERN HAND DRILLING HAMMERS



HIGH CARBON STEEL. HEAT-TREATED. MACHINED, POLISHED FACES. TOP GRADE HANDLE.

STOCK NO.	WEIGHT	FACE	HANDLE LENGTH
OLY62223	3 LBS.	1-1/2	10-1/2
WAR01006	4 LBS.	1-5/8	10-1/2

SQUARE HEAD WEDGES NO. 120



HIGH CARBON STEEL.

STOCK NO.	HEAD WEIGHT	LENGTH	HEAD	BIT
WAR03601	3 LBS.	8"	1-1/2	1-3/4
WAR03602	4 LBS.	9"	1-5/8	1-7/8
WAR03603	5 LBS.	9-1/2	1-3/4	2"





**SPECIALTY NON-MARRING HAMMERS**



**RAWHIDE MALLETS, HAMMERS AND FACES**

ECONOMICAL QUALITY-CRAFTED HAMMERS FOR INDUSTRY. TOUGH, RESILIENT WATER BUFFALO RAWHIDE FACES ARE LONG-WEARING AND DURABLE. COMPLETELY SAFE ON STEEL, IRON, BRASS OR SOFT ALUMINUM. NO KICK-BACKS, SCARS, DENTS, CHIPS OR SPLINTERS.

**RAWHIDE Mallet**



IDEAL FOR ELECTRICAL APPLIANCE, MOTOR MANUFACTURERS AND JEWELERS.

CHOICE WATER BUFFALO RAWHIDE WITH STURDY HARDWOOD HANDLE.

DESIGNED FOR LONG WEAR.

STOCK NO.	SIZE	FACE DIA.	HEAD LGTH.	APPROX. WT.
GA11002	2	1-1/2	3"	6 OZ.
11003	3	1-3/4	3-3/8	9 OZ.
11004	4	2-3/4	4-1/2	22 OZ.

**SOLID HEAD HAMMER**



EASY TAP-OUT CHANGE- NO GRINDING NECESSARY.

PRACTICAL TOOL FOR ANY OPERATION REQUIRING ASSEMBLING, SHAPING, FORGING, LOOSENING OR ADJUSTING.

STOCK NO.	SIZE	FACE DIA.	HEAD LGTH.	APPROX. WT. (LBS)
GA41001	1	1-1/4	3-5/8	1
GA41002	2	1-1/2	4-1/4	1-1/2
GA41003	3	1-3/4	4-7/8	2-1/2
GA41004	4	2"	5-1/4	4
GA41005	5	2-3/4	5-5/8	6-1/4

**RAWHIDE HAMMER FACES**



STOCK NO.	SIZE	DIA.
GA21000*	0	1"
GA21001*	1	1-1/4
GA21002*	2	1-1/2
GA21003*	3	1-3/4
GA21004*	4	2"
GA21005*	5	2-3/4

\*SOLD BY THE PAIR

**SPLIT HEAD HAMMER**



"TURN AND CHANGE" FEATURE- TURN NUT UNDER HEAD, INSERT NEW FACES, SCREW BACK HEAD, AND HAMMER IS LIKE NEW.

KEEPS PERFECT BALANCE.

STOCK NO.	SIZE	FACE DIA.	HEAD LGTH.	APPROX. WT. (LBS)
GA31001	1	1-1/4	3-7/8	1-1/2
GA31002	2	1-1/2	4-1/4	2
GA31003	3	1-3/4	4-3/4	2-3/4
GA31004	4	2"	5-3/8	4
GA31005	5	2-3/4	5-3/4	6-1/2

**URETHANE HAMMER FACES**



- STOCK NO. 23001\* (SIZE #1)
- STOCK NO. GA23002\* (SIZE #2)
- STOCK NO. GA23003\* (SIZE #3)
- STOCK NO. 23004\* (SIZE #4)
- STOCK NO. 23005\* (SIZE #5)

\*SOLD BY THE PAIR

**RAWHIDE REPLACEMENT HANDLES**



- STOCK NO. OPLC10581234 (#3, 12-3/4" LENGTH)
- STOCK NO. OPLC9241312 (#4, 13-1/2" LENGTH)
- STOCK NO. OPLC74216 (#5, 16" LENGTH)

**COMPOTHANE AND SOFT-FACED HAMMERS**



**STANDARD HEAD MODELS**

NON-SPARKING, COMPCO-CAST SOFT-FACED HAMMERS OF UNICAST CONSTRUCTION HAVE NO EXPOSED METAL. THE FACE YIELDS AND DOESN'T MAR SURFACES OR EQUIPMENT. NON-ABSORBENT.

STOCK NO.	WEIGHT (OZ.)	FACE DIA.	HEAD LGTH.	OVERALL LGTH.
STW57530	10	1-1/2	3-1/8	10"
STW57531	18	1-3/4	3-3/4	11"
STW57532	21	2"	4-1/4	12-3/4
STW57533	42	2-1/2	4-3/4	14"
STW57534	52	2-3/4	5-1/4	16"

TOOLS FOR EVERY JOB

**SLIMLINE HEAD MODELS**



NON-SPARKING, COMPO-CAST SLIMLINE HAMMERS OF UNICAST CONSTRUCTION HAVE NO EXPOSED METAL. THE SOFT FACE DOESN'T MAR SURFACES AND IS NON-ABSORBENT. SLIMLINE'S UNIQUE PROFILE IS IDEAL FOR ASSEMBLY AND REPAIR APPLICATIONS IN CONFINED AREAS.

STOCK NO.	WEIGHT (OZ.)	FACE DIA.	HEAD LGTH.	OVERALL LGTH.
57540	6	1"	3"	10"
STW57541	14	1-1/4	4-1/4	10-1/2
STW57542	18	1-1/2	4-1/4	12"
STW57543	21	1-3/4	5-1/4	13"

**SLEDGE MODELS**



NON-SPARKING SOFT-FACED SLEDGE HAMMERS WITH FLAT AREA ON HEAD TO ALLOW UPRIGHT STORAGE. URETHANE COVERING HELPS REDUCE NOISE POLLUTION.

STOCK NO.	WEIGHT (LBS.)	FACE DIA.	HEAD LGTH.	OVERALL LGTH.
STW57550	5.5	2-3/4	7"	20"
STW57551	8	2-3/4	7"	30"

**SOFTFACE HAMMERS**



REPLACEABLE TIPS ARE MADE OF TOUGH PLASTIC THAT WON'T MAR FINELY FINISHED SURFACES. FIBERGLASS HANDLE. TIPS NOT INCLUDED

STOCK NO.	HEADWEIGHT	HANDLE LENGTH
PROTOSF150	8 OZ.	12"
57595	16 OZ.	12"

**REPLACEMENT TIPS**



STOCK NO. PROTOSF15T (8 OZ., MEDIUM)

**SOLID BRASS HAMMERS**



WITH FIBERGLASS HANDLE. AVAILABLE IN COPPER OR LEAD UPON REQUEST.

STOCK NO.	WEIGHT (LBS.)	LENGTH
JM752F	2	12-3/4
JM753F	3	13"
JM754F	4	15"

**REPLACEMENT TOOL HANDLES**

**ADZE EYE NAIL HAMMER**



STOCK NO.	LENGTH	FITS HAMMER SIZE
OPLC10312	12"	7 OZ.
OPLC10413	13"	13 OZ.
OPLC10514	14"	16 OZ.
OPLC102914	14"	20, 22, 24 OZ.

**MACHINIST HAMMER**



STOCK NO.	LENGTH	FITS HAMMER SIZE
OPLC12010	10"	2 OZ.
OPLC9210	10"	4-6 OZ.
OPLC10613	12"	8-12 OZ.
OPLC11114	14"	16-20 OZ.
OPLC20416	16"	24-28 OZ.
OPLC77618	18"	32-48 OZ.
OPLFK77620	20"	32-48 OZ.

**ENGINEERS HAND HAMMER**



STOCK NO.	LENGTH	EYE	FITS HAMMER LBS.
OPLC42215	16"	1" x 3/4	3 - 4
OPLC42316	16"	1" x 3/4	3 - 4
OPLC42318	18"	1" x 3/4	3 - 4

**GARLAND HAMMER**



STOCK NO.	LENGTH	FITS HAMMER SIZE
OPLC10581234	12-3/4"	#3
OPLC9241312	14"	#4
OPLC74216	16"	#5

**BLACKSMITH HAMMER**



STOCK NO.	LENGTH	EYE	FITS HAMMER SIZE
OPLC50316	16"	1-1/4 x 1"	56 OZ. (& HEAVIER)

ADDITIONAL ITEMS AVAILABLE  
UPON REQUEST

**OVAL EYE HAND DRILL HAMMER**



STOCK NO.	LENGTH	OVAL EYE	FITS HAMMER LBS.
OPLC22721012	10-1/2"	1" x 3/4	2 - 4

**HATCHET**



FOR #2 SHINGLING, HALF-HATCHET, CLAW AND #1 BROAD HATCHETS

STOCK NO.	LENGTH
OPLC32414	14"

**SLEDGE HAMMER**



STOCK NO.	LENGTH	FITS HAMMER LBS.
OPLC6830	30"	6 - 8
OPLC61636	36"	6 - 16

**HEAVY SLEDGE HAMMER**

STOCK NO.	LENGTH	EYE	FITS HAMMER LBS.
OPLC182436	36"	1-1/2 x 1-1/4	18 - 24

**FIBERGLASS SLEDGE HAMMER WITH EPOXY**



STOCK NO.	LENGTH	FITS HAMMER LBS.
OPL00170	34"	6 - 16 (SOME 18 - 24 LB. TOOLS)

**BENT SINGLE BIT AXE**



STOCK NO.	LENGTH	FITS HAMMER LBS.
OPLC136	36"	3 - 5

**DOUBLE BIT AXE**



STOCK NO.	LENGTH	FITS HAMMER LBS.
OPLC236	36"	3 - 5

**RAILROAD, CLAY PICK OR MATTOCK**



STOCK NO.	LENGTH	EYE #6	FITS HAMMER LBS.
OPLC28836	36"	3" x 2"	5 (OR HEAVIER)

**D-TYPE SINGLE BENT SHOVEL WITH SHOULDER**



WITH SAW SLOT. 9" EYE CHUCK. 30" LENGTH.  
STOCK NO. OPL82918

**WITHOUT SHOULDER**



WITH SAW SLOT. 9" EYE CHUCK. 30" LENGTH.  
STOCK NO. OPL82518

**SHOVEL**



FEATHERWEIGHT - 5-1/2" SOCKET - 48" LENGTH  
STOCK NO. OPL83618

**BENT SHOVEL**



WITH SAW SLOT - 9" EYE CHUCK - 48" LENGTH  
STOCK NO. OPL82318

**STRAIGHT HOLLOWBACK SHOVEL**



WITH SHOULDER - EYE WITH SLOT  
9" EYE CHUCK - 48" LENGTH  
STOCK NO. OPL87018

THIS SPACE RESERVED  
FOR FUTURE INVENTORY.

### REPLACEMENT TOOL HANDLES AND WEDGES

#### GARDEN HOE



1-1/4" DIAMETER - 3/8" x 3-1/2" BORE 4" FERRULE  
- 52" LENGTH

STOCK NO. OPL19742

#### WHEELBARROW



60" LENGTH - CHERRY STAIN FINISH

STOCK NO. OPL36025

#### LEVEL HEAVY-DUTY RAKE



1-1/4" DIAMETER - 3/8" BORE - 60" LENGTH  
BORED WITH TURNED END FERRULE

STOCK NO. OPL18790

#### POST HOLE DIGGERS



SQUARE EYE- BORED

STOCK NO. OPL10863 (48" LENGTH)  
STOCK NO. OPL86615 (72" LENGTH)

#### BENT MANURE FORK



1-7/16" DIAMETER - 1/2" BORE - 54" LENGTH  
WITH FERRULES AND SQUARE HOLE CAPS

STOCK NO. OPL18716

#### FLOOR SCRAPER



1-3/8" SOCKET STYLE - 3-7/8" CHUCK 48" LENGTH

STOCK NO. OPL90518

#### HAMMER HANDLE WEDGES



CORRUGATED STEEL  
NO. 2 - 5/16" x 13/16" - FOR SMALL HAMMERS  
STOCK NO. OPL2

NO. 3 - 1/2" x 1-1/16" - FOR CARPENTER  
HAMMERS  
STOCK NO. OPL3

NO. 4 - 3/4" x 1-1/16" - FOR LARGE HAMMERS  
STOCK NO. OPL4

NO. 5 - 1" x 1-1/16" - FOR SLEDGE HAMMERS  
STOCK NO. OPL5

#### HAMMER HANDLE WEDGE ASSORTMENT



ASSORTMENT CONSISTS OF:

- 12 PCS.- LR1 WEDGES FOR BLACKSMITH HAMMERS
  - 12 PCS - LR2 WEDGES FOR SLEDGES & MAULS
  - 36 PCS.- #2 WEDGES FOR SMALL HAMMERS
  - 36 PCS.- #3 WEDGES FOR LARGER HAMMERS
  - 36 PCS.- #4 WEDGES FOR HEAVY HAMMERS
  - 36 PCS.- #5 WEDGES FOR SLEDGE HAMMERS
  - 12 PCS.- #18 WEDGES FOR AXES & MAULS
  - 72 PCS.- STEEL RIVETS FOR SHOVELS
- DURABLE STORAGE CASE

STOCK NO. OPLSW204



"HOW WAS YOUR DATE LAST NIGHT, BILLY?" HIS FRIEND ASKED.

"FABULOUS. WE WENT TO THE CONCERT, HAD A BITE TO EAT, AND THEN WE DROVE AROUND FOR A WHILE UNTIL I FOUND A NICE DARK SPOT TO PARK. I ASKED HER FOR A KISS, AND SHE SAID THAT FIRST I'D HAVE TO PUT THE TOP DOWN ON THE CAR. SO I WORKED FOR AN HOUR GETTING THE TOP DOWN--"

"AN HOUR?" INTERRUPTED HIS PAL. "I CAN PUT MY TOP DOWN IN THREE MINUTES."

"I KNOW," SAID BILLY. "BUT YOU HAVE A CONVERTIBLE."

**CUSTOMER  
SATISFACTION  
IS THE KEY  
TO OUR  
SUCCESS**

TWO IRS AGENTS WERE TRAVELING THROUGH A RURAL AREA WHEN THEIR CAR BROKE DOWN. THEY WALKED TO A NEARBY MANSION AND KNOCKED ON THE DOOR. A BEAUTIFUL WIDOW ANSWERED AND SAID THEY WERE WELCOME TO SPEND THE NIGHT WHILE HER HIRED HANDS WORKED ON THE CAR.

MONTHS LATER ONE OF THE AGENTS RECEIVED A PACKAGE OF LEGAL DOCUMENTS. AFTER SURVEYING THE CONTENTS, HE QUICKLY CALLED THE OTHER AGENT.

"WHEN WE WERE UP IN THE COUNTRY," THE FIRST AGENT ASKED, "DID YOU SLIP AWAY IN THE NIGHT AND GO TO THAT WIDOW'S BEDROOM?"

"YES." THE SECOND AGENT ADMITTED.

"DID YOU USE MY NAME?"

"WHY, YES, BUT HOW'D YOU FIND OUT?"

"SHE DIED AND LEFT ME HER ESTATE."

## CHISELS AND PUNCHES

### RIVET BUSTER NO. 220



USED IN CUTTING HEADS FROM RIVETS AND BOLTS OF ALL SIZES. BEVELED TO CUT WITH A SHEARING ACTION.

STOCK NO.	CUTTING EDGE	STOCK SIZE	LENGTH
ENB9	7/8"	3/4"	9"

### COLD CHISELS



USED ONLY FOR CUTTING, SHAPING AND REMOVING METAL SOFTER THAN THE CUTTING EDGE ITSELF SUCH AS CAST IRON, WROUGHT IRON, STEEL, BRONZE, COPPER, ETC.

STOCK NO.	CUTTING EDGE	STOCK SIZE	LENGTH
MAY10200	1/4	1/4	5"
MAY10201	5/16	1/4	5"
MAY10202	3/8	5/16	5-1/2"
ENA4	7/16	3/8	5-1/2"
MAY10205	1/2	7/16	6"
MAY10209	5/8	1/2	6-1/2"
MAY10212	3/4	5/8	7"
MAY10216	7/8	3/4	7-1/2"
MAY10220	1"	7/8	8"
EN0626*	1"	7/8	9"

\*WITH HAND GUARD

### EXTRA-LONG COLD CHISELS



USED IN THE SAME MANNER AS NO. 200 WHERE EXTRA LENGTH IS REQUIRED.

STOCK NO.	CUTTING EDGE	STOCK SIZE	LENGTH
MAY10207	1/2	7/16	12"
MAY10210	5/8	1/2	12"
MAY10213	3/4	5/8	12"
10217	7/8	3/4	12"
MAY10221	1"	3/4	12"
10215	3/4	5/8	18"
MAY10222	1"	3/4	18"

### PUNCH AND CHISEL HOLDER



DESIGNED FOR GETTING INTO TIGHT PLACES WITHOUT HITTING HANDS OR FINGERS. NON-SLIP COMFORTABLE PLASTIC HANDLE. NYLON TIP ON SHAFT HOLDS TIGHT AGAINST PUNCH OR CHISEL ABSORBING IMPACT.

STOCK NO. PROTO2108

### FLOOR CHISELS



DUE TO DESIGN, QUALITY AND TEMPER OF STEEL, THIS CHISEL WILL NOT BREAK OR TAKE A SET WHEN USED AS INTENDED. THE THIN BLADE ENABLES CARPENTER, PLUMBER OR ELECTRICIAN TO CUT TONGUES OFF FLOOR BOARDS AND LIFT THEM (WITHOUT MARRING THE SURFACE). BLADE TEMPERED TO CUT NAILS.

STOCK NO.	CUTTING EDGE	STOCK SIZE	LENGTH
MAY12310	2-1/2	5/8	10-1/2"
MAY12311	3"	3/4	11"

### CENTER PUNCHES



USED FOR MARKING WORK BY INDENTATION FOR STARTING DRILLS IN METAL AND OTHER MATERIALS.

STOCK NO.	POINT SIZE	STOCK SIZE	LENGTH
MAY24000	3/32	1/4	3-1/2"
MAY24001	1/8	5/16	4-1/2"
MAY24002	5/32	3/8	5"
MAY24003	5/16	1/2	6"
MAY24004	3/8	5/8	6-1/4"

### HAND STAR DRILLS



FORGED FROM SPECIAL ANALYSIS ALLOY STEEL. PROPERLY DESIGNED AND TEMPERED TO INSURE LONG, SATISFACTORY SERVICE. USED FOR MAKING HOLES IN MASONRY WALLS SUCH AS CINDER OR CEMENT BLOCK.

STOCK NO.	CUTS	HEX STOCK SIZE	LENGTH
WAR26503	3/8	5/16	12"
WAR26504	1/2	3/8	12"
WAR26505	5/8	7/16	12"
WAR26506	3/4	1/2	12"

### SOLID OR STARTING PUNCHES



USED TO LOOSEN SUCH ITEMS AS FROZEN PINS AND KEYS.

STOCK NO.	POINT SIZE	STOCK SIZE	LENGTH	TAPER
20004	1/16	3/8	5"	1-1/2"
MAY20001	1/8	3/8	5"	1-1/2"
24005	5/32	3/8	5"	1-1/2"
MAY20002	3/16	3/8	5"	1-1/2"
MAY20003	1/4	3/8	5"	1-1/2"
20105	5/16	1/2	6"	2"
MAY20301	3/8	5/8	6-1/2"	2-1/4"
20302	1/2	5/8	7"	2-1/2"

### LINING UP/DRIFT PUNCHES



USED FOR ALIGNING AND SIZING HOLES IN LIGHT GAUGE METAL AND OTHER MATERIALS.

STOCK NO.	POINT SIZE	STOCK SIZE	LENGTH	TAPER
22010	1/8	5/16	8"	3-1/2"
22011	5/32	3/8	9"	4-1/4"
MAY22012	3/16	1/2	10"	6-1/2"
MAY22003	1/4	5/8	12"	7-1/2"
MAY22013	5/16	3/4	12"	7-1/2"
MAY22017	3/8	3/4	15"	8"
22024	1/2	7/8	18"	9-1/2"

### PIN PUNCHES



USED IN DRIVING AND REMOVING SUCH THINGS AS PINS AND KEYS AFTER INITIAL MOVEMENT BY A STARTING PUNCH.

STOCK NO.	POINT SIZE	STOCK SIZE	LENGTH	PIN LENGTH
MAY22236	1/16	1/4	4"	3/4"
MAY22237	3/32	5/16	4-1/2"	1"
MAY22242	1/8	5/16	4-1/2"	1"
MAY22238	5/32	5/16	5"	1"
MAY22239	3/16	3/8	5-1/4"	1-1/8"
MAY21011	7/32	3/8	5-1/2"	1-1/4"
MAY22240	1/4	3/8	6"	1-1/4"
MAY22241	5/16	7/16	6"	1-3/8"
MAY21105	3/8	1/2	6"	1-1/2"

### EXTRA-LONG PIN PUNCHES

STOCK NO.	POINT SIZE	STOCK SIZE	LENGTH	PIN LENGTH
MAY22260	1/8	5/16	8"	3-1/2"
MAY22261	3/16	3/8	8"	3-1/2"
MAY22262	1/4	3/8	8"	3-1/2"
MAY22263	5/16	7/16	8"	3-1/2"
MAY22264	3/8	1/2	8"	3-1/2"

### MASONRY CHISELS WITH STRIKE GUARDS



STOCK NO.	CUT/PT.	STOCK SIZE	OVERALL LENGTH
EN0286	1-1/8	7/8	12"
EN0321	2-1/4	3/4	7-1/2"
EN0314	2-1/2	3/4	7-1/2"
EN0323	2-3/4	3/4	8-1/2"
EN0324	2-3/4	3/4	12"
EN0311	4"	7/8	7"

### CHISEL AND PUNCH KITS, WOOD CHISEL SET

#### 6 PIECE COLD CHISEL KIT



COLD CHISELS: 1/4"  
5/16"  
3/8"  
1/2"  
5/8"  
3/4"

STOCK NO. MAY60560

#### 6 PIECE ROLL PIN PUNCH KIT



ROLL PIN PUNCHES: 1/8"  
5/32"  
3/16"  
7/32"  
1/4"  
5/16"

STOCK NO. MAY62250

#### 14 PIECE PUNCH AND CHISEL KIT

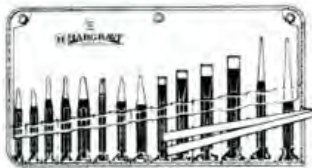

CHISELS:		PUNCHES:	
COLD:	3/8" 1/2" 5/8" 3/4" 7/8"	CENTER:	5/32" 1/4"
		LINE-UP:	1/8" 5/32"
		PIN:	1/16" 1/8" 3/16"
		SOLID:	1/8" 5/16"

STOCK NO. MAY61044

#### 5 PIECE EXTRA-LONG PIN PUNCH SET

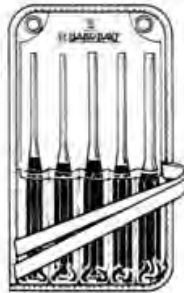

PIN PUNCHES:  
1/8"  
3/16"  
1/4"  
5/16"  
3/8"

STOCK NO. MAY62065

#### 4 PIECE PUNCH AND CHISEL KIT



CHISELS:  
COLD: 1/2"

PUNCHES:  
CENTER: 3/16"  
PIN: 3/16"  
SOLID: 3/16"

STOCK NO. MAY61000

#### 24 PIECE PUNCH AND CHISEL KIT

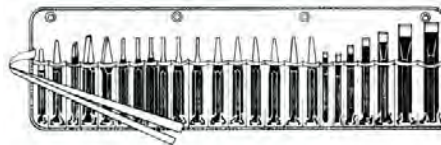

CHISELS:		PUNCHES:	
CAPE:	1/4"	CENTER:	5/32"
COLD:	1/4" 5/16" 3/8" 1/2" 5/8" 3/4" 7/8"		1/4" 3/32" 1/8" 5/32" 3/16" 1/4" 5/16"
		SOLID:	1/16" 1/8" 5/32" 3/16" 1/4" 5/16"
DIAMOND POINT:	1/4"		
HALF NOSE ROUND:	3/16"		

STOCK NO. MAY61050

#### 4 PIECE LINE-UP PUNCH KIT



LINE-UP PUNCHES:  
1/8"  
5/32"  
3/16"  
1/4"

STOCK NO. MAY62235

#### 6 PIECE PUNCH AND CHISEL KIT



CHISELS:		PUNCHES:	
COLD:	1/2" 5/8"	CENTER:	3/16" 1/8"
		SOLID:	3/16" 3/16"

STOCK NO. MAY61005

#### 5 PIECE CENTER PUNCH SET

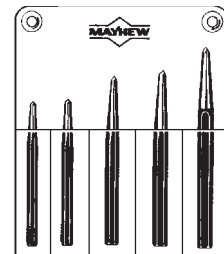

CENTER PUNCHES:	BODY SIZE	POINT	OVERALL LENGTH
	1/4	3/32	4"
	5/16	5/32	4-1/2"
	3/8	3/16	5"
	1/2	5/16	6"
	5/8	3/8	6-1/4"

STOCK NO. MAY62214



**SPECIAL PURPOSE FORGED BARS AND TOOLS**

**PINCH POINT CROWBARS**



USED TO PRY AND MOVE HEAVY OBJECTS. HIGH CARBON STEEL. SMOOTH TAPER. ROLL FORGED.

STOCK NO.	NET WEIGHT	STOCK SIZE	LENGTH
02101	6 LBS.	7/8	36"
02102	10 LBS.	1"	48"
SHV80	12 LBS.	1-1/8	51"
WAR02106	18 LBS.	1-1/4	60"
SHV81	22 LBS.	1-1/2	66"

**STRIPPING BARS WITH CLAW**



USED TO STRIP CONCRETE FORMS AFTER THE CONCRETE HAS SET. HIGH CARBON STEEL.

STOCK NO.	NET WEIGHT	STOCK SIZE	LENGTH
WAR02501	8 LBS.	7/8	42"
02502	12 LBS.	1"	48"

**SINGLE-END NAIL PULLER**



MADE FROM HIGHEST QUALITY STEEL. THIS "CAT'S PAW" TYPE PULLER WILL EASILY HANDLE A 30 PENNY NAIL. FULLY FORGED AND HEAT-TREATED.

STOCK NO.	STOCK SIZE	OVERALL LENGTH
END21	5/8"	10"

**3-PIECE LADY FOOT PRY BAR SET**



SET INCLUDES BODY SIZES 7/16, 9/16 AND 11/16 (12", 16" AND 21" OVERALL LENGTHS).

STOCK NO. MAY60150

**UTILITY BAR**



1/4 x 1-3/8 STOCK. 15" LENGTH.

STOCK NO. VBB215

**CARPENTERS WRECKING BARS**



HIGH CARBON HEX STEEL.

STOCK NO.	STOCK	LENGTH
WAR02802	5/8"	18"
WAR02803	3/4"	24"
WAR02804	3/4"	30"
WAR02805	3/4"	36"

**PRY BAR**



MADE FROM THE HIGHEST QUALITY TOOL STEEL. COMPOUND LEVERAGE. 5/8" STOCK, 12" LENGTH.

STOCK NO. END13

**MASON CHISEL**

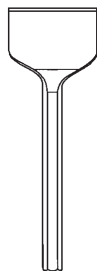

DESIGNED FOR CUTTING BRICK, CEMENT BLOCK, TRIMMING OFF EXCESS MORTAR, ETC. EXCELLENT FOR RAKING OUT JOINTS. FORGED AND HEAT-TREATED FROM THE FINEST HIGH CARBON TOOL STEEL. 2-1/2" CUP POINT.

STOCK NO.	STOCK SIZE	OVERALL LENGTH
ENB21	3/4"	7-1/2"

**DIE SETTERS BAR**



A PRACTICAL SHOP TOOL FOR QUICK SEPARATION OF PUNCH AND DIE HOLDER. 5/8" X 18" LONG.

STOCK NO. DTKL507035

**SCREW DRIVER TYPE PRY BAR**



STOCK NO.	BODY SIZE	OVERALL LENGTH
40110	3/8"	7"
40111	3/8"	12"
40112	1/2"	18"
MAY40109	1/2"	24"

**3 PIECE SCREWDRIVER-TYPE PRY BAR SET**

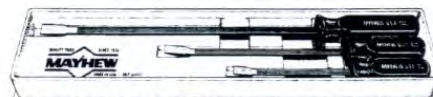

CURVED BLADE LENGTHS INCLUDE 7", 12" AND 18" (12", 17" AND 25-1/4" OVERALL LENGTHS).

STOCK NO. MAY61350

**TAMPER-TOP POST HOLE DIGGER ("SPUDBAR")**



USED FOR DIGGING POST HOLES AND TAMPING EARTH. ONE-PIECE HIGH CARBON STEEL. 1" STOCK, 69" LENGTH. 17 LBS.

STOCK NO. WAR02701  
SHV79

**STRAIGHT RIPPING CHISEL**



HEAT-TREATED. 3/4" STOCK, 18" LENGTH. 2 LBS.

STOCK NO. MAY41200

**PRY BARS**



USED FOR LINING UP HOLES AND FOR PRYING WORK, SUCH AS TIGHTENING BELTS IN AUTO REPAIR WORK, ETC. MADE FROM TAPERED HIGH CARBON, HEXAGONAL STEEL. HOT FORGED AND HEAT-TREATED. TAPERED END MAKES IT IDEAL FOR USE IN HOLE ALIGNMENT.

STOCK NO.	STOCK	LENGTH
WAR02707	1/2"	13"
WAR02708	5/8"	18"
WAR02709	3/4"	24"

**CLAY PICK**



HIGH CARBON STEEL. HEAT-TREATED. NO. 6 EYE. CHISEL AND POINT. SLIP-ON HANDLE REQUIRED (SEE BELOW FOR HANDLE).

STOCK NO.	NET WEIGHT	LENGTH
HAM246	LBS. 23"	

**MATTOCKS**

MADE OF HIGH CARBON STEEL. HEAT-TREATED. SLIP-ON TYPE HANDLE REQUIRED.



5# CUTTER MATTOCK. 15-3/4" LENGTH. NO. 6 EYE (SEE BELOW FOR HANDLE).

STOCK NO. HAM25



5# PICK MATTOCK. 19" LENGTH. NO. 6 EYE.

STOCK NO. HAM26



SLIP-ON HANDLE FOR THE ABOVE TOOLS. SELECT HARDWOOD, STANDARD #6 EYE. 36".  
STOCK NO. OPLE28836

## C-CLAMPS & MISCELLANEOUS CLAMPS

### SUPER JUNIOR CLAMPS

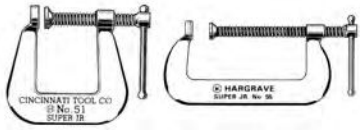

STEEL SCREWS ARE PLATED FOR LONGER LIFE. SUPER JUNIOR CLAMPS GIVE MORE STRENGTH, HAVE LONGER LIFE AND ARE A GREATER VALUE FOR ALL CLASSES OF WORK.

STOCK NO.	CLAMP NO.	OPENING	DEPTH*	TEST LOAD (LBS.)
21311	50	1"	1"	500
21312	51	1"	1-1/2"	500
<b>WAR21313</b>	52	1-1/4"	1-1/4"	800
<b>WAR21314</b>	53	1-1/2"	1-1/2"	850
<b>WAR21315</b>	54	2"	1-1/4"	875
<b>WAR21316</b>	55	3"	1-3/8"	1100
<b>WAR21307</b>	56	2-1/2"	2-1/2"	850

\*DEPTH IS FROM CENTER OF SCREW TO FRAME

### STANDARD CARRIAGE CLAMPS



#### NO. 540

FRAMES MADE FROM HIGH-STRENGTH DUCTILE IRON CASTINGS. SUPERIOR DESIGN PROVIDES SLIDING PIN (VISE-TYPE) HANDLE, SINGLE "ACME" THREAD SCREW AND OSCILLATING BALL AND SOCKET TIP. FRAME SHAPED FOR GREATEST STRENGTH FOR WEIGHT.

STOCK NO.	OPENING	DEPTH	SCREW DIA.	TEST LOAD (LBS.)
22001	2-1/2"	1-3/4"	1/2"	1100
<b>WAR22002</b>	3"	1-7/8"	1/2"	1800
<b>JMCM40</b>	4"	3-1/4"	5/8"	1200
22004	5"	2-1/2"	5/8"	2250
<b>JMCM60</b>	6"	3-1/2"	5/8"	1200
<b>JMCM80</b>	8"	4"	3/4"	1200
<b>WAR22007</b>	10"	3-5/8"	7/8"	2850
22008	12"	3-5/8"	7/8"	2850
22009	14"	3-3/4"	7/8"	2850

ADDITIONAL ITEMS AVAILABLE UPON REQUEST

### DEEP GENERAL PURPOSE BODY CLAMPS NO. 400

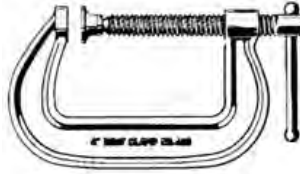

STEEL FRAME, DROP FORGED AND HEAT-TREATED FOR MAXIMUM STRENGTH. SPECIALLY MANUFACTURED SCREW PREVENTS BENDING AND BATTERING OF THREADS. SLIDING PIN HANDLE (VISE TYPE) AND BALL & SOCKET TIP.

STOCK NO.	CLAMP NO.	MAX. OPEN.	DEPTH	SCREW DIA.	TEST LOAD (LBS.)	
	CDF402	402	2"	2"	1/2"	3500
<b>JMCDF403</b>	403	3"	2-3/8"	1/2"	3500	
<b>JMCDF404</b>	404	4"	2-3/4"	5/8"	6200	
<b>JMCDF406</b>	406	6"	3-5/8"	3/4"	6900	
<b>JMCDF408</b>	408	8"	4-1/2"	7/8"	6900	
<b>JMCDF410</b>	410	10"	5-3/8"	7/8"	8000	
<b>JMCDF412</b>	412	12"	5-3/4"	7/8"	9300	

### SPRING CLAMPS



HEAVY GAGE STEEL SHAPED TO PROVIDE EASY HAND GRIP. PLATED FINISH HIGH GRADE TEMPERED STEEL SPRING HOLDS FIRMLY WITHOUT MARRING FINISH. CAN BE APPLIED OR REMOVED INSTANTLY.

STOCK NO.	CLAMP NO.	MAX. OPENING	LENGTH
<b>WAR14904</b>	1	1"	4"
<b>WAR14905</b>	2	2"	6"
<b>WAR14906</b>	3	3"	9"

A COMPUTER SALESMAN DIES AND MEETS ST. PETER AT THE PEARLY GATES. ST. PETER TELLS THE SALESMAN THAT HE CAN CHOOSE BETWEEN HEAVEN AND HELL. FIRST HE SHOWS THE MAN HEAVEN, WEHRE PEOPELE IN WHITE ROBES PLAY HARPS AND FLOAT AROUND. "DULL," SAYS THE SALESMAN  
 NEXT, ST. PETER SHOWS HIM HELL: TOGA PARTIES, GOOD FOOD AND WINE, AND PEOPLE LOOKING AS THOUGH THEY'RE HAVING A FINE TIME. "I'LL TAKE HELL," HE SAYS.  
 HE ENTERS THE GATES OF HELL AND IS IMMEDIATELY SET UPON BY A DOZEN DEMONS, WHO POKE HIME WITH PITCHFORKS. "HEY," THE SALESMAN DEMANDS AS SATAN WALKS PAST, "WHAT HAPPENED TO THE PARTY I SAW GOING ON?"  
 "AH," SATAN REPLIES, "YOU MUST HAVE SEEN OUR DEMO."

### MISCELLANEOUS CLAMPS (CONT.)

#### CLAMP FIXTURE FOR 3/4" PIPE



FITS 3/4" PIPE. EASY TO ASSEMBLE ON ANY LENGTH 3/4" PIPE. CASTINGS ARE MALLEABLE AND/OR DUCTILE IRON; POWDER COATED ORANGE AND BLACK BAKED-ENAMEL FINISH. THE SCREW IS 5/8" DIAMETER STEEL WITH SPECIAL, SMOOTHLY CUT ACME THREADS; HARDENED STEEL THRUST BEARING IN SLIDING HEAD PREVENTS WEAR AT POINT OF SCREW; CRANK-TYPE HANDLE. MULTIPLE-DISC-CLUTCHES ARE PLATED HARDENED STEEL; 4 PIECES PER SET. CLAMPING FACES ARE APPROXIMATELY 1-3/4" SQUARE. A COIL SPRING "STOP" IS INCLUDED WITH EACH CLAMP FIXTURE. MOUNTS ON ANY LENGTH 3/4" BLACK PIPE WITH BOTH ENDS THREADED. (PIPE NOT INCLUDED) IDEAL FOR METALWORKING, WOODWORKING, AND FRAME ASSEMBLY.

STOCK NO.	SCREW DIA.
<b>PONY50</b>	5/8

#### 2-1/2" DEEP REACH CLAMP & SPREADER



FITS 3/4" PIPE. EASY TO ASSEMBLE ON ANY LENGTH PIPE. CASTINGS ARE MALLEABLE AND/OR DUCTILE IRON; POWDER COATED ORANGE AND BLACK BAKED-ENAMEL FINISH. THE SCREW IS 5/8" DIAMETER STEEL WITH SPECIAL, SMOOTHLY CUT ACME THREADS; WING-NUT HANDLE. MULTIPLE-DISC-CLUTCHES ARE PLATED HARDENED STEEL; 4 PIECES PER SET. SWIVEL IS 1-1/4" DIAMETER WITH STEEL INTERNAL LOCKWASHERS FOR POSITIVE "STAY-ON" POWER. A COIL SPRING "STOP" IS INCLUDED WITH EACH CLAMP FIXTURE. MOUNTS ON ANY LENGTH 3/4" BLACK PIPE WITH BOTH ENDS THREADED. (PIPE NOT INCLUDED) ALL ADJUSTMENTS ARE MADE FROM ONE END. IDEAL FOR COUNTERTOPS, CABINETS, INSIDE "TIGHT QUARTERS" WORK AND A VARIETY OF OTHER APPLICATIONS. THE HEADS CAN ALSO BE REVERSED TO "SPREAD" WORK.

STOCK NO.	SCREW DIA.
<b>PONY56</b>	5/8

**LET OUR INVENTORY SERVE AS YOUR INVENTORY**



**MISCELLANEOUS CLAMPS**

**REGULAR DUTY "I" BAR CLAMPS NO. 640**



A RAPID-ACTING POWERFUL CLAMP DESIGNED AND CONSTRUCTED FOR HARD EVERYDAY PRODUCTION WORK. PATENTED LOCKING DEVICE FOR A POSITIVE STOP. CANNOT BIND OR SLIP AND RELEASES READILY. BAR IS SHAPED TO PROVIDE GREAT STRENGTH AND WILL NOT MAR WORKING SURFACES. HEAVY-TEMPERED STEEL PAWL. CLAMPING SURFACE IS 1-13/16 DEEP X 1-7/8 WIDE, SCREW DIAMETER IS 5/8 AND BAR DIMENSION IS 7/16 x 1-1/2 x 5/32 (H.D. BAR CLAMPS ARE ALSO AVAIL.).

STOCK NO.	OPENING	WEIGHT
21801	2 FT.	7 LBS.
21802	2-1/2 FT.	7-1/2 LBS.
21803	3 FT.	8 LBS.
21804	4 FT.	9-1/2 LBS.
21805	5 FT.	10-1/2 LBS.
21806	6 FT.	12 LBS.

**QUICK-GRIP  
WELDING CLAMP**



ONE-HANDED PISTOL-GRIP OPERATION. IDEAL FOR QUICK TACKING. HEAT-TREATED CARBON STEEL JAWS. SPATTER-RESISTANT COPPER-PLATED PADS. HORIZONTAL AND VERTICAL GROOVES IN JAWS ALLOW EASY CLAMPING OF ROUND STOCK.

STOCK NO.	JAW ADJUSTMENT	THROAT DEPTH
<b>VG00506</b>	0-6" - 0-150MM	3-1/4 - 82.5MM
<b>VG00512</b>	0-12" - 0-300MM	3-1/4 - 82.5MM
<b>VG00518</b>	0-18" - 0-455MM	3-1/4 - 82.5MM
00524	0-24" - 0-605MM	3-1/4 - 82.5MM
00536	0-36" - 0-910MM	3-1/4 - 82.5MM

**SERVICE WITH A SMILE.**



**SLIDING ARM CLAMPS**



ALL FORGED HEAT-TREATED CLAMPS FROM BESSEY PROVIDE INSTANT CLAMPING AT ANY OPENING. NO WASTED SET-UP TIME. ONE BESSEY COVERS THE RANGE OF TWO OR MORE ORDINARY CLAMPS. ALL BESSEYS HAVE DEEP THROATS FOR GREATER REACH. CLAMPS DO NOT TWIST OR WALK, AND SCREWS DO NOT BEND. CLAMP FASTER WITH BESSEY.

**2400 SERIES REGULAR-DUTY**



1.4 TONS (2800 LBS.) OF CLAMPING PRESSURE. USE FOR REGULAR WORK (I.E. UP TO 1/2" PLATE WORK, ETC.).

STOCK NO.	NOMINAL OPENING	NOMINAL THROAT DEPTH
<b>JM2400S12</b>	12"	5-1/2"
<b>JM2400S20</b>	20"	5-1/2"
<b>JMS400S40</b>	40"	5-1/2"

**MULTI-GRIP WELDING CLAMP**



SERRATED FORGED STEEL JAWS. HARDENED STEEL RAILS. CLAMPING PRESSURE NUT/SCREW ADJUSTMENT. 2" NOM. OPENING. 1-3/4" THROAT DEPTH. 330 LB. PRESSURE.

STOCK NO. **JMSG2**

**4800 SERIES HEAVY-DUTY**



2.4 TONS (4800 LBS.) OF CLAMPING PRESSURE. USE FOR HEAVY WORK (I.E. 1/2" TO 3/4" PLATE WORK, ETC.).

STOCK NO.	NOMINAL OPENING	NOMINAL THROAT DEPTH
<b>JM4800S12</b>	12"	7"
<b>JM4800S18</b>	18"	7"
<b>4800S40</b>	40"	7"

**WELDERS' ANGLE CLAMP**



SELF-CENTERING FIXTURE VISE THAT HOLDS THE WORKPIECE AT 90 DEGREES FOR WELDING (T-JOINTS, ETC.). CAST IRON. TOTAL CAPACITY 7". 1-1/2" JAW HEIGHT; 4" JAW LENGTH. 2-1/2" PASSAGE FOR T-JOINTS.

STOCK NO. **JMWSM9**

**ADJUSTABLE CLAMPS**



(SQ SERIES) ONE-PIECE PAD/SCREW ASSEMBLY. VIRTUALLY UNLIMITED RANGE OF APPLICATIONS. POSITIVE GRIP, WITH QUICK TIGHTENING AND RELEASE.

STOCK NO.	NOMINAL OPENING	NOMINAL THROAT DEPTH	NOMINAL CLAMPING PRESSURE
<b>JMSQ4</b>	4"	4-3/4"	1330 LBS.
<b>JMSQ8</b>	8"	5-1/2"	2660 LBS.
<b>JMSQ12</b>	12"	5-1/2"	2660 LBS.
<b>JMSQ20</b>	20"	5-1/2"	2660 LBS.

**POWER-GRIP CLAMP**



WITH ALUMINUM HANDLE. SINGLE-HAND CLAMPING LEVER. PROFILED RAIL FROM SPRING-TEMPERED STEEL FOR STRENGTH. QUICK-RELEASE LEVER FOR SLIDING ARM. 4" NOMINAL THROAT DEPTH. 12" NOMINAL OPENING. 200 LB. CLAMPING PRESSURE WITH LEVER. 1,000 LB. CLAMPING PRESSURE WITH HANDLE.

STOCK NO. **JMPG12**

### HOLD-DOWN CLAMPING DEVICES AND TABLE CLAMPING FASTENERS

#### TOGGLE CLAMPS

##### HORIZONTAL HANDLE - FLANGED BASE



HOLDING CAPACITY 200 LBS. NEOPRENE-TIPPED SPINDLE ASSEMBLY. HANDLE MOVES 60°. BAR MOVES 85°. HOLE PATTERN 1-1/16" x 7/8". OVERALL LENGTH 5-7/16".

STOCK NO. MSIGH201B



HOLDING CAPACITY 500 LBS. NEOPRENE-TIPPED SPINDLE ASSEMBLY. HANDLE MOVES 65°. BAR MOVES 90°. HOLE PATTERN 1" x 7/8". OVERALL LENGTH 6-19/32".

STOCK NO. MSIGH225D



HOLDING CAPACITY 750 LBS. NEOPRENE-TIPPED SPINDLE ASSEMBLY. HANDLE MOVES 50°. BAR MOVES 85°. HOLE PATTERN 1-5/8" x 1-5/8". OVERALL LENGTH 10-3/8".

STOCK NO. MSIGH20235

##### VERTICAL HANDLE - FLANGED BASE



HOLDING CAPACITY 200 LBS. NEOPRENE-TIPPED SPINDLE ASSEMBLY. HANDLE MOVES 60°. BAR MOVES 100°. HOLE PATTERN 1/2" x 1-1/16". OVERALL HEIGHT 3-3/4".

STOCK NO. MSIGH12050

VERTICAL TOGGLE CLAMPS CONTINUED  
NEXT COLUMN



STOCK NO. MSIGH12265

##### PUSH/PULL STYLE - INTERNAL THREADS



HOLDING CAPACITY 300 LBS. PLUNGER TRAVEL 1-1/4". PLUNGER LOCKS IN EXTENDED OR RETRACTED POSITION. NEOPRENE-TIPPED SPINDLE ASSEMBLY. HOLE PATTERN 1-3/8" x 1-5/8". OVERALL LENGTH 5-7/16".

STOCK NO. MSIGH302F



HOLDING CAPACITY 500 LBS. PLUNGER TRAVEL 1-3/16". HEAVY-DUTY DUCTILE IRON BASE LOCKS IN EXTENDED OR RETRACTED POSITION (IDEAL FOR PIN LOCATING GAUGES). NEOPRENE-TIPPED SPINDLE ASSEMBLY. HOLE PATTERN 1-3/8" x 1-5/8". OVERALL LENGTH 4-15/16".

STOCK NO. MSIGH304C

##### LATCHING STYLE - FLANGED BASE - T-HANDLE



HOLDING CAPACITY 700 LBS. SUPPLIED WITH LATCH PLATES. NEOPRENE-DIPPED HAND GRIP. ADJUSTABLE OVERALL LENGTH. HOLE PATTERN 3/4" x. ADJUSTABLE BAR LENGTH.

STOCK NO. MSIGH431

ADDITIONAL TOGGLE CLAMP MODELS  
AVAILABLE UPON REQUEST



#### HOLD-DOWN CLAMP



RATCHET-ACTION MECHANISM IS FAST AND SECURE. IDEAL FOR MILLING OR DRILLING ON MACHINES EQUIPPED WITH "T" SLOTS. VIBRATION PROOF. QUICK-RELEASE BUTTON. 10" NOMINAL OPENING. 4-1/2" NOMINAL THROAT DEPTH. 2220 LBS. CLAMPING PRESSURE.

STOCK NO. JM2400HD10

#### WELDERS' MAGNETIC SQUARES



USE THE MAGNETIC SQUARE TO HOLD SHEET METAL, PIPES, RODS OR OTHER COMPONENTS EXACTLY IN POSITION WHILE WELDING, BRAZING AND SOLDERING.

OPEN CONSTRUCTION (MAGNET EXPOSED)  
STOCK NO. JMWMS1

ENCLOSED CONSTRUCTION (MAGNET CONCEALED)  
STOCK NO. JMWMS2

#### TABLE CLAMPING FASTENERS

##### T-SLOT NUTS



STOCK NO.

##### T-SLOT BOLTS

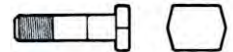

STOCK NO.

SIZE

TABLE SLOT

SIZE

N10	3/8-16	7/16	B020	3/8-16 x 1-1/2
N12	3/8-16	1/2	B021	3/8-16 x 2"
N14	3/8-16	9/16	B023	3/8-16 x 3"
N20	1/2-13	9/16	B025	3/8-16 x 4"
N22	1/2-13	5/8	B041	1/2-13 x 2"
N24	1/2-13	11/16	B043	1/2-13 x 3"
N30	5/8-11	11/16	B045	1/2-13 x 4"
N32	5/8-11	3/4	B047	1/2-13 x 5"
N34	5/8-11	13/16	B049	1/2-13 x 6"
TSN40	3/4-10	13/16	B061	5/8-11 x 2"
N42	3/4-10	7/8	B063	5/8-11 x 3"
N44	3/4-10	1"	B065	5/8-11 x 4"
			B067	5/8-11 x 5"
			B069	5/8-11 x 6"
			B082	3/4-10 x 3"
			B084	3/4-10 x 4"
			B086	3/4-10 x 5"
			B088	3/4-10 x 6"

#### FLANGE NUTS

STOCK NO.

SIZE

TSN61	1/2-13
TSN62	5/8-11
TSN63	3/4-10
TSN64	7/8-9
TSN65	1"-8
TSN66	1-1/4-7



# COLUMBIAN®

## VICES



### UTILITY VISES



EXCELLENT UTILITY VISES. HEAVY-DUTY STEEL FRONT JAW BEAM COVERS SCREW. EXTRA LARGE BACK JAW ANVIL AND ANVIL HORN. COLD ROLLED STEEL SCREW. HANDLE BALLS FORGED FROM HANDLE STOCK. REPLACEABLE MALLEABLE IRON NUT. REPLACEABLE COMPRESSED POWDERED METAL JAW FACES. PERMANENT PIPE JAWS, POSITIVE "TRI-GRIP" DESIGN. POSITIVE LOCKING SWIVEL BASE, SLIP HANDLE AND LOCK NUT. POLISHED JAWS AND ANVIL. BRIGHT RED FINISH. SCREW, HANDLE AND LOCK NUT BRIGHT ZINC PLATED.

STOCK NO.	JAW WIDTH	JAW OPEN.	PIPE CAPACITY	WEIGHT (LBS.)
WAR11126	4-1/2	4"	1/8 - 2"	19
WAR11121*	5"	5-3/4	1/8 - 2"	28
WAR11127	5-1/2	5"	1/8 - 2-1/2	29
WAR191	6-1/4	6"	1/8 - 3"	63

\*SUBJECT TO AVAILABILITY

### MECHANICS VISE



HEAVY DUTY 30,000 PSI CASTING FOR LONG LIFE AND ADDED STRENGTH. SWIVEL BASE ROTATES 360 DEGREES. REPLACEABLE HARDENED STEEL TOP AND PIPE JAWS. IDEAL FOR PROFESSIONAL MECHANICS.

STOCK NO.	JAW WTH.	JAW OPEN	THROAT DEPTH	PIPE JAW CAPACITY	WT. LBS.
WAR21300	4"	4-1/2	3-7/16	1/4-2"	37
WAR21400	5"	5-1/4	3-3/4	1/4-2-1/2	50
WAR21500	6"	5-3/4	4-1/8	1/4-3-1/2	64

**OUR STAFF IS ALWAYS AT YOUR SERVICE. CALL TO PLACE AN ORDER, AND REMEMBER TO HAVE THIS VALUABLE CATALOG NEARBY!**

### STATIONARY BASE MACHINISTS' VISES

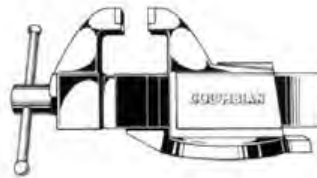

FLAT BASE MAKES IT UNNECESSARY TO CUT BENCH. MALLEABLE OR DUCTILE IRON CASTINGS GUARANTEED. STEEL HANDLE BALLS FORGED FROM HANDLE STOCK. SELF-LUBRICATING GRAPHITE BRONZE BEARING. REMOVABLE HARDENED TOOL STEEL JAW FACES.

STOCK NO.	JAW WIDTH	JAW OPENING	THROAT DEPTH	WEIGHT (LBS.)
10101	3"	4"	3"	21
10102	3-1/2	5"	3-1/4	30
10103	4"	6"	3-5/8	39
10104	4-1/2	7"	4-1/8	51
10105	5"	8"	4-1/4	68
10106	6"	10"	4-3/8	96

### SWIVEL BASE MACHINISTS' VISES

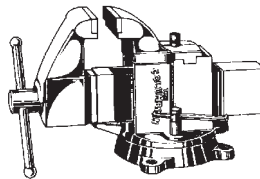

SWIVELS FULL 360 DEG. GEARED BOLT AND BASE PLATE AFFORD POSITIVE LOCK AGAINST SLIPPAGE. MALLEABLE OR DUCTILE IRON CASTING GUARANTEED. STEEL HANDLE BALLS FORGED FROM HANDLE STOCK. SELF-LUBRICATING GRAPHITE BRONZE BEARING. REPLACEABLE HARDENED TOOL STEEL "T" JAW FACES, SECURELY FASTENED WITH DRIVE PINS. NO HOLES IN GRIPPING FACE.

STOCK NO.	JAW WIDTH	JAW OPENING	THROAT DEPTH	WEIGHT (LBS.)
10201	3"	4"	3"	26
10202	3-1/2	5"	3-1/4	37
WAR10203	4"	6"	3-5/8	46
10204	4-1/2	7"	4-1/8	59
WAR10205	5"	8"	4-1/4	79
10206	6"	10"	4-3/8	111

### ECONOMY DRILL PRESS VISES



THE AXIAL SLEEVE AND MOVABLE JAW ARE CAST IN ONE SINGLE PIECE.

STOCK NO.	JAW WTH.	JAW DPTH.	JAW OPN.	STYLE	SCREW DIA.	WT. LBS.
JET365523	3"	1"	3"	PLAIN	5/8	7
JET365524	4"	1-1/8	4"	PLAIN	5/8	9
JET365525	5"	2-1/8	5"	PLAIN	7/8	23

### DRILL PRESS AND MILLING MACHINE VISES

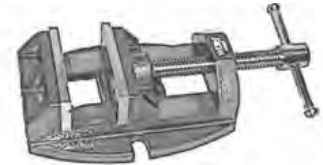

ELIMINATES NEED FOR SPECIAL AND EXPENSIVE JIGS AND FIXTURES. PROVIDES MAXIMUM CLAMPING AND HOLDING POWER. COLD ROLLED STEEL SCREW. 4 KEY SLOTS PROVIDE PRECISION MOUNTING.

STOCK NO.	JAW WTH.	JAW DPTH.	JAW OPN.
10713	3-1/2	1-7/8	4-1/2
WAR63240	5"	2"	5"
10725	5"	2"	6"

### ANGLE VISE



FOR DRILL PRESS, MILLING MACHINE, GRINDER AND BENCH WORK. MAKES QUICK, ACCURATE SETUPS WITHOUT CLAMPS OR WEDGES. ADJUSTS TO ANY ANGLE, FROM 0 TO 90 DEGREES. CAN BE USED AS ORDINARY VISE WHEN HORIZONTAL. ACCURATELY GRADUATED FOR ALL ANGLES. GROOVED STEEL JAW FOR HOLDING ROUND OR TAPERED PIECES. STEEL, ADJUSTABLE SUPPORT SCREWS. 9" OVERALL.

STOCK NO.	JAW WTH.	JAW DPTH.	JAW OPEN.	JAW DIA.	SCREW DIA.	WEIGHT
WAR12850	2-1/2"	1-1/2"	2-1/2"	1/2"		8 LBS.

### COPPER JAW CAPS



FIT SNUGLY OVER JAWS AND COVER. KNURLED STEEL FACES TO PREVENT MARRING OF SOFT MATERIALS. EASILY INSTALLED AND REMOVED.

STOCK NO.	JAW WIDTH
24403	3"
24404	3-1/2
24405	4"
24406	4-1/2
24407	5"
24408	6"

### FIBERGLASS LADDERS

#### FIBERGLASS STEPLADDERS

**TYPE 1A, 300 LB. RATING  
EXTRA HEAVY-DUTY INDUSTRIAL**



INSIDE SPREADER BRACES LOCATED INSIDE THE RAILS FOR PROTECTION DURING TRANSIT AND STORAGE. REINFORCED BACK BRACES ARE STRONGER THAN STANDARD ANGLE STOCK, WITHOUT ADDING WEIGHT. MOLDED TOP WITH RECESSED TOOL TRAY. DOUBLE GUSSETED BOTTOM STEP.

STOCK NO.	LENGTH	COLOR
GB202204	4'	YELLOW
GB202205	5'	YELLOW
GB202206	6'	YELLOW
GB223206*	6'	YELLOW
GB202208	8'	YELLOW
GB203210*	10'	ORANGE
GB203212*	12'	ORANGE

\*SUPER EXTRA HEAVY-DUTY. 375 LB. RATING

**TYPE 1A, 300 LB. RATING  
EXTRA HEAVY-DUTY INDUSTRIAL**



EXTRUDED HEAVY-GAUGE ALUMINUM TOP WITH TOOL TRAY AND HOLES. INSIDE SPREADER BRACES LOCATED INSIDE THE RAILS FOR PROTECTION DURING TRANSIT AND STORAGE. HEAVY DUTY STEP ATTACHMENT. SLIP RESISTANT SHOES HAVE SERRATED RUBBER TREADS FOR EXCELLENT TRACTION ON MANY SURFACES.

STOCK NO.	LENGTH	COLOR
GB211206	6'	YELLOW
GB211208	8'	YELLOW

#### FIBERGLASS STEPLADDERS

**TYPE 1, 250 LB. RATING  
HEAVY-DUTY INDUSTRIAL**



DOUBLE GUSSETED BOTTOM STEP PROVIDES GREATER STRENGTH THAN FLAT BRACES. HEAVY DUTY STEP ATTACHMENT, EACH STEP IS ATTACHED BY 6 STEEL RIVETS. PINCH-FREE SPREADER BRACES. MOLDED TOP WITH RECESSED TOOL TRAY MADE FROM NON-CONDUCTIVE MATERIAL RESISTS DENTING OR BENDING.

STOCK NO.	LENGTH	COLOR
GB208204	4'	GRAY
GB208206	6'	GRAY
GB208208	8'	GRAY

#### FIBERGLASS EXTENSION LADDERS

**TYPE 1A, 300 LB. RATING  
EXTRA HEAVY-DUTY INDUSTRIAL**



CAST ALUMINUM RUNG LOCK, SPRING-ASSISTED MECHANISM HAS POLYCARBONATE FLIPPERS FOR LONGER LIFE AND A QUIET SLIDING ACTION OVER RUNGS. DIRECT RUNG CONNECTION. FULL-LENGTH INTERLOCKING RAILS PROVIDE SMOOTH SLIDING ACTION AND AN EXTRA MARGIN OF SECURITY. OUTSIDE SLIDE GUIDES, TWO HEAVY DUTY SLIDE GUIDES ARE SECURED TO THE TOP OF THE BASE SECTION WITH 4 RIVETS FOR ADDED STRENGTH.

STOCK NO.	LENGTH	COLOR
606216*	16'	YELLOW
GB606220	20'	YELLOW
GB606224	24'	YELLOW
606228	28'	YELLOW
GB606232	32'	YELLOW
GB606236	36'	YELLOW
606240	40'	YELLOW

\*ROPE AND PULLEY NOT INCLUDED

#### FIBERGLASS DOUBLE STEPLADDERS



**TYPE 1, 250 LB.  
HEAVY-DUTY**

**TYPE 1A, 300 LB.  
EXTRA HEAVY-DUTY**

PINCH-FREE SPREADER BRACES WITH DOUBLE-RIVET CENTER HINGE PROTECTS USER FROM PINCHED FINGERS. HEAVY DUTY TOP HINGE USES 10 STEEL RIVETS ON EACH SIDE FOR LONG-LASTING DURABILITY. HEAVY DUTY STEP ATTACHMENT. SLIP RESISTANT SHOES.

STOCK NO.	LENGTH	COLOR
GB206204	4'	YELLOW
GB209206*	6'	GRAY
GB206206	6'	YELLOW
GB206208	8'	YELLOW
GB206210	10'	YELLOW
GB206212	12'	YELLOW
GB204214	14'	RED

\*TYPE 1 (ALL OTHERS ARE TYPE 1A)

#### FIBERGLASS EXTENSION LADDERS

**TYPE 1-AA, 375 LB. RATING  
EXTRA HEAVY-DUTY INDUSTRIAL**



HEAVY CAST ALUMINUM SHOE ASSEMBLY MADE OF THICK RUBBER TREADS AND CONVENIENT FLIP DOWN SPIKES PROVIDE A STRONG FOUNDATION. RIVETED RUNG PLATES. FULL-LENGTH EXTRA HEAVY DUTY INTERLOCKING RAILS PROVIDES SMOOTH SLIDING ACTION AND AN EXTRA MARGIN OF SECURITY. OUTSIDE SLIDE GUIDES ARE SECURED TO THE TOP OF THE BASE SECTION WITH 4 RIVETS PER GUIDE FOR ADDED STRENGTH.

STOCK NO.	LENGTH	COLOR
620216*	16'	RED
620220	20'	RED
GB620224	24'	RED
GB620228	28'	RED

\*ROPE AND PULLEY NOT INCLUDED

HERE, THE CUSTOMER ALWAYS COMES FIRST.

**FIBERGLASS & ALUMINUM LADDERS**

**FIBERGLASS SINGLE LADDERS**

**TYPE 1A, 300 LB. RATING  
EXTRA HEAVY-DUTY INDUSTRIAL**



FEATURES DEEPLY SERRATED FLAT RUNGS AND COMBINATION ALUMINUM RAIL SHIELD BRACKET AND SHOE WITH RUBBER FOOT PAD AND SPUR PLATE. NON-CONDUCTIVE. ORANGE COLOR CODE

**STOCK NO.      LENGTH**

<b>GB605208</b>	8'
<b>GB605210</b>	10'
<b>GB605212</b>	12'
<b>GB605214</b>	14'
<b>GB605216</b>	16'

**BRIGHT IDEAS**

Q: HOW MANY CAR SALESMEN DOES IT TAKE TO CHANGE A LIGHT BULB?

A: I'M JUST GOING TO WORK THIS OUT ON MY CALCULATOR, AND I THINK YOU'RE GOING TO BE PLEASANTLY SURPRISED.

Q: HOW MANY POLITICIANS DOES IT TAKE TO CHANGE A LIGHT BULB?

A: FIVE--ONE TO CHANGE IT AND FOUR TO DENY IT.

Q: HOW MANY BULLIES DOES IT TAKE TO CHANGE A LIGHT BULB?

A: FOUR. DO YOU HAVE PROBLEM WITH THAT?

Q: HOW MANY BUREAUCRATS DOES IT TAKE TO CHANGE A LIGHT BULB?

A: TWO. ONE TO ASSURE US THAT EVERYTHING POSSIBLE IS BEING DONE WHILE THE OTHER SCREWS THE BULB INTO A WATER FAUCET.

Q: HOW MANY UNEMPLOYED ACTORS DOES IT TAKE TO CHANGE A LIGHT BULB?

A: 100. ONE TO CHANGE IT, AND 99 TO STAND AROUND AND SAY, "HEY, I COULD'VE DONE THAT!"

Q: HOW MANY ECONOMISTS DOES IT TAKE TO CHANGE A LIGHT BULB?

A: HOW MANY DID IT TAKE THIS TIME LAST YEAR?

Q: HOW MANY REAL-ESTATE AGENTS DOES IT TAKE TO CHANGE A LIGHT BULB?

A: TEN. BUT WE'LL EXCEPT EIGHT.

Q: HOW MANY LIBERATED WOMEN DOES IT TAKE TO CHANGE A LIGHT BULB?

A: FIVE! ONE TO TURN IT, AND FOUR TO FORM A SUPPORT GROUP.

**FIBERGLASS TWIN STEP STOOL**

**TYPE 1A, 300 LB. RATING  
EXTRA HEAVY-DUTY INDUSTRIAL**



NON-CONDUCTIVE SIDE RAILS, BLACK END CAPS, HEAVY-GAUGE STRAP HINGE, "PINCH PROOF" STEEL SPREADERS, 3" TREADED STEPS, COMBINATION RAIL END SHIELD AND SHOE WITH RUBBER FOOT PAD. ALSO SERVES AS A DOUBLE STEP STOOL (ONE PERSON PER SIDE). 2' OVERALL HEIGHT.

**STOCK NO. GB206202**

**ALUMINUM STEPLADDERS**

**TYPE 1, 250 LB. RATING  
HEAVY-DUTY INDUSTRIAL**



MOLDED TOP WITH RECESSED TOOL TRAY. GUSSETED BACK BRACES FOR ADDED RIGIDITY. SLIP-RESISTANT SHOES HAVE SERRATED RUBBER TREADS FOR EXCELLENT TRACTION ON MANY SURFACES. PINCH-FREE SPREADER BRACES.

**STOCK NO.      LENGTH**

<b>GB208106</b>	6'
<b>GB208108</b>	8'

**ALUMINUM EXTENSION LADDERS**

**TYPE 1A, 300 LB. RATING  
EXTRA HEAVY-DUTY INDUSTRIAL**



HEAVY CAST ALUMINUM SHOE ASSEMBLY PROVIDES A STRONG FOUNDATION. HEAVY DUTY PULLEY AND ROPE DESIGNED TO PULL EASILY WITHOUT BINDING OR CHAFING. CAST ALUMINUM RUNG LOCK HAS POLYCARBONATE FLIPPERS FOR LONGER LIFE. FULL-LENGTH INTERLOCKING RAILS PROVIDES SMOOTH SLIDING ACTION. NYLON END CAPS ADD TREMENDOUS PROTECTION TO THIS HIGH IMPACT AREA WITHOUT ADDING WEIGHT.

**STOCK NO.      LENGTH**

<b>GB610116</b>	16'
<b>GB610120</b>	20'
<b>GB610124</b>	24'
610128	28'
610132	32'
<b>GB610140</b>	40'

**ADDITIONAL LADDERS  
AVAILABLE  
UPON REQUEST**

**OUR PRODUCTS MEET  
OSHA STANDARDS**



### HAND TRUCKS, MATERIAL-HANDLING ITEMS & ACCESSORIES

#### LOOP HANDLE (FLOW BACK) STEEL HAND TRUCKS 42" STACKING HEIGHT



STOCK NO.	LOAD CAPACITY	TIRE TYPE
MT40109	300 LBS.	SEMI-PNEUMATIC
MT40107	400 LBS.	SEMI-PNEUMATIC
MT40380	600 LBS.	PNEUMATIC
MT40178	750 LBS.	MOLD-ON RUBBER

BARREL HOOK FOR HAND TRUCK 40178. HOOKS ONTO TO BARREL LIP ALLOWING OPERATOR TO LIFT WITH EASE  
**STOCK NO. MT40184**



#### DUAL HANDLE STEEL HAND TRUCKS



42" STACKING HEIGHT

STOCK NO.	LOAD CAPACITY	TIRE TYPE
MT40132	400 LBS.	SEMI-PNEUMATIC
MT40135	800 LBS.	PNEUMATIC

#### REPLACEMENT 10" PNEUMATIC TIRE



**STOCK NO. MTR1395** (5/8" BORE SIZE)

#### ALUMINUM HAND TRUCKS 46" STACKING HEIGHT - 500 LB. LOAD CAPACITY

LOOP HANDLE

DUAL HANDLE

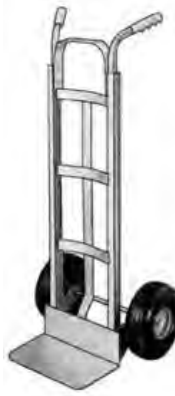
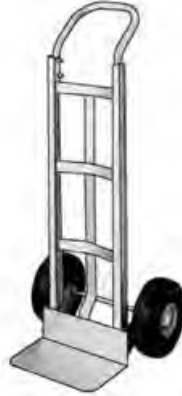

STOCK NO.	HANDLE TYPE	TIRE TYPE
MT45110	LOOP	PNEUMATIC
MT45122	DUAL	PNEUMATIC

#### WELDING CYLINDER TRUCKS



WELDING CYLINDER TRUCKS HAVE A 200 LB. LOAD CAPACITY, TWO TANK CYLINDER DIAMETER, ATTACHED TOOL BOX, NOSE PLATE WITH DIVIDER BAR, AND MEASUREMENT CAPACITIES OF 7-1/8" to 8-1/2" DIAMETER; 35" to 51" HIGH. SEMI-PNEUMATIC TIRES. OTHER SIZES, STYLES ARE AVAILABLE.

**STOCK NO. MT40142** (8" x 1.75" TIRE SIZE)  
**STOCK NO. MT40143** (10" x 1.75" TIRE SIZE)

**ADDITIONAL HAND TRUCKS AND ACCESSORIES AVAILABLE UPON REQUEST**

#### CONVERTIBLE HAND TRUCK



400 LB. VERTICAL LOAD CAPACITY, 500 LB. HORIZONTAL LOAD CAPACITY. LOOP HANDLE (FLOW BACK). 12" x 36" PLATFORM. WHEEL GUARDS. SEMI-PNEUMATIC TIRES. 17" OVERALL WIDTH.

**STOCK NO. MT40180**

#### DRUM CRADLES



HEAVY-DUTY 1-1/4" DIAMETER KNOCK DOWN STEEL TUBING CONSTRUCTION CARRIES 30 OR 55 GALLON DRUM. TIPPING HANDLE IS REMOVABLE. 800 LB. LOAD RATING. 23" WIDTH.

STATIONARY MODEL  
**STOCK NO. MT40157**



4-WHEEL MOBILE MODEL  
**STOCK NO. MT40158**  
 (PICTURED ABOVE)

2-WHEEL & 2-CASTER MOBILE MODEL  
**STOCK NO. MT40148SC**  
 (PICTURED ABOVE RIGHT)

#### MOBILE DRUM DOLLY



800 LB. LOAD CAPACITY. 55 GALLON DRUM SIZE CAPACITY. I.D. 24". RUBBER SWIVEL CASTERS MEASURE 3" x 1-1/4".

**STOCK NO. HT8337**

WHILE FORBIDDEN FRUIT IS SAID TO TASTE SWEETER, IT USUALLY SPOILS FASTER.  
 --ABIGAIL VAN BUREN

**HAND TRUCKS AND MATERIAL-HANDLING ITEMS**



**STEEL DRUM AND BARREL TRUCK**

DUAL-HANDLE STYLE. 1,000 LB. LOAD CAPACITY. 67" OVERALL HEIGHT. 28-1/2" OVERALL WIDTH. ADJUSTABLE BARREL HOOK. CAST-IRON WHEELS AND MOLD-ON RUBBER TIRES.

STOCK NO. MT40181

**STEEL APPLIANCE TRUCK**

WELDED STEEL APPLIANCE TRUCK WITH RATCHETING STRAP TIGHTENERS MOVE LARGE APPLIANCES. THE APPLIANCE TRUCK HAS FRAME PADDING TO PROTECT THE LOAD FROM BEING SCRATCHED BY THE HAND TRUCK.



STOCK NO. MT40188



**HAND TRUCK WITH STAIR CLIMBER**

600 LB. LOAD CAPACITY. LOOP (FLOW BACK) HANDLE. 42" STACKING HEIGHT. 23" OVERALL HEIGHT. 8" x 14" TOE PLATE. STAIR CLIMBER RODS AND ACCESSORY BRACKETS INCLUDED. PNEUMATIC TIRES.

STOCK NO. MT49112

**STEEL PLATFORM TRUCK**



24" x 48" DECK SIZE. 750 LB. LOAD CAPACITY. 9" PLATFORM HEIGHT FROM FLOOR. LOOP (FLOW BACK) HANDLE. 6" x 2" SOLID RUBBER TIRES.

STOCK NO. MT40124

**FOLD DOWN PLATFORM CART**



24" x 36" DECK SIZE. 660 LB. LOAD CAPACITY. 8" PLATFORM HEIGHT FROM FLOOR. LOOP HANDLE. NON SKID PLATFORM. VINYL PERIMETER BUMPER PROTECTS WALLS, DOORWAYS, FURNITURE, ETC. 5" HARD RUBBER CASTERS, TWO SWIVEL AND TWO FIXED.

STOCK NO. JET140022

**STEEL UTILITY CARTS**



500LB. LOAD CAPACITY. 32" OVERALL HEIGHT. SOLID RUBBER 5" x 1-1/4" CASTERS. TRAY SIZE INDICATED BELOW WITH PART NUMBERS

STOCK NO. JET140023 (16"x30", 3" DEEP)  
STOCK NO. JET140024 (24"x36", 3" DEEP)

**STRUCTOLENE\* UTILITY CARTS**



HEAVY-DUTY SEAMLESS STRUCTURAL PLASTIC

STOCK NO.	DESCRIPTION	DIMENSIONS
CON5800	CART W/ 5" NON-MARKING CASTERS	32" x 16" x 30" 200 LBS./SHELF
CON5805	LARGE CART W/ 5" NON-MARKING CASTERS	32" x 24" x 36" 200 LBS./SHELF

**CASTERS**

**RIDGID CASTERS**



STOCK NO.	WHEEL SIZE	CASTER HEIGHT	WHEEL TYPE	CAP. LBS.
CAS12210441	2" x 7/8	2-3/4	A	90
CAS13008441	3" x 7/8	3-7/8	A	90
CAS3308909	3" x 1-1/2	4-3/8	A	290
CAS312395	3-1/2 x 1-1/4	4-5/8	A	225
CAS4312495	4" x 1-1/4	5"	A	275
3408909	4" x 1-1/4	5"	A	275
CAS4829397	4" x 2"	5-1/2	B	700
CAS5X112PR	5" x 1-1/2	6-3/8	A	400
CAS5829397	5" x 2"	6-1/2	B	1000
CAS6829397	6" x 2"	7-1/2	B	1200
CAS46108	6" x 2"	7-1/2	C	1200
CAS8829397	8" x 2"	9-1/2	B	1200

**ALL CASTERS ARE PLATE-MOUNTED**



**WHEEL TYPES**  
A) POLY ON STEEL      B) POLY ON POLY      C) ALL STEEL

**ADDITIONAL SIZES AND CASTERS AVAILABLE UPON REQUEST**

**SWIVEL CASTERS**



STOCK NO.	WHEEL SIZE	CASTER HEIGHT	WHEEL TYPE	CAP. LBS.
CAS12266441	2" x 7/8"	2-3/4	A	90
CAS13356441	3" x 7/8"	3-7/8	A	90
CAS3317909	3" x 1-1/2	4-3/8	A	290
CAS302395	3-1/2 x 1-1/4	4-5/8	A	225
CAS4302495	4" x 1-1/2	5"	A	275
CAS3417909	4" x 1-1/4	5"	A	275
CAS4819397	4" x 2"	5-1/2	B	700
CAS5X112PS	5" x 1-1/2	6-3/8	A	400
CAS5819397	5" x 2"	6-1/2	B	1000
CAS6819397	6" x 2"	7-1/2	B	1200
CAS46109	6" x 2"	7-1/2	C	1200
CAS8819397	8" x 2"	9-1/2	B	1200



### AIR CIRCULATORS



#### HEAVY-DUTY CIRCULATORS



30" BLADE SIZE. 2-SPEED, 1/2 HP MOTOR. 9850 CFM HIGH SPEED, 7500 CFM LOW SPEED. FACTORY-ASSEMBLED FAN HEAD. 12' LONG CORD, 3 CONDUCTOR, SJT TYPE. STEEL HUB AND SPIDER BLADE WITH ALUMINUM PADDLES. POWDER-COATED DOUBLE LOCKING STEEL WIRE GUARDS. COLUMN ADJUSTS FROM 4-1/2' TO 7'. 27" DIAMETER, HEAVY-DUTY STEEL BASE. SAFETY YELLOW. PULL CHAIN SWITCH. 5 YEAR LIMITED WARRANTY.

STOCK NO. TPIHD30P

OPTIONAL WHEEL KIT  
STOCK NO. HDWK

HEAVY-DUTY WALL MOUNT CIRCULATOR  
STOCK NO. TPIHD30W



#### HI-PERFORMANCE CIRCULATORS



30" BLADE SIZE. 2-SPEED, 1/3 HP MOTOR. 8200 CFM HIGH SPEED, 6200 CFM LOW SPEED. FACTORY-ASSEMBLED FAN HEAD. 12' LONG CORD, 3 CONDUCTOR, SJT TYPE. STEEL HUB AND SPIDER BLADE WITH ALUMINUM PADDLES. CHROME-PLATED DOUBLE LOCKING STEEL WIRE GUARDS. COLUMN ADJUSTS FROM 4-1/2' TO 7'. 27" DIAMETER, HEAVY-DUTY STEEL BASE. PULL CHAIN SWITCH. 3 YEAR LIMITED WARRANTY.

STOCK NO. TPIHP30P

HI-PERFORMANCE WALL MOUNT CIRCULATOR



STOCK NO. TPIHP30W

#### INDUSTRIAL CIRCULATORS



24" BLADE SIZE. 2-SPEED, 1/4 HP MOTOR. 6800CFM HIGH SPEED, 5000 CFM LOW SPEED. EASY TO ASSEMBLE. 12' LONG CORD, 3 CONDUCTOR, SJT TYPE. STEEL HUB AND SPIDER BLADE WITH ALUMINUM PADDLES. CHROME-PLATED DOUBLE LOCKING STEEL WIRE GUARDS. COLUMN ADJUSTS FROM 4-1/2' TO 7'. 27" DIAMETER, HEAVY-DUTY STEEL BASE. PULL CHAIN SWITCH. 1 YEAR LIMITED WARRANTY.

STOCK NO. TPIACU24P

INDUSTRIAL WALL MOUNT CIRCULATOR



STOCK NO. TPIACU24W

#### PREMIUM QUALITY HEAVY-DUTY OSCILLATING FAN HEADS



AVAILABLE IN 24" AND 30" PRE-ASSEMBLED HEADS (MOTOR, BLADE AND GUARD). 1/4 HP 3-SPEED MOTOR. DURABLE SAFETY CLUTCH-STYLE OSCILLATING MECHANISM. CAN BE SET TO OSCILLATE AT A 90° SWEEP, OR BE SECURED IN A FIXED POSITION. HEAD ASSEMBLY CAN BE TILTED 30° UP OR DOWN. AVAILABLE WITH WALL, FIXED OR ADJUSTABLE PEDESTAL MOUNTS.

SPECIFY WHEN ORDERING. 1 YEAR LIMITED WARRANTY.

STOCK NO. TPIACH24O (24" HEAD)  
STOCK NO. TPIACH30O (30" HEAD)

#### COMMERCIAL CIRCULATORS



COMMERCIAL PEDESTAL FAN. 30" SIZE. MOTOR IS 1/4 HP, 3-SPEED, 120V, 6000 CFM HIGH SPEED, 5500 CFM MEDIUM SPEED, AND 4800 CFM LOW SPEED. BALL BEARING, OPEN VENTILATED, PERMANENTLY LUBRICATED PERMANENT SPLIT CAPACITOR. THE SWITCH IS A PULL CHAIN. 9' LONG CORD, SJT TYPE. THE BLADES ARE ALUMINUM. THE POLE ADJUSTS CENTER OF THE FAN FROM 43" TO 60". MEETS OSHA STANDARDS. 1 YEAR LIMITED WARRANTY.

STOCK NO. TPICACU30P

#### INDUSTRIAL CEILING FANS



56 INCH, ALL METAL CONSTRUCTION. 21000 CFM'S. WHITE EPOXY FINISH. MOUNTS TO A 3/8" DIAMETER STEEL J-HOOK. ALUMINUM PADDLES. 24" DOWN ROD. FULLY ASSEMBLED EXCEPT BLADE BOLT DOWN. 3 CONDUCTOR CORD, 30" LONG WITH PLUG. SAFETY CABLE INCLUDED. DOWN DRAFT STYLE FOR SUMMER COOLING AND WINTER HEAT RECOVERY. 1 YEAR LIMITED WARRANTY.

STOCK NO. TPICHR56

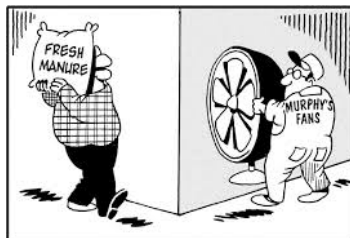





**MINI-BLOWER**



24" OR 30" BLADE SIZE AVAILABLE. 2-SPEED, 1/4 HP MOTOR. 6800 CFM HIGH SPEED, 5000 CFM LOW SPEED ON 24". 7800 CFM HIGH SPEED, 6000 CFM LOW SPEED ON 30". 10' LONG CORD, 3 CONDUCTOR, SJT

TYPE. STEEL HUB AND SPIDER BLADE WITH ALUMINUM PADDLES. SPIRAL WIRE FRONT AND REAR GUARD. POWDER-COATED 20 GAUGE STEEL DRUM. PULL CHAIN SWITCH. 1 YEAR LIMITED WARRANTY.

STOCK NO. **TPIMB24DF** 24"  
 STOCK NO. **TPIMB30DF** 30"

**DIRECT DRIVE PORTABLE BLOWER**



36" BLADE SIZE. 2-SPEED, 1/3 HP MOTOR. 12500 CFM HIGH SPEED, 9000 CFM LOW SPEED. ROCKER SWITCH. 12' LONG CORD, 3 CONDUCTOR, SJT TYPE. FRONT AND

REAR SPIRAL WIRE GUARDS. STEEL BLADE. POWDER COATED 20 GAUGE STEEL HOUSING HAS FRONT AND REAR ROLL EMBOSSEMENTS FOR ADDED STRENGTH AND RIGIDITY. 8" RUBBER WHEELS. 1 YEAR LIMITED WARRANTY.

STOCK NO. **TPIPB36D**

45" BLADE SIZE. 1 SPEED, 1/2 HP MOTOR. 15,600 CFM

STOCK NO. **TPIPB42D**

**BELT DRIVE PORTABLE BLOWERS**

36" AND 48" BLADE SIZE. 1-SPEED MOTOR. ROCKER SWITCH. POWDER-COATED 20 GAUGE STEEL HOUSING. ALUMINUM BLADES. FRONT AND REAR SPIRAL WIRE GUARDS. 12' LONG CORD, 3 CONDUCTOR, SJT TYPE. SWIVEL MODEL ROTATES 360° IN 12.5° INCREMENTS AND LOCKS IN PLACE. 10" HARD RUBBER WHEELS. 1 YEAR LIMITED WARRANTY.



**STANDARD MODEL**

STOCK NO. **TPIPB36B** (14500 CFM)  
**TPIPB48B** (22700 CFM)



**SWIVEL MODEL**

STOCK NO. **TPIPBS36B** (14500 CFM)  
**TPIPBS48B** (22700 CFM)

**AIR CIRCULATORS**



**OSCILLATING OFFICE FANS**



12" AND 16" FAN TO CHOOSE FROM. 3-SPEED OSCILLATING FANS WITH PUSH BUTTON CONTROLS. WIRE MESH GUARDS. STAND FAN EXTENDS TO 40" HEIGHT. 1 YEAR LIMITED WARRANTY



**DESK MODEL**  
 STOCK NO. **TPIODF12**  
 STOCK NO. **TPIODF16**

**FLOOR STAND MODEL**  
 STOCK NO. **TPIOSF16**

**WORK STATION FANS - 12 INCH**



1/12 HP, 3-SPEED, TOTALLY ENCLOSED MOTOR. 2750 CFM HIGH SPEED, 2200 CFM MEDIUM SPEED, 1600 LOW SPEED. MOUNTS WITH ONE BOLT OR LAG SCREW. FAN HEAD ROTATES 360° IN BOTH HORIZONTAL AND VERTICAL POSITION. 10' LONG CORD,

3 CONDUCTOR, SJT TYPE STEEL HUB AND SPIDER BLADE WITH ALUMINUM PADDLES. DOUBLE-LOCKING CHROME-PLATED STEEL WIRE GUARDS. PULL CHAIN SWITCH. 1 YEAR LIMITED WARRANTY.

STOCK NO. **TPIU12TE**

**WORK STATION FANS - 18 INCH**



1/8 HP, 3-SPEED, TOTALLY ENCLOSED MOTOR. 5750 CFM HIGH SPEED, 4700 CFM MEDIUM SPEED, 3200 LOW SPEED. MOUNTS WITH ONE BOLT OR LAG SCREW. FAN HEAD ROTATES 360° IN BOTH HORIZONTAL AND VERTICAL

POSITION. 10' LONG CORD, 3 CONDUCTOR, SJT TYPE STEEL HUB AND SPIDER BLADE WITH ALUMINUM PADDLES. DOUBLE-LOCKING CHROME-PLATED STEEL WIRE GUARDS. PULL CHAIN SWITCH. 1 YEAR LIMITED WARRANTY.

STOCK NO. **TPIU18TE**

**INDUSTRIAL FLOOR FAN**



ALL STEEL CONSTRUCTION. 24" BLADE SIZE, 3-SPEED, 1/8 HP, TOTAL ENCLOSED MOTOR. ROTARY SWITCH. 6350 CFM HIGH SPEED, 5200 CFM MEDIUM SPEED, 3600 CFM LOW SPEED. 10' LONG CORD, SJT TYPE. DOUBLE-LOCKING CHROME-PLATED GUARDS. STEEL HUB AND SPIDER BLADE WITH ALUMINUM PADDLES. 360° HEAD TILT. 1 YEAR LIMITED WARRANTY.

STOCK NO. **TPIF24TE**

**INDUSTRIAL FLOOR FANS**



ALL STEEL CONSTRUCTION. 18" BLADE SIZE. 3-SPEED, 1/8 HP, TOTALLY ENCLOSED MOTOR. ROTARY SWITCH.



5750 CFM HIGH SPEED, 4700 CFM MEDIUM SPEED, 3200 LOW SPEED. 10' LONG CORD, 3 CONDUCTOR, SJT TYPE. DOUBLE-LOCKING CHROME-PLATED GUARDS. STEEL HUB AND SPIDER BLADE WITH ALUMINUM PADDLES. 360° HEAD TILT. 53" HEIGHT ON PORTABLE MODEL. 1 YEAR LIMITED WARRANTY.

**STATIONARY**  
 STOCK NO. **TPIF18TE**

**PORTABLE**  
 STOCK NO. **TPIF18HTE**

**COMMERCIAL FLOOR FAN**



20" SIZE. 3-SPEED, 1/5 HP, OPEN VENTILATED, PERMANENTLY LUBRICATED, SLEEVE BEARING MOTOR. ROTARY SWITCH. 7' LONG CORD, SJT TYPE. ALUMINUM PADDLES. GUARDS ARE COATED STEEL WITH RETAINING CLIPS. MEETS OSHA STANDARDS. 1 YEAR LIMITED WARRANTY.

STOCK NO. **TPICF20**

BE CAREFUL OF YOUR THOUGHTS; THEY MAY BECOME WORDS AT ANY MOMENT.

--IARA GASSEN

OUR PRICES  
 WILL



BLOW YOU AWAY

**HEATERS**

**COMBINATION RADIANT AND FAN FORCED HEATER**



3-HEAT SETTINGS: 600 WATT RADIANT, 900 WATT FAN FORCED, AND 1500 WATT RADIANT AND FAN FORCED. TEMPERATURE CONTROL THERMOSTAT. DUAL SAFETY SYSTEM: TIP OVER SWITCH AND MANUAL RESET TYPE LIMIT CONTROL. 6' LONG CORD. 3 CONDUCTOR. 120V

**STOCK NO. TPI198TMC**

**MILK HOUSE HEATER**



FAN FORCED HEATER WITH 1500/1300 WATTS (FAN ONLY). 120V. 1 PH. 5120 BTUH. TEMPERATURE-CONTROL THERMOSTAT. TIP SWITCH AND OVERHEAT LIMIT.

**STOCK NO. TPI188TASA**

**FURNACE FILTERS**



STOCK NO.	DESCRIPTION
<b>FF1010</b>	10" x 10" x 1"
<b>FF1212</b>	12" x 12" x 1"
<b>FF1620</b>	16" x 20" x 1"
<b>FF1625</b>	16" x 25" x 1"
<b>FF2020</b>	20" x 20" x 1"
<b>FF20202</b>	20" x 20" x 2"
<b>FF2025</b>	20" x 25" x 1"

**SPECIAL-ORDER NON-STOCK ITEMS**

**CLEAR PVC STRIP DOORS**











A RELIABLE ENERGY SAVER CUSTOMIZED TO YOUR SPECIFICATIONS. SAVES ENERGY COSTS BY REDUCING AMOUNT OF HEATED OR COOLED AIR LOST THROUGH AN UNPROTECTED OPENING. PROVIDES DUST AND DIRT CONTROL, SIGNIFICANT NOISE REDUCTION, AND REQUIRES MINIMAL MAINTENANCE. SPECIAL ORANGE SAFETY STRIPS CLEARLY MARK LEFT AND RIGHT SIDES OF DOORS FOR IDENTIFICATION. AVAILABLE IN MANY TYPES (STANDARD CLEAR, LOW-TEMP, RIBBED, ETC.). MANY SIZES AND COLORS ALSO AVAILABLE. CALL US FOR MORE DETAILS.



**SHOVELS, SPADES & SCRAPERS**



<p align="center"><b>RAZOR-BACK</b> CONTRACTOR-DUTY OPEN-BACK SHOVELS</p>  <p>#2. SIZE 9-1/2 x 12" INDUSTRIAL-GAUGE BLADE ROLLED STEP. 2 RIVET, 11" TAB SOCKET. 48" LACQUERED PREMIUM ASH HANDLE.</p> <p>STOCK NO. UF45519 OR STOCK NO. SHV10* REPAIR HANDLE UF90580</p>	<p align="center"><b>UNION</b> STEEL COAL SHOVEL</p>  <p>#2 SIZE. 13-1/2 x 14-1/2 BLADE. 48" LACQUERED ASH HANDLE.</p> <p>STOCK NO. UF54246 OR STOCK NO. SHV42*</p>	<p align="center">CONTRACTOR-DUTY FIBERGLASS HANDLE</p>  <p>#2 SIZE 9-1/2 x 12" INDUSTRIAL-GAUGE OPEN-BACK BLADE. FORWARD-TURNED STEP. 48" SHAPED COMPOSITE FIBERGLASS HANDLE.</p> <p>STOCK NO. SHV14*</p>
<p align="center"><b>RAZOR-BACK</b> CONTRACTOR-DUTY REG. PURPOSE SHOVEL</p>  <p>#2 SIZE. 11-1/2 x 14-1/2 CARBON STEEL BLADE. 46" LACQUERED PREMIUM ASH HANDLE.</p> <p>STOCK NO. UF82102 OR STOCK NO. SHV45*</p>	<p align="center"><b>RAZOR-BACK</b> CONTRACTOR-DUTY TRENCHING SHOVEL</p>  <p>4" x 11-1/2 PARALLEL INDUSTRIAL-GAUGE BLADE. ROLLED STEP. 9" SOCKET. 48" LACQUERED PREMIUM ASH HANDLE.</p> <p>STOCK NO. UF47171 REPAIR HANDLE 90594</p>	<p align="center"><b>UNION</b> TOUGH-DUTY DURA-TORQUE SHOVEL</p>  <p>#2 SIZE. 9-1/4 x 11-1/2 OPEN-BACK BLADE. FORWARD-TURNED STEP. TORQUE BAND. 9" SOCKET 47" LACQUERED ASH HANDLE.</p> <p>STOCK NO. UF45106 REPAIR HANDLE 90377</p>
<p align="center"><b>RAZOR-BACK</b> CONTRACTOR -DUTY SOLID BACK SHOVEL</p>  <p>#2 SIZE. 9-3/4 x 11-1/4 INDUSTRIAL GAUGE BLADE. FORWARD-TURNED STEP. 10" SOCKET. 47" LACQUERED PREMIUM ASH HANDLE.</p> <p>STOCK NO. UF44010 REPAIR HANDLE UF90585</p>	<p align="center"><b>RAZOR-BACK</b> CONTRACTOR-DUTY SOLID-BACK DRAIN SPADE</p>  <p>4-3/4 x 16" INDUSTRIAL-GAUGE BLADE. FORWARD-TURNED STEP. 9" SOCKET. 27" LACQUERED PREMIUM ASH HANDLE W/ STEEL AND WOOD D-GRIP.</p> <p>STOCK NO. UF47110</p>	<p align="center"><b>RAZOR-BACK</b> CONTRACTOR-DUTY OPEN-BACK SHOVEL</p>  <p>#2 SIZE. 9-1/2 x 12" INDUSTRIAL-GAUGE BLADE ROLLED STEP. 2-RIVET, 11" TAB SOCKET. 48" LACQUERED PREMIUM ASH HANDLE.</p> <p>STOCK NO. UF44101 OR STOCK NO. SHV21* REPAIR HANDLE UF90580</p>

\* NOT UNION / RAZORBACK

**GET  
YOUR  
PROJECT  
STARTED  
TODAY**

<p align="center"><b>RAZOR-BACK</b> CONTRACTOR-DUTY CLOSED BACK SHOVEL</p>  <p>#2 SIZE. 9-1/2 x 12" INDUSTRIAL-GAUGE BLADE. FORWARD-TURNED STEP. 2-RIVET, 11" TAB SOCKET. 48" LACQUERED PREMIUM ASH HANDLE.</p> <p>STOCK NO. UF45657 OR STOCK NO. SHV11* REPAIR HANDLE UF90384</p>
---











\* NOT UNION / RAZORBACK

<p align="center"><b>UNION</b> TOUGH-DUTY DURA-TORQUE SHOVEL</p>  <p>#2 SIZE. 9-1/4 x 11-1/2 BLADE. ROLLED STEP. TORQUE BAND. 9" SOCKET. 48" LACQUERED PREMIUM ASH HANDLE.</p> <p>STOCK NO. UF44106 OR STOCK NO. SHV20*</p>
--

\* NOT UNION / RAZORBACK

FROM A PASSENGER SHIP ONE CAN SEE A BEARDED MAN ON A SMALL ISLAND WHO IS SHOUTING AND DESPERATELY WAVING HIS HANDS.  
"WHO IS IT?" A PASSENGER ASKS THE CAPTAIN.  
"I'VE NO IDEA. EVERY YEAR WHEN WE PASS, HE GOES MAD."











A GUY WALKED INTO THE TAX COLLECTOR'S OFFICE WITH A HUGE BANDAGE ON HIS NOSE. "HAD AN ACCIDENT?" ASKED THE TAX AGENT.  
"NO," ANSWERED THE MAN. "I'VE BEEN PAYING THROUGH IT FOR SO LONG, IT GAVE WAY UNDER THE STRAIN."

<p><b>RAZOR-BACK</b> CONTRACTOR-DUTY DITCHING SHOVEL</p>  <p>5" x 11-1/2" INDUSTRIAL-GAUGE BLADE. ROLLED STEP. 9" SOCKET. 48" LACQUERED PREMIUM ASH HANDLE.</p> <p>STOCK NO. UF47115 REPAIR HANDLE 90594</p>	<p><b>UNION</b> STEEL COAL SHOVEL</p>  <p>#4 SIZE. 14-1/2 x 15-1/2" BLADE. WIDE-FLARED DEEP DISH. 27" LACQUERED ASH HANDLE W/ STEEL AND WOOD D-GRIP.</p> <p>STOCK NO. UF54111 OR STOCK NO. SHV41*</p>	<p><b>UNION</b> STEEL COAL SHOVEL</p>  <p>#2 SIZE. 13-1/2 x 14-1/2" BLADE. 27" LACQUERED ASH HANDLE W/ STEEL AND WOOD D-GRIP.</p> <p>STOCK NO. UF54109 OR STOCK NO. SHV41*</p>
<p><b>RAZOR-BACK</b> CONTRACTOR-DUTY CLOSED-BACK DRAIN SPADE</p>  <p>4-3/4 x 16" INDUSTRIAL-GAUGE BLADE. FORWARD-TURNED STEP. 9" SOCKET. 29" LACQUERED PREMIUM ASH HANDLE W/ STEEL AND WOOD D-GRIP.</p> <p>STOCK NO. UF47103 OR STOCK NO. SHV55*</p>	<p><b>UNION</b> STEEL SCOOP</p>  <p>#2 SIZE. 11" x 15" EASTERN PATTERN BLADE. 27" LACQUERED ASH HANDLE W/ STEEL AND WOOD D-GRIP.</p> <p>STOCK NO. UF50139 OR STOCK NO. SHV44*</p>	<p><b>RAZOR-BACK</b> CONTRACTOR-DUTY ALUMINUM SCOOP</p>  <p>#14 SIZE. 15-1/4 x 19-3/4" WESTERN PATTERN BLADE. .101" THICK. ETCHED FINISH. 31" LACQUERED PREMIUM ASH HANDLE W/ STEEL AND WOOD D-GRIP.</p> <p>STOCK NO. UF53130 OR STOCK NO. SHV50*</p>
<p>* NOT UNION / RAZORBACK</p> <hr/> <p>ADDITIONAL ITEMS AVAILABLE CALL FOR DETAILS</p> <hr/> <p>AN ENGINEER, A MATHEMATICIAN, AND A PHYSICIST WERE STANDING AROUND THE UNIVERSITY FLAGPOLE WHEN AN ENGLISH PROFESSOR WANDERED BY. "WHAT ARE YOU DOING?" HE ASKED. "WE NEED TO KNOW THE HEIGHT OF THE FLAGPOLE," ANSWERED ONE, "AND WE'RE DISCUSSING THE FORMULAS WE MIGHT USE TO CALCULATE IT." "WATCH!" SAID THE ENGLISH PROFESSOR. HE PULLED THE POLE FROM ITS FITTING, LAID IT ON THE GRASS, BORROWED THE TAPE MEASURE AND SAID, "EXACTLY 24 FEET." THEN HE REPLACED THE POLE AND WALKED AWAY. "ENGLISH PROFESSOR!" SNEERED THE MATHEMATICIAN. "WE ASK HIM FOR THE HEIGHT, AND HE GIVES US THE LENGTH."</p>	<p><b>GARDEN SPADE</b></p>  <p>7-3/8 x 12" BLADE. TURNED STEP. 9" SOCKET. 28" LACQUERED ASH HANDLE WITH STEEL AND WOOD D-GRIP.</p> <p>STOCK NO. SHV24</p>	<p><b>RAZOR-BACK</b> CONTRACTOR-DUTY OPEN-BACK SHOVEL</p>  <p>#2 SIZE. 9-1/2 x 12" INDUSTRIAL-GAUGE BLADE. ROLLED STEP. 2 RIVET, 11" TAB SOCKET. 30" LACQUERED PREMIUM ASH HANDLE W/ STEEL AND WOOD D-GRIP.</p> <p>STOCK NO. UF42101</p>
<p><b>RAZOR-BACK</b> CONTRACTOR-DUTY SOLID BACK NURSERY SPADE</p>  <p>7-1/2 x 13" INDUSTRIAL-GAUGE BLADE. FORWARD TURNED STEP. 3 RIVET, 14" STEEL STRAP. 27" LACQUERED PREMIUM ASH HANDLE W/ STEEL AND WOOD D-GRIP.</p> <p>STOCK NO. UF46136</p>	<p><b>UNION</b> CONTRACTOR-DUTY OPEN-BACK SHOVEL</p>  <p>#2 SIZE. 9-1/4 x 11-1/2" BLADE. 9" SOCKET. 28" HANDLE WITH STEEL AND WOOD D-GRIP</p> <p>STOCK NO. UF42523 OR STOCK NO. SHV03*</p>	
<p>* NOT UNION / RAZORBACK</p>	<p>* NOT UNION / RAZORBACK</p>	

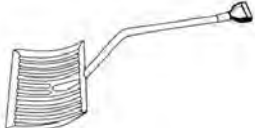

**SHOVELS, SPADES & SCRAPERS**

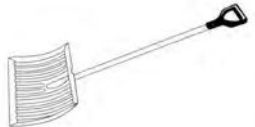

<p align="center"><b>RAZOR-BACK</b> CONTRACTOR-DUTY FORGED SCRAPER/CHOPPER</p>  <p>7" x 4" COLD FORGED BLADE WITH SHARPENED AND BEVELED EDGE. 54" HANDLE</p> <p>STOCK NO. UF81109 OR STOCK NO. SHV39*</p>	<p align="center"><b>UNION</b> TOUGH-DUTY FORGED SIDEWALK/ICE SCRAPER</p>  <p>SHANK PATTERN. 6" x 5" FORGED BLADE. STEEL FERULLE. 48" LACQUERED ASH HANDLE.</p> <p>STOCK NO. UF81102 OR STOCK NO. SHV38*</p>	<p align="center"><b>RAZOR-BACK</b> CONTRACTOR-DUTY FORGED SIDEWALK/ICE SCRAPER</p>  <p>SOCKET PATTERN. 7" x 6" INDUSTRIAL-GAUGE ONE-PIECE FORGED BLADE. 54" LACQUERED PREMIUM ASH HANDLE.</p> <p>STOCK NO. UF78202 OR STOCK NO. SHV36*</p>
<p align="center"><b>RAZOR-BACK</b> CONTRACTOR-DUTY OPEN-BACK SHOVEL</p>  <p>#2 SIZE. 9-1/2 x 12" INDUSTRIAL -GAUGE, OPEN BACK BLADE. 2 RIVET, 11" TAB SOCKET. 30" HANDLE W/ STEEL AND WOOD D-GRIP.</p> <p>STOCK NO. UF43201 OR STOCK NO. SHV22*</p>	<p align="center"><b>UNION</b> TOUGH-DUTY DURA-TORQUE SHOVEL</p>  <p>#2 SIZE. 9" x 11-1/2" BLADE. FORWARD-TURNED STEP. TORQUE BAND. 28" LACQUERED ASH HANDLE W/ STEEL AND WOOD D-GRIP.</p> <p>STOCK NO. UF43516 OR STOCK NO. SHV01*</p>	<p align="center"><b>UNION</b> ABS POLYMER GRAIN/SNOW SCOOP</p>  <p>EQUIVALENT TO #12 SIZE, BUT HOLDS 15% MORE. 14-3/4 x 18-3/4" BLADE. 29" LACQUERED ASH HANDLE W/ BIG GRIP POLY D-GRIP.</p> <p>STOCK NO. UF79770 OR STOCK NO. SHV48*</p>
<p align="center">* NOT UNION / RAZORBACK</p>	<p align="center">* NOT UNION / RAZORBACK</p>	<p align="center">* NOT UNION / RAZORBACK</p>
<p align="center"><b>AMES/TRUE TEMPER</b> HEAVY-DUTY SNOW HOG SNOW SHOVEL/PUSHER</p>  <p>20" x 13-3/4" POLYETHYLENE BLADE X-BRACE REINFORCED FOR ADDED STRENGTH. 38" CONTOURED METAL HANDLE W/ BIG GRIP POLY D-GRIP.</p> <p>STOCK NO. UF79741</p>	<p align="center"><b>AMES/TRUE TEMPER</b> HEAVY-DUTY STEEL SNOW PUSHER</p>  <p>24" x 11" SNO-SLIP COATED CARBON STEEL BLADE. 40" LACQUERED ASH HANDLE WITH D-GRIP HANDLE.</p> <p>STOCK NO. SHV98</p>	
<p align="center"><b>AMES/TRUE TEMPER</b> HEAVY-DUTY POLY SNOW SHOVEL/PUSHER</p>  <p>18" x 16-1/2" POLYETHYLENE BLADE X-BRACE REINFORCED FOR ADDED STRENGTH. 36" POLY HANDLE W/POLY SNOW D-GRIP.</p> <p>STOCK NO. UF79759</p>	<p align="center"><b>AMES/TRUE TEMPER</b> HEAVY-DUTY POLY SNOW PUSHER</p>  <p>24" x 13-1/2" POLYETHYLENE BLADE. X-BRACE REINFORCED FOR ADDED STRENGTH. 39" POLY ASH HANDLE WITH POLY SNOW D-GRIP.</p> <p>STOCK NO. UF79720</p>	
<p>DON'T WAIT AROUND FOR OTHER PEOPLE TO BE HAPPY FOR YOU. ANY HAPPINESS YOU GET YOU'VE GOT TO MAKE YOURSELF. --ALICE WALKER</p>	<p align="center"><b>HELPING MEET OUR CUSTOMERS NEEDS. IF THERE IS SOMETHING YOU DON'T SEE GIVE US A CALL.</b></p>	



**FORGED GARDEN HOE**



6" HEAD, 60" ASH HANDLE

**STOCK NO. UF66105 OR STOCK NO. SHV71\***

**CONTRACTOR-DUTY FORGED BOW RAKE**



15 TEETH. 16" x 3-1/4 ONE-PIECE FORGED HEAD, 1/4" THICK. TWISTED SHANK. EXTRA THICK END TEETH. 60" LACQUERED PREMIUM ASH HANDLE.

**STOCK NO. UF63141 OR STOCK NO. SHV75\***

**EZ-FLEX RAKE**



THE SOFT-TOUCH RAKE THAT SWEEPS DEBRIS FROM BOTH HARD AND SOFT SURFACES. STRAIGHT-EDGE GALVANIZED TINES AND DURABLE POLYPROPYLENE HEAD WON'T RUST. 18" WIDE (48" SCREW-IN VINYL COATED TUBULAR STEEL HANDLE).

**STOCK NO. UF64307**

**AMERICAN-PATTERN EYE-HOE**



7" ONE-PIECE FORGED BLADE WITH WOOD HANDLE.

**STOCK NO. SHV59\***

**UNION  
22" SPRING-BRACE LAWN RAKE**



SPRING STEEL HEAD W/ COIL-SPRING BRACE. 22 SPRING STEEL TINES. 48" LACQUERED HARDWOOD HANDLE.

**STOCK NO. UF64430 OR STOCK NO. SHV70\***

**RAZOR-BACK  
CONTRACTOR-DUTY FORGED  
POTATO/REFUSE HOOK**



4 HEAVY, BROAD, OVAL TINES, 7-1/2" LONG. DIAMOND POINT. 7" ONE-PIECE FORGED HEAD. 8" STEEL TUBE W/ CAP. 54" LACQUERED PREMIUM ASH HANDLE.

**STOCK NO. UF75138**

**CONTRACTOR-DUTY FORGED  
POTATO/REFUSE HOOK**



4- TINE ONE-PIECE FORGED HEAD. 60" LACQUERED PREMIUM ASH HANDLE.

**STOCK NO. UF75144 OR STOCK NO. SHV62\***

**RAZOR-BACK  
CONTRACTOR-DUTY ASPHALT/TAR RAKE**



15-1/2 x 4" FORGED HEAD, 11/32" THICK. 14 EXTRA-HEAVY STRAIGHT TEETH. 8" TUBE W/ CAP. 60" LACQUERED PREMIUM ASH HANDLE.

**STOCK NO. UF63125 OR STOCK NO. SHV76\***

**CONTRACTOR-DUTY ALUMINUM ASPHALT  
LUTE RAKES**



ALUMINUM HEAD. ONE EDGE OF BLADE SERRATED, ONE SMOOTH. 82" ALUMINUM HANDLE.

**STOCK NO. MILSA8430 (30")  
STOCK NO. MILSA8436 (36")  
STOCK NO. MILSA8442 (42")  
REPAIR HANDLE 99186**

**BOTH EDGES OF BLADE ARE SMOOTH.**

**STOCK NO. MILPA8430 (30")  
STOCK NO. MILPA8436 (36")  
STOCK NO. MILW05671 (30", WOOD HANDLE)**

**ALUMINUM LANDSCAPE RAKE**

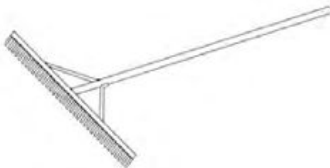

36" x 5" ALUMINUM HEAD W/ BOLTED BRACE. 37 HEAVY-DUTY TEETH. 66" ALUMINUM HANDLE.  
**STOCK NO. MILLA6636\***

36" x 5" HEAD WITH 84" HANDLE  
**STOCK NO. MILLA8436\***

**RAZOR-BACK  
CONTRACTOR-DUTY FORGED MORTAR MIXER**



10" x 6" ONE-PIECE FORGED BLADE, PERFORATED FOR MIXING. 8" TUBE W/ CAP. 5/8" GOOSENECK SHANK. 66" LACQUERED PREMIUM ASH HANDLE.

**STOCK NO. UF66158 OR STOCK NO. SHV60\***

**RAZOR-BACK  
CONTRACTOR-DUTY CONCRETE RAKE W/ HOOK**



20" x 4" BLADE. STEEL SOCKET NAILED TO HANDLE. HOOK FOR POSITIONING REINFORCEMENT WIRE. 60" LACQUERED PREMIUM ASH HANDLE.

**STOCK NO. UF83154 OR STOCK NO. SHV61\***

\* NOT UNION / RAZORBACK

\* NOT UNION / RAZORBACK

\* NOT UNION / RAZORBACK



**CUTTING TOOLS, FORKS AND DIGGERS**



**UNION  
GRASS TRIMMER**



8-1/2 x 2-1/4 SERRATED, BEVELED AND SHARPENED BLADE. 30" LACQUERED ASH HANDLE.

STOCK NO. UF62101 OR STOCK NO. SHV68\*

**UNION  
TOUGH-DUTY WEED CUTTER**



14" x 2-1/2 SERRATED, BEVELED BLADE. 30" LACQUERED ASH HANDLE. 40" OVERALL LENGTH.

STOCK NO. UF62105 OR STOCK NO. SHV67\*  
REPLACEMENT BLADE UF99034

**TAMPERS**



ALL STEEL TAMPER. 10" x 10" HEAD, 43" LENGTH.  
STOCK NO. UF30005



ALL STEEL TAMPER. 8" x 8" HEAD, 43" LENGTH.  
STOCK NO. MILHTS8X8\*



HEAVY DUTY CAST IRON 8" x 8" HEAD, 12 LB. WOOD HANDLE. 48" LENGTH.  
STOCK NO. SHV84\*



HEAVY DUTY CAST IRON 10" x 10" HEAD, 17 LB. WOOD HANDLE. 48" LENGTH.  
STOCK NO. SHV85\*

\* NOT UNION / RAZORBACK

**CONTRACTOR-DUTY HERCULES  
POSTHOLE DIGGER**



6-1/4 x 9" HIGH-CARBON STEEL BLADES. 6" BETWEEN TIPS. 48" SQUARE-TO-ROUND CUT FIBERGLASS HANDLES. FOR HARD SOIL.

STOCK NO. UF78172 OR STOCK NO. SHV57\*

**CONTRACTOR-DUTY POSTHOLE DIGGER**



6-1/4 x 9" HIGH-CARBON STEEL BLADES. 6" BETWEEN TIPS. 72" FIBERGLASS HANDLES. FOR HARD SOIL.

STOCK NO. UF78174

**24" BOW SAW**

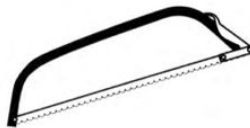

HEAT TREATED CUTTING EDGES. BLADE SHIELD. TUBULAR STEEL HANDLE WITH CUSHION GRIP.

STOCK NO. OLY66846\*

\* NOT UNION / RAZORBACK

**CAN'T FIND IT?**



**RAZOR-BACK  
CONTRACTOR-DUTY FORGED GARDEN  
SPADING FORK**



MEDIUM PATTERN. 4 ANGULAR-BACK TINES, 11" LONG. ONE-PIECE FORGED HEAD. 10" FERRULE W/ CAP. 30" LACQUERED PREMIUM ASH HANDLE W/ STEEL AND WOOD D-GRIP.

STOCK NO. UF72103 OR STOCK NO. SHV64\*

**RAZOR-BACK  
CONTRACTOR-DUTY FORGED  
MANURE FORK**



4 TINES, ONE-PIECE FORGED HEAD. 8" FERRULE W/ CAP. 48" LACQUERED PREMIUM ASH HANDLE.

STOCK NO. UF74102 OR STOCK NO. SHV66\*

**RAZOR-BACK  
CONTRACTOR-DUTY FORGED  
MANURE FORK**



5 TINES, ONE-PIECE FORGED HEAD. 8" FERRULE W/ CAP. 48" LACQUERED PREMIUM ASH HANDLE.

STOCK NO. UF74113 OR STOCK NO. SHV65\*

**HEDGE SHEARS**

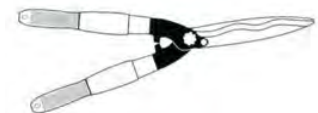

10" WAVY BLADE. COMPOUND ACTION HEAD. ADJUSTABLE TENSION KNOB. HARDWOOD HANDLES. NO-SLIP TEXTURED VINYL CUSHION GRIP.

STOCK NO. UF62427\*

\* NOT UNION / RAZORBACK

**CUTTING TOOLS, DIGGERS & MISC.**

**LOPPING SHEARS**



FORGED BY-PASS LOPPER, 21" HEAVY DUTY HARDWOOD HANDLES, LARGE CAPACITY HEAD.

STOCK NO. SHV69

**LIL' HOG SHOVEL (MINI)**



A HEAVY-DUTY COMPACT SHOVEL IDEAL FOR TOUGH JOBS. USE IN TIGHT SPACES, IN TRACK CLEANING, AND FOR CONCRETE FORM WORK. LIGHTWEIGHT. 6" x 8-1/2 x 27-1/2.

STOCK NO. UF45107 OR STOCK NO. SHV15

**PERFECT CUT**

**11' TELESCOPING TREE PRUNER**

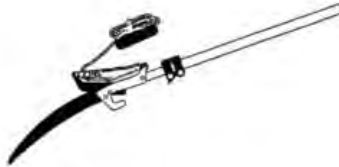

TEFLON COATED PRUNING BLADE. TWIN PULLEYS. FIBERGLASS HANDLE.

STOCK NO. UF62932

**LIL' HOG MORTAR HOE (MINI)**



A HEAVY-DUTY COMPACT MORTAR HOE IDEAL FOR TOUGH JOBS. USE IN TIGHT SPACES. LIGHTWEIGHT. 6" x 5" x 22".

STOCK NO. UF66168

**STEEL HAND ROLLER**



14" x 15". IDEAL TOOL FOR ASPHALT WORK.

STOCK NO. MILHR180A

**SPREADERS**

IDEAL FOR APPLYING PLANT FOODS AND FERTILIZERS, GRANULAR BAITS, INSECTICIDES, AND HERBICIDES TO LARGE AREAS. APPLY GRANULAR ICE MELTING PRODUCTS SUCH AS ROCK SALT, CALCIUM CHLORIDE OR SIMILAR PRODUCTS



STOCK NO. MD49408

**HAND HELD SPREADER**



STOCK NO. MD49407



THEN THERE WAS THE FELLOW WHO ALWAYS HAD BAD LUCK. ONCE HE FOUND A MAGIC LAMP, RUBBED IT, AND A GENIE APPEARED AND GAVE HIM THE MIDAS TOUCH. FOR THE REST OF HIS LIFE, EVERYTHING HE TOUCHED TURNED INTO A MUFFLER.

TOOLS  
FOR  
EVERY  
JOB



**HEAVY-DUTY CONTRACTOR WHEELBARROWS & ACCESSORIES**

**STEEL WHEELBARROWS**

6-1/4" CUBIC FT. STORAGE CAPACITY. 10 GA. SUPPORT PLATE. DOUBLE-LAPPED 16 GA. WELDED TRAY. CONTINUOUS 5/16" ROD UNDER RIM. 14 GA. V-SHAPED TRAY BRACES. 1/4" WHEEL GUARD. ONE-PIECE U-CANNEL ASSEMBLY. 80% LOAD ON TIRES, 20% LOAD ON HANDLES.

**SELECT HARDWOOD FRAME AND HANDLES**



STOCK NO. SHE01 (PNEUMATIC TIRE)  
 STOCK NO. SHE04 (SOLID RUBBER TIRE)

**HEAVY-DUTY STEEL FRAME AND HANDLES**



STOCK NO. SHE02 (PNEUMATIC TIRE)  
 STOCK NO. SHE05 (SOLID RUBBER TIRE)

**2-WHEEL WHEELBARROW - PNEUMATIC TIRES-  
 6-1/4 CUBIC FT.**



**SELECT HARDWOOD FRAME AND HANDLES**

STOCK NO. SHE03

**ALL WHEELBARROWS  
 COME ASSEMBLED!**

*ADDITIONAL WHEELBARROWS AVAILABLE  
 UPON REQUEST*

**ACCESSORIES AND REPLACEMENT  
 PARTS  
 FOR STEEL WHEELBARROWS**

**16 GA. DOUBLE-LAPPED WHEELBARROW TRAY**  
 6-1/4 CUBIC FT. STORAGE CAPACITY.



STOCK NO. SHE30

**SEMI-PNEUMATIC TIRE AND WHEEL ASSEMBLY**



FOR SINGLE-WHEEL WHEELBARROW ONLY.  
 STOCK NO. SHE19

**PNEUMATIC TIRE AND WHEEL ASSEMBLY**



FOR SINGLE-WHEEL WHEELBARROW ONLY.  
 STOCK NO. SHE21

FOR DUAL WHEEL WHEELBARROW.  
 STOCK NO. SHE22

POLYURETHANE TIRE AND WHEEL ASSEMBLY.  
 SOLID FOAM FILLED WITH 500 LB. CAPACITY.  
 RED IN COLOR  
 STOCK NO. SHE18

**WOOD WHEELBARROW HANDLE**



STOCK NO. SHE35

MANNERS ARE LIKE THE ZERO IN ARITHMETIC;  
 THEY MAY NOT BE MUCH IN THEMSELVES, BUT  
 THEY ARE CAPABLE OF ADDING A GREAT DEAL  
 TO THE VALUE OF EVERYTHING ELSE.

--FREYA STARK

**POLYETHYLENE WHEELBARROWS**



10 CUBIC FT. STORAGE CAPACITY. HEAVY-DUTY WOOD FRAME. 2-WHEEL CHASSIS.

STOCK NO. WHB05

*ADDITIONAL POLYETHYLENE WHEELBARROWS  
 AVAILABLE UPON REQUEST*

**HEAVY-DUTY STEEL TUB AND WOOD HANDLES**



STOCK NO. WHB02

**16" WHEEL ASSEMBLY**

STOCK NO. UF99366

**ALL WHEELBARROWS  
 COME ASSEMBLED!**

This is a comprehensive catalog of our major lines and services.

BUT

It does not show ALL available product lines. If there is something you need that is not shown, we either carry it ... or can get it. Please call and we will do everything possible to help you.



### GASOLINE CANS & OILERS

#### METAL SAFETY CANS



**TYPE I SAFETY**

- ♦ IDEAL FOR TRANSPORTATION AND STORAGE OF FLAMMABLE LIQUIDS.
- ♦ SPRAY DEFLECTOR AVAILABLE.
- ♦ HEAVY GAGE GALVANIZED STEEL.
- ♦ SINGLE SPRING-CLOSING FILL AND POUR SPOUT.
- ♦ FLASH ARRESTOR.
- ♦ OSHA, UL, FM APPROVED.



**TYPE II SAFETY**

- ♦ IDEAL FOR STORAGE AND DISPENSING OF FLAMMABLE LIQUIDS.
- ♦ HEAVY GAGE GALVANIZED STEEL.
- ♦ FILL SPOUT AND SEPARATE POUR VALVE W/ FLEXIBLE NOZZLE.
- ♦ ONE HAND POUR CONTROL.
- ♦ FLAME ARRESTOR.
- ♦ OSHA, UL, FM APPROVED.



**OILY WASTE CAN**

- ♦ IDEAL FOR DISPOSAL OF SOLVENT & OILY WASTE, RAGS, SWABS AND OTHER MATERIALS SUBJECT TO SPONTANEOUS COMBUSTION.
- ♦ COMES WITH FOOT LEVERS AND MEETS OSHA REQUIREMENTS.



**TYPE I SAFETY**

- ♦ METAL POUR FUNNEL
- ♦ 3/4" x 10" FLEXIBLE METAL HOSE



**TYPE I SAFETY**

- ♦ POINT-N-POUR POLYETHYLENE FUNNEL.
- ♦ 8-1/4" LONG.

**STOCK NO.**

**DESCRIPTION**

- SWM100**
- SWM102**
- SWM102Y**
- SWM1025**
- SWM105**
- SWM105Y**
- SWM200**
- SWM202**
- SWM2025**
- SWM205**
- SWMSFC15**
- SWMF347**
- SWMPFF8**
- SWMR3409**

- 1 GALLON TYPE I SAFETY GAS CAN
- 2 GALLON TYPE I SAFETY GAS CAN
- 2 GALLON TYPE I SAFETY DIESEL FUEL CAN
- 2-1/2 GALLON TYPE I SAFETY GAS CAN
- 5 GALLON TYPE I SAFETY GAS CAN
- 5 GALLON TYPE I SAFETY DIESEL FUEL CAN
- 1 GALLON TYPE II SAFETY GAS CAN
- 2 GALLON TYPE II SAFETY GAS CAN
- 2-1/2 GALLON TYPE I SAFETY GAS CAN
- 5 GALLON TYPE II SAFETY GAS CAN
- 15 GALLON OILY WASTE CAN
- METAL POUR FUNNEL
- POLYETHYLENE POUR FUNNEL
- 3/4" x 9" METAL TYPE II SAFETY REPLACEMENT SPOUT

#### BLITZ CAN AND SPOUT



RED BLITZ CAN MADE OF 20 GAUGE STEEL TO US ARMY SPECIFICATIONS (MIL-C-1283). CARRIES APPROVAL (ICC) FOR TRANSPORTING COMBUSTIBLE FUELS. EXTRA CAPACITY FOR ADDITION OF OIL. SCREW-ON SPOUT HAS PLATED FINISH WITH SCREEN AND DUST CAP.

**STOCK NO.**

**DESCRIPTION**

- BR690** 5 GALLON CAN W/CAP
- BR690A** 1-1/4" DIA. SCREW-ON SPOUT

#### HEAVY DUTY PLASTIC FUEL CONTAINERS



**STOCK NO.**

**DESCRIPTION**

- IG1406** 2-1/2 GALLON - RED - GASOLINE
- IG1408** 5 GALLON - RED - GASOLINE
- IG1419** 5 GALLON - BLUE - KEROSENE
- IG1420** 5 GALLON - YELLOW - DIESEL

#### FLEXIBLE POUR SPOUT

MULTI-PURPOSE POUR SPOUT FOR AUTO, HOME AND OTHER USES. TWO THREAD SIZES TO FIT MOST CONTAINERS. SCREWS DIRECTLY TO MOTOR OIL, ANTI-FREEZE, AND OTHER FLUID CONTAINERS. COMPLETE WITH STOPPER CAP AND HANG TAB.

**STOCK NO. LUMLX1610**



#### OILERS PISTOL TYPE OILERS



DELIVERS POSITIVE STREAM. TRIGGER ACTION PLUNGER PUMPS FLUID AT HIGH PRESSURE. COMFORTABLE HAND FIT. ALL METAL PUMP MECHANISM AND SPOUTS.

**STOCK NO.**

**DESCRIPTION**

- BR314** 6 OZ. - 6" RIGID SPOUT - BLUE POLYETHYLENE BODY
- BR314F** 6 OZ. - 6" FLEX SPOUT - BLUE POLYETHYLENE BODY
- BR314FB** 6" REPLACEMENT FLEX SPOUT (NOT SHOWN)

#### PUMP OIL TYPE



POSITIVE TRIGGER PUMPING UNIT - TRIGGER CONTROL. ALL METAL SPOUTS AND PUMP MECHANISM. BLUE ENAMEL FINISH.

**STOCK NO.**

**DESCRIPTION**

- BR324** 3/4 PINT - 6" RIGID SPOUT
- BR324B** 6" REPLACEMENT RIGID SPOUT FOR 324
- BR353B** 1/3 PINT OILER - METAL BODY
- BR355** 3/4 PINT - 8" FLEX SPOUT
- BR355B** 8" REPLACEMENT FLEX SPOUT FOR 355
- BR356** 1 PINT - 13" FLEX SPOUT
- BR357** 1 QUART - 13" FLEX SPOUT
- BR356B** 13" REPLACEMENT FLEX SPOUT FOR 356 & 357

#### HANDI-GRIP OILERS



LEAKPROOF BODIES-POWERFUL PUMP MECHANISM. DELIVERS OIL IN FULL STREAM OR ONE DROP ONLY DEPENDING ON PRESSURE APPLIED. BLUE ENAMEL FINISH.

**STOCK NO.**

**DESCRIPTION**

- BR361** 1 PINT - 6" ANGLE RIGID SPOUT
- BR361F** 1 PINT - 7 5/8" FLEX SPOUT
- BR363** 1 QUART - 6" ANGLE RIGID SPOUT-METAL BODY

**MEASURES, DRAIN PANS, FUNNELS & BUCKETS**

**FLOW CONTROL**



THUMB OPERATED FLOW CONTROL VALVE THAT LOCKS OPEN. ONE HAND OPERATION. TAPERED TO PREVENT SPILLS. CLEAR DRAIN RECESSED BOTTOM. FLEXIBLE AND RIGID SPOUT TYPES. ALUMINUM LIFETIME LUSTER FINISH. RIGID SPOUT MODELS HAVE SELF-ADJUSTING, LEAK-PROOF SWIVELS.

STOCK NO.	CAPACITY/DESCRIPTION
BR101	1 QT. 13-1/2" FLEX SPOUT
BR102	2 QT. 17" FLEX SPOUT
BR804	4 QT. 18" FLEX SPOUT

**GALVANIZED COMBINATION MEASURES**



EXTRA STRONG, HEAVY GAUGE BLACK STEEL. DOUBLE SEEMED AND HOT DIP GALVANIZED. STURDY HANDLE FOR EASY POURING.

STOCK NO.	CAPACITY/DESCRIPTION
BR512	2 QT. WITH RIDGID SPOUT
BR672	2 QT. WITH FLEX SPOUT
BR674	4 QT. WITH FLEX SPOUT

**OVAL RADIATOR FILLER HOT DIPPED GALVANIZED**



CURVED SPOUT TO REACH RADIATOR INTAKE. REST LUG, PISTOL GRIP, SWINGING BAIL HANDLE WITH GRIP.

STOCK NO.	CAPACITY
BR501	12 QT.

**SERVICE  
YOU CAN  
DEPEND ON**

**GALVANIZED DRAIN PANS**



MODEL 673: ONE PIECE DRAWN 26 GAUGE GALVANIZED UTILITY PAN. FOR WASHING PARTS AND DRAINING SMALL RADIATORS AND CRANKCASES. FLANGED LIP FOR CARRYING.

MODEL 677: ONE PIECE SEAMLESS GALVANIZED STEEL BODY. RIBBED FOR EXTRA STRENGTH. NEW 3 POINT SUSPENSION HANDLES. WILL NOT LEAK, SLIP OR TILT.

STOCK NO.	CAPACITY
BR677	6 GAL.
BR673	3-1/4 GAL.

**FUNNELS**

**GALVANIZED METAL FUNNELS**



LOCK SEAMS, RESISTS RUST AND CORROSION. GROOVED FUNNEL SPOUTS FOR AIR VENTING.

STOCK NO.	CAPACITY/DESCRIPTION
BR1148	1 QT. - 6" DIA. FLEX SPOUT & SCREEN
BR545	1 QT. - 6-1/4" DIA. NO SCREEN
BR546*	2 QT. - 8" DIA. WITH SCREEN
BR551*	8 QT. - 11-7/8" DIA. CENTER

\*GALVANIZED

**FUNNELS**



LOW COST FOR POWER MOWERS, OUTBOARDS, GARAGE, GASOLINE, HOME AND SHOP USE.

STOCK NO.	CAPACITY/DESCRIPTION
BR561	1/2 PINT - NO SCREEN (PLASTIC)
BR562	1 PINT - NO SCREEN (METAL)
BR582	1 PINT - NO SCREEN (PLASTIC)
DOVF25	1-1/2 PINT - NO SCREEN (METAL)

**FUNNELS (CONT.)**

**FILL-FAST PLASTIC FUNNELS**



HEAVY DUTY RED POLYETHYLENE. RUST AND CORROSION PROOF. HANDLES ALL LIQUIDS. BUILT-IN FINE MESH BRASS FILTERING SCREEN. HANGING TABS. THEY FLOAT-IDEAL FOR MARINE USE.

STOCK NO.	CAPACITY/DESCRIPTION
BR572	2 QT. - 7" DIA. WITH SCREEN
BR573	6 QT. - 9" DIA. WITH SCREEN

**LONG NECK FUNNEL**



STOCK NO.	CAPACITY/DESCRIPTION
AP18F	1-1/2 TO 2 QT. NO SCREEN (PLASTIC)

**5 GALLON PLASTIC BUCKET & LID**



STOCK NO.	DESCRIPTION
BUCK11	LID
BUCK5	BUCKET

**5 GALLON METAL BUCKET & LID**



STOCK NO.	DESCRIPTION
BUCK21	LID
BUCK2	BUCKET

**TIN CANS WITH LIDS**



STOCK NO.	SIZE
TC01	1 PINT
TC02	1 QUART
TC03	1 GALLON



**IGLOO INDUSTRIAL CONTAINERS**



**STURDY JUG CONTAINERS**



HANDY UTILITY CONTAINER TO KEEP WATER EASILY AVAILABLE. HEAVY DUTY POLYETHYLENE CONSTRUCTION. 6 INCH ANGLED DETACHABLE POUR SPOUT WITH CAP. AIR VENT FOR SMOOTH POURING. CONTOURED TOP HANDLE FOR EASY CARRYING. LOWER SIDE HANDLE MAKES POURING EASY.

STOCK NO.	COLOR BODY	CAPACITY	DESCRIPTION
IG1402	BLUE	6 GAL.	STURDY JUG

**THIS VALUABLE CATALOG IS YOUR GUIDE TO EFFICIENT BUYING**



**ALL-PLASTIC INDUSTRIAL COOLERS**  
*400 SERIES PLASTIC WATER COOLERS*

- BRIGHT SAFETY YELLOW AND RED COLOR FOR EASY IDENTIFICATION WILL NOT FADE IN DIRECT SUNLIGHT.
- HEAVY DUTY "ULTRATHERM" POLYURETHANE FOAM INSULATION.
- ALL PLASTIC RUST PROOF CONSTRUCTION AND EASY TO CLEAN WHITE LINER RESISTS STAINS AND ODORS.
- WIDE MOUTH OPENING FOR EASY FILLING, ESPECIALLY BLOCK ICE.
- TIGHT SEALING, PRESSURE FIT LID WITH TOP HANDLE FOR EASY OPENING.
- PLASTIC, RECESSED, DRIP PROOF, PUSH BUTTON SPIGOT.

**MODEL 421 - 2 GALLON CAPACITY**



REINFORCED BALL HANDLE, LOCKS LID FOR CARRYING. DIMENSIONS: 14-3/4 x 11-3/4.  
**STOCK NO. IG421**

**MODEL 431 - 3 GALLON CAPACITY**



REINFORCED BALL HANDLE. BRACKET FOR OPTIONAL CUP DISPENSER. DIMENSIONS: 14-3/4 x 13".  
**STOCK NO. IG431**

**MODEL 451 - 5 GALLON CAPACITY**



HEAVY DUTY, REINFORCED SIDE HANDLES. CUP DISPENSER BRACKET. DIMENSIONS: 21-1/4 x 13".  
**STOCK NO. IG451**

**MODEL 4101 - 10 GALLON CAPACITY**



HEAVY DUTY, REINFORCED SIDE HANDLES. CUP DISPENSER BRACKET. DIMENSIONS: 23-1/2 x 16".  
**STOCK NO. IG4101**

**PAPER CUPS**



4 OZ./200 PACK  
**STOCK NO. IG4**

**PAPER CUP DISPENSERS**



FITS ALL PLASTIC INDUSTRIAL COOLERS EXCEPT 2 GAL.  
**STOCK NO. IG8242**

**TRUCK RACKS**



FITS MODELS 431 AND 451. CAN BE ATTACHED ANYWHERE. STURDY METAL RACK HOLDS COOLER SECURELY.  
**STOCK NO. IG9551**

WE STOCK OVER 30,000 ITEMS

IF YOU DON'T SEE THE ITEM YOU NEED, PLEASE GIVE US A CALL

**TOOL BOXES, SPECIAL PURPOSE BOXES INDUSTRIAL CONTAINERS**

**BRUSHED STEEL TOOL BOXES**



15 INCH, HEAVY GAUGE STEEL NON-CORROSIVE BASE. REMOVABLE INNER TRAY. HEAVY DUTY STEEL LATCHES.

**NO. PTB22016**



20 INCH. HEAVY GAUGE STEEL NON-CORROSIVE BASE. REMOVABLE INNER TRAY. HEAVY DUTY STEEL LATCHES.

**STOCK NO. PTB22020**



23 INCH. HEAVY GAUGE STEEL NON-CORROSIVE BASE. REMOVABLE INNER TRAY. HEAVY DUTY STEEL LATCHES. DEEP UTILITY DESIGN. CUTTING BRACE DECK LID.

**STOCK NO. PTB22023**



26 INCH. HEAVY GAUGE STEEL NON-CORROSIVE BASE. REMOVABLE INNER TRAY. HEAVY DUTY STEEL LATCHES. CUTTING BRACE DECK LID.

**STOCK NO. PTB22026**

**PLASTIC SHELF BINS**

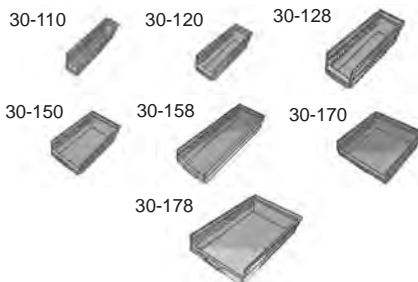

ECONOMY BINS FOR 12" AND 18" DEEP SHELVING OR AUTOMATED STORAGE AND RETRIEVAL UNITS. MOLDED OF DURABLE POLYPROPYLENE. SPECIAL BUILT-IN HANGLOCK ALLOWS EASY ACCESS TO THE ENTIRE BIN. MOLDED-IN WIDE LABEL HOLDER. STOCKED IN RED. ADDITIONAL COLORS AVAILABLE UPON REQUEST.

STOCK NO.	SIZE	COLOR
AK30110	2-3/4 x 12"	RED
AK30120	4-1/8 x 12"	RED
AK30128	4-1/8 x 18"	RED
AK30130	6-5/8 x 12"	RED
AK30138	6-5/8 x 18"	RED
AK30150	8-3/8 x 12"	RED
AK30158	8-3/8 x 18"	RED
AK30170	11-1/8 x 12"	RED
AK30178	11-1/8 x 18"	RED

**PLASTIC BIN DIVIDERS**



STOCK NO.	SIZE
AK40120	4-1/8
AK40130	6-5/8
AK40150	8-3/8
AK40170	11-1/8

**AKRO-BINS**

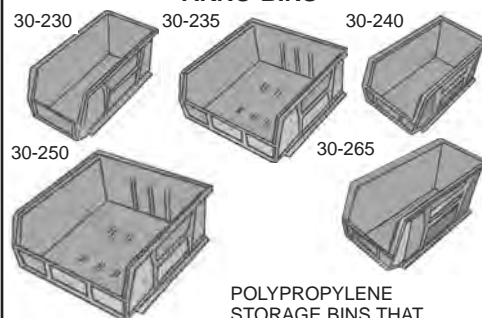

POLYPROPYLENE STORAGE BINS THAT HANG OR STACK (30265 DOES NOT HANG). ANTI-SLIDE STOP PREVENTS LOADED BINS FROM SHIFTING. LARGE LABEL SLOT FOR IDENTIFICATION. EASY HANDLING FINGER GRIPS. STOCKED IN RED.

STOCK NO.	SIZE	COLOR
AK30230	5-1/2 x 10-7/8"	RED
AK30235	11" x 10-7/8"	RED
AK30240	8-1/4 x 14-3/4"	RED
AK30250	16-1/2 x 14-3/4"	RED
AK30265	8-1/4 x 18"	RED

**AKRO-BIN DIVIDERS**



STOCK NO.	BIN NO.
AK40230	30-230, 30-235
AK40245	30-240, 30-250
AK40265	30-265

**STAK-N-STORE BIN**



MEDIUM SIZED ALL-PURPOSE CONTAINER THAT STACKS FOR COMPACT STORAGE OF PARTS AND TOOLS. POLYETHYLENE DESIGN FOR STRENGTH AND CHEMICAL RESISTANCE. SPILL CHANNEL IN BOTTOM TO CATCH EXCESS LIQUID. AVAILABLE IN GRAY. 19-7/8" W x 15-1/4" L x 12-7/16" H.

**STOCK NO. AK13017**

**CARDBOARD BIN BOXES**

**SELF-LOCKING**

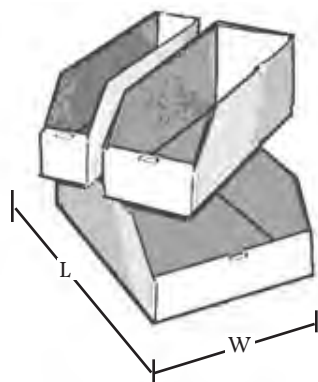

STOCK NO.	SIZE	
	W	L
MCBB1	2"	12"
MCBB2	4"	12"
MCBB3	6"	12"
MCBB4	8"	12"
MCBB5	2"	18"
MCBB6	4"	18"
MCBB186	6"	18"
MCBB188	8"	18"

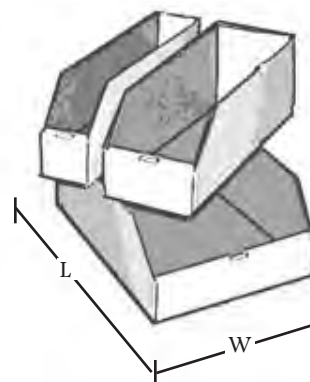

**ADDITIONAL SIZES AVAILABLE UPON REQUEST**

**METAL STORAGE BINS**

**PARTS TRAYS**

**L-SERIES  
LARGE DRAWER BOXES**

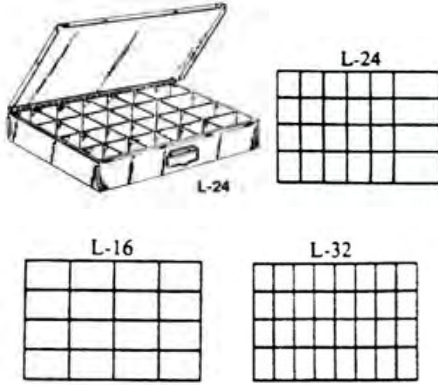

3" H x 18" W x 12" D.

16 COMPARTMENT TRAY  
STOCK NO. MFL16

24 COMPARTMENT TRAY  
STOCK NO. MFL24

32 COMPARTMENT TRAY  
STOCK NO. MFL32

**"EXPANDO" LARGE PARTS TRAY**



EXCELLENT FOR STORAGE OF SMALL PARTS, BUT ALLOWS MORE VERSATILITY DUE TO ADJUSTABLE DIVIDERS FOR LARGER PARTS. INCLUDES 12 DIVIDERS. 3" H x 18" W x 12" D.

STOCK NO. MFL4X

ADDITIONAL ITEMS AVAILABLE UPON REQUEST

**SLIDE RACKS**

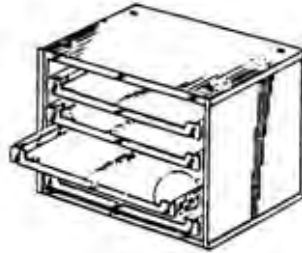

**4 DRAWER LARGE SLIDE RACK**

FOUR SLIDE-OUT TRAYS TO USE WITH L-SERIES DRAWERS. HELPS MAXIMIZE STORAGE SPACE. 14-3/4" H x 20-1/4" W x 12-3/4" D.

STOCK NO. MFL24R

**PARTS CABINETS**

19-228



19-320



19-416



19-909



PERFECT FOR SMALL PARTS STORAGE. HEAVY-DUTY MODULAR CABINETS FEATURE STEEL FRAMES AND DRAWER SUPPORTS. CHARCOAL GRAY BAKED ENAMEL FINISH. DRAWERS MOLDED OF GRAY STYRENE WITH TRANSPARENT WINDOWS AND A RETAINING TAB. DRAWER DIVIDERS INCLUDED. EASY MOUNTING AND FEET FOR SAFE STACKING.

STOCK NO.	DESCRIPTION
AK19228	28 DRAWER
AK19320	20 DRAWER
AK19416	16 DRAWER
AK19909	9 DRAWER

**H-SERIES PARTS BINS**



**40 COMPARTMENT BIN.** TWO UNITS CAN BE STACKED TO FORM AN 80 COMPARTMENT UNIT. HEAVY-DUTY CONSTRUCTION. DURABLE BAKED ENAMEL FINISH. GRAY. EXTERIOR DIMENSIONS: 21" H x 35-1/4" W x 11-7/8" D. OPENING DIMENSIONS: 4" H x 4" W.

STOCK NO. MFH40

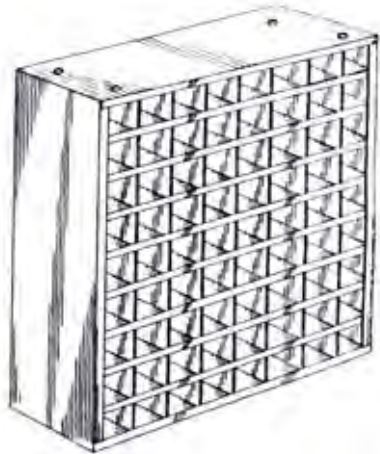

**72 COMPARTMENT BIN.** EXTERIOR DIMENSIONS: 42" H x 35-1/4" W x 11-7/8" D. OPENING DIMENSIONS: 4" H x 4" W.

STOCK NO. MFH72

**H-SERIES BASE STAND**

4" BASE LEGS. INCLUDES 16 PIECE NUT & BOLT



SET FOR ASSEMBLY. FITS MFH40 AND MFH72.

STOCK NO. MF40301

**SERVICE AS YOU WANT IT...**

**OUR ORGANIZATION IS GEARED  
TO SERVE YOU PROMPTLY  
AT ALL TIMES.  
WE SPARE NO EFFORTS IN HELPING  
OUR CUSTOMERS  
GET DELIVERY AS THEY NEED IT.  
YOU CAN DEPEND ON US.**

THE TRUCK DRIVER STOPPED AT A ROADSIDE DINER. HIS WAITRESS BROUGHT HIM A HAMBURGER, A CUP OF COFFEE, AND A PIECE OF PIE.

AS THE TRUCKER WAS ABOUT TO START EATING, THREE MEN IN LEATHER JACKETS PULLED UP ON MOTORCYCLES AND CAME INSIDE. ONE GRABBED THE MAN'S HAMBURGER, THE SECOND ONE DRANK THE COFFEE AND THE OTHER ONE TOOK HIS PIE. THE TRUCK DRIVER DIDN'T SAY A WORD. HE GOT UP, PUT ON HIS JACKET, PAID THE CASHIER AND LEFT.

ONE OF THE BIKERS SAID TO THE CASHIER, "NOT MUCH OF A MAN, IS HE?" "HE'S NOT MUCH OF A DRIVER EITHER," SHE REPLIED. "HE JUST RAN HIS TRUCK OVER THREE MOTORCYCLES."



A	—	B
ABRASIVES:		BACK-UP PADS .....100, 102, 284
BANDS.....102		BALL KEY WRENCHES .....376-377
CARTRIDGE ROLLS.....103		BALL JOINT ASSEMBLIES .....85
CUT-OFF WHEELS .....98-99		BALL PAINT MARKERS .....172
DRUMS.....102		BALL VALVES .....319, 340
FLAP DISCS.....100		BALLASTS .....246
FLAP WHEELS.....102		BANDING .....229
GRINDING WHEELS.....97-100		BANDING CUTTERS .....344
HAND PADS.....103		BANDSAW BLADES .....133-137
HAND STONES.....99		BANDSAW MACHINES .....287
MOUNTED STONES.....99		BAR CLAMPS.....393
SANDING BELTS.....101		BARREL BOLTS .....234
SANDING DISCS.....100-102		BARREL PUMPS .....331
SANDING SHEETS, ROLLS.....100-101		BARRICADES, ROAD .....215
SURFACE CONDITIONING .....103-104		BATTERIES .....240, 242-244
ABSORBENTS .....257		BATTERY CHARGERS .....256
ACETONE .....183		BATTERY CLEANER .....197
ACID BRUSHES .....184		BATTERY PROTECTORS .....196
ADHESIVE SPRAY.....175		BATTERY TERMINALS .....256
ADHESIVE, WOOD .....189		BATTERY TESTER .....256
ADJUSTABLE WRENCHES.....353, 372		BATTERY TOOLS .....381
AIR BRAKE ANTI-FREEZE.....196		BEAM CLAMPS .....339
AIR BRAKE TUBING.....314, 327		BEARING PACKER.....329
AIR FRESHENERS.....179		BEARING SPLITTER .....383
AIR HAMMER .....296		BELTS:
AIR MUFFLERS.....325		SUPPORT .....212
AIR TOOLS .....294-296		V-BELTS.....316
AIR TOOL OILS .....193		WORK .....204
AIRLINE FILTERS & REGULATORS.....313		BELT DRESSING .....174
AIRLINE FITTINGS.....311-312		BELT SANDER .....292
ALLEN WRENCHES.....375-377		BENCH GRINDER .....287-288
ALLEN SOCKETS.....354, 357-358, 362, 366, 369-370		BERNZOMATIC TORCHES .....277
ALLIGATOR CLIPS .....165		BESSEY CLAMPS .....393-394
ALLTHREAD ROD.....56, 78-79		BINS, STORAGE .....413-414
ANCHORS, MASONRY.....92-96		BIT HOLDERS .....350
ANCHOR SHACKLES.....226		BITS, POWER .....349
ANGLES:		BLADES:
IRON/BRACES.....236		BANDSAW .....133-137
SLOTTED .....235		CIRCULAR SAW .....141
ANNULAR CUTTERS/PINS .....113, 309		DEBURRING .....125
ANTI-BACTERIAL HAND SOAP.....198		HACKSAW .....140
ANTI-FREEZE .....196-197		JIGSAW .....140
ANTI-FREEZE TESTERS.....256		PORTABLE BAND .....137
ANTI-SEIZE .....174, 191		POWER HACKSAW .....140
ANTI-SPLATTER.....175		RECIPROCATING SAW .....140
APRONS.....204-205, 211, 281		UTILITY KNIFE .....149
ARBORS:		BLASTER PRODUCTS .....180, 193
HOLESAW.....139		BLEACH .....181
SHAFT.....88		BLOW GUNS .....310
TAPER.....283		BOLT CUTTERS .....233
WHEEL.....98, 102-103, 276		BOLT EXTRACTORS .....124
ASPHALT RAKES.....406		BOLTS:
ASPHALT ROLLER .....408		A325 STRUCTURAL .....14
AUTOMATIC TRANSMISSION FLUID.....197		BRASS .....53-54
AVIATION SNIPS.....344		CARRIAGE, GRADE 2.....13
AWLS.....153		CARRIAGE, GRADE 5 .....15
AXES.....384-385		CARRIAGE, STAINLESS.....47

<b>B</b>	<b>B</b>
<b>BOLTS (CONTINUED):</b>	<b>BULBS (CONTINUED):</b>
ELEVATOR .....15	ROUGH SERVICE .....246
FULL THREAD, GRADE 2, 5, 8.....3-4	SPOTLIGHT .....246
HANGER .....25	BUNGEE CORDS .....220
HEX FLANGE.....15	BURS, CARBIDE .....147-148
HEX HEAD, GRADE 2.....1-2	BUSHINGS-SHAFT .....87-88
HEX HEAD, GRADE 5 .....5-8	
HEX HEAD, GRADE 8.....9-12	<b>C</b>
HEX HEAD STAINLESS.....42-43	C-CLAMPS .....392
METRIC.....57-63	C-CLAMP PLIERS .....343, 374
METRIC, STAINLESS.....73-74	CABINETS, STORAGE .....414
NYLON, HEX HEAD.....56	CABLE, WIRE ROPE .....221
PLOW, GRADE 8.....15	CABLE CLAMPS .....222, 255
SQUARE HEAD .....15	CABLE CUTTERS .....221, 342
T-SLOT.....394	CABLE TIES, NYLON .....255
<b>BOOTS .....211</b>	CALCIUM CHLORIDE .....183
<b>BOW SAW .....407</b>	CALIPERS .....154, 158-159, 161
<b>BRAKE CLEANERS .....196</b>	CARBURETOR CLEANER .....196
<b>BRAKE FLUID .....196</b>	CARBIDE BURS .....147-148
<b>BRASS FITTINGS .....318-322, 324-327</b>	CARBIDE END MILLS .....129
<b>BRASS HAMMERS .....386</b>	CARBIDE DRILL BITS .....111, 114
<b>BRASS TAGS .....170</b>	CARPET CLEANER .....181
<b>BRAZING ROD .....280</b>	CARRIAGE BOLTS .....SEE "BOLTS"
<b>BROOM HANDLES .....272</b>	CARTON CUTTERS .....149
<b>BROOMS .....270-272</b>	CARTRIDGE ROLLS .....103
<b>BRUSH ARBOR ADAPTERS .....275</b>	CARTS, UTILITY .....259, 399
<b>BRUSHES:</b>	CASTERS .....399
ACID .....184, 273	CAULKING GUNS .....186
FENDER .....273	CAULKS & SEALANTS .....186
HAND WIRE .....184, 273	CEMENT TROWELS .....151
PAINT .....273-274	CENTER DRILL - INDEXABLE .....130
PARTS CLEANING .....273	CENTER HEAD .....160
SASH .....273	CHAIN & FITTINGS .....224-228, 231-232
SCRUB .....273	CHAIN BINDERS .....228
SNOW .....256	CHAIN (ROLLER) BREAKERS .....228
TOILET .....273	CHAIN CLAMP PLIERS .....343
TRUCK WASH .....273	CHAIN SNAPS .....231
TUBE .....276	CHAIN WRENCHES .....378
WHITEWASH .....274	CHALK .....168, 172
WIRE.....184, 273, 275-276	CHALK BOXES .....168
WIRE CUP .....275-276	CHALK LINE.....218
WIRE END .....275	CHANNELLOCK TOOLS .....341-342
WIRE SCRATCH .....184	CHEST HANDLES .....234
WIRE WHEEL .....275	CHECK VALVES .....340
<b>BUCKET HOOKS .....227</b>	CHIPPING HAMMER .....280
<b>BUCKETS .....261, 411</b>	CHIPPING HAMMER, AIR .....296
<b>BLUFF &amp; BLEND PRODUCTS .....103-104</b>	CHISEL HOLDER .....383, 389
<b>BUFFING ROLLS .....103</b>	<b>CHISELS:</b>
<b>BUFFING WHEEL .....99</b>	AIR.....296
<b>BULBS:</b>	ROTO-HAMMER .....114
AUTOMOTIVE .....246	CHISELS & SETS .....389-391
FLASHLIGHT .....240	CHOP SAW .....292
FLUORESCENT.....246-247	CIRCLE CUTTER .....153
HALOGEN .....245	CIRCUIT TESTER .....165
HIGH-PRESSURE SODIUM.....246	CIRCULAR SAW .....285
METAL HALIDE.....246	



C

C

CLAMPS:

BAR .....393  
 BESSEY.....393-394  
 "C" .....374, 392  
 CONDUIT .....339  
 HOLD DOWN .....394  
 HOSE .....314  
 PIPE FIXTURE .....392  
 SPRING .....392  
 TOGGLE .....394  
 TUBING .....255  
 WELDING .....280, 393

CLAMP ON LIGHTS .....247

CLEANERS:

DEGREASERS.....175-176, 180, 196  
 DRAIN .....183  
 FLOOR .....181  
 GENERAL PURPOSE .....179, 181, 182  
 PRESSURE WASHER .....180  
 PVC .....184  
 STAINLESS STEEL .....179, 182  
 TILE .....179, 182  
 TOILET BOWL .....179  
 WINDOW .....179

CLEANSER .....181

CLEAR ACRYLIC SPRAY .....175

CLEAVES .....226

CLEVIS PINS .....85

COAT HOOK .....235

COIL AIR HOSE .....310

COLLARS, SPLIT .....87

COLLETS, R8 .....130

COMBINED DRILLS & COUNTERSINKS .....125

CONCRETE ANCHORS .....92-95

CONDUIT CLAMPS .....339

CONES .....215, 260

CONSTRUCTION ADHESIVE .....188

CONSTRUCTION BARRELS .....215

CONTACT CEMENT .....190

CONTACT CLEANERS .....176, 192

CONTINUITY TESTER .....165

COOLANT HOSE & ACCESSORIES .....315

COOLANT UNITS .....310

COOLANTS - MACHINE .....194

COPPER TUBING .....323, 327

CORDLESS TOOLS .....290-291

CORNER BRACES .....234, 236

COTTER PINS .....47, 85

COUNTERBORE, CAP SCREW .....125

COUNTERSINKS .....125

COUPLING SHAFT .....87-88

CRACK DETECTOR .....176

CRAZY GLUE (CYANOACRYLATES) .....189

CRC LUBRICANT .....192

CREEPERS .....289

CRESCENT TYPE WRENCHES.....351-353

ECONOMY .....372

CROWBARS .....391

CROWFOOT COUPLERS .....312

CROWFOOT WRENCHES .....353

CUP DISPENSERS .....412

CUP HOOKS .....231

CUPS:

PAPER .....412

STYROFOAM .....262

CUT OFF WHEELS .....SEE "ABRASIVES"

CUTTING FLUID:

METAL .....194-195

CUTTING LUBE .....174, 191

D

DEBURRING TOOLS.....125

DEGREASERS .....175-176, 180, 196, 306

DENATURED ALCOHOL .....183

DESTACO TYPE CLAMPS .....394

DIAL INDICATORS & ACCESSORIES .....158

DIAL CALIPERS .....159

DIAMOND BLADES .....99

DIE GRINDERS .....284, 295

DIE SETTERS BAR .....391

DIE STOCK .....123

DIELECTRIC GREASE .....188, 192

DIES:

HEX .....121

PIPE .....379

ROUND .....121

DIESEL FUEL CONDITIONER .....196

DIGITAL CALIPERS .....161

DISINFECTANTS .....179, 181, 182

DISPOSABLE COVERALLS .....211

DOO-HATS .....281

DOOR PULLS .....235

DOWEL PINS .....40, 48, 66

DRAIN COCKS .....319

DRAIN CLEANERS .....183, 285, 380

DRAIN PANS .....411

DREMEL ENGRAVER .....171

DRILL ARBORS .....283

DRILL BIT EXTENSIONS .....115

DRILL BITS:

CARBIDE TIP .....111

COBALT .....110

EXTRA LENGTH .....109

JOBBER .....105

LEFT HAND .....110

MASONRY .....114

MECHANICS LENGTH .....110

**D**

DRILL BITS (CONTINUED):  
 REDUCED SHANK .....107  
 SETS .....113  
 SOLID CARBIDE .....111  
 STEP .....113  
 STUB LENGTH .....106  
 TAPER SHANK .....108  
 TITANIUM COATED .....110  
 TWIN DRILLS .....110  
 WOOD BORING .....115  
 DRILL CHUCKS & KEYS .....282-283, 308  
 DRILL DRIFTS .....113  
 DRILL GAUGES .....112,157  
 DRILL INDEXES .....112  
 DRILL PRESSES .....287  
 DRILL ROD .....80  
 DRILL SHARPENER .....112, 154  
 DRILL SLEEVES/SOCKETS .....113  
 DRILL STOP SET .....112, 155  
 DRILLS, AIR .....294  
 DRILLS, CORDLESS.....290-291  
 DRILLS, ELECTRIC .....282, 286  
 DROP CLOTHS .....268  
 DRUM:  
 CRADLES .....398  
 DEHEADERS .....331  
 DOLLIES .....398  
 FAUCETS .....331  
 LIFTERS .....226  
 PLUG WRENCH .....331  
 PUMPS .....331  
 DRY GRAPHITE .....174  
 DRY LUBE MOLY .....174  
 DRYWALL SCREWS .....SEE "SCREWS"  
 DUCK BUTTER .....185  
 DUCT TAPE .....258  
 DUPLEX SLEEVES .....221  
 DUST MASKS .....209  
 DUST MOP.....270  
 DUST PANS .....259, 270  
 DYKEM PRODUCTS .....173

**E**

E-CLIPS .....83  
 EAR PLUGS .....210  
 EASY-OUTS.....124  
 EDGE FINDER .....153  
 ELECTRODE HOLDER .....280  
 END MILLS .....126-130  
 ENGINE DEGREASER .....175  
 ENGINE PULLER .....223  
 ENGRAVER .....171  
 EPOXIES .....189-190  
 EXTENSION CORDS & ACCESSORIES .....248-250

**E**

EXTRACTORS.....124  
 EYE BOLTS .....230-232  
 E-ZOUTS.....124

**F**

FACE SHIELDS .....205  
 FANS.....400-401  
 FAUCET, HOSE .....339  
 FEELER GAUGE .....156-157  
 FENCE, ORANGE SAFETY .....215  
 FILES & ACCESSORIES .....144-146  
 FILES - THREAD REPAIR .....122  
 FILTERS, AIRLINE.....313  
 FIRE EXTINGUISHERS .....217  
 FIRST AID KITS .....206  
 FLANGE NUT - TABLE CLAMPING .....394  
 FLAGS & PENNANTS .....212, 216  
 FLAP DISCS .....SEE "ABRASIVES"  
 FLARES .....214  
 FLARING TOOLS .....380  
 FLASHERS, BARRICADE .....216  
 FLASHLIGHTS .....240-244  
 FLAT GROUND STOCK .....80  
 FLAT WASHERS .....SEE "WASHERS"  
 FLEXANGLE .....235  
 FLINTS .....277  
 FLOOR CLEANERS .....181  
 FLOOR COATINGS .....181  
 FLOOR DRY .....257  
 FLOOR PATCH COMPOUNDS .....190  
 FLOOR SCRAPER .....405  
 FLUX .....184  
 FLUX CHIPPER .....296  
 FOAM SEALANT .....186  
 FOLD-UP KEY SETS .....375, 377  
 FOOT GUARDS .....211  
 FORM-A-GASKET .....188  
 FORM STRIPPING BAR .....391  
 FUEL STABILIZER .....197  
 FUNNELS .....411  
 FURNACE FILTERS .....402  
 FURNITURE POLISH .....181  
 FUSES, AUTOMOTIVE .....254

**G**

GALVANIZING SPRAY .....175  
 GARDEN HOSE.....264  
 GARDEN HOSE FITTINGS .....321  
 GAS CANS .....410  
 GAS LEAK DETECTOR.....185  
 GAS LINE ANTIFREEZE .....196  
 GAS VALVES .....340  
 GASKET MATERIAL .....187-188  
 GASKET REMOVER .....175

**CALL US FOR ALL YOUR NEEDS**  
**855-785-TOOL**

**G**

GASKET SCRAPER .....382  
 GASKET SEALANTS .....187-188  
 GATE VALVES .....340  
 GAUGES:  
     DRILL .....112, 157  
     PRESSURE .....317  
     RADIUS .....157  
     SHEET METAL .....157  
     TELESCOPING .....161  
     THICKNESS .....156-158  
     THREAD .....157  
     TIRE .....310  
     WIRE .....157  
 GEAR LUBE .....191  
 GEAR PULLERS .....383  
 GFCI CORDS .....249  
 GLOVES .....200-202, 281  
 GLUE GUN .....189  
 GLUES .....189  
 GOGGLES .....207  
 GORILLA GLUE .....189  
 GREASE .....188, 191, 192, 328  
 GREASE FITTINGS .....330  
 GREASE FITTING REMOVER .....329, 382  
 GREASE GUNS & ACCESSORIES .....328-329  
 GRINDERS, ANGLE .....284-286, 292  
 GRINDERS, BENCH .....287-288  
 GRINDING WHEELS .....SEE "ABRASIVES"  
 GROMMETS .....253  
 GROUND CLAMPS .....280

**H**

HACKSAW BLADES .....140  
 HACKSAWS .....140  
 HAIRPIN COTTERS .....85  
 HALOGEN WORKLIGHTS .....245  
 HAMMERS .....384-386  
     ECONOMY .....374  
 HAMMERS, WELDING CHIPPING .....280  
 HAMMER DRILLS .....282, 285-286, 290-291  
 HAMMER HOLDER .....204  
 HAND CLEANERS / DISPENSERS .....188, 198-199  
 HANDPADS .....103  
 HAND TRUCKS .....398-399  
 HANDLES:  
     CHEST & DRAWER .....234-235  
     FILE .....144, 146  
     REPLACEMENT TOOL .....387-388  
 HANGER STRAP .....229  
 HARDHAT LIGHT .....243  
 HARDHAT LINERS .....210  
 HARDHATS .....205

**H**

HARNESS, BODY .....212  
 HASPS .....234  
 HEARING PROTECTION .....210  
 HEAT ABSORBING PASTE .....184  
 HEAT CABLE .....279  
 HEAT GUNS .....279  
 HEAT SHRINK TUBING .....253  
 HEATER HOSE .....314  
 HEATERS .....402  
 HEDGE TRIMMER .....407  
 HELICOILS .....90  
 HEX KEYS & SETS .....162, 375-377  
 HINGES .....234-235  
 HI-SPOT BLUE .....173  
 HITCH PINS .....86  
 HOES .....406, 408  
 HOLE CUTTERS .....113, 309  
 HOLE PUNCHERS .....171  
 HOLESAWS & ACCESSORIES .....138-139  
 HOISTS .....223  
 HONES, CYLINDER .....382  
 HOOKS:  
     CHAIN / SNAP .....224-228, 231-232  
     STORAGE .....233  
 HOSE:  
     AIRLINE .....314  
     COIL .....310  
     DISCHARGE .....264  
     PNEUMATIC .....305  
     WATER .....264  
     WELDING .....280  
 HOSE BARBS .....305, 318  
 HOSE CLAMPS .....314  
 HOSE FAUCET .....339  
 HOSE HANGER .....264  
 HOSE NOZZLE .....264  
 HOSE REELS .....314  
 HYDRAULIC JACKS .....289  
 HYDRAULIC OIL .....197  
 HYDRAULIC SEALANT .....185

**I**

ICE MELTERS .....183, 197  
 IMPACT DRIVER .....348  
 IMPACT WRENCH, AIR .....294  
 IMPACT WRENCH, CORDLESS .....290-291  
 IMPACT WRENCH, ELECTRIC .....286  
 INSECT REPELLENT .....175  
 INSERTS, CARBIDE & CERAMIC .....131-132  
 INSULATING VARNISH .....175  
 INVISIBLE GLOVE .....199

**J**

JACKS, HYDRAULIC .....289  
 JANITORIAL CHEMICALS .....179-182  
 JEWELER'S SCREWDRIVERS .....348  
 JIGSAW BLADES .....140  
 JIGSAWS .....284  
 JUMPER CABLES .....256

**K**

KEY CADDY .....168  
 KEY RINGS .....168, 170  
 KEYSTOCK .....81  
 KNEE PADS .....204  
 KNIVES .....149-150  
 KNOCKOUT PUNCHES .....380

**L**

LACQUER THINNER .....183  
 LADDERS .....396-397  
 LAG BOLTS .....SEE "SCREWS"  
 LANDSCAPE RAKES .....406  
 LANYARDS .....212  
 LAYOUT FLUID .....173, 177  
 LEAK DETECTOR .....185  
 LEAK REPAIR PRODUCTS .....189-190  
 LENS CLEANING PRODUCTS .....205  
 LEVELS .....161, 168-169  
 LIFTER'S BELTS .....212  
 LIFTING CLAMPS .....226  
 LIGHTBULBS .....SEE "BULBS"  
 LIME REMOVER .....180, 182, 183  
 LINE REELS .....168  
 LINERS, WINTER .....210  
 LIGHTS:  
     12V SPOTLIGHT .....247  
     BARRICADE .....216  
     HALOGEN.....245  
     PORTABLE WORK .....245-248  
     TEMPORARY .....245  
     WORKBENCH .....247  
 LOAD BINDERS .....228  
 LOCKOUTS & TAGS .....239  
 LOCKS .....237-239  
 LOCKWIRE .....156  
 LOCTITE .....SEE "THREAD SEALANTS"  
 LOPPING SHEARS .....408  
 LPS PRODUCTS .....192  
 LUBRICANTS.....191-195  
 LUMBER CRAYONS .....172  
 LUTE RAKES .....406  
 LYSOL .....181

**M**

MACHINE SCREWS .....SEE "SCREWS"  
 MACHINERY BUSHINGS .....87  
 MAG DRILL .....307-308  
 MAG DRILL CUTTERS .....113, 309  
 MAGIC MARKERS .....172  
 MAGNETS:  
     PICKUP TOOL / LIFTING .....154, 226, 381  
     POT .....154  
 MAGNETIC BASE .....158  
 MAGNIFYING GLASSES .....154, 247  
 MARKERS .....172-173  
 MARKING PAINTS .....177  
 MARKING WAND .....177  
 MASONRY ANCHORS .....92-96  
 MASONRY DRILL BITS .....114  
 MATTOCKS .....391  
 MEASURING WHEELS .....169  
 MECHANIC'S STETHOSCOPE .....381  
 MECHANICS'S WIRE .....229  
 MENDING BRACES .....234-236  
 METATARSAL GUARDS .....211  
 METERS .....163-165  
 METRIC FASTENERS .....57-77  
 MICROMETERS .....159-160  
 MIRRORS, INSPECTION .....381  
 MIST COOLANT UNIT .....310  
 MOLD RELEASE .....176  
 MOP BUCKET .....261  
 MOPS .....261, 270  
 MORTAR HOES .....406, 408  
 MOTOR ARBORS .....88  
 MOTOR COUPLINGS .....88  
 MOUNTED POINTS .....99  
 MURIATIC ACID .....183  
 MURPHY'S OIL SOAP .....181  
 MUSIC WIRE .....156

**N**

NAIL PULLERS .....391  
 NAILS/STAPLES.....302-304  
 NAILERS/STAPLERS.....296-301  
 NAILERS/STAPLERS ACCESSORIES.....305-306  
 NORD-LOCK WASHERS.....18  
 NUT CRACKER .....382  
 NUT DRIVER .....348  
 NUT DRIVER SET ECONOMY .....374  
 NUTS:  
     A325.....21  
     BRASS.....54-55  
     CAP (ACORN) .....20, 41, 55  
     HEX .....19-22, 41, 54-56  
     LOCK .....21-22, 41, 54  
     METRIC .....68  
     METRIC, STAINLESS .....73

**N**

NUTS (CONTINUED):  
 MISCELLANEOUS .....21-23  
 NYLON .....56  
 ROD COUPLING .....23, 41  
 SQUARE .....22  
 STAINLESS .....41  
 T-SLOT .....394  
 TEE PRONG .....22  
 WING .....22, 41, 55  
 NUT SETTERS .....350  
 NUTSERTS .....91  
 NYLON AIR BRAKE FITTINGS .....327  
 NYLON FASTENERS .....56

**O**

OETIKER CLAMPS .....314  
 OIL DISPENSING CANS .....410  
 OIL DRI .....257  
 OIL FILTER WRENCHES .....382  
 O-RINGS .....83  
 OILS:  
 3-IN-1 .....193  
 AIR TOOL .....193  
 CUTTING .....193-195, 379  
 HYDRAULIC .....197  
 JACK .....289  
 LPS .....192  
 MARVEL MYSTERY OIL .....196  
 MOTOR .....196  
 PNEUMATIC.....305  
 TRI-FLOW .....193  
 WD-40 .....193  
 WATER SOLUBLE .....194-195  
 OILERS, PUMP .....410  
 OPEN GEAR/CHAIN LUBE .....174  
 OVERSIZE/WIDE LOAD BANNER .....216

**P**

PAINT .....177-178  
 PAINT CAN, EMPTY.....178  
 PAINT MIXER.....178  
 PAINT ROLLERS/TRAYS .....274  
 PAINT REMOVER .....175  
 PAINT THINNER .....183  
 PAINTSTICK MARKERS .....172  
 PALLET JACK .....289  
 PALLET PULLER .....221  
 PAPER CUPS .....412  
 PAPER TOWELS /WIPERS.....262-263  
 PARTS WASHER SOLVENT .....183  
 PEDESTAL, GRINDER .....287-288  
 PEGBOARD HOOKS .....233  
 PENCIL, CARPENTER .....172  
 PENETRANTS .....174, 191-193

**P**

PENNANTS .....212  
 PERMATEx PRODUCTS .....185, 188  
 PHONE .....105  
 PIANO HINGE .....235  
 PICKINGTOOL.....162,347,382  
 PICKS .....391  
 PICK-UP TOOLS .....154, 381  
 PIN VISE .....154, 162, 283  
 PINESOL .....181  
 PINS:  
 CLEVIS .....85  
 COTTER .....47, 85  
 DOWEL .....40, 48, 66  
 HITCH .....86  
 POWDER ACTUATED .....96  
 SPRING.....47,71-72,86  
 TAPER .....87  
 PIPE CLAMP FIXTURE .....392  
 PIPE CLAMPS .....339  
 PIPE CUTTERS .....378  
 PIPE FITTINGS:  
 BRASS .....320-321  
 STAINLESS STEEL .....337-338  
 STEEL .....332-337  
 PIPE HANGERS .....339  
 PIPE JOINT COMPOUND .....185  
 PIPE REAMERS .....378  
 PIPE THREADERS .....378-379  
 PIPE VISE .....379  
 PIPE WRENCHES .....378  
 ECONOMY .....372  
 PITCHFORKS .....407  
 PLATE LIFTING CLAMPS .....226  
 PLATES, STYROFOAM .....262  
 PLEDGE .....181  
 PLIERS .....314, 341-345  
 ECONOMY .....374  
 PLIERS, WIRE STRIPPING .....254, 342  
 PLUMB BOBS .....153  
 POLYFILM .....268  
 POP RIVETS & TOOLS .....82  
 PORTABAND SAW .....285  
 POSTHOLE DIGGERS .....407  
 POWDER ACTUATED TOOLS & ACCESSORIES .....96  
 POWER BITS & HOLDERS .....349-350  
 POWER STRIP.....250  
 POWER TOOLS:  
 AIR .....294-296  
 CORDLESS .....290-291  
 ELECTRIC .....282, 284-286, 292  
 PNEUMATIC.....297-302  
 PROPANE TORCHES .....277  
 PROTRACTORS .....154-155, 160-161  
 PRUNING TOOLS .....408  
 PRUSSIAN BLUE .....173

**P**

PRY BARS .....391  
 PULLEYS, ROPE & CABLE .....219  
 PUMPS .....265-266  
 PUNCH & CHISEL HOLDER .....383  
 PUNCHES:  
   CENTER .....153, 389  
   HOLE .....171  
   LINING .....389  
   PIN.....153, 389  
   TRANSFER .....171  
   PUNCHES & SETS .....389-390  
 PUSH-IN FITTINGS .....326  
 PUTTY KNIVES .....151  
 PVC CEMENT .....184

**R**

RADIATOR FILLER .....411  
 RADIATOR SEALANT .....197  
 RAGS .....262  
 RAINSUITS .....210  
 RAKES .....406  
 RATCHET SLINGS .....220  
 RATCHETING BOX WRENCHES .....353  
 RATCHETS, AIR .....296  
 RATCHETS & ACCESSORIES.355,360,364-365,367-368  
 RATCHETS, ECONOMY .....373  
 RAWHIDE HAMMERS .....384, 386  
 RAZOR BLADES .....149  
 REAMER, PIPE .....378  
 REAMERS .....125  
 RECIPROCATING BLADES .....140  
 RECTOR SEAL .....185  
 REEL LIGHTS .....248  
 REFERENCE BOOK .....381  
 REFERENCE GAUGE .....154  
 REFLECTORS .....213  
 REGULATORS, AIRLINE.....313  
 RESPIRATORS .....209  
 RETHREAD DIES .....121, 122  
 RIVETS & TOOLS .....82  
 ROAD SAFETY .....215-216  
 ROCK SALT .....183  
 ROLL PINS .....47, 71-72, 86  
 ROLL TOWEL DISPENSER .....262  
 ROLLER, PAVING .....408  
 ROLLER CHAIN .....228  
 ROPE .....218  
 ROUND BAR .....81  
 ROUTER BITS .....142-143  
 RUBBERDRUM.....102  
 RUBBER REPAIR PRODUCTS .....189  
 RULES .....155, 166-169  
 RUST CONVERTER .....178  
 RUST PREVENTER .....174

**S**

S-HOOKS .....170, 224, 233  
 SAFETY EQUIPMENT .....205-217  
 SAFETY FENCE .....215  
 SAFETY GLASSES .....207-208  
 SAFETY HARNESS & ACCESSORIES .....212  
 SALT, ROCK.....183  
 SANDERS, AIR .....295  
 SANDING BANDS .....SEE "ABRASIVES"  
 SANDING DISCS .....SEE "ABRASIVES"  
 SANDING PAPER .....SEE "ABRASIVES"  
 SANDINGBELTS .....101  
 SAW BLADES - CIRCULAR .....141  
 SAWS:  
   BOW .....407  
   CIRCULAR .....285  
   CHOP .....292  
   FOLDING .....140  
   HACK .....140  
   HAND CROSSCUT .....140  
   METAL CUTTING .....292  
   PVC .....140  
   PORTABAND .....285  
 SAWZALL BLADES .....140  
 SAWZALL TOOL .....285  
 SCALER, AIR .....296  
 SCISSORS .....152  
 SCRAPERS:  
   FLOOR .....405  
   GASKET .....382  
   HAND .....151  
   RAZOR BLADE .....149  
 SCREW EXTRACTOR & SETS.....124  
 SCREW GUN .....286  
 SCREW PITCH GAUGES .....157  
 SCREW STARTERS .....348  
 SCREWDRIVERS .....162, 346-348, 350  
   ECONOMY .....374  
 SCREWDRIVER SOCKETS .....358, 365  
 SCREWS:  
   CABINET .....24  
   DECK/DRYWALL .....24  
   DRILL POINT .....26  
   DRIVE .....24, 82  
   FLOORBOARD .....25  
   LAG .....24, 46  
   LICENSE PLATE .....24  
   MACHINE .....28-31, 49-52, 56  
   METRIC, MACHINE .....70  
   METRIC, SOCKET .....64-66  
   METRIC, STAINLESS .....74-77  
   SHEET METAL .....26-28, 48-49  
   SOCKET HEAD .....32-34, 44-46  
   SOCKET BUTTON HEAD .....35, 45, 65, 75-76  
   SOCKET FLAT HEAD .....36, 45, 64-65, 75  
   SOCKET LOW HEAD .....37, 66

**CALL US FOR ALL YOUR NEEDS**  
**855-785-TOOL**

**S**

SCREWS (CONTINUED):  
 SOCKET SET .....37-39, 67, 76—  
 SOCKET SHOULDER.....39-40  
 SQUARE HEAD SET .....39  
 TAMPERPROOF .....28  
 THREAD CUTTING .....24  
 THUMB .....24  
 WOOD .....24-26, 55  
 SCRIBERS .....153, 162  
 SEALANTS .....186-190  
 SHAFT:  
     ARBORS.....88  
     BUSHINGS .....87-88  
     COLLARS .....87  
     COUPLINGS .....88  
     KEY.....88  
 SHEET METAL SCREW .....SEE "SCREWS"  
 SHEET METAL VISE GRIPS .....343  
 SHELF BINS .....413  
 SHELLAC .....178  
 SHELVING .....235  
 SHIM STOCK .....156  
 SHOP ROLLS .....101  
 SHOP VACS .....269  
 SHOVELS .....403-405, 408  
 SHRINK WRAP .....268  
 SIGNS .....213-216, 260  
 SILICONE SEALANTS .....186-188  
 SILICONE SPRAY .....176  
 SIMPLE GREEN.....182  
 SLEDGE HAMMERS .....385  
 SLIDING ARM CLAMPS .....393  
 SLINGS .....220-221  
 SMOKERS RECEPTACLE.....259  
 SNAP RING PLIERS .....345  
 SNAP RINGS & KITS .....84  
 SNAPS .....231-232  
 SNOW BRUSHES/SCRAPERS .....256  
 SNOW SHOVELS .....405  
 SOAP, HAND.....188, 198-199  
     LAVA BAR.....198  
 SOAPSTONE.....172  
 SOCKET CAP SCREWS .....SEE "SCREWS"  
 SOCKET HOLDERS .....371  
 SOCKET SET SCREWS .....SEE "SCREWS"  
 SOCKETS & SETS .....354-371  
     ECONOMY .....373  
 SOLDER PRODUCTS .....184  
 SOLDERING TOOLS .....278  
 SPANNER WRENCHES .....100, 284, 371  
 SPONGES .....260  
 SPRAY BOTTLES .....260  
 SPRAY GUN, HYDRO BLAST .....310

**S**

SPRAY PRODUCTS:  
 ADHESIVE .....175  
 AIR FRESHENERS .....179  
 ANTI-SEIZE .....174  
 ANTI-SPLATTER .....175  
 BATHROOM DISINFECTANT.....179, 181  
 BELT DRESSING .....174  
 CARPET CLEANER .....181  
 CHAIN LUBE .....174  
 CLEAR ACRYLIC .....175  
 CONTACT CLEANER .....176  
 CRACK DETECTOR .....176  
 CUTTING OIL .....174  
 DEGREASER.....175, 180, 196  
 DE-ICER .....197  
 DRY GRAPHITE .....174  
 DRY MOLY .....174  
 GALVANIZE .....175  
 GEAR/ROPE LUBE .....174  
 INSECTICIDE .....175  
 LAYOUT FLUID .....173, 177  
 LUBRICANTS .....174, 191-193  
 MAGNUM GREEN.....180  
 MOLD RELEASE .....176  
 MOP & CLOTH TREATMENT .....181  
 PAINT .....177-178  
 PENETRANTS .....174, 192-193  
 PAINT/GASKET REMOVER .....175  
 RUST PREVENTATIVE .....174, 192  
 SILICONE .....176  
 STENCIL INKS .....177  
 STRIPING PAINT .....177  
 TEFLON LUBE .....174  
 UNDERCOAT .....187  
 VARNISH .....175  
 WHITE GREASE .....174, 191  
 WINDOW CLEANER .....179  
 SPRAYERS, TANK .....267  
 SPREADERS .....183, 408  
 SPRING CLAMPS .....392  
 SPRING PINS .....47, 71-72, 86  
 SPRINGS .....89  
 SPUD BARS .....391  
 SQUARES .....155, 160-161, 169  
 SQUEEGEES .....260  
 STAINLESS STEEL FASTENERS .....41-52, 73-77  
 STAIR GAUGES .....154  
 STAMPS .....170  
 STAPLES/NAILS.....302-304  
 STAPLERS / NAILERS .....296-301  
 STAPLERS/NAILERS ACCESSORIES.....305-306  
 STARTING FLUID .....196  
 STEEL WOOL .....103  
 STENCIL INK - AEROSOL .....177

**S**

STENCILS .....170  
 STEP DRILLS .....113  
 STETHOSCOPE, MECHANICS .....381  
 STODDARD SOLVENT .....183  
 STONES, ABRASIVE .....99, 100  
 STOP PADDLES .....215  
 STORAGE BINS .....413-414  
 STORAGE HOOKS.....233  
 STP OIL ADDITIVE .....196  
 STRAP WRENCHES .....378  
 STRAPPING .....229  
 STRETCH WRAP .....268  
 STRIKERS .....277, 280  
 STRIKING BOX WRENCHES .....353  
 STRIP DOORS .....402  
 STRIPING PAINTS & MACHINES .....177  
 STROBE LIGHT .....216  
 STRUCTURAL ADHESIVES .....189  
 STRUT & FITTINGS .....339  
 STUDS, THREADED .....81  
 SUCTION GUN .....328  
 SUMP PUMPS .....265-266  
 SUPERKNIFE .....149  
 SUPPORT BELTS .....212  
 SURFACE CONDITIONING PRODUCTS .....103-104  
 SUSPENDERS .....204  
 SWAGER TOOL, WIRE ROPE .....221  
 SWEATBANDS .....210  
 SWEEPING COMPOUND .....257  
 SWIVELS, AIRLINE .....310

**T**

T-BEVEL, SLIDING .....154  
 T-SLOT NUTS, BOLTS .....394  
 TAGS .....170  
 TAMPERPROOF SCREWS .....28  
 TAMPERPROOF TOOLS .....349-350  
 TAMPERS .....407  
 TAP & DIE SETS .....117, 120  
 TAP EXTENSIONS .....117, 123  
 TAP EXTRACTORS .....123  
 TAP WRENCHES .....123  
 TAPCONS.....96  
 TAPE:  
 ANTI-SKID .....212  
 CARTON SEALING .....258  
 CAUTION .....213  
 DISPENSER .....258  
 DOUBLE-FACED .....258  
 DUCT .....258  
 ELECTRICAL .....253  
 FOAM .....258  
 FILAMENT .....258  
 GAFFERS .....258

**T**

TAPE (CONTINUED):  
 HAZARD STRIPE .....212  
 MASKING .....258  
 REFLECTIVE.....212  
 RULES .....166-167  
 SURVEYORS .....213  
 TEFLON .....185  
 TAPFREE PRODUCTS .....195  
 TAPER PINS .....87  
 TAPS .....116-120  
 TARP STRAPS .....220  
 TARPS, POLY .....268  
 TEFLON LUBE .....174  
 TEFLON PIPE SEALANT .....185  
 TEFLON TAPE .....185  
 TEMPERATURE STICKS .....172  
 TEST EQUIPMENT .....163-165  
 THERMOMETERS.....163  
 THIMBLES, WIRE ROPE .....222  
 THINNER .....173, 183  
 THREAD CUTTING OIL, RIDGID .....193, 379  
 THREAD REPAIR INSERTS .....90-91  
 THREAD REPAIR TOOLS .....122  
 THREAD SEALANTS:  
 LOCKING .....186, 188  
 PIPE .....185  
 THREADED ROD .....56, 78-79  
 TIE DOWNS .....220  
 TIE MOUNTS .....255  
 TIE WIRE .....229  
 TIN CANS, EMPTY.....178, 411  
 TIN SNIPS .....344  
 TIP CLEANER .....277  
 TIRE GAUGES & CHUCKS .....310  
 TIRE SEALANTS .....197  
 TOGGLE CLAMPS .....394  
 TOILET BOWL CLEANERS .....179  
 TOILET PLUNGER .....261  
 TOILET TISSUE .....262  
 TOOL BALANCER.....308  
 TOOL BITS .....131  
 TOOL BOXES .....413  
 TOOL DIP .....178  
 TOOL POUCHES .....203-204  
 TORCHES:  
 BUTANE .....278  
 PROPANE .....277  
 TORQUE WRENCHES .....371  
 TORX:  
 FOLD-UP KEY SET .....375  
 INSERT BIT .....349  
 SCREWDRIVER SET .....347  
 SECURITY WRENCH .....350  
 SOCKET SET .....348



**CALL US FOR ALL YOUR NEEDS**  
**855-785-TOOL**

**T**

TOTETRAY .....259  
 TRAMMELPOINTS.....153  
 TRANSFERPUNCHES.....171  
 TRASH BAGS .....268  
 TRASH CANS .....259  
 TREE TRIMMER .....408  
 TRIANGLE WARNING KIT .....215  
 TRI-FLOW LUBRICANT .....193  
 TROUBLE LIGHTS .....247-248  
 TROWELS .....151  
 TUBE BRUSHES .....276  
 TUBING BENDERS .....380  
 TUBING CLAMPS .....255  
 TUBING CUTTERS & WHEELS .....379  
 TUBING:  
     AIR BRAKE .....327  
     COPPER .....323, 327  
     NYLON.....323  
     POLY .....323  
     VINYL .....323  
 TURNBUCKLES .....222  
 TWINE .....218

**U**

U-BOLTS .....233  
 UNDERCOAT SPRAY .....187  
 UNIBITS .....113  
 UNISTRUT & FITTINGS .....339  
 UNTHREADED ROD .....81  
 URINAL BLOCKS .....262  
 UTILITY KNIVES/BLADES .....149-150

**V**

V-BELTS.....316  
 VACUUMS .....269  
 VARNISH .....175  
 VALVES .....310, 319, 340  
 VELCRO .....255  
 VESTS, SAFETY .....216  
 VISE GRIP TOOLS .....343  
 VISES:  
     BENCH .....395  
     DRILL PRESS .....287, 395  
     PIN .....283  
     PIPE .....379  
 VISQUEEN .....268  
 VOLTAGE TESTER .....165

**W**

WARNING TRIANGLE KIT .....215  
 WASHERS:  
     BELLEVILLE .....18  
     BEVEL (SQUARE) .....18  
     BRASS .....54  
     COPPER .....54  
     EXTRA THICK .....16  
     FENDER .....16, 42  
     FINISHING .....16, 42, 54  
     FLAT .....16, 42, 54, 69  
     LOCK .....17, 42, 54, 69  
     METRIC .....69  
     METRIC, STAINLESS .....73  
     NORD-LOCK.....18  
     NYLON .....56  
     SEALING .....26, 42  
     STAINLESS .....42  
 WASP & HORNET SPRAY .....175  
 WASTE BASKETS .....259  
 WATER COOLERS & JUGS .....412  
 WATER SOLUBLE .....194-195  
 WAY LUBRICANT.....194  
 WAX STICK (EDGE LUBE) .....191  
 WD-40 PRODUCTS .....191, 193  
 WEATHERSTRIP ADHESIVE .....187  
 WEDGES, STEEL .....385  
 WEED TRIMMER .....407  
 WELDING CLAMPS .....280, 393  
 WELDING SUPPLIES:  
     CABLE .....280  
     CLOTHING .....205, 281  
     CYLINDER TRUCKS .....398  
     GLOVES .....201, 280  
     GOGGLES .....280  
     HAMMERS .....280  
     HOSE .....280  
     HELMETS .....207, 280  
     LENSES .....207, 280  
     MAGNETIC SQUARES .....280, 394  
     ROD .....280  
 "WET FLOOR" SIGNS .....260  
 WHEEL CHOCK .....216  
 WHEEL DRESSER .....98  
 WHEEL GUARDS .....284-285  
 WHEELBARROWS .....409  
 WHISK BROOMS.....270  
 WHITE GREASE .....174, 191  
 WIGGY TESTER .....165  
 WINDOW CLEANERS .....179  
 WINDSHIELD WASHER FLUID .....197  
 WINTER LINERS .....210

**W**

WIRE:

- AUTO PRIMARY .....254—
- ELECTRICAL .....250
- LOCK .....156
- MECHANICS .....229
- PIANO .....156
- TIE .....229

WIRE BRUSHES, HAND .....184, 273

WIRE END BRUSHES .....275

WIRE LOOM .....253

WIRE MARKERS .....253

WIRE NUTS .....251

WIRE ROPE / SLINGS.....221

WIRE STRIPPERS / CRIMPERS .....254

WIRE TERMINAL PLIERS .....254

WIRE TERMINALS .....251-252

WIRE WHEELS .....275-276

WOODRUFF KEYS .....88

WOOD SCREWS .....”SEE SCREWS”

WRENCHES:

- OIL FILTER .....256, 382
- TAP .....123
- WRENCHES & SETS .....351-353
- ECONOMY .....372

WRINGERS .....261

**X**

XYLENE .....183

**Y**

YOKE ENDS .....85

**Z**

ZOOM SPOUT OILER .....192

**TRADE PRACTICES**

- ORDERS:** PLEASE SPECIFY COMPLETE INFORMATION ON QUANTITY, SIZE, PART NUMBERS, DESCRIPTIONS, SHIPPING INFORMATION, AND REQUIRED DELIVERY DATES.
- PRICES:** WE HAVE OMITTED PRICES FROM THIS CATALOG. CURRENT PRICES WILL BE FURNISHED UPON REQUEST.
- QUOTATIONS:** QUOTATIONS ARE MADE FOR PROMPT ACCEPTANCE AND SUBJECT TO CHANGE WITHOUT NOTICE UNLESS A SPECIFIED DATE IS GIVEN.
- TAXES:** SALES AND USE TAX WILL BE ADDED TO THE INVOICE UNLESS WE HAVE ON FILE THE PROPER TAX EXEMPTION CERTIFICATE.
- CANCELLATIONS:** ORDERS FOR SPECIAL OR NON-STANDARD MERCHANDISE CANNOT BE CANCELLED WITHOUT THE PERMISSION OF THE MANUFACTURER. CANCELLATION CHARGES MAY BE ASSESSED TO STANDARD TRADE PRACTICE.

**RESPONSIBILITY**

IT IS OUR POLICY TO REPRESENT RELIABLE MANUFACTURERS. THE GUARANTEES AGAINST DEFECTIVE MATERIALS PROVIDED BY THESE MANUFACTURERS WILL PREVAIL. WE LIMIT OUR LIABILITY TO THESE GUARANTEES. WE ASSUME NO LIABILITY FOR DAMAGE TO PERSON OR PROPERTY CAUSED BY MERCHANDISE BOUGHT FROM OR THROUGH US. STATISTICAL INFORMATION CONTAINED IN THIS CATALOG IS DERIVED FROM MANUFACTURERS' DATA AND PRINTED SOLELY FOR OUR CUSTOMERS' CONVENIENCE. SELECTION OF ITEMS FOR A PARTICULAR USE IS AT THE SOLE DISCRETION AND RISK OF THE PURCHASER.

**TO HAVE AN OPEN ACCOUNT**

WE REQUIRE THAT ALL CUSTOMERS MUST SUBMIT AT LEAST THREE (3) REFERENCES, PLUS A BANK REFERENCE. THERE IS A \$15.00 SERVICE CHARGE FOR ALL NSF CHECKS.

- ◆ OUR TERMS: NET 30 DAYS
- ◆ ANY PAST DUE INVOICES OR RETURNED CHECKS MAY CAUSE YOUR OPEN ACCOUNT TO BE CHANGED TO C.O.D.
- ◆ IF ANY ACCOUNT IS PAST 30 DAYS PAST DUE, NO SHIPMENTS WILL BE MADE, AND ALL FUTURE PURCHASES MAY BE C.O.D.
- ◆ WE ACCEPT MASTER CARD AND VISA CREDIT CARDS.
- ◆ THE MINIMUM CHARGE FOR A CREDIT CARD TRANSACTION IS \$10.00.

